

Comparison of Cyclone Design Methods for Removal of Fine Particles from Plasma Generated Syngas

Mareli Hattingh, I. Jaco Van der Walt, Frans B. Waanders

Abstract—A waste-to-energy plasma system was designed by Necsa for commercial use to create electricity from unsorted municipal waste. Fly ash particles must be removed from the syngas stream at operating temperatures of 1000 °C and recycled back into the reactor for complete combustion. A 2D2D high efficiency cyclone separator was chosen for this purpose. During this study, two cyclone design methods were explored: The Classic Empirical Method (smaller cyclone) and the Flow Characteristics Method (larger cyclone). These designs were optimized with regard to efficiency, so as to remove at minimum 90% of the fly ash particles of average size 10 µm by 50 µm. Wood was used as feed source at a concentration of 20 g/m³ syngas. The two designs were then compared at room temperature, using Perspex test units and three feed gases of different densities, namely nitrogen, helium and air. System conditions were imitated by adapting the gas feed velocity and particle load for each gas respectively. Helium, the least dense of the three gases, would simulate higher temperatures, whereas air, the densest gas, simulates a lower temperature. The average cyclone efficiencies ranged between 94.96% and 98.37%, reaching up to 99.89% in individual runs. The lowest efficiency attained was 94.00%. Furthermore, the design of the smaller cyclone proved to be more robust, while the larger cyclone demonstrated a stronger correlation between its separation efficiency and the feed temperatures. The larger cyclone can be assumed to achieve slightly higher efficiencies at elevated temperatures. However, both design methods led to good designs. At room temperature, the difference in efficiency between the two cyclones was almost negligible. At higher temperatures, however, these general tendencies are expected to be amplified so that the difference between the two design methods will become more obvious. Though the design specifications were met for both designs, the smaller cyclone is recommended as default particle separator for the plasma system due to its robust nature.

Keywords—Cyclone, design, plasma, renewable energy, solid separation, waste processing.

I. INTRODUCTION

NECSA'S PlasWEn project uses a plasma gasification waste-to-energy system, designed to gasify carbonaceous waste, thereby generating syngas with the capability to create fuel, electricity and wax. These small, portable plants can fit onto the back of a trailer and could possibly be commercially sold to private owners across South Africa. The primary aim of this project is waste minimization with minimal pollution generation.

The thermal plasma gasifier forms the heart of this plant. Here syngas is created from an assortment of waste types,

M. Hattingh and F. B. Waanders are with the Department of Chemical and Mineral Engineering of the North West University, Potchefstroom, 2520 South Africa. (e-mail: mh910416@gmail.com, frans.waanders@nwu.ac.za).

I. J. van der Walt is with the Department of Research and Development at Necsa, Pelindaba, 0240, South Africa (e-mail: jaco.vanderwalt@necsa.co.za).

such as municipal solid waste, wood chips, nut shells or various other types. Usually, one of the greatest advantages of plasma gasification is its ability to approach complete conversion of carbon into CO. However, this is limited by the degree of mixing and the residence time of the fuel in the reactor. Under normal operating conditions, some ash and unburned solids are still present in the exhaust gas.

The current reactor design allows for heavier dust or char to collect at the bottom. These solid pieces of carbon can be removed from the reactor base. However, the problem lies in removing fly ash from the syngas. The ideal would be for all the fly ash to be gasified inside the plasma reactor. Thus the aim of this study is to design a piece of equipment that can remove the fly ash from the syngas stream at process temperature (1000 °C) and recycle the particles back into the reactor for complete gasification. This concept of "complete conversion" can be better understood by realising how plasma gasification differs from conventional gasification methods. When plasma is used, the plasma itself acts as primary energy source, so that most of the energy needed for the gasification process is provided from an external source. During conventional combustion, on the other hand, energy is taken from the material's calorific value, lowering the energy value of the resulting syngas [2]. Thus plasma gasification is a much more efficient process than normal gasification or incineration. Plasma gasification decomposes virtually all of the fuel, creating a cleaner syngas at higher temperatures than conventional methods [4]. Tar and char will usually not be formed, though soot is present in the syngas in equilibrium amounts during wood gasification. Thus, it is possible to reach reaction equilibrium in the plasma gasifier if the residence time and degree of mixing are adequate. Using a recycling system could solve both these problems. With this in mind, a high efficiency cyclone separator was chosen as the particle removal system.

Except for its ease of operation, the cyclone is cheap to maintain and can handle high temperatures (depending on the choice of material), which makes it ideal for this application. For design considerations, the reactor feed material was chosen as wood chips.

II. DESIGN

A. The Cyclone Separator

The basic working of the cyclone separator is quite simple. The unit consists of a pipe (Lc) and a cone (Zc), as presented in Fig. 1. The gas is pushed into a pipe through a small tangential inlet, which causes the gas to start spinning at very

high velocities against the pipe wall. This causes a vortex of particle-laden gas pushing against the side of the barrel and downwards [9]. The dust is centrifugally forced to the outside of the vortex, falls down into the cone and out through the bottom orifice. Because of the smaller diameter of the lower part of the cone, the horizontal inward forces on the gas increases drastically, forcing it inwards and upwards. The clean gas now forms a smaller vortex of reversed spin inside the eye of the outer vortex and exits through a top outlet [1].

Cyclones are known to be used as pre-cleaners, since they are more efficient in removing larger particles (100 μm) from the gas. However, the plasma generated syngas relevant to this study contains much smaller particles than normal off-gas. Thus a high efficiency cyclone has to be used [1]. During cyclone design, 'efficiency' always refers to the percentage particles of a certain size that are removed from the gas stream. High efficiency cyclones are designed to remove up to 100% of a specified particle size. The inlet and outlet apertures of high efficiency cyclones are usually quite narrow. They also have longer barrels and tangential inlet pipes, differing from the curved inlets required for medium efficiency cyclones [6]. Furthermore, high efficiency cyclones are known to remove much smaller particles. According to Pell et al. [5], high efficiency cyclones have been known to remove 98% of fly ash with an average particle size of 0.1 to 2 μm . These results were attained using a 2D2D cyclone, also discussed by Wang [9].

The 2D2D, 1D3D and 1D2D are the most commonly used cyclone designs. The D's refer to the diameter of the pipe, whereas the number describes the relation of first the pipe and then the cone lengths to the diameter of the barrel. A high efficiency cyclone works on the same principle as a normal cyclone, however, the relation between the lengths of the cone and pipe differs. The longer the cone, the more efficient the cyclone. This explains why the 2D2D cyclone is the most efficient in removing small particles from a gas stream.

B. Parameters that affect the Design

Sizing of a cyclone is dependent upon the properties of the specific system. The characteristics of the gas and the particles are used as basis. Certain design parameters will also be set during the sizing process, so as to obtain the required separation efficiency. The following parameters should be taken into account.

1. The Particle Size Distribution

A cyclone operates using centrifugal forces to increase the gravitational pull on the particles. Lighter particles will experience a less powerful pull [5], therefore requiring a longer pipe length [7]. The particle size is directly related to the cyclone sizing by the parameter d_{pth} (also known as d_{50}). This is the particle size removed by the separator at 50% efficiency. The particle size d_{100} , on the other hand, is the particle size that the cyclone can remove with 100% efficiency.

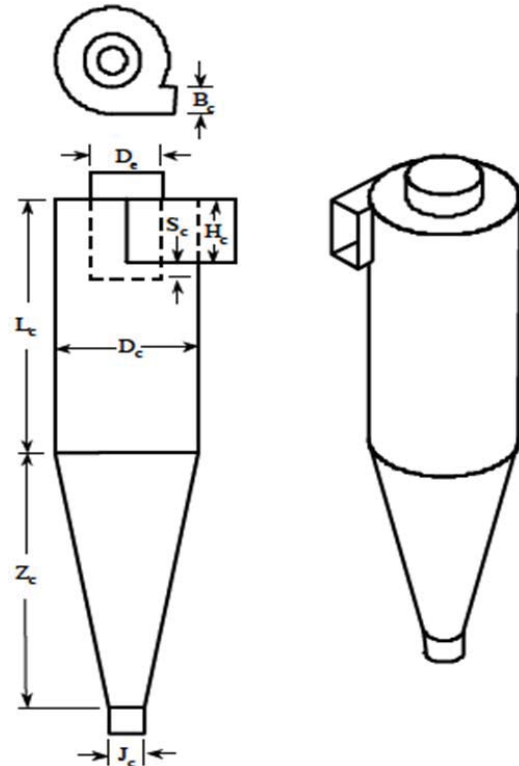

Fig. 1 Type 2D2D cyclone as presented by Wang et al. [7]

2. The Particle Concentration

According to Pell et al. [5], the efficiency rises drastically for higher particle concentrations. At higher concentrations, it was experimentally found that the cyclone removed smaller particles more efficiently. This might be because the larger, coarser particles collided more with the fine particles in the gas, which favours coagulation [5].

3. Other Particle Properties

The moisture content and aerodynamic properties of the dust also affect the cyclone design. Both these aspects affect the movement as well as the density of the gas-solid stream [1].

4. Gas Properties

Higher inlet gas velocity is known to improve removal efficiency, but is usually limited by the pressure drop. High velocity also causes a longer vortex, which could cause re-entrainment of the removed ash if the vortex touches the bottom of the cone [5].

Gas viscosity and gas temperature also influences the design. Gas viscosity increases with temperature [3], which negatively affects the removal efficiency. In a study done by Patterson and Munz [5], it was found that increased temperatures only lowered the separation efficiency of particles of diameter 10 μm and smaller.

5. Number of Effective Turns

According to Wang [9], the number of effective turns (N) is a basic design parameter. It is an indication of the number of

times a specific particle will spin in the outer vortex. A larger number of effective turns will result in a higher efficiency [9].

Numerous studies have been done to relate the number of effective turns to the collection properties of the cyclone. Relations between the d_{50} and d_{100} particle size parameters and the optimal values for the number of effective turns for the 1D2D, 2D2D and 1D3D cyclones are given in Table I, as summarized by Wang *et al.* [8]. All symbols are described fully in Table VI.

TABLE I
 PARAMETRIC RELATION OF NUMBER OF EFFECTIVE TURNS [8]

Relation between Parameters	Optimum Value for N
$d_{100} = \left[\frac{9\mu b}{\pi\rho_{solids}V_iN} \left(1 - \frac{b}{D} \right) \right]^{\frac{1}{2}}$	1D2D: N = 0.51
	2D2D: N = 0.69
	1D3D: N = 0.73
$d_{50} = \left(\frac{9\mu b}{2\pi\rho_{solids}V_iN} \right)^{\frac{1}{2}}$	1D2D: N = 1.92
	2D2D: N = 1.61
	1D3D: N = 1.62
$d_{100} = \left(\frac{9\mu D_e}{2\pi\rho_{solids}V_iN} \right)^{\frac{1}{2}}$	1D2D: N = 0.84
	2D2D: N = 0.92
	1D3D: N = 0.97

6. Pressure Drop

The pressure drop across the cyclone length is inversely proportional to the particle concentration present in the gas. According to Pell *et al.* [5], this could be because the solids reduce the horizontal outward force on the cyclone walls by enlarging the downward pull inside the vortex. For the same reason, the pressure drop also decreases with increasing pipe length.

A cyclone is usually designed by adding an upper limit to the pressure drop. This has to do with the force on the wall and the structural strength of the cyclone [5]. However, since the cyclone that will be used in the plasma gasification system needs to be insulated (with suitable insulating material) to protect the user from the high temperature of the gas, it will be able to handle higher pressures.

7. Other Factors Affecting Cyclone Efficiency

Except for the basic design model for the cyclone design, there are plenty of other factors that also affect the efficiency of the dust removal system. According to Pell *et al.* [5], the roughness of the cyclone walls influences the efficiency. Since roughness on the cyclone walls reduces the velocity of the gas vortex, this will decrease the amount of dust removed from the gas. This implies that the choice of construction material will have a small effect on the cyclone efficiency.

For the same reason, bends in the gas outlet pipe close to the cyclone system will also decrease the efficiency. Lowering the inlet velocity of the gas also lowers the gas throughput, which in turns lowers the efficiency [1].

Re-entrained of the particles could also be a problem, because the gas vortex is known to reach into the top of the outlet. For this reason, it is advisable to avoid placing any kind of restriction or flow valve near the apex. If indeed a flow valve must be used, placing it about one diameter length or more under the discharge orifice should be sufficient to prevent the particles from re-entering the clean gas stream [6].

It is also important to note that the positioning of the cyclone has no effect on its efficiency. The dust is centrifuged because of the overpowering forces inside the vortex. It then leaves the cyclone through the bottom orifice because of a pressure gradient, as well as a combination of the axial and tangential velocities [7]. For this reason, the dust will leave the cyclone at the same rate regardless of whether the cyclone is placed vertical or horizontal to the ground – except when very large particles are to be removed, in which case gravity starts to play a role [6]. Therefore, the cyclone can be placed as required with regards to the reactor system.

C. Design Methodology

In order to design the gas cyclone separator, a number of procedures were examined. In the end, these were narrowed down to two methods, namely the Empiric Method (also referred to as the Classic Method) and the Flow Characteristics Method.

For the classic empirical design method, the relationships between the design parameters were found after extensive laboratory testing of cyclone characteristics. For example, studies were done specifically to relate the number of effective turns to the maximum velocity of gas through the barrel [5]. By doing this, an optimum point was found to improve future designs. This was done for each cyclone parameter, until the cyclone correlations were experimentally optimized. The second design, however, is based on the gas's flow characteristics. Using flow kinetics, mathematical models were found for a gas moving through a cyclone-shaped vessel. After finding correlations between the vessel size and the flow characteristics, dimensionless groups were used to adapt the model for geometrically similar cyclones [6]. These two methods lead to the sizing of two cyclone test units, of which both were manufactured with the objective of comparing the design efficiencies under laboratory conditions.

Both of the cyclones were sized using the relationship between the cyclone parameters for a 2D2D cyclone, as given by Wang [9] and corresponds to the physical parameters as shown in Fig. 1.

$$B_c = \frac{D_c}{4} \quad (1.a)$$

$$D_e = \frac{D_c}{2} \quad (1.b)$$

$$H_c = \frac{D_c}{2} \quad (1.c)$$

$$J_c = \frac{D_c}{4} \quad (1.d)$$

$$S_c = \frac{D_c}{8} \quad (1.e)$$

$$L_c = 2 \times D_c \quad (1.f)$$

$$Z_c = 2 \times D_c \quad (1.g)$$

Both cyclones were designed with the same basic conditions, as shown in Table II. These quantities were

provided by Necsa and confirmed by doing a basic mass balance over the reactor. These values can thus be used as basis for both designs.

TABLE II
 BASIC DESIGN PARAMETERS

Volumetric flow in (Q)	0.016 m ³ /s
Solid Concentration	20 g/m ³
Mass% solids	2%
Mass% gas	98%
Temperature	1000 °C
Pressure	1 atm

To meet the design specifications, the cyclone separator must be able to remove more than 90% of the particles in the feed gas. The particle size under consideration is 50 μm, which is the average measured size of the fly ash at the operating conditions.

D. The Classic Empirical Method

Equation (2) is given by Pell et al. [5] as a basic design equation relating the particle size (d_{pth}) to the stream characteristics, cyclone inlet size (B_c) and number of effective turns (N):

$$d_{pth} = \sqrt{\frac{9\mu_g B_c}{\pi N v_{max,1} (\rho_{solids} - \rho_{gas})}} \quad (2)$$

where ρ_{solids} is the density of the solids, ρ_{gas} is the carrier gas's density (the density of syngas, in this case), and v_{max} is the maximum velocity of the gas through the cyclone. Please note that all parameters are described in full in Table VI.

Since the size of the inlet opening is proportional to every other cyclone dimension, determination of this parameter in effect sizes the whole of the cyclone separator. This implies that, by determining the gas characteristics and the number of effective turns, (2) can be used to size the cyclone.

The number of effective turns can be calculated by relating it to the size of the cyclone. According to Wang *et al.* [7], the number of effective turns for the classical design method can be calculated by (3), which relates N to the cyclone's dimensions, as shown in Fig. 1.

$$N_e = \frac{1}{H_c} \left[L_c + \frac{Z_c}{2} \right] \quad (3)$$

However, calculating any one of these dimensions effectively sets the values for every other cyclone dimension. Therefore, the following process was followed to size the separator. A value for B_c was estimated, producing a value for every other cyclone separator dimension. The characteristics of the gas were calculated and a value for d_{pth} was chosen. The parameter d_{pth} (or d_{50}) is the particle size that will be removed with 50% efficiency by this cyclone. Choosing this value as 50 μm (the typical particle diameter at this temperature), causes the cyclone to be at optimum efficiency for the characteristics of this specific system. Using (2), $v_{max,1}$ was calculated.

The area of the cyclone inlet was calculated using the estimated value of B_c . The velocity of the gas leaving the

reactor was found from the mass balance over the reactor. By assuming the maximum velocity equal to the inlet velocity, as suggested by Pell et al. [5], v_{max} was calculated a second time using (4):

$$v_{max,2} = \frac{Q}{B_c \times H_c} \quad (4)$$

The error between the two velocity values is calculated using (5). An iterative process was used to find the most appropriate design value for B_c . By minimizing the calculated error while allowing only changes to the value of B_c , the difference between the two velocity values will approach zero. H_c will automatically be adjusted as input parameter using (1). In so doing, the all the cyclone parameters are known.

$$error(v_{max}) = (v_{max,1} - v_{max,2})^2 \quad (5)$$

E. The Flow Characteristic Method

The design of the larger cyclone separator was based on mathematical models of the flow characteristics of a gas through a cyclone-shaped vessel. This method uses the Euler and Stokes numbers, both of which are constant for geometrically similar cyclones (such as the 2D2D cyclone type). It should be noted that these numbers are independent of the Reynolds number for cyclones with a barrel diameter larger than 0.01 m [6].

The first step in calculating the dimensions of the larger cyclone was similar to that of the small cyclone, namely estimating the first parameter. In this case, a value for D_c was estimated and all the other dimensions were related to this value via (1). Using these basic parameters, the flow characteristics and dimensionless numbers could be determined. According to Wang *et al.* [7], the Euler number is highly dependent on the inlet velocity of the gas and not necessarily on the body diameter of the cyclone. The characteristic velocity of the cyclone is therefore important. This velocity can be taken either as the velocity of the gas turning through the cyclone's barrel, the outlet velocity of the gas, or the inlet velocity of the gas. Using the inlet velocity is usually more accurate, since most cyclones are designed to produce a lower outlet velocity than inlet velocity [5]. For this reason, the characteristic velocity was calculated as follows:

$$v_{characteristic} = \frac{Q}{B_c \cdot H_c} \quad (6)$$

where Q is the volumetric flow rate into the cyclone, and B_c and H_c are the inlet and outlet diameters respectively. The second variable to be calculated was the Stokes number (Stk_{50}), which quantifies the relation of the centrifugal force to the drag force and also describes the separation performance for a certain cyclone configuration. This dimensionless group uses the relation between the cut size of the particle separation (d_{50}) to the grade efficiency (the cyclone efficiency independent of feed size and coarseness distribution):

$$Stk_{50} = \frac{d_{50}^2 \cdot \rho_{solids} \cdot v_{characteristic}}{18 \cdot \mu \cdot D} \quad (7)$$

where μ is the gas viscosity and D is the cyclone's barrel diameter. Using the Stokes number, the Euler number can now be calculated, because of the empirical relation between the Euler and Stokes numbers for a well-designed cyclone [6]. High values of the Euler number (a resistance coefficient) has been found to correspond with low values of the Stokes number (implying high efficiencies and small particle cut sizes).

$$Eu = \sqrt{\frac{12}{Stk_{50}}} \quad (8)$$

From the Euler number, the static pressure drop across the cyclone body can be calculated. Note that the total pressure drop may also be used [6]; however, the difference is negligible seeing as the ratio of the inlet and outlet velocities over the fixed geometry of the cyclone are constant. Because the inlet and outlet velocities are comparable, an assumption can be made that the kinetic energy of the outlet gas compares to the inlet value [6]. In this case, the static pressure drop will be used, simply because it is more convenient.

$$\Delta p = \frac{Eu \cdot \rho_{gas} \cdot v^2_{characteristic}}{2} \quad (9)$$

Using the dimensionless Euler number, the cyclone flow characteristics can be applied to any cyclone type. The barrel diameter for the 2D2D cyclone type is now calculated [6].

$$D_c = \sqrt{\frac{4Q}{\pi} \sqrt{\frac{\rho_{solids} \cdot Eu}{2 \cdot \Delta p}}} \quad (10)$$

Using this calculated value for the barrel diameter, the initially estimated parameters can be corrected once more by using an iterative solving method which minimizes the error between the calculated diameter and the estimated diameter. The error value was calculated using (11).

$$error(D_c) = (D_c (calculated) - D_c (guessed))^2 \quad (11)$$

The dimensions and characteristics found for the two cyclone designs are summarised in Table III.

III. EXPERIMENTAL

A. Introduction

After the design, the two units were manufactured from clear Perspex for conducting laboratory tests. The primary goal was to test and compare the two cyclone separators and to select the one best suited for the PlasWEn waste-to-energy system. Therefore, the tests were conducted, so as best to simulate the system conditions. The gas flow velocity, particle load, as well as particle size were chosen with this main goal in mind. At room temperature, the syngas' higher temperature was simulated by the lower viscosity gas.

TABLE III
 DESIGN OUTSETS

	Small Cyclone	Larger Cyclone	
B_c	10	14	mm
D_c	38	56	mm
D_e	19	28	mm
H_c	19	28	mm
J_c	10	14	mm
S_c	5	7	mm
L_c	77	113	mm
Z_c	77	113	mm
Angle of inlet	8	8	°
Volume flow through B_c	85.19	39.48	m/s
$\Delta P (max)$	29.03	29.03	kPa

The secondary goal of these tests was to compare the effect of different gases on the cyclone efficiencies. For this reason, air, nitrogen and helium were chosen. Air was used to create a base case at room temperature. Nitrogen is an important component of syngas, since it remains inert throughout the gasification process, and was found to be the third largest component mass fraction present in the product gas. Helium has a much lower viscosity than either air or nitrogen and therefore, offers a fair representative for elevated temperatures.

The first step of the experimental procedure was to compute the flow rate for each gas so as to simulate the flow of syngas from the waste to energy system. This was done using the relative densities of the gases. Hereafter, calibration data for the flow meter was created using the data provided by the manufacturers. The flow was adapted for pressure and density, and the following flow conditions were found for each gas to replicate the design parameters.

TABLE IV
 EXPERIMENTAL CONDITIONS FOR VARIOUS GASES

Gas	Mass Flow (g/s)	Pressure from cylinder (bar)	Dust Load (g)
Air	15.6	8	5.895
Nitrogen	15.1	8	9.666
Helium	2.2	5	8.907

B. Experimental Setup

The experimental setup was done so as to mimic the behaviour of the actual waste to energy system. The basic components of the system were a gas cylinder, a pressure gauge, the flow meter, a venturi with its attached feed-funnel, and a cyclone. An additional gas cylinder filled with nitrogen was added to the system to create a negative pressure over the T-piece venturi so that the fly ash could be sucked into the process gas. The flow of gas from this cylinder into the cyclone is negligible in comparison to the primary gas flow. A high pressure regulating valve was attached to the primary outlet of the cylinder. The reading on the flow meter, however, was controlled by a second flow valve that was positioned just before the flow meter. For each gas, the flow meter was calibrated beforehand. During the experiments, the gas flow remained stable at that specific flow setting.

The cyclone separator and dust collector vessel was inserted after the merging of the two gas lines. The cyclone setup consisted of the Perspex cyclone test unit, mounted on a thick plastic lid by screw fitting on the top, as presented in Fig. 3. The lid was then fitted to a plastic dust collecting vessel that

could easily be removed in order to weigh the contents. A large fabric filter bag was attached to the top of the cyclone separator in order to catch the last bit of fly ash left in the cleaned gas stream. The final experimental setup is schematically presented in Fig. 2.

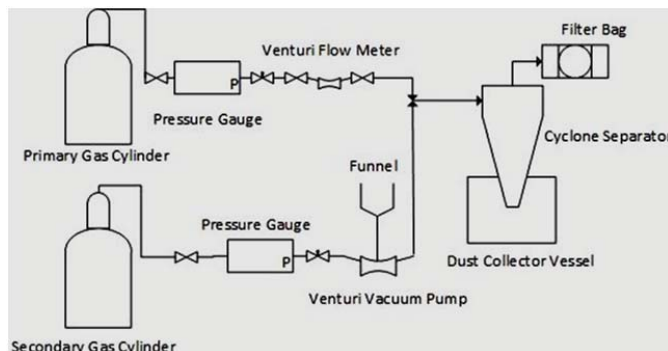

Fig. 2 Experimental Setup

C. Observations

Since the fly ash was black, the propagation of the ash through the system was easily followed. The black ash formed highly visible rings (effective turns) inside the Perspex cyclone. These rings would amplify and fade as the fly ash concentration increased and decreased. For the one particle size, the rings always formed at the same position in the cyclone, so that the walls were lightly stained after three runs with nitrogen as feed gas. For the small cyclone, one clear ring was formed in the barrel (L_c , Fig. 1) and a few in the cone (Z_c , Fig. 1). For the larger cyclone, about three to four rings formed in the barrel, and less in the cone. For different feed gases, the position of the rings shifted slightly.

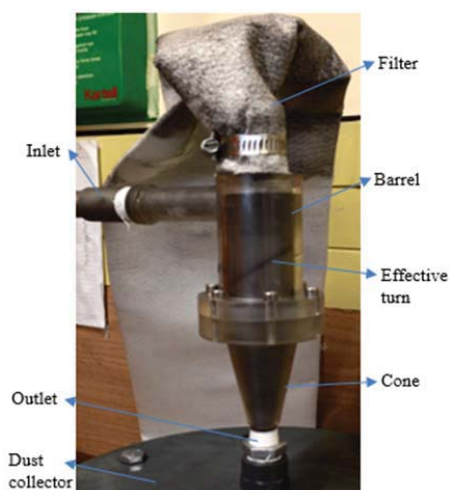

Fig. 3 Running of the small cyclone

Because the experiment was conducted so as to simulate the actual system flow conditions, the volumetric gas velocity, pressure, dust loading and flow meter reading were adapted for each gas in relation to expected conditions for the flow of syngas leaving the reactor. The only parameters that differed

from the actual system conditions were the temperature and the structure of the gas.

The effect of the molecular gas structure was minimized by choosing nitrogen as an experimental gas, since it is one of the three main components of syngas. However, the influence of the molecular structure of the gas should have little influence on the cyclone efficiency.

The influence of the temperature difference, on the other hand, should be observed to a certain degree by choosing a less dense, more viscous experimental gas such as helium. Except for the logical conclusion that a denser gas can support the fine particles with greater ease, viscosity is an important parameter used during the both design methods. Density is also used during the Flow Characteristics Design Method. This implies that the larger cyclone should be doubly influenced by the experimental conditions.

Even though the experimental setup was done with the aim of simulating the PlasWen system as far as possible, the fact remains that the experiments were conducted at room temperature, whereas the cyclones were designed to run at 1000 °C with syngas as feed gas. For both the smaller and larger cyclones, the efficiencies are expected to improve under design conditions.

D. Results and Discussion

Three experimental runs were completed for both cyclones with each gas, respectively. A basic material balance was done to determine how much dust was removed from the loaded feed stream. The resultant average efficiencies for the two cyclone separators over all the runs are shown in Table V.

As seen, both the cyclones showed an efficiency of more than 90%. This implies that the effect of the system temperature on fly ash removal is minimal. However, the effect is not negligible, as can be seen in the difference in efficiency when helium is used as feed gas in comparison to the other two gasses. First, the effects of the different gases on the cyclone separators were compared.

TABLE V
 RESULTANT AVERAGE CYCLONE EFFICIENCIES

	Small Cyclone (%)	Large Cyclone (%)
Nitrogen	98.25 ± 1.17	97.79 ± 1.81
Helium	94.96 ± 0.83	98.37 ± 1.39
Air	97.80 ± 1.67	96.55 ± 2.24

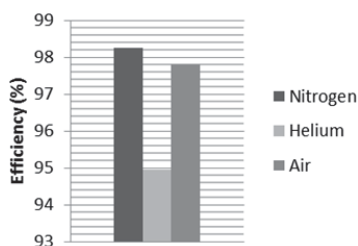

Fig. 4 Removal efficiency of the small cyclone

As seen in Fig. 4, the small cyclone is more temperature sensitive than the larger cyclone. Its efficiency drops with about 3% for helium. The Classic Design Method is therefore less adaptable to high temperature systems.

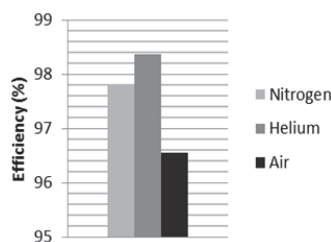

Fig. 5 Removal efficiency of the large cyclone

The larger cyclone, on the other hand, showed an improved removal efficiency for helium. In fact, it was found to be so sensitive to density and viscosity that the efficiency of the cyclone rose as the density of the gas declined. This was expected: the design procedure employed both the density and viscosity of the gas to calculate the cyclone size, whereas the smaller cyclone's design process only required the gas viscosity. For this reason, it can be concluded that the larger cyclone is very sensitive for the system temperature. From these results, it becomes clear that the larger cyclone is more adaptable to changes in the feed gas properties, such as high temperatures. The smaller cyclone, on the other hand, is more robust in the sense that it is less strongly affected by changes in the feed parameters. Nonetheless, both of the cyclones were able to clean the loaded syngas as required in the Project Specifications (above 90% for 50 µm fly ash particles). The average values for the cyclone efficiencies were found to be between 94.96% and 98.37%. The maximum value measured was 99.89%; the lowest attained efficiency was 94%, which still falls within the required specifications.

Seeing as the Plasma Waste-to-Energy System could be operated commercially by private owners, the more robust cyclone might be the more attractive option. Then again, if the temperature control of the plasma reactor is adequately reliable, the larger cyclone should be used, since it will produce a cleaner product stream, as well as recycling more

dust back into the reactor. These factors should be taken into account by Necsa when making the final decision concerning the cyclone size, even though the differences between the two designs are very small.

E. Experimental Error

The possibility of errors for these experiments should also be discussed. The largest source was a small amount of fly ash leakage from the dust collection bucket, which led to an underestimation of the efficiencies of the cyclones. This error could clearly be seen during the experiments, because of the prominent colour and buoyancy of the ash. The second possible source of error was the fly ash that might have remained in the funnel on top of the venturi and never entered the cyclone.

Some immeasurable inaccuracies may also have been present, due to human error. For example, the fly ash samples were weighed by hand on a laboratory balance and the accuracy of the measurements may fluctuate slightly.

All of the above mentioned errors are precision errors, seeing as they arise from varying experimental conditions and were not necessarily present to the same extent for each run.

To quantify the error, the standard deviation is used. This is a convenient way of quantifying the degree of scatter for a certain experiment. A large standard deviation value is usually undesirable, since it shows that the data was inconsistent and not very reliable. Anything under 5% is usually seen as adequate and shows good repeatability.

As seen in Table V, these values are all below 5%, implying that the data maintains quite a high degree of precision. The highest standard deviation is 2.24% and the lowest 0.83%. The experiments are therefore repeatable.

Graphs of the standard errors for each gas are shown in Figs. 6 and 7. In both of these graphs it can clearly be seen that the error for helium is lower than that of the other two gases. Since helium closer resembles (in chemical properties such as density and viscosity) the syngas for which these cyclones were designed, it can be deduced that the cyclones achieve more constant results under design conditions. The error is therefore lower.

Another interesting observation can be made concerning Fig. 6. By adding the error margins to the graph, it becomes apparent that the efficiency data for removing fly ash from air and from nitrogen persistently fall within one standard deviation from one another. This means that, taking error into account, the efficiencies can be seen as comparable. Because the chemical properties of these two gases are relatively similar, this could be expected. However, the large cyclone is so sensitive to the properties of the gases that the standard deviations of the gases do not overlap for every run. Here it becomes clear that the small cyclone is not necessarily affected by the small differences in the feed gas (Fig. 7), whereas the larger cyclone most definitely is.

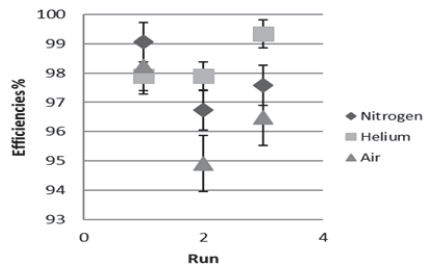

Fig. 6 Large cyclone's removal efficiency with error margins

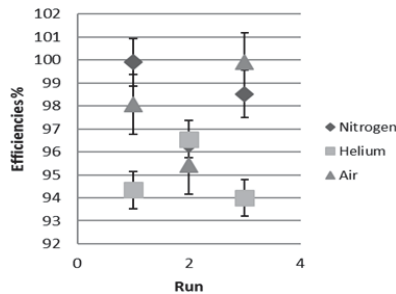

Fig. 7 Small cyclone's efficiencies with various feed gases

IV. CONCLUSION

Even though a cyclone is usually seen as a pre-cleaner, high efficiency cyclones could reach almost perfect separation efficiency and is a good solution for the high temperature PlasWEn system. Two design methodologies were used in an attempt to accomplish the correct design.

The Classic Empiric Method led to the design of a smaller cyclone, which proved to be more robust. The separation efficiency of this cyclone varied less with change in inlet gas and its relation to feed gas density was small. By taking the relationship between temperature and gas density into consideration, it can be noted that higher temperatures will have a negative effect on the separation efficiency of the smaller cyclone.

The second design method (Flow Characteristics Method) employed flow kinetics as design basis. This method allowed the design of the larger cyclone, which proved to be much more sensitive to gas characteristics. The efficiency of this cyclone also improves with lower gas densities – implying better separation efficiency at higher temperatures.

Even so, both of the cyclones accomplished the required separation of 90% and satisfies the design specifications, as agreed on by Necsa. At room temperature, when only the feed gas densities were varied (simulating a very slight temperature rise) the difference in the separation efficiencies of the two cyclone designs was negligibly small. However, the general effects of feed gas density could be seen. At higher temperatures, these minor effects are expected to be greatly amplified. For example, the larger cyclone, for which the separation efficiency rises with lowering feed gas density, is expected to become more efficient in removing even smaller particles. The smaller cyclone, though slightly less efficient, will not react too drastically to fluctuations in the feed gas.

Conversely, these high efficiencies slightly complicate the decision of which cyclone is more suited to be used as part of the PlasWEn system. Both designs would satisfy the requirements. However, the PlasWEn system is designed for commercial use and the reactor fuel is expected to be changeable (unsorted waste can be fed directly into the plasma reactor). This will lead to continuous fluctuations in the density and composition of the syngas. For this reason, it is recommended to install the smaller cyclone as a default separation unit on the PlasWEn system.

V. SUMMARY OF PARAMETERS

The following parameters were used throughout the study.

TABLE VI
DESCRIPTION OF PARAMETERS

Symbols	Descriptions	Unit
b	Diameter of tangential cyclone inlet (round inlet)	m
B_c	Cyclone inlet width (rectangular inlet)	m
D or D_c	Cyclone Barrel Diameter	m
D_e	Clean Gas Outlet Diameter	m
d_{100}	Diameter of particles that cyclone removes with 100% efficiency.	m
d_{50} or d_{pth}	Diameter of particles that cyclone removes with 50% efficiency.	m
Eu	Euler Number	
H_c	Cyclone inlet height (rectangular inlet)	m
J_c	Particle Outlet Diameter	m
L_c	Cyclone barrel height	m
\dot{m}_{gas} relative to syngas	Mas Flow of Test Gas Relative to Syngas	kg/m ³
MW	Mass Flow	g/mole
N	Molecular Weight	
p_i	Number of effective turns	
Δp	Partial Pressure of Component i	Pa
P_{system}	Static Pressure Drop over Cyclone	Pa
ΔP	System Pressure	Pa
Q	Maximum Pressure Drop over the Cyclone Length	kPa
Q_{syngas}	Volumetric inlet velocity of gas	m ³ /s
R	Volumetric Outlet Velocity of Syngas	m ³ /s
S_c	Gas Constant	J/mole.K
Stk_{50}	Difference between Gas Outlet Cone Length and Inlet Height	m
T_{system}	Stokes Number	
V_i	System Temperature	K
v_{max}	Inlet velocity of gas	m/s
$v_{characteristic}$	Maximum gas velocity through cyclone (usually taken as inlet velocity)	m/s
x_{mass}	Characteristic velocity used in flow characteristic design method	m/s
x_{molar}	Mass Fraction	
Z_c	Molar Fraction	
μ_i	Cyclone cone height	m
μ	Component Viscosity	N.s/m ²
ρ_{solids}	Viscosity	Pa.s
ρ_{gas}	Density of particles	kg/m ³
	Density of gas	kg/m ³

REFERENCES

- [1] Amrein, D. L. 1999. How to Select and Maintain a Cyclone for Maximum Efficiency. Louisville: Fisher-Klosterman, Inc.
- [2] Hrabovsky, M. 2011. Plasma aided Gasification of Biomass, Organic Waste and Plastics. Praha, Czech Republic: ICPIG.

- [3] Krieger, F. J. 1951. Calculation of the Viscosity of Gas Mixtures. U.S. Air Force: The Rand Corporation.
- [4] Mountouris, A., Voutsas, D. & Tassios, D. 2005. Solid waste plasma gasification: Equilibrium model development and exergy analysis. (*In* Mountouris, A., Voutsas, D. & Tassios, D., *ed.* Energy Conversion & Management. Athens: Elsevier. p. 1723-1737).
- [5] Pell, M., Dunson, J. B., Knowlton, T. M. 2008. Section 17 – Gas-Solid Operation and Equipment. (*In* Green, D. W. & Perry, R. H., *ed.* Perry's Chemical Engineers' Handbook. 8th ed. NJ: McGraw-Hill. p. 1857-1921).
- [6] Svarovsky, L. 1993. Gas Cyclones. Dordrecht: Kluwer Academic Pub.
- [7] Wang, B., Xu, D.L., Chu, K.W., Yu, A.B. 2006a. Numerical study of gas–solid flow in a cyclone separator. (*In* Yu, A. B. *ed.* Applied Mathematical Modelling. Athens: Elsevier. p. 1326–1342).
- [8] Wang, L., Parnell, C. B., Shaw, B. W. & Lacey, R. E. 2006b. A Theoretical Approach for Predicting Number of Turns and Cyclone Pressure Drop. (*In* ASABE Structures & Environmental Division: 2001 ASAE Annual Meeting. North Carolina: American Society of Agricultural and Biological Engineers. p. 491-503).
- [9] Wang, L. 2004. Theoretical Study of Cyclone Design. Texas: A&M University. (Dissertation – PhD).