

# 3A Distributed Method Algorithm for Exact Side Load Managing Smart Grid Using LABVIEW

N. Ravi Kumar, R. Kamalakannan

**Abstract**—The advancement of hybrid energy resources such as solar and wind power leading to the emergence of customer owned grid. It provides an opportunity to regulars to obtain low energy costs as well as enabling the power supplier to regulate the utility grid. There is a need to develop smart systems that will automatically submit energy demand schedule and monitors energy price signals in real-time without the prompt of customers. In this paper, a demand side energy management for a grid connected household and also smart preparation of electrical appliance have been presented. It also reduces electricity bill for the consumers in the grid. In addition to this, when production is high, the surplus energy fashioned in the customer owned grid is given to main grid or neighboring micro grids. The simulation of the entire system is presented using LabVIEW software.

**Keywords**—Distributed renewable energy resource, power storage devices, scheduling, smart meters, smart micro grid, electric vehicle.

## I. INTRODUCTION

THE conventional power system is facing a lot of problems regarding gradual depletion of fossil fuel resources, environmental pollution, growth of load, etc. These problems have led to the new concept of changing our energy system from a hierarchical design into a set of independent micro grids becomes feasible with the availability of small renewable energy generators like natural gas, biogas, wind power, solar PV cells, fuel cells, combined heat and power (CHP) systems and their integration into the utility distribution network.

Smart micro grids use Distributed Renewable Energy (DER) and enhance the traditional power grid through computing, communications and control technologies through generating, transmitting, distributing and consuming of electricity [3]. The two-way electricity flow and real-time information is an important feature of Smart Grids (SG), which provides various assistances and elasticities to both utility providers and consumers, for matching power supply and demand in a timely manner and improving energy efficiency and grid stability [2]. Nowadays, photovoltaics (PV) are introduced into the electrical system. It is expected that the increasing influence of PVs will eventually change overall load profile significantly. This impact comes from the fact that these elements are mobile elements that do not only ingest power, but can possibly also subsidize current to the

grid. And also most of the residential charge operations will take place during the night. It is believed that the introduction of PVs will modify the behavior of the grid at a very significant scale [6].

## II. EXISTING METHODOLOGIES

Microgrid is an important component for future grid deployment. The grid stability problem is achieved by guaranteeing the quality of usage (QoU) of users in a microgrid under both casual current stream and demand [1]. A sensitivity analysis is made to identify and rank the impact of many uncertainties like variations in temperature, electrical and thermal demand [2]. An optimal joint centralized scheduling algorithm was proposed to control the electricity consumption of both home appliances and plug-in PVs and also to discharge electric vehicles when they have excess energy. It increases the reliability and stability of micro grids and gives lower electricity prices to customers [3], [4]. A framework for smart energy management based on the concept of QOS in electricity was presented. The problem is formulated by stochastic programming problem [5]. Microgrid may block some excellence of usage application if needed. This can be done by integrating smart meters, smart loads and employments that can adjust it and control their service level through statement flows [6].

This work builds on experiences gained from energy management in smart power grid and energy scheduling. Different approaches are investigated for energy scheduling among multiple nearby homes in normal hours and peak hours. Since the price of electricity varies over time, related works focus on scheduling the load to reduce the electricity bill of consumers. The normal hours are considered during the day time when people go to their work and less consumption of power is consumed. The peak hours are considered during the night time during which the power consumption is high. The work concentrates on minimizing energy cost of consumers and to create a low carbon environment using renewable resources. Monitoring of power consumption is done using smart meters and is made to be updated on the website on a daily basis using WAN.

## III. THE PROPOSED SYSTEM

The proposed system consists of a central controller which manages the load and schedules the power generated from the micro grid. It schedules the power in normal and peak hours and also it reduces the power loss by charging and discharging. This effective management of loads needs accurate information in order to help balance supply and

R. Kamalakannan and N. Ravi Kumar are with the Department of Electrical and Electronics Engineering, S.A. Engineering college, Chennai, India (e-mail: kannan.r.kamalakannan28@gmail.com, ravikumar21.rm@gmail.com).

demand. In case of shortage of power generation, they automatically switch to use the energy stored in backup battery bank. The existing system has no real-time monitoring of either the voltage being offered to a load or the current being drawn by it. Also, there is very little communication between the masses and the power system other than the supply of load drive whenever it is demanded. So, the proposed system is stimulated by the internet which offers the possibility of much greater monitoring and control throughout the power system.

A stand-alone micro grid renewable power system has four basic components: 1. A charging system which consists of a solar panel array or a generator or both. 2. An energy storage system which is generally a bank of deep cycle lithium-ion batteries. 3. A charge control system which is used to prevent overcharging of the batteries. 4. An inverter which is used to convert low voltage DC to 110 V AC to power normal household loads.

Microgrid is the promising solution for the present energy crisis which uses wind turbines and photovoltaic panels to generate power. 1 MW solar array and a 1.5 MW wind turbine are used for the charging system, lithium-titan ate batteries are used for battery bank for storage and a 4000 Watt inverter. A battery status meter is also placed in the battery bank that shows the charging time, what the voltage is and how many amp hours (AH) consumed from our battery bank. It will be very useful to calculate and measure the charging and discharging rate of batteries.

Lead acid batteries are extremely well known but they have some issues. They are toxic and very heavy and require maintenance. Other issues are environmental impact and sustainability. Lithium-based batteries offer many advantages.

They are safer because they do not leak hydrogen gas or degrade from exposure to sulfuric acid. The most commonly used battery is lithium-titanate battery which is a kind of rugged battery with high power, fast charge and discharge rates, long life and also a superior power to weight ratio over lithium-ion based predecessors. A charge regulator limits the rate at which electric current is charged or discharged from electric batteries. It prevents overcharging and also protect against overvoltage otherwise it reduces the battery performance or lifespan of battery. It may also prevent from complete draining of a battery or perform controlled discharges depending on the battery technology in order to protect battery life. The inverter used is of MC Thermistor type which is suitable for both high current and high voltage applications.

Fig. 1 shows the overall block diagram of the project. It consists of power generation module which includes the solar and wind energy for generating power. The generated solar power will be in the form of DC. It can be stored directly into the battery bank. The wind energy generated can either be in the form of AC or DC depending on the type of wind turbine used. Batteries run on DC current. This battery power cannot be used for home appliances. So, DC-AC inverter is used to convert DC to AC. The PIC microcontroller is used for controlling the entire grid operation and for scheduling the power supply. It monitors the current and voltage through voltage and current sensors before and after switching. If there is any excess difference in the power distributed, then it considers as power theft or it considers as there is malfunction in one of the power lines and is updated in the micro grid website through WAN.

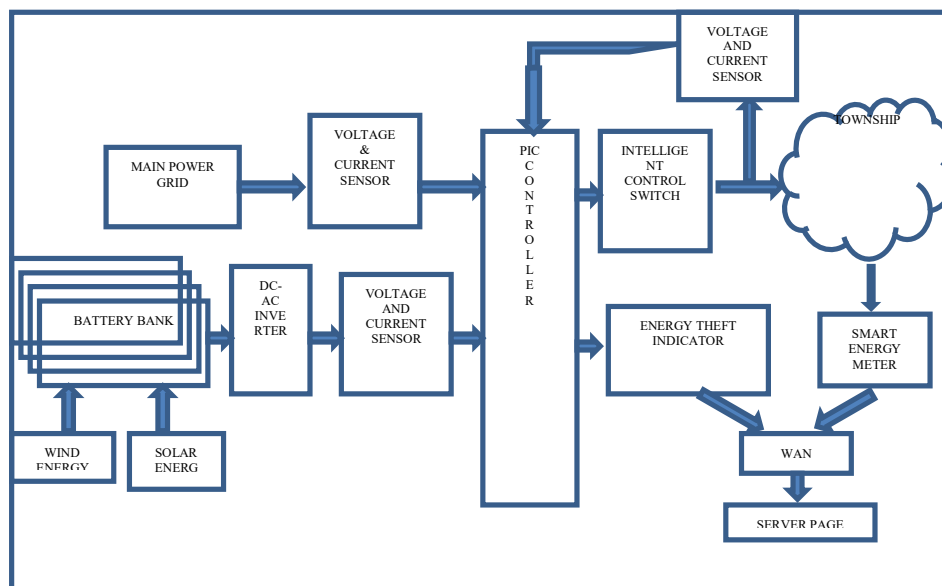

Fig. 1 Block diagram of the project

If distributed energy resource is offline, as backup to the utility grid, circuit breakers or contract based MG switch are preferred as it provides not only switching but also used for

over-current protection. It can be employed in micro grids when large scale battery storage is used. The smart meters have two way communications which are used in order to

provide a real time display of energy use and pricing information.

- i. If micro grid power is not available, it automatically switches over to main grid.
- ii. If main power is available it checks whether it is normal or peak hours.
- iii. If it comes under normal hours it charge batteries and also switches supply from the micro grid.
- iv. If it comes under peak hours first it stops charging the batteries and checks the availability of battery power. If it is available it will switch supply from the micro grid. Otherwise it will switch supply from main grid.

Fig. 2 explains about the flowchart of scheduling technique employed in this project.

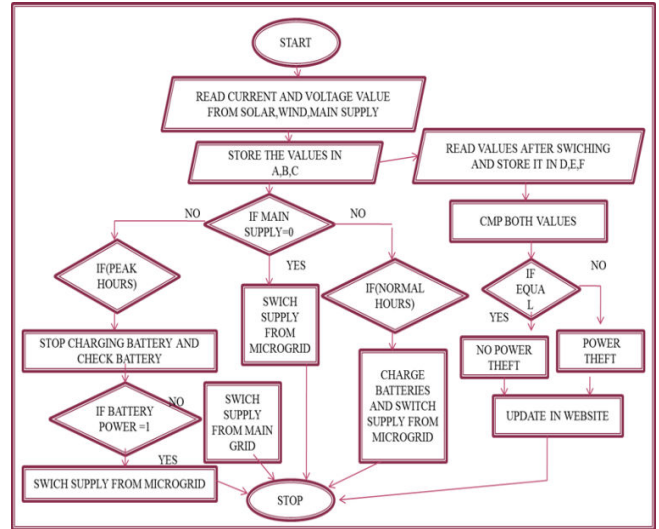

Fig. 2 Scheduling flowchart

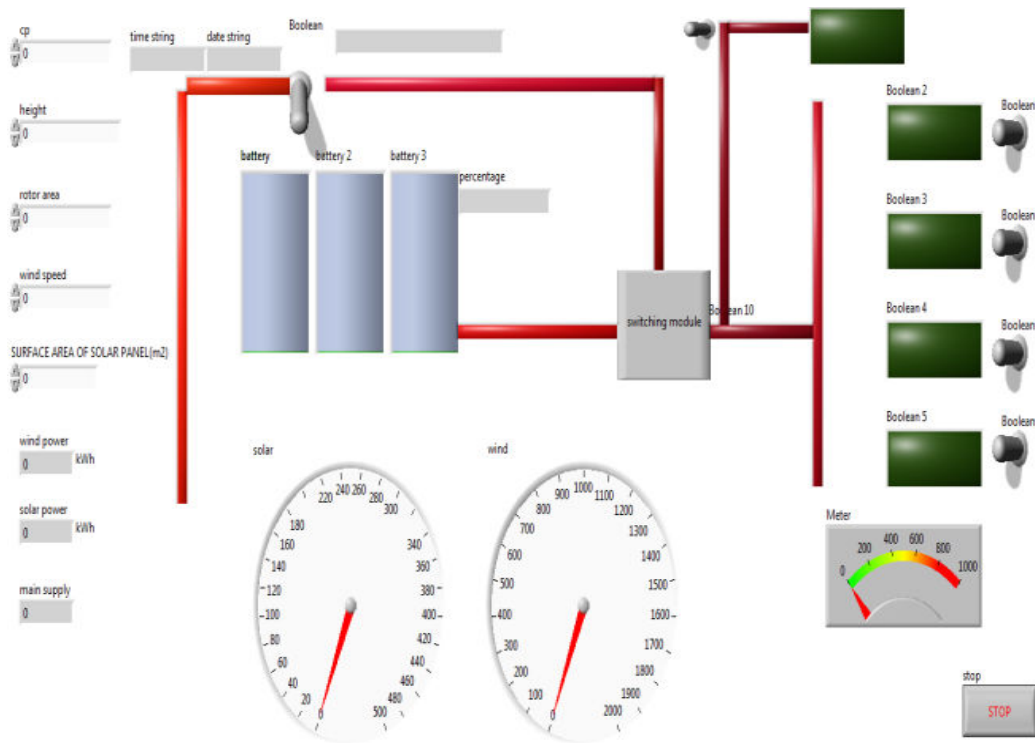

Fig. 3 When microgrid power is not generated and batteries are not charged

#### IV. SYSTEM MODEL AND FORMULATION

The power generation module uses two DERs such as wind and solar. The wind power output can be calculated using (1):

$$\text{Wind Power Output} = P_o = CP \cdot \frac{1}{2} \cdot \rho \cdot A \cdot V^3 \quad (1)$$

where, CP = Maximum power coefficient (value ranges from 0.25 and 0.60),  $\rho$  = Air density ( $\text{kg}/\text{m}^3$ ), A = Rotor swept area,  $\text{m}^2$  ( $A = (\pi D^2)/4$  where D is the diameter (m)), V = Wind speed (mps).

As height increases the density of air also increases. The more the air density, the more the power is generated. The CP is the maximum power coefficient whose value normally varies from 0.25 to 0.59. A 20% increase in the wind velocity increase the power generation up to 73%. For solar power generation solar arrays are used. A solar selection is an interrelated system of lesser PV modules called PV cells/solar cells. These arrays are connected in series to charge a bank of batteries. The solar power output is calculated using (2):

$$P_o = N \cdot \text{Efficiency} \cdot \text{Irradiance} \quad (2)$$

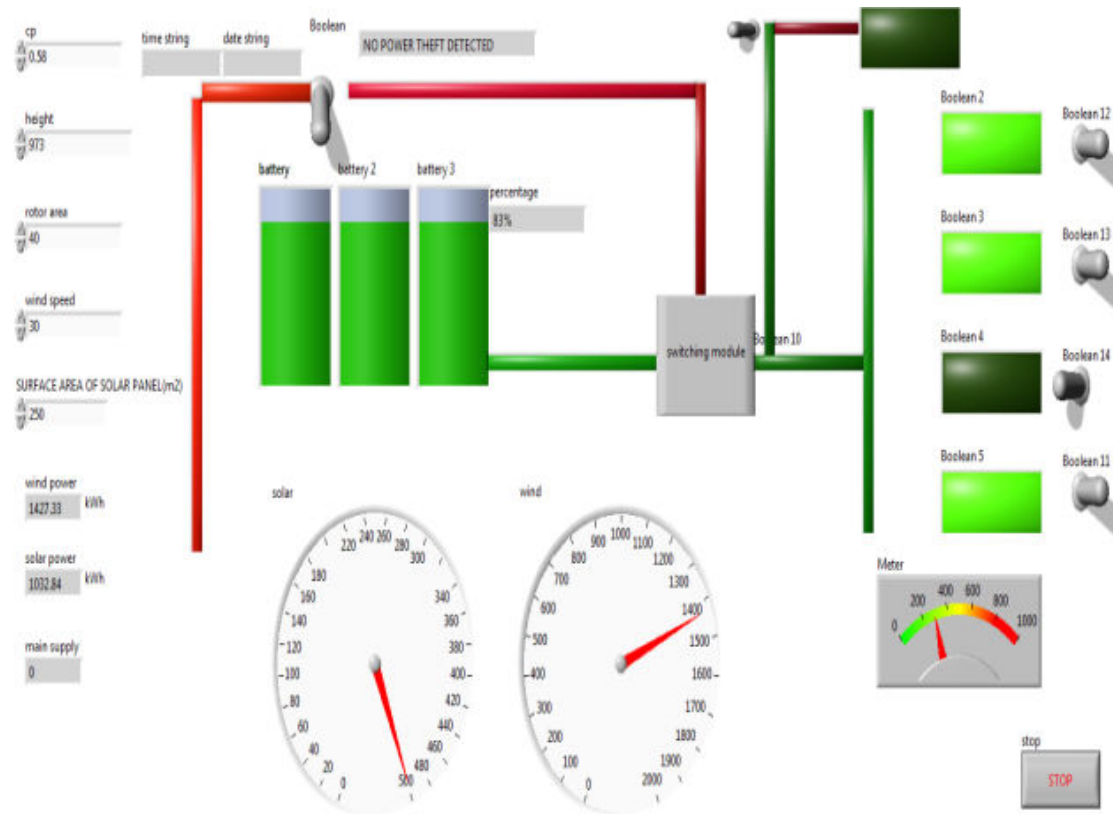

Fig. 4 When battery charges and grid utilizes battery power

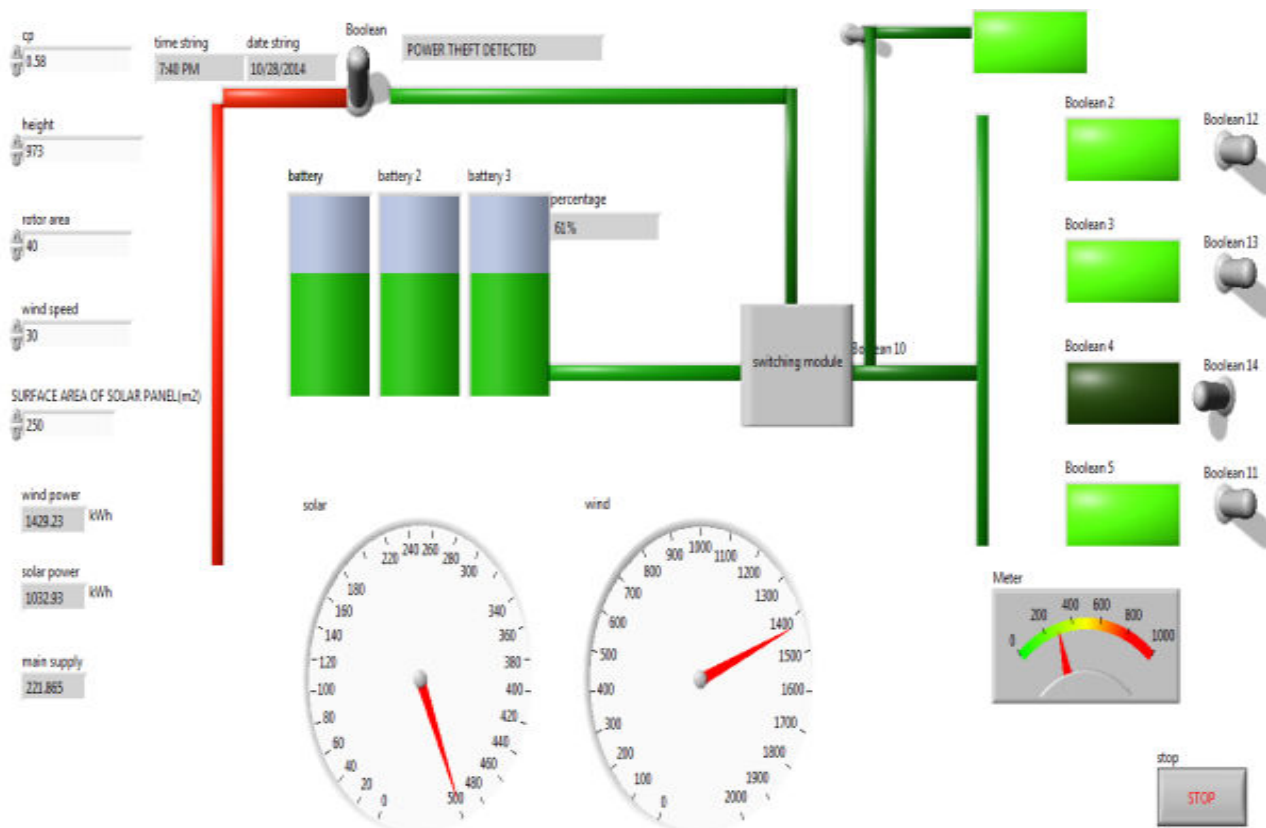

Fig. 5 When battery power discharges and grid utilizes main power

where,  $N$  = No of panels, Efficiency = 0.75 (default), Irradiance = 5.5 (climatic conditions of INDIA).

Irradiance is a measurement of solar power and is defined as the rate at which solar energy falls onto a surface. Solar irradiance is given by power (W)/Area ( $m^2$ ).

The generated power is stored in the sequence bank. The batteries used in the bank are lithium titan ate and are connected in series. It is very effective in producing soothing output because its design is suited to the high rates of charge and discharge in micro grid applications. It also delivers higher efficiency with fewer losses. In order to capture charging and discharging cycles of battery separately, two positive variables are shown in (3):

$$\text{Battery Power} = P(b) = P(\text{in } b) - P(\text{out } b) \quad (3)$$

where,  $P(\text{in } b)$  = Battery input power,  $P(\text{out } b)$  = Battery output power.

The algorithm has two very significant properties:

- i) Load regulation
- ii) Energy or power regulation.

The joint charging schedule optimally regulates power and load, which yields a minimum electricity import needed by the micro grid. The joint centralized scheduling schemes do not depend on several interactions between end systems and the central controller, which is essential for decentralized PV charging control methods to determine the optimal schedule. The joint scheduling policies are capable to accommodate any energy source model.

## V. SIMULATION AND RESULTS

The smart micro grids using renewable energy resources for low cost application are simulated and the results are analyzed in LabVIEW.

## VI. CONCLUSION

This paper presents a centralized scheduling model for scheduling home appliances and PVs in a grid-connected micro grid powered by renewable energy sources to achieve lower operation cost. The micro grid uses lithium-titan ate batteries and PVs as electricity storage to improve the efficiency and reliability of the system. When power is produced in excess, it is exported to non-grid members on cost basis. It is observed that the optimal scheduling schemes clearly perform better by managing the electricity consumption and shifting soft loads from high demand (and/or low power generation) periods to low demand (and/or high power generation) periods. Also smart meters are used to send data immediately to the website designed for the micro grid members to view the details of their power consumption and energy cost per usage.

## VII. FUTURE WORKS

As future study, it is suggested to look into issues such as coordination and scheduling of many micro grids, their power quality and also their participation in energy markets. Energy

storage options and capabilities can be improved in future. The cost of configuring an area as a Micro grid does not justify the reliability benefits, which may be accomplished through other means, such as stoppage generators. Issues such as physical and cyber security of the Micro grids need to be addressed.

## REFERENCES

- [1] Yingsong Huang, Student Member, IEEE, and Shiwen Mao, Senior Member, IEEE "On Quality of Usage Provisioning for Electricity Scheduling in Micro grids" in IEEE Systems Journal, Vol. 8, No. 2, June 2014 Pg: 619-628.
- [2] Mohammad Tasdighi, Student Member, IEEE, Hassan Hisami, Senior Member, IEEE, and Ashkan Rahimi-Kian, Senior Member, IEEE "Residential Microgrid Scheduling Based on Smart Meters Data and Temperature Dependent Thermal Load Modeling" on IEEE Transactions on Smart Grid, vol. 5, no. 1, January 2014 Pg:349-357.
- [3] Christopher O. Adika and Lingfeng Wang "Autonomous Appliance Scheduling for Household Energy Management" on IEEE Transactions on Smart Grid, vol. 5, no. 2, March 2014 673-682.
- [4] Mosaddek Hossain Kamal Tushar, Chadi Assi, Senior Member, IEEE, Martin Maier, Senior Member, IEEE, and Mohammad Faisal Uddin "Smart Microgrids: Optimal Joint Scheduling for Electric Vehicles and Home Appliances" IEEE Transactions on Smart Grid, vol. 5, no. 1, January 2014 239-250.
- [5] Yingsong Huang, Student Member, IEEE, ShiwenMao, Senior Member, IEEE, and R.M. Nelms, Fellow, IEEE "Adaptive Electricity Scheduling in Micro grids" on IEEE Transactions on Smart Grid, vol. 5, no. 1, January 2014 270-281.
- [6] Mingrui Zhang, Member, IEEE, and Jie Chen, Student Member, IEEE "The Energy Management and Optimized Operation of Electric Vehicles Based on Micro grid" on IEEE Transactions on Power Delivery, vol. 29, no. 3, June 2014 1427.