

Analytical Investigation of Replaceable Links with Reduced Web Section for Link-to-Column Connections in Eccentrically Braced Frames

Daniel Y. Abebe, Sijeong Jeong, Jaehyoun Choi

Abstract—The use of eccentrically braced frame (EBF) is increasing day by day as EBF possesses high elastic stiffness, stable inelastic response under cyclic lateral loading, and excellent ductility and energy dissipation capacity. The ductility and energy dissipation capacity of EBF depends on the active link beams. Recently, there are two types EBFs; these are conventional EBFs and EBFs with replaceable links. The conventional EBF has a disadvantage during maintenance in post-earthquake. The concept of removable active link beam in EBF is developed to overcome the limitation of the conventional EBF in post-earthquake. In this study, a replaceable link with reduced web section is introduced and design equations are suggested. In addition, nonlinear finite element analysis was conducted in order to evaluate the proposed links.

Keywords—EBFs, replaceable link, earthquake disaster, reduced section.

I. INTRODUCTION

EBFs have high ductility as in moment resisting frames and high stiffness as in concentrically braced frames. The research works on EBFs were started since mid-1970's Roeder and Popov, (1977) and then by Manheim, (1982) [1]. The principle of EBF design is to confine all the inelastic activities within active links only, and the design is directly related to active link forces in plastic state, the plastic design is considered as most rational approach for EBFs [7]. The disadvantage of using the conventional EBF is that the active link and the collector beam are part of a common floor beam element or the damaged link member is not isolated from the main structures hence the repair of damaged links can be an expensive operation and time consuming task. Furthermore, it may also affect the use of the building. The concept of removable link addresses the disadvantage of the conventional EBF.

In 1994, Ghobarah and Ramadan started the concept and experimental investigation on bolted extended end-plate connections for EBFs with link-column connection configuration [2]. The inelastic performance they found was similar to fully welded connections. In 2003, Balut and Gioncu developed an improved replaceable dog-bone and investigated its advantage and disadvantage. They suggested that in order to

control the formation of plastic mechanisms which provides a ductile behavior of steel frame, the dog-bone should be weaker in strength or less in cross-sectional area than the collector beams. However, the disadvantage of using replaceable dog-bone with less cross-section results in yield differences in structure and that needs exhaustive control [3]. The concept of dog-bone can also apply for removable active link. The disadvantage in section difference is not only difference in yielding strength but also it has some difficulties in construction.

In both conventional EBF and EBF with removable link, the behavior of EBF is controlled by the active link as the ductility and energy dissipation is limited to the active link. The active link length has also a determining factor for links with reduced section as well.

II. DEVELOPMENT AND DESIGN PROCEDURE OF REDUCES SECTION ACTIVE LINKS

Fig. 1 shows the detail of the developed links with shear and bending moment distribution. As shown in the figure, the plastic shear of reduced web section is less than the plastic shear of unreduced section. However, reducing the web section reduction has a slight effect on section plastic moment.

The behavior of link including the rotation capacity depends on link length factor given in (1). Thus, the rotation limit link length factor $r_{w\rho} \leq 1.6$ is 0.08 rad and the yielding type is shear. For $r_{w\rho} \geq 2.6$, the plastic rotation limit is 0.02 rad and the yielding type is flexural. For $1.6 < r_{w\rho} < 2.6$ the rotation limit is found by interpolation between 0.02 rad and 0.08 rad and the yielding type occurred is also combined shear and flexural [4], [5]. Shear, flexural and combined shear and flexural yielding links are also called short, long and intermediate link respectively.

$$r_{w\rho} = \frac{r_{we} e_p V_p}{M_p} \quad (1)$$

where $r_{w\rho}$: non-dimensional link length factor, r_{we} : is the length of reduce web link, $r_{we} V_p$: plastic shear of reduced web link, M_p : is the plastic moment.

The moment equilibrium of link is expressed as in (2) and (3) for reduced web link and unreduced section respectively.

D. Y. Abebe and S.J. Jeong are with the Chosun University, Smart Green Construction Research Center, Gwangju, 501-759, Korea (e-mail: daniel28@chosun.ac.kr, jeongsj@chosun.ac.kr).

J. H. Choi is with Chosun University, School of Architectural Engineering, Gwangju, 501-759, Korea (phone: 82-62-230-7242, fax: 82-62-230-7155; e-mail: jh_choi@chosun.ac.kr).

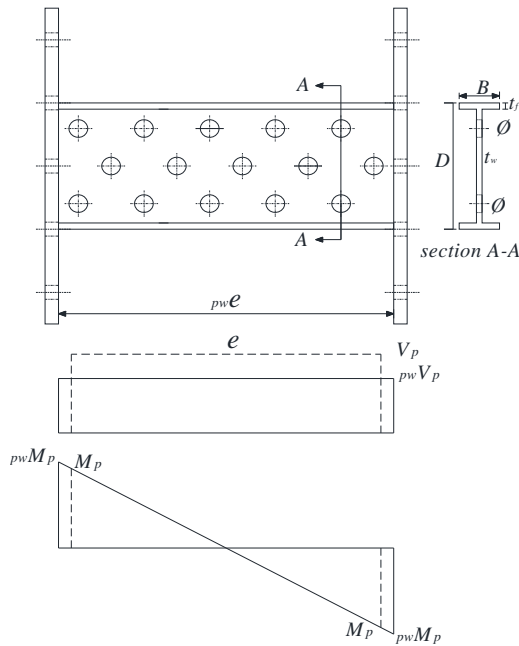

Fig. 1 Shear and bending moment distribution

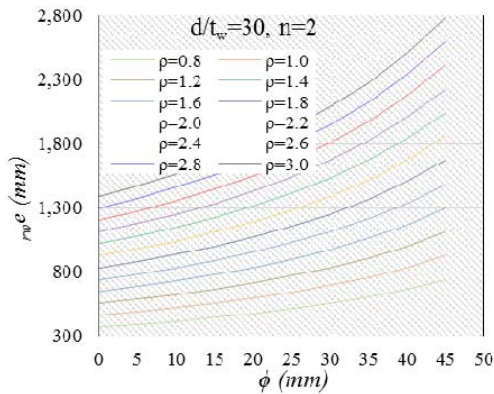

Fig. 2 S Shear and bending moment distribution

$$M_p = \frac{r_w e_{r_w} V_p}{2} \quad (2)$$

$$M_p = \frac{e V_p}{2} \quad (3)$$

Equating (2) and (3)

$$r_w e = \frac{V_p e}{r_w V_p} \quad (4)$$

The plastic shear for reduced and unreduced web can be given by (4) and (5) respectively:

$$V_p = 0.6 f_y d t_w \quad (5)$$

$$r_w V_p = 0.6 f_y t_w (d - n \phi) \quad (6)$$

where f_y : is yield strength, d : link depth, n : is number of perforations in a vertical alignment and ϕ : diameter of perforation as shown in Fig. 1. Substituting plastic shear equations in (4):

$$r_w e = \frac{de}{d - n \phi} \quad (7)$$

where e : is the link length of unreduced section calculated in terms of plastic moment, plastic shear of unreduced section.

Taking web compactness ratio of 30 and flange compactness ratio of 15 (compact section), for W200x150x t_w x10, plastic moment to plastic shear strength ratio will be 0.46 m (for unreduced section). The relationship between the factored link length of reduced beam section and the diameter of perforation for $n=2$ is presented in Fig. 2. As shown in the figure, the length of reduced link section of all link types considered increases as the diameter of perforations or increases.

III. NON-LINEAR FINITE ELEMENT ANALYSIS

Non-linear finite element analysis was conducted using a program called Abaqus 6.12 in order to evaluate the plastic deformation as well as the deformation mode. Large displacement effects were accounted for by utilizing the nonlinear geometry option in Abaqus. The structural steel components are modeled as an elastic-plastic material. With elastic and plastic options, the yield and ultimate tensile strength obtained firstly from the results of the coupon tests called engineering data should be converted into the true stress and plastic strain with appropriate input format for ABAQUS. The engineering data can be converted to true data using (8) and (9). The important parameter to be considered in the plastic range of steel material in the large deformation modeling is the effect of strain hardening characteristics. Strain hardening is an important parameter in material modeling since it determines the hysteresis response. There are three types of strain hardening models commonly used. These are: isotropic, kinematic and combined isotropic and kinematic strain hardening.

$$\sigma_{tr} = \sigma_e (1 + \varepsilon_e) \quad (8)$$

$$\varepsilon_{tr} = \ln(1 + \varepsilon_e) \quad (9)$$

where: σ_{tr} : true stress, σ_e : engineering stress, ε_{tr} : true strain, ε_e : engineering strain.

Tensile tests were conducted on 10, 9, 8, and 7 thickness steel plate. The monotonic tension coupons are conformed to ASTM and the results are summarized in Table I for both and flange materials. Three tensile tests were conducted for each thicknesses and the average values were taken. The yield strengths were calculated using 0.2% offset rule. Fig. 3 shows the final fractured tension coupon result. The parameters considered in finite element analysis were, link length ratio and percent of open area are the main and the details of parameters are presented in Table II.

TABLE I
 THE SUMMARY OF TENSION COUPON TEST RESULTS

Section	Thickness	F _y (MPa)	F _u (MPa)	Elongation (%)
Flange	10 mm	280.37	368.7	51.6
	9 mm	322.7	423.6	38.9
Web	8 mm	299.7	449.4	44.76
	7 mm	308.2	370.4	52.36

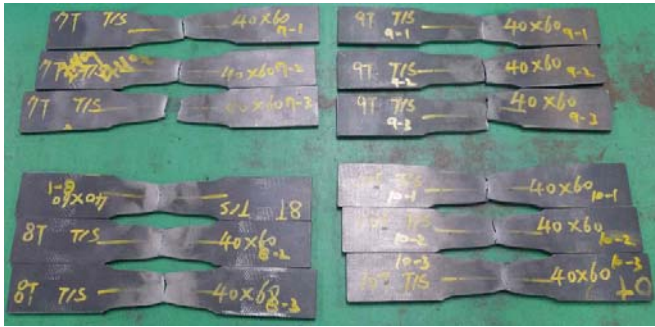

Fig. 3 Fracture of tension coupon test result

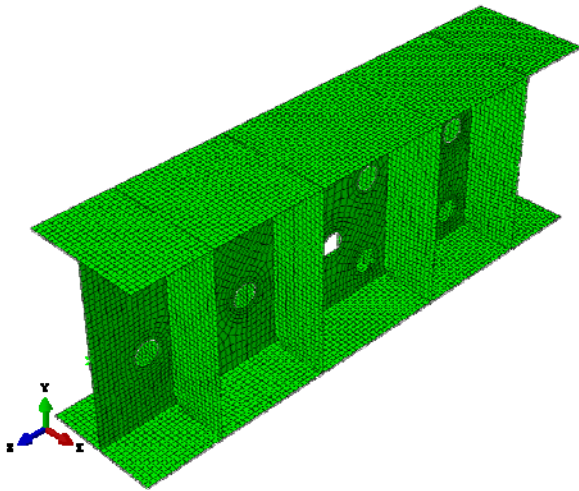

Fig. 4 3D meshed analysis model

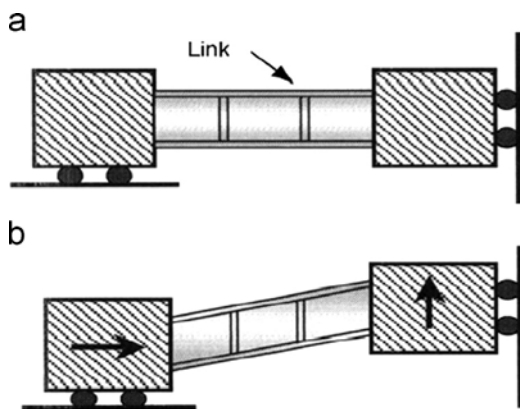

Fig. 5 FEM model boundary conditions applied to the links: (a) initial configuration and (b) deformed configuration

IV. RESULTS AND DISCUSSION OF NON-LINEAR FINITE ELEMENT ANALYSIS

The hysteresis response of the parametrical results of finite

element analysis is presented in Fig. 6 for intermediate link (Sf1) with stiffened and unstiffened specimen having 5% and 10% open area. As shown in the figure, stiffened links have large deformation capacity with slight strength degradation. When the strength started to degrade, the hysteresis response forms pinching at initial displacement. Unstiffened links show stable hysteresis response up to final strength degradation but strength degradation is rapid compared to stiffened links with pinching at initial displacement. A severe pinching is formed in unstiffened links compared to stiffened links. The pinching on the hysteresis curve is due to the out-of-plane buckling of web under cyclic loading and severe out-of-plane buckling was occurred in unstiffened links compared to stiffened links.

The plastic rotation capacity of analysis specimens is summarized in Fig. 7. Two methods were used to calculate the total plastic shear rotation capacity of analysis specimens. The first is the shear rotation at which the strength is decreased and the other method is using failure index. The first method is simple and easy. However, the first method cannot be applied for all analysis specimen as the strength of some analysis specimens keeps stable at large displacement and for these type of specimens, the latter is a preferable method. The failure index (FI) which is defined as the ratio of equivalent plastic strain (PEEQ) and the critical plastic strain as shown in (10). The equivalent plastic strain (PEEQ) and the critical plastic strain (ϵ^{cr}) are computed using (11) and (12) respectively [8].

$$FI = \frac{PEEQ}{\epsilon^{cr}} \quad (10)$$

$$PEEQ = \int_0^t \sqrt{\frac{2}{3} \dot{\epsilon}_{ij}^p \dot{\epsilon}_{ij}^p} dt \quad (11)$$

$$\epsilon^{cr} = \alpha \exp\left(-1.5 \frac{\sigma_m}{\sigma_e}\right) \quad (12)$$

where $\dot{\epsilon}_{ij}^p$ is the plastic strain rate tensor, σ_m is the hydrostatic stress, σ_e is the von Mises stress, and α is a material constant. The ratio of the hydrostatic and von Mises stress is the stress triaxiality. The material is assumed to fracture when failure index reaches 1.0. Thus, the total shear rotation of link is taken at which the failure index reaches 1 even though the hysteresis curve does not show any strength degradation. As shown in Fig. 7, the plastic rotation of analysis specimen decreases with an increase of percent of open areas. The plastic rotation capacity of stiffened links is greater than plastic rotation capacity of unstiffened links. For 5%-15% of open areas all shear links satisfy the plastic rotation limit. Generally, all flexural links do not reach the plastic rotation limit recommended in AISC-10 except three specimens [6]. For intermediate link, the plastic rotation for 5% reduced web area satisfy the recommendation however, as the percent of open areas increase the intermediate links fail to satisfy the rotation level.

TABLE II
 ANALYSIS SPECIMENS DETAIL

$\frac{b_f}{t_f}$	$\frac{d}{t_w}$	V_p (kN)	M_p (kNm)	$\frac{M_p}{V_p}$ (m)	0.8	1.0	1.2	1.6	2.0	2.3	2.6	3.0
9	23	156	60	0.38	306	382	458	611	764	878	993	1146

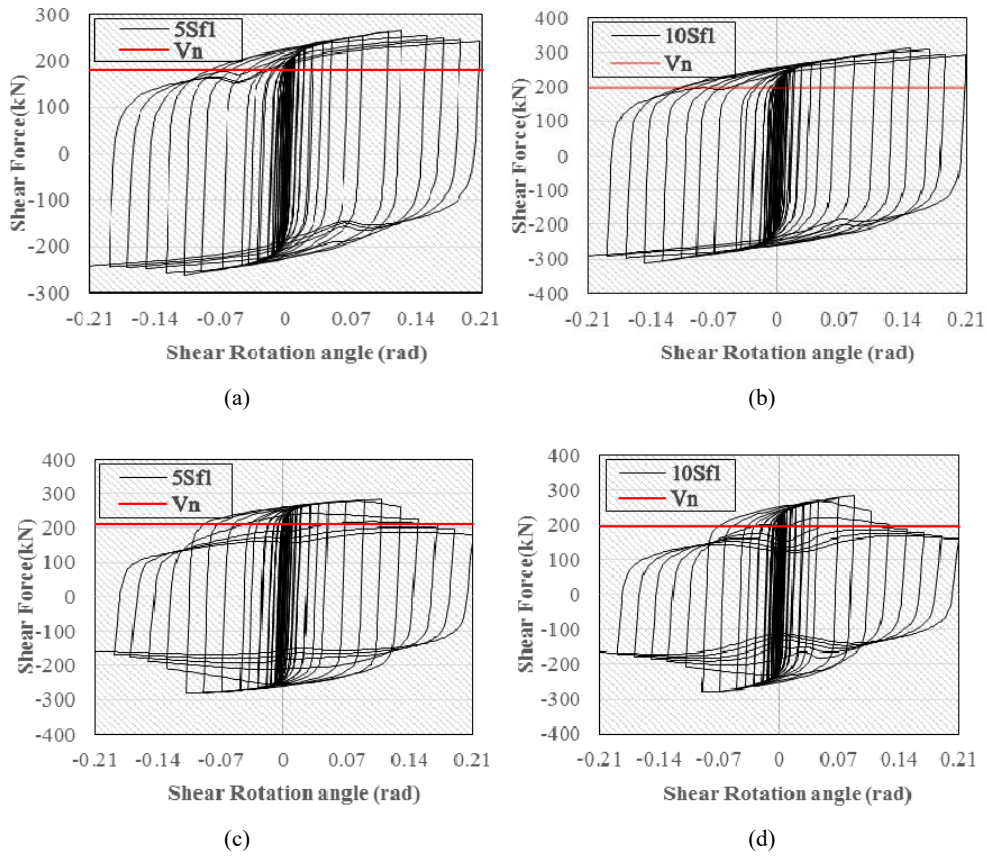
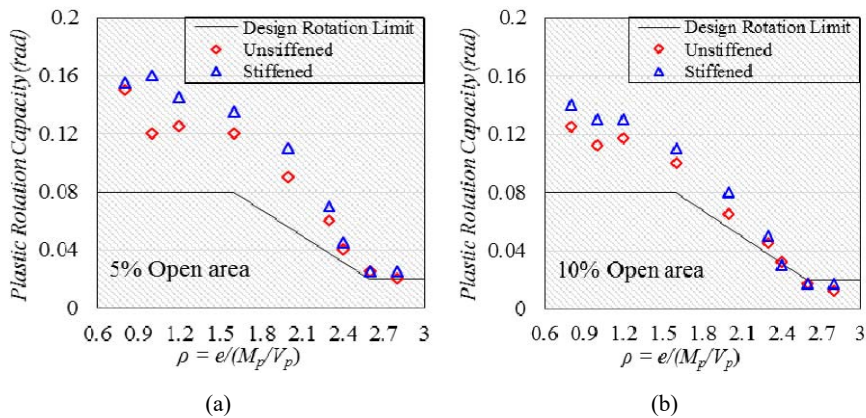

Fig. 6 Hysteresis response of analysis results for stiffened specimens with (a) 5% open area and (b) 10% open area and for unstiffened specimen with (c) 5% open area and (d) 10% open area



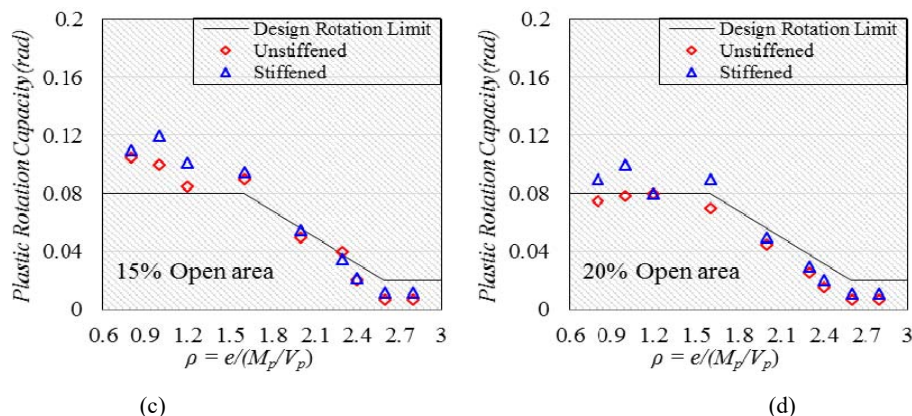

Fig. 7 Plastic rotation capacity versus link length factors for stiffened and unstiffened specimens for (a) 5% open area (b) 10% open area (c) 15% open area and (d) 20% open area

V. CONCLUSION

Replaceable link with reduced web section is developed and a design methods are derived. Non-linear FE analysis was also conducted in order to evaluate the plastic deformation capacity. From the analysis result, one can note that the reduced web link section satisfies the shear rotation limit recommended by AISC-2010 for shear link. The plastic rotation capacity decreases and fails to reach the limit for intermediate and flexural links. The effect of open areas on both hysteresis characteristics and deformation mode was presented and generally it is noted that as the percent of open area increase the plastic rotation capacity decreases.

As a summary, the results obtained from this study show that reduced link sections have a promising seismic performance especially for shear links to address the limitation in link-to-column connections in EBFs. In addition, the difficulties in the slab construction that arises due to section depth difference between collector beam and links made to control the plastic deformation at the link will be avoided because the reduced web section decreases the shear strength without decreasing the whole link depth.

ACKNOWLEDGMENT

This work was financially supported by research fund from Chosun University, 2016.

REFERENCES

- [1] C. W. Roeder, & E. P. Popov. 1977. Inelastic Behavior of Eccentrically Braced Steel Frames Under Cyclic Loadings, *Report No. UCB/EERC-77/18, Earthquake Engineering Research Center*, University of California at Berkeley.
- [2] A. Ghobarah, & T. Ramadan, 1994. Bolted link-column joints in eccentrically braced frames. *Engineering Structures*, 16(1): 33-41.
- [3] N. Balut & V. Gioncu 2003. Suggestion for an improved 'dog-bone' solution. *Proc. STESSA 2003. 9-12 June, Naples, Italy* 129-134.
- [4] Daniel Y. Abebe and Jaehyouk Choi. Finite element Investigation on Removable Shear Link with Perforated Web. *Proc. of the 2nd Australian Conference on Computational Mechanics 2015, 30 Nov-1 December, Brisbane, Australia*
- [5] Daniel Y. Abebe, Gyumyong Gwak¹, Meron W. Lemma¹, Jaehyouk Choi. Development and Analytical Evaluation of Removable Shear Link with Perforated Web. *Proc. of ICME-AM, 3-4 December, 2015, Kota Kinabalu, Sabah, Malaysia (Invited Paper)*

- [6] American Institute of Steel Construction (AISC). (2010). "Seismic provisions for structural steel buildings." ANSI/AISC 341-10, AISC, Chicago.
- [7] S. H. Chao, S. C. Goel, (2005). Performance based Seismic Design of EBF Using Target Drift and Yield Mechanism as Performance Criteria. A report on research sponsored by the American Institute of Steel Construction, Department of Civil and Environmental Engineering, The University of Michigan Ann Arbor, MI 48109-2125