

Condition Monitoring System of Mine Air Compressors Based on Wireless Sensor Network

Sheng Fu, Yinbo Gao, Hao Lin

Abstract—In the current mine air compressors monitoring system, there are some difficulties in the installation and maintenance because of the wired connection. To solve the problem, this paper introduces a new air compressors monitoring system based on ZigBee in which the monitoring parameters are transmitted wirelessly. The collecting devices are designed to form a cluster network to collect vibration, temperature, and pressure of air cylinders and other parameters. All these devices are battery-powered. Besides, the monitoring software in PC is developed using MFC. Experiments show that the designed wireless sensor network works well in the site environmental condition and the system is very convenient to be installed since the wireless connection. This monitoring system will have a wide application prospect in the upgrade of the old monitoring system of the air compressors.

Keywords—Condition monitoring, wireless sensor network, air compressor, ZigBee, data collecting.

I. INTRODUCTION

AIR compressor is one of the most important large scale fixed equipments in mine. It takes on the task of power supply for pneumatic machinery of the whole mine and for coal-whipper in main well. Air compressor is so critical equipment that once it goes wrong, normal proceeding of related production will be destroyed and even result in disastrous accidents [1]. Currently, air compressor monitoring systems in use are wired connection in which the sensors, collecting devices (such as PLC) and the display are connected through cables [2]. This method has high reliability, but it is difficult to install and maintain the system since the use of cable [3]. ZigBee is a wireless communication technology which has short distance, low power consumption and low cost. There are three kinds of devices in ZigBee: coordinator, router, and end device. The coordinator is responsible for the establishment and configuration of the network; the routers link groups of devices together and provide multi-hop communication across devices; the end devices have the function of joining and exiting the network, consisting of the sensors collecting data and communicate only with the routers and the coordinator. The powerful communication function makes it very suitable for applying in the field of WSN. At present, ZigBee has been applied in smart home, smart agriculture, environmental monitoring, industrial monitoring and other fields [3]-[5]. Considering the characteristics of ZigBee technology, we have

Sheng Fu, Yinbo Gao, Hao Lin is with the College of Mechanical Engineering and Applied Electronics Technology, Beijing University of Technology, Chaoyang District, Beijing, 100124, China (phone: +0-086-010-6739 6781; fax: 0-086-010- 6739 6781; e-mail: fusheng@bjut.edu.cn, gaoyinbo@emails.bjut.edu.cn, linhao@emails.bjut.edu.cn)

developed a new condition monitoring system of air compressor in mine.

II. OVERALL DESIGN OF THE MONITORING SYSTEM

In order to ensure the operation safety of air compressor, we should monitor many parameters, mainly including temperature, pressure, vibration, voltage, and current, which can reflect the status of the operation of air compressor. The details are shown in Table I.

TABLE I
 DETAIL MONITORING PARAMETERS

Monitoring parameters	Measure point arrangement	Sensor
I cylinder's exhaust pressure	Primary cylinder	Pressure sensor
II cylinder's exhaust pressure	Second cylinder	Pressure sensor
Lubricating oil pressure	Lubricating oil	Pressure sensor
Air tank pressure	Air tank	Pressure sensor
Cooling water pressure	Cooling water outlet	Pressure sensor
Vibration amplitude 1	Air compressor base	Vibration sensor
Vibration amplitude 2	Air compressor base	Vibration sensor
Vibration amplitude 3	Air compressor base	Vibration sensor
Vibration amplitude 4	Air compressor base	Vibration sensor
I cylinder's exhaust temperature	Primary cylinder	Temperature sensor
II cylinder's exhaust temperature	Second cylinder	Temperature sensor
Lubricating oil temperature	Lubricating oil	Temperature sensor
Air tank temperature	Air tank	Temperature sensor
Cooling water inlet temperature	Cooling water inlet	Temperature sensor
Cooling water outlet temperature	Cooling water outlet	Temperature sensor
Stator voltage	Electric cabinet in machine room	
Stator current	Electric cabinet in machine room	
Excitation voltage	Electric cabinet in machine room	Intelligent ammeter
Excitation current	Electric cabinet in machine room	
Power factor	Electric cabinet in machine room	

ZigBee network can be organized into a star network, mesh network or clustered network according to the application. In star network, all devices can only communicate with the coordinator, this structure is very simple and the router has no the function of routing. In mesh network, any two network routers can communicate directly as long as they are within each other's wireless radiation, but it is complex to build it and the information maintained by the node is too much. The clustered network can be seen as an extension of the star network, and its structure is shown in Fig. 1.

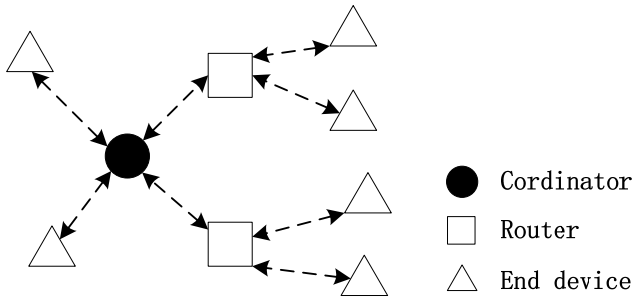

Fig. 1 Topological structure of the clustered network

The clustered network requires few resources and can achieve the function of routing and forwarding which expand the scope of network communication, so we design the WSN as a clustered network to monitor air compressors. In the

monitoring system, end devices are used to collect all the monitoring parameters and then send these collected data to the coordinator which will transfer the data to computer through the serial port. The routers are used to expand wireless transmission distance, which makes the wireless sensor network is able to adapt to more complex environment, thus expanding the application range of the monitoring system.

Fig. 2 shows the scheme of the entire air compressors monitoring system. In general, several sets of air compressors with the same capacity are installed in a machine room. Since the monitoring parameters are the same in each set, Fig. 2 shows only one set of end devices in the monitoring system. As can be seen, the coordinator, routers and all end devices consist of a distributed wireless sensor networks. The system is very flexible to use, we just add the appropriate end device when increasing monitoring parameters.

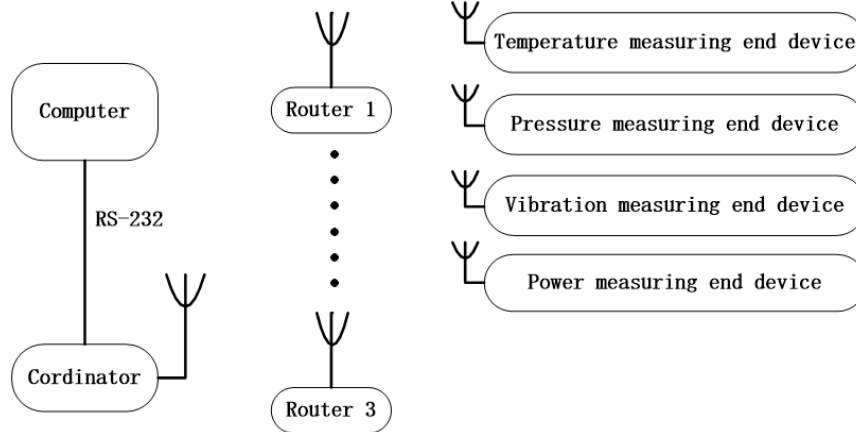

Fig. 2 Overall scheme of the air compressors monitoring system

III. DESIGN OF THE COLLECTING DEVICES

The routers and end devices are battery powered and the battery power supply can be maintained for six months to two years according to the trial run. ZigBee RF modules are used to design hardware for convenience. According to the practical requirements, we should design the following three kinds of collecting devices: temperature-measuring device, pressure measuring device, transmitter measuring device and electricity power measuring device. Since the data network rate of ZigBee is about 20~250 kbps and the total rate of the measured parameters is no more than 30 kbps, so it is sufficient to support the whole monitoring system.

Temperature measuring device is used to collect I and II cylinder's exhaust temperature and cooling water inlet and outlet temperature. Pressure measuring device is used to collect I and II cylinder's exhaust pressure, cooling water and lubricating oil pressure. Transmitter measuring device is used to collect the vibration of bearing. The block diagram of the collecting devices is shown in Fig. 3.

A. Design of Temperature Measuring Device

PT100 is used to measure temperature, and we choose the chip AD7792 to design the circuit of the temperature measuring device. AD7792 is very suitable for RTD measurements and it

can convert the resistance of PT100 into digital signal with only few peripheral devices. The temperature measuring device is shown in Fig. 4. Pressure measuring device is the same as it almost.

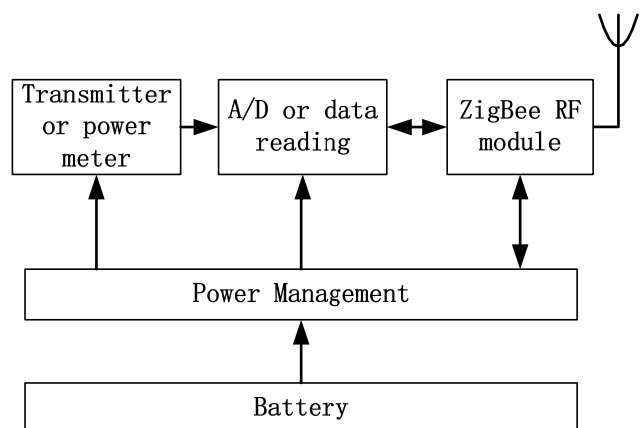

Fig. 3 The block diagram of the collecting devices

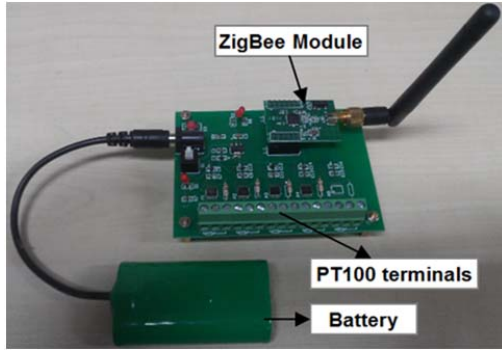

Fig. 4 Temperature measuring device

B. Design of Transmitter Measuring Device

The lowest supply voltage for transmitters used in the system is 12V, so we choose DC-DC devices to convert the voltage of the battery (7.2V) to this working voltage. Since the power of transmitters is too high for the battery that will cause inconvenience in the use, so we give the power to transmitter only at the moment it is collecting the signal, which will reduce the power of the device substantially. The output of the transmitters is current at 4-20mA, which is converted to voltage through a precision resistance. The transmitter measuring device is shown in Fig. 5.

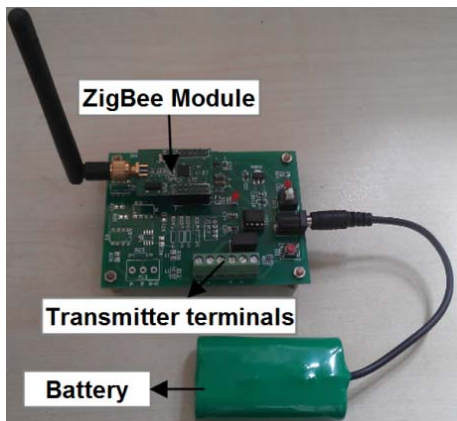

Fig. 5 Transmitter measuring device

C. Design of Electricity Power Measuring Device

A network multi-functional power meter with RS-485 interface and MODBUS-RTU protocol is used to measure the working voltage and current of the motor for convenience, so the main work to design the electricity power measuring device is to design the communication circuit and protocol. The power meter reading device is shown in Fig. 6.

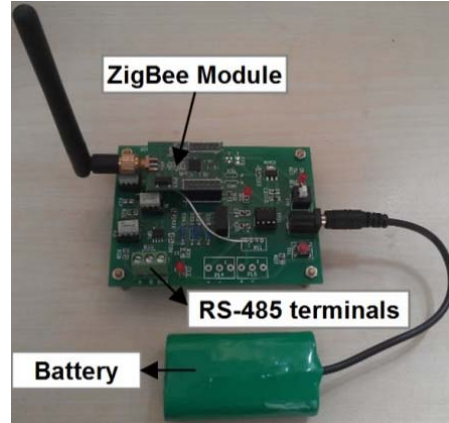

Fig. 6 Power meter reading device

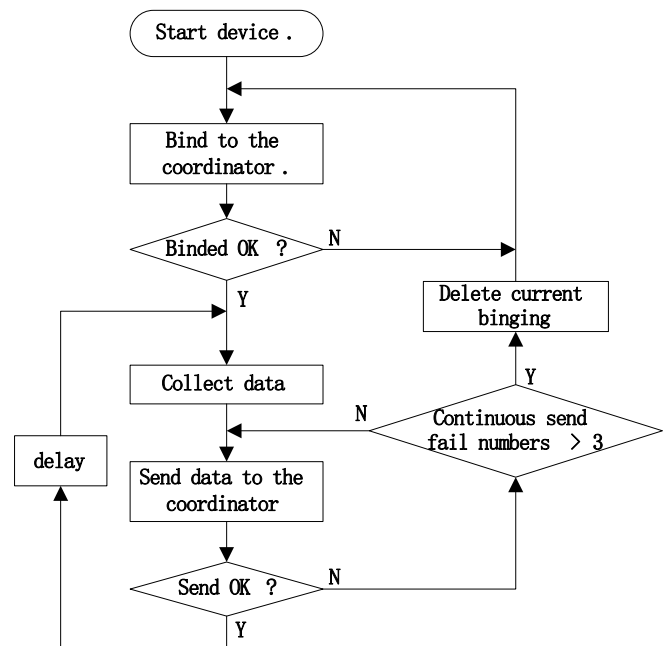

Fig. 7 The flow chart of program of end devices

V. MONITORING SOFTWARE DEVELOPMENT

The software is used to monitor all the monitoring parameters and alarming for abnormal behaviors and it is designed using MFC. The main functions of the software are as the following:

- 1) Real-time display of all the parameters;
- 2) Alarm when monitoring parameters are abnormal;
- 3) Save and inquiry the parameters;
- 4) Parameters settings, including alarm limits.

The coordinator sends the collected data to the computer while it receives them from the end devices. The monitoring software calculates each real parameter value after receiving the data, then display and save these parameters. The thresholds for monitored parameters can be adjusted by the actual situation. The parameters display interface of the monitoring software is shown in Fig. 8.

IV. DESIGN OF THE ZIGBEE PROGRAM

Program of ZigBee is designed based on Z-Stack. Communication between end devices and the coordinator takes biding mode. The flow chart of the collecting devices (end device) is shown in Fig. 7.

VI. EXPERIMENTS

We install the air compressors monitoring system in a mine, and Fig. 9 shows the practical installation of each ZigBee device.

The computer is in the monitor room. We put the coordinator

outside the room in order to avoid the disturbance from the wall. Four air compressors are outside of the room and the end devices over there need a router to send the collected data to the coordinator. The total system works well. All the collected data can be sent to the monitoring software in the one-day test.

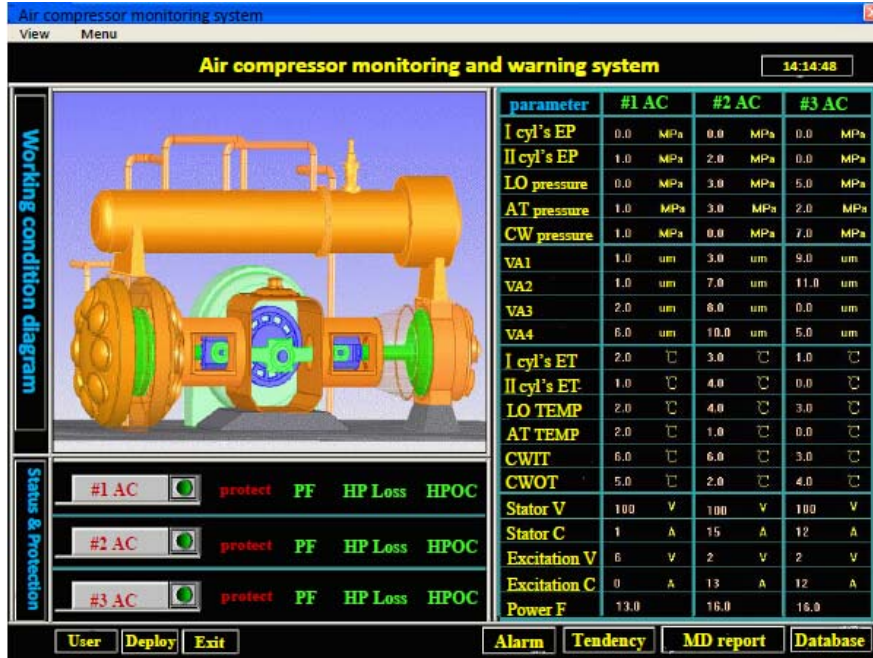

Fig. 8 Main measuring and monitoring interface for air compressor

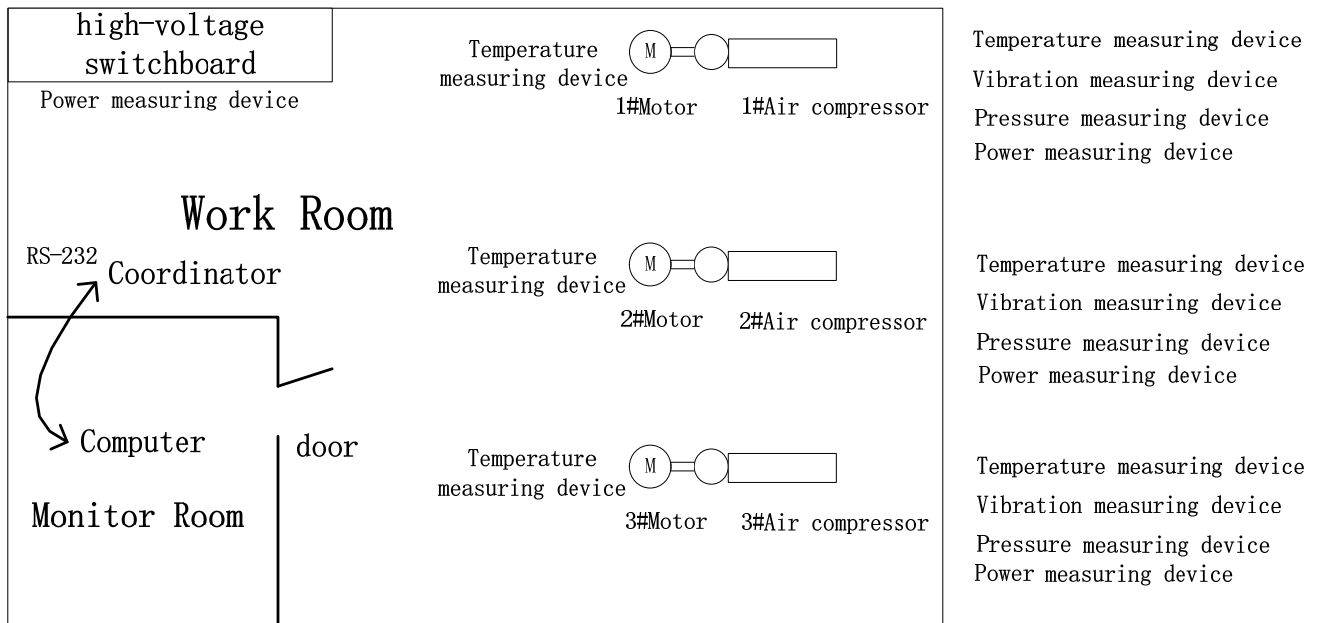

Fig. 9 Diagram of the installation of equipments

VII. CONCLUSION

A monitoring system for the mine air compressors is developed based on ZigBee in this paper. We have designed all the collecting devices according to the practical requirements, and developed the monitoring software based MFC. Field

experiment indicates that the system can be qualified for the monitoring task. This is a new kind of monitoring system for mine air compressors in which wireless sensor network displaces the cable. The system is very easy to install, and has a wide application prospect in the upgrade of the old monitoring

system of the mine air compressors.

ACKNOWLEDGMENT

The author gratefully acknowledges the support of K.C.Wong Education Foundation, Hong Kong.

REFERENCES

- [1] Sheng Fu, Jing Li, Yabin Zhang, "Fault Diagnosis System for Reciprocating Air Compressor Based on Support Vector Machine", *The 2009 International Workshop on Information Security and Application*, Qingdao, China, 2009, pp. 546-549.
- [2] Bao Chang-fu, Yang Chuan-qi, "Remote On-line Monitoring System for Air Compressor Used for Mine Based on Configuration Technology," *Coal Mine Machinery*, vol. 33, no. 2, pp. 236-238, 2012.
- [3] Sheng Fu, Hao Lin, "Design of Mine Ventilators Monitoring System Based on ZigBee", *Applied Mechanics and Materials*, v 385-386, pp. 626-630, 2013.
- [4] Wu Jian, Yuan Shen-fang, Shang Ying, et al, "Wireless Sensor Networks and Application Research Based on ZigBee Technology," *Measurement & Control Technology*, vol. 27, no. 1, pp. 13-16, 2008.
- [5] Jennifer Yick, Biswanath Mukherjee, Dipak Ghosal, "Wireless sensor network survey," *Computer Networks*, vol. 52, pp. 2292-2330, 2008.