

Examining the Effects of Production Method on Aluminium A356 Alloy and A356-10%SiC_p Composite for Hydro Turbine Bucket Application

Williams S. Ebhota, Freddie L. Inambao

TABLE I

SHP POTENTIAL IN SSA [3]

Regions in SSA	Available SHP potential (MW)	Installed capacity (MW)	Installed capacity (%)
Eastern Africa	6,262	209	3.3
Middle Africa	328	76	23.1
South Africa	384.5	43	11.2
West Africa	742.5	82	11.1

II. REVIEW

Loice and Ignatio investigated the effects of material, surface texture and fabrication methods on the efficiency of hydropower plant projects within an acceptable cost range. In their project, more electricity was generated at a reduced cost per unit kW. In their project, more electricity was generated at a reduced cost per unit kW. The study concluded that manufacturing of more efficient financially viable Pelton turbines for the micro hydro system (MHS) is possible [4]. A theoretical micro-hydroelectric plant design for off-grid applications was carried out to produce green power for remote farms or cottage. A prototype of the system was built to test the design [5].

A study on the modelling and validation of results empirically, using locally available materials in Kenya was carried out [6]. In the study, stress reduction of 14.2% was achieved by modifying the profile of the Pelton bucket. A recycled A356 aluminium alloy was found was to withstand the stress of 150 MPa, produced by the generated 5 kW of power [6]. A Pico Pelton turbine was designed and manufactured using chopped glass fibres reinforced epoxy matrix composite as the bucket material [7]. A 50,000 litre capacity storage tank in a 10 storey tower was used as a water source to operate the turbine. In the study, 1.5 kW was generated out of the 2.793 kW that it was theoretically designed for. In the design study of Nava and Siva, CATIA V5 design and modelling software were used to design an optimised Pelton turbine considering three materials in the analysis [8]. Efficiency and stress in relation to the number of buckets were studied in the work. In the three bucket materials selected (steel, cast iron and fibreglass reinforced plastic matrix), the study concluded that fibreglass reinforced plastic matrix shows exceptional performance compared to cast iron.

It is obvious that a lot of theoretical hydro turbine design works have been studied. However, only little is known when it comes to aluminium alloys and their composites for the fabrication of a Pelton turbine bucket. Considering the present

Abstract—This study investigates the use of centrifugal casting method to fabricate functionally graded aluminium A356 Alloy and A356-10%SiC_p composite for hydro turbine bucket application. The study includes the design and fabrication of a permanent mould. The mould was put into use and the buckets of A356 Alloy and A356-10%SiC_p composite were cast, cut and machined into specimens. Some specimens were given T6 heat treatment and the specimens were prepared for different examinations accordingly. The SiC_p particles were found to be more at inner periphery of the bucket. The maximum hardness of As-Cast A356 and A356-10%SiC_p composite was recorded at the inner periphery to be 60 BRN and 95BRN, respectively. And these values were appreciated to 98BRN and 122BRN for A356 alloy and A356-10%SiC_p composite, respectively. It was observed that the ultimate tensile stress and yield tensile stress prediction curves show the same trend.

Keywords—A356 alloy, A356-10%SiC_p composite, centrifugal casting, pelton bucket, turbine blade.

I. INTRODUCTION

IN this study, the focus is on property enhancement of A356 Aluminium alloy and A356-10%SiC_p composite, through manufacturing and heat treatment techniques for Pelton bucket application. The search for locally sourced materials for Small Hydropower (SHP) turbine components and systems production and their manufacturing technologies is very critical to energy sustainability in Sub-Saharan Africa (SSA). SHP technology domestication is the key to the perennial power problem in the region.

Capacities for turbine components and system design, material and manufacture should be enhanced through regional joint efforts, academic research, and an exchange programme with developed countries, etc. [1], [2]. The capacity building should be geared to increasing local participation and technology domestication in the region. SSA with a lot of SHP potentials as presented in Table I, needs to explore merits of switch-mode power supply (SMPS) for greater access to power [3].

A theoretical micro-hydroelectric plant design for off grid applications was carried out to produce a green power for remote farms or cottage.

Williams. S. Ebhota, PhD candidate, and Freddie Inambao, Associate professor, are with the University of KwaZulu-Natal, Durban, South Africa (phone: +27633840252; e-mail: willymoon2001@yahoo.com, inambao@ukzn.ac.za).

application of aluminium alloys and their composites, hypothetically, this study sees this group of materials versatile in Pelton turbine bucket application.

A. Application of A356 Alloy and A356-SiCp Composite Suitability for a Pelton Turbine Bucket

Previous studies of hydro turbine plants revealed that silt erosion affects the underwater components which include turbine blade greatly [3]. In some cases, water is stored in a reservoir or in a settling basin to be used when the need arises. Over a period of time, sediment with silt and hard abrasive sand as the components, settle in the reservoirs or basins. This problem must be taken care of with the use of sediment settling systems in power plants. However, a lot of unsettled sediment passes through turbines every year and turbine parts are exposed to severe erosion. This sediment should be prevented from passing through the turbine by incorporating the sediment settling systems in the power plant. However, there are still possibilities of unsettled sediment passing through the turbine and this occurrence causes serious erosion to the nozzle system and the turbine blade/bucket.

B. Functionally Graded Manufacturing Technique: Centrifugal Casting Technique

The centrifugal casting technique was chosen due to its mechanical and microstructural enhancing advantages. The process aids microstructure gradient and hardness in alloys even without reinforcement, and therefore, gives the material a better wear and corrosion resistance [9]. The mechanical properties of aluminium-silicon alloys are often improved by casting technology [10]. Quite often, hypoeutectic and near eutectic Al-Si alloys are applied when corrosion resistance and good castability are needed with a small amount of Mg and Cu for heat treatment enhancement. It has been revealed that centrifugal casting can increase: rupture strain by 160% and

rupture strength by 35%; young modulus by 18% and; fatigue life by 1.5% [11].

III. METHODOLOGY OF THE STUDY

The study is methodically divided into three: fabrication of the Pelton turbine bucket permanent mould; centrifugal casting of the bucket; and, characterisation of the Pelton turbine bucket materials.

A. Fabrication of Pelton Turbine Bucket

The fabrication of the Pelton turbine bucket has two stages: Production of permanent mould; and, centrifugal casting of the Pelton bucket. The 3D model of the bucket is shown in Fig. 1. In this study, the bucket was designed for a capacity of 18.45kW turbine power.

1) Production of Mould

The mould was designed with Solidworks software where the IGES files of the mould components were generated. The parts of the mould were machined according to the specifications in Initial Graphics Exchange Specification (IGES) files. The CAD of the mould as designed and produced are shown in Figs. 2 (a) and (b), respectively.

2) Mould Material

Oil Hardening Non-Shrinking Die Steel (OHNS) was used as the mould material and the components were heated treated before they were put to use. The chemical composition is shown in Table II. OHNS steel is a reliable material for gauging, blanking and cutting tools, as well as for hardness and elevated temperature applications [12]. A hardening temperature of 800 °C was used and a hardness of about 432 BHN of a 3,000 kgf standard force was recorded. The fabricated Pelton bucket mould components are presented in Fig. 3.

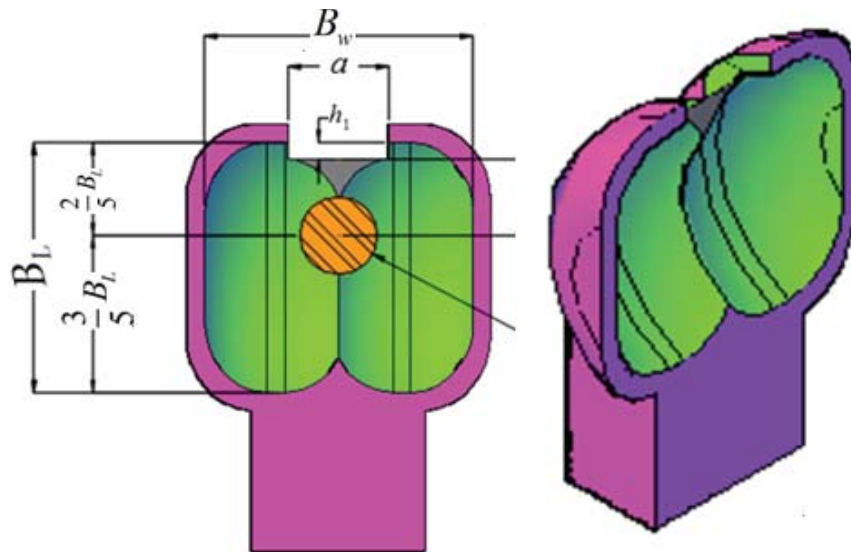
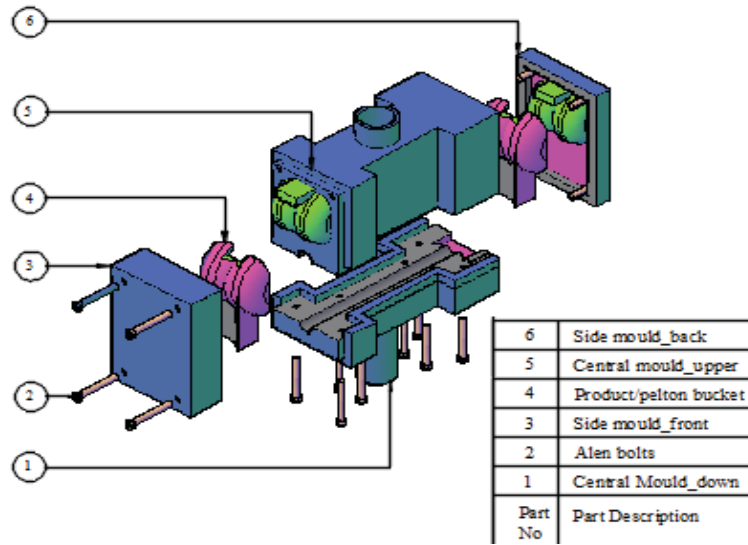
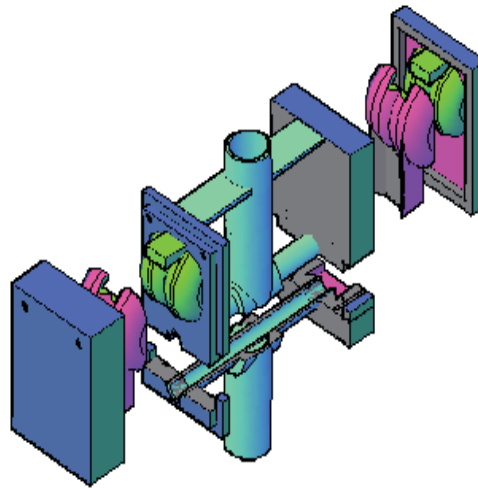

Fig. 1 The design parameters of a bucket



(a)



(b)

Fig. 2 (a) Exploded diagram of the Pelton bucket mould as designed, (b) Exploded diagram of the Pelton bucket mould as fabricated

TABLE II
CHEMICAL COMPOSITION OF THE OHNS MATERIAL USED FOR THE PELTON BUCKET MOULD

Element	C	Mn	Cr	W	V
%	0.95	1.1	0.6	0.6	0.2

B. Centrifugal Casting of Pelton Bucket

The chemical composition of A356 used is shown in Table III.

TABLE III
A356 ALLOY CHEMICAL COMPOSITION

Elements	Cu	Mg	Mn	Si	Fe	Ti	Zn	Al
%	0.25	0.30	0.35	7.5	0.35	0.05	0.10	91.10

1) Casting of A356 Alloy

Clay graphite crucible was used to process A356 alloy. Hexachloroethane was applied at 720 °C for degassing of the molten metal to prevent hydrogen entrapment. The molten

metal was superheated to (750 °C), which is above its liquidus temperature before pouring it into a spinning mould and a stationary rectangular mould for gravity casting. The Pelton bucket permanent mould was preheated to 300 °C and rotated at 1,500 rpm during pouring and solidification. The rotation was stopped five minutes after pouring.

2) Casting of A356-10%SiCp Composite

The same melting conditions for the A356 alloy, as stated above, were followed for the casting of the A356-10%SiC_p composite. The 25 µm SiC particle was preheated to 600 °C before inserting it into the A356 molten. The mixture was stirred with an electric motor driven impeller at a speed of 300 rpm. The particle feed rate to the molten metal is about 1 gm/s and the stirring continues for 15 minutes after the particles addition.

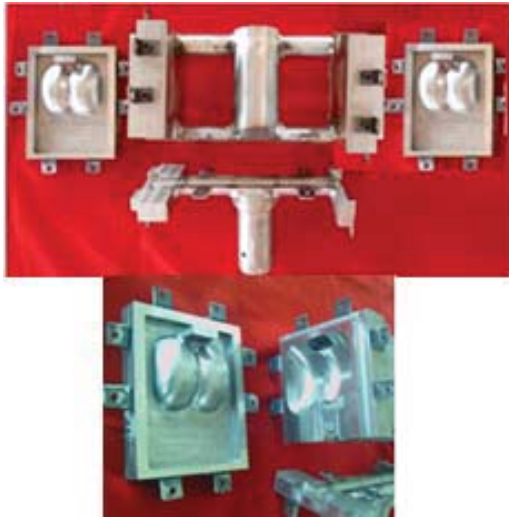

Fig. 3 The fabricated Pelton bucket mould components

In the mould configuration, it is designed to produce two castings in one operation. The arrangement is such that the faces are in the same direction as depicted in Fig. 4.

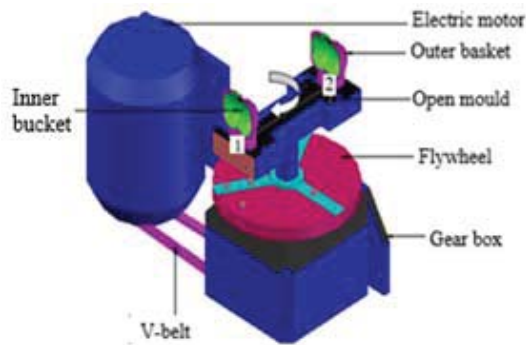

Fig. 4 Centrifugal casting machine with an opened mould in which the buckets are facing the same direction

C. Characterisation of Cast Bucket: Preparation of Test Specimen.

1) Microstructure Examination

The cast bucket of both materials under investigation was sliced at the middle, see Fig. 5 (a), into two parts and both halves were prepared for microstructural examination and hardness test. The samples for the microstructural view were polished using the following grits of polishing paper consecutively: 80, 100, 220, 400, 600 and 1,000. The paper polishing was followed by cloth polishing with 6 μm , 3 μm and 1 μm SiC_p particle paste. The polished sample was subjected to Leica optical microscopy for transverse viewing, as shown by the arrow in Fig. 5 (b).

2) Hardness Test

The second half of the sample was prepared for the Brinell hardness test and was only subjected to paper polishing grades of 80, 100, 220, 400, 600 and 1,000. The prepared sample for the hardness test is shown in Fig. 5. The polished sample was

subjected to 62.5 kgf load of the Tinius Olsen hardness testing machine transversely, as shown by the dots in Fig. 5 (b).

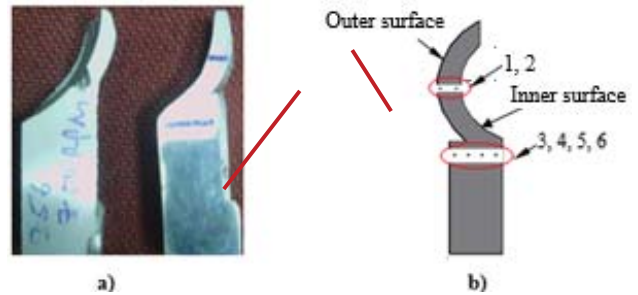

Fig. 5 (a) Samples for microstructural examination and for hardness test; (b) offset of the test sample's face

D. Heat Treatment

Solution heat treatment (T6) is the most widely used for the improvement of the combination of strength and ductility. The sample of A356 alloy was treated according to the T6 standard heat treatment of A356 alloy for hardness, strength and ductility enhancement. The specimen was heated to 540 °C and held for four hours and quenching in water of 65 °C temperature according to earlier studies [13], [14]. Artificial ageing was carried out at 165 °C for six hours and the process profile is shown in Fig. 6. The A356-10%SiC_p composite specimen was heated to 520 °C, held for eight hours and quenching in water at a temperature of 80 °C. The artificial ageing was done at 160 °C and held for 20 hours [15].

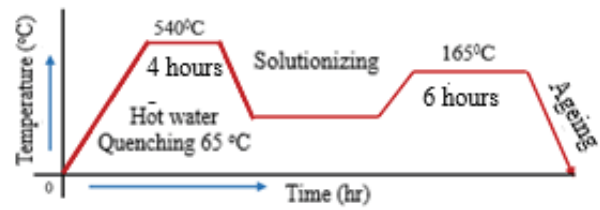

Fig. 6 Schematic of T6 Heat Treatment of A356 Alloy at 160 °C

The heat treatment process for A356-10%SiC_p is represented in Fig 7. Quenching was done according to B-917 ASTM standard, where the cooling was from 400 °C to 260 °C and the quenching delay time was less than 10 seconds. These precautionary steps ensure that there was no formation of a premature precipitate.

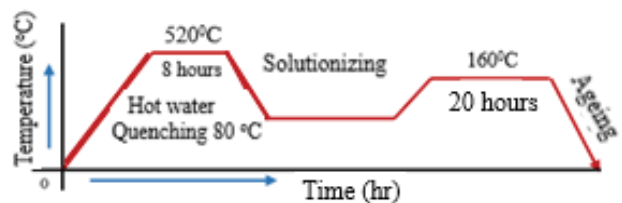

Fig. 7 Schematic of T6 Heat Treatment of A356-10%SiC composite profile

IV. RESULTS AND DISCUSSION

A. Casting of Pelton Bucket by Centrifugal Process

The defect caused by the centrifugal force on the cast bucket was a major challenge and the defect is shown Fig. 8 (a). In the study, several attempts were made by changing the process variables before a good cast was made. In centrifugal casting, there is the tendency of the surface of the cast, towards the centre of rotation, to form a parabola of revolution as depicted in the schematic in Fig. 8 (b).

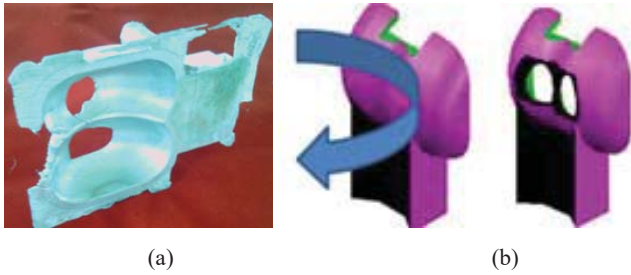

Fig. 8 (a) A defected cast caused by centrifuge; (b) schematic of effect of centrifuge

The curve formed is a function of these parameters: the rotational speed; the cast geometry; and, the pouring and

mould temperatures. In this work, the defect was corrected significantly by geometry and Fig. 9 shows the defect free Pelton bucket cast.



Fig. 9 The defect-free Pelton bucket cast

B. Microstructural Examination

The micrographs of buckets 1 and 2 in Fig. 10, shows the same gradient trend for both alloy and composite, but the trend in bucket 2 was in the opposite direction of bucket 1. For the purpose of bucket performance during operation, especially for wear resistance, bucket 1 in Fig. 10 is preferred. Figs. 10 and 11 show the pattern of the gradient in bucket 1 for the alloy and composite, respectively.

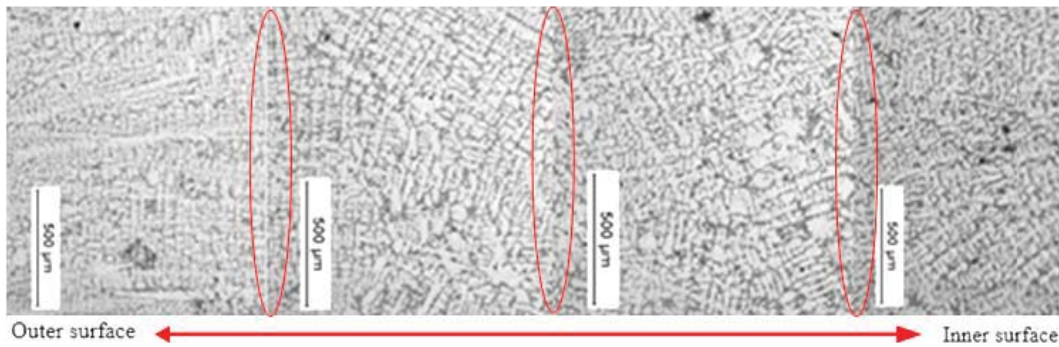

Fig. 10 The micrograph the gradient of cast bucket 1 of A356 alloy

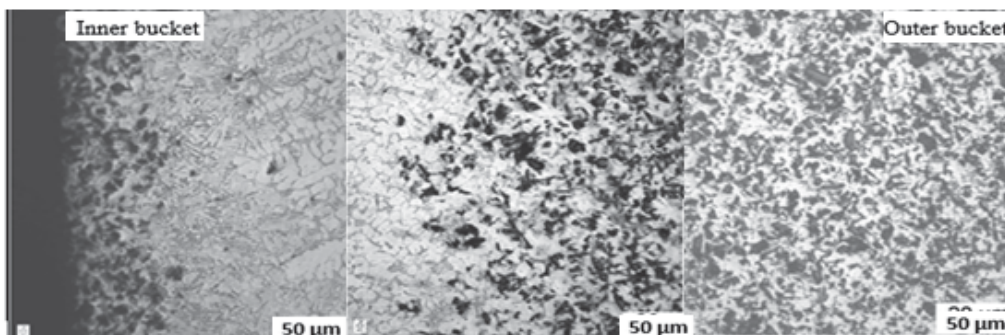

Fig. 11 The micrograph the gradient of cast bucket 1 of A356-10%SiC_p composite

C. Effect of T6 Heat Treatment and Centrifugal Casting Technique on Hardness

A356 alloy, which has Al-7.5%Si-0.3Mg is widely used in engineering industries including automotive, aerospace and military applications for high strength parts. It offers a good combination of mechanical properties such as castability,

strength, corrosion resistance and pressure tightness in both the permanent mould and sand cast condition. Despite these attributes, in most cases, A356 alloy is not used as cast, as the presence of eutectic silicon causes it to perform below optimal value. Generally, the mechanical properties of aluminium alloys and composites are reduced by coarse grain, cavities

and needle shape eutectic silicon. Modification and refinement improves the mechanical properties such as tensile strength, impact strength, wear resistance and hardness significantly [16], [17]. Very fast solidification rate, heat and chemical treatments are the three basic methods of enhancing the properties. In chemical treatment, a small amount of sodium is added to the melt and this changes the eutectic silicon phase morphology from coarse acicular to fine fibrous. This process enhances the mechanical properties of aluminium alloys [18]-[20].

3) Centrifugal Casting

The large dendritic cells, large flakes of silicon and large inter-dendrite arm spacing of α -aluminium dendrites that are produced by a low solidification rate, need to be reduced. While a high solidification rate gives small dendritic cells, small inter-dendrite arm spacing and small flakes of silicon and morphologically changed from acicular to fibrous [21]. Centrifugal casting affects the rate of solidification and consequently enhances the quality of casting.

The rate at which centrifuge affects the microstructure of an alloy depends on the speed. Studies have shown that the optimum centrifugal is between 1,200-1,500 rpm [21], [22]. At a speed of 1,500 rpm, the microstructure of the bucket experiences the following: the transformation of large primary silicon into needle-shaped eutectic silicon in the inner; long needle-shaped eutectic silicon is converted into fine primary silicon at the outer; and, there is the formation of fine grain. The transformations and the high rate of solidification enhanced the hardness value of both A356 alloy and A356-10%SiC_p composite. The maximum hardness of 60BRN was recorded at 5 mm from the surface of the inner part of the bucket and 55 BRN was recorded in the outer region.

4) Heat Treatment

The heat treatment of A356 can be classified into three, based on soaking temperatures: Soaking at a high temperature of 560 °C [13], [14]; soaking temperature slightly below the eutectic temperature at 540 °C [23]-[25]; and, the soaking temperature at 500 °C. Quite often, hypoeutectic and near eutectic Al-Si alloys are applied when corrosion resistance and good castability are needed and with a small quantity of Mg and Cu for heat treatment enhancement. In certain heat treatment conditions, as in the case of the T6 treatment of A356, precipitation of Mg₂Si and that of silicon occur [18].

The hardness of both the alloy and composite samples increased appreciably after the heat treatment. Maximum hardness (98 and 122 BRN for the alloy and composite, respectively) was recorded at about 5 mm from the inner face in both samples. Lesser hardness values were recorded at about 2 mm from the inner surface in all the samples. This is due to the rapid solidification at the inner surface periphery, facilitated by cooling caused by mould rotation. The hardness increase recorded is due to supersaturate solid solution production that occurred during the soaking of A356 alloy at 540 °C for four hours. This process causes the dissolution of hardening elements (Mg₂Si) in the matrix into globular

primary α -Al, spheroidisation of eutectic silicon and casting homogenisation [3]. Fig. 12 shows the hardness trends in the samples.

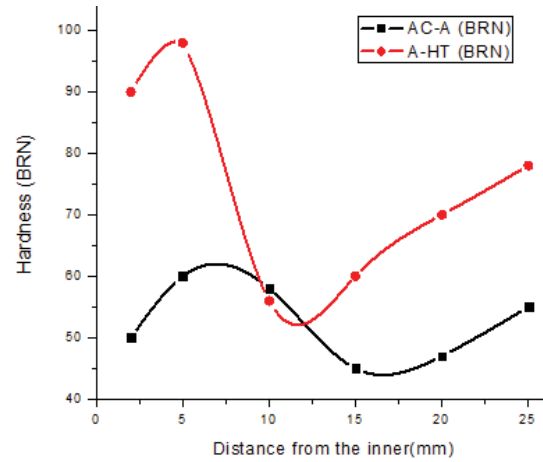

(a)

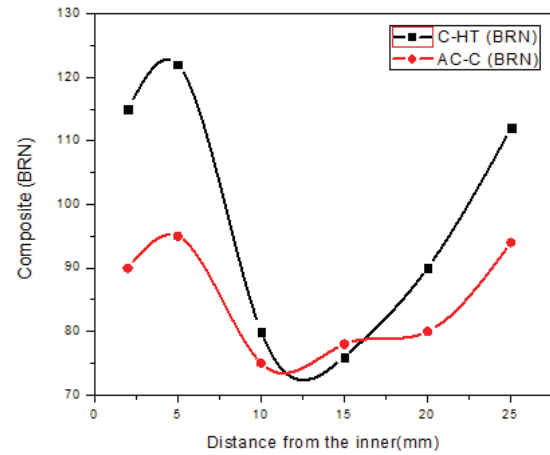

(b)

Fig. 12 Brinell micro-hardness plot for a) A356 alloy as-cast and heat treated; and, b) A356-10%SiC_p as-cast and heat treated where AC = as-cast A356 alloy; A-HT = A356 alloy heat treated; AC-C = As-cast A356-10%SiC composite; C-HT = A356-10%SiC composite heat treated.

The dissolution of Mg₂Si, Spheroidisation and homogenisation of eutectic silicon in A356 happens within five minutes of soaking at 540 °C.

5) Yield Strength (YS) and Ultimate Tensile Strength (UTS) Predictions

The strength of A356-T6 and A356-SiC-T6 can be predicted using an equation in a previous work [26]:

$$YS = 3.03 \times VHN \times (0.055)^n \quad (1)$$

where YS - yield strength, VHN – Vickers hardness number, and n - strain hardening exponent (0.091). The YS and UTS prediction curves for the samples are shown in Figs. 13-15.

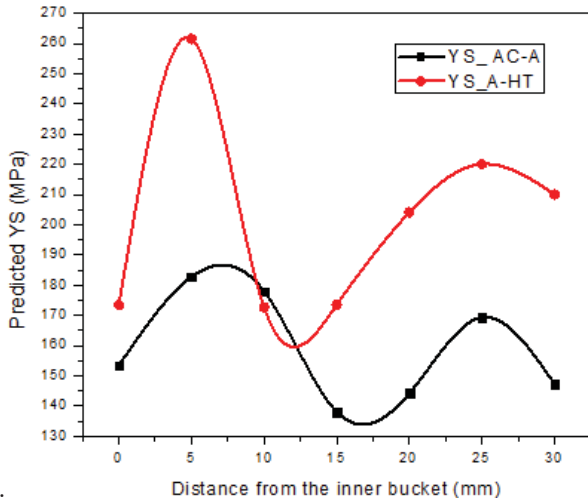

(a)

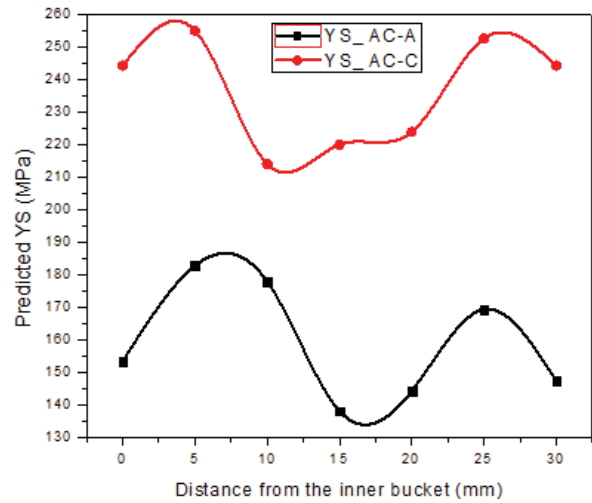

(a)

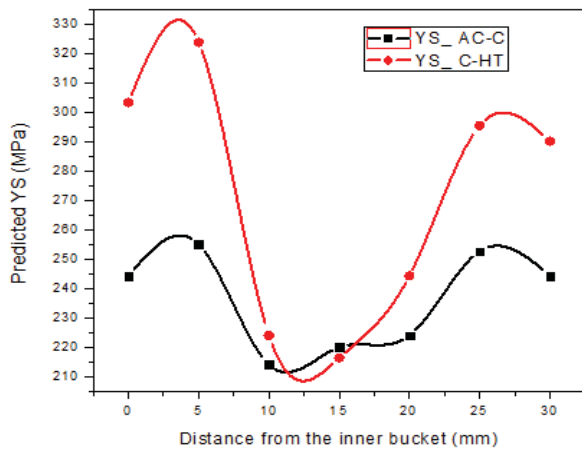

(b)

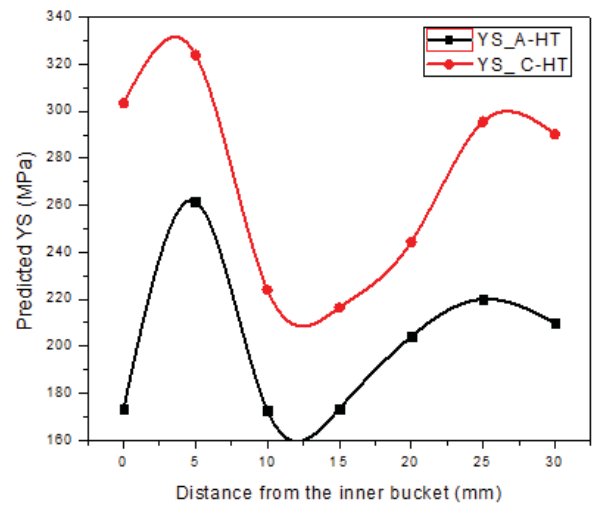

(b)

Fig. 13 Yield strength prediction of a) A356 as cast (YS_AC-A) and heat treated (YS_AC-HT) and b) A356-SiC_p as cast (YS_A-C) and heat treated (YS_C-HT)

Fig. 14 Yield strength prediction of a) A356 as cast (YS_AC-A) and A356-SiC_p as cast (YS_A-C) and b) A356 heat treated (YS_A-HT) and A356-SiC_p heat treated (YS_C-HT)

Again, the YS-UTS ratio can be predicted in terms of n , using (2) and (3):

$$YS_{0.2\%} / UTS = \frac{[(0.002)^n (exp n)]}{(n)^n} \quad (2)$$

$$UTS = \frac{YS_{0.2\%} n^n}{[(0.002)^n (exp n)]} \quad (3)$$

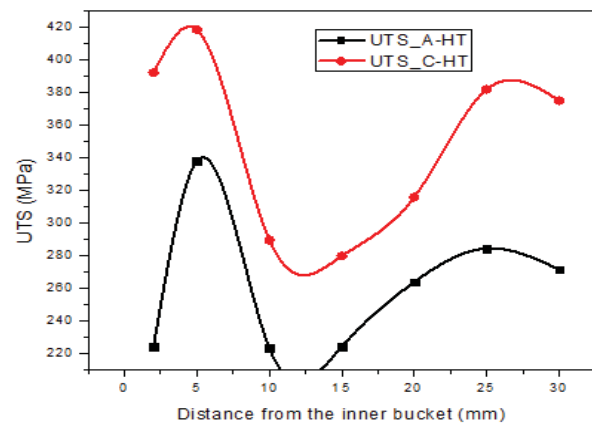

Fig. 15 UTS prediction of heat treated a) A356 (UTS_A-HT) and A356-SiC_p (UTS_C-HT)

From Figs. 13-15, it was observed that the YS and UTS, appreciated greatly across the surface for both A356 alloy and A356-SiC_p composites after heat treatment.

V. PROTECTIVE COATING OF PELTON BUCKET

Despite the wear and corrosion resistance of the A356 alloy and A356-SiC_p composite, they are still very much susceptible to seawater corrosion and silt erosion over time. For better operation performance and lifespan, coating the bucket's inner surface with tougher and hardened material is recommended. Coating the turbine with ceramic is common and effective due to the provision of the following protective service to the turbine surface: Wear and corrosion protection, impingement protection, silt erosion protection and surface hardness improvement. This study recommends a ceramic coating of Al₂O₃ implanted Fe micrograins, and microarc oxidation (MAO) or plasma electrolytic oxidation (PEO).

VI. CONCLUSION

This study concludes that:

- i. To genuinely turn around the perennial power issues in SSA, power should be generated from the abundant small hydro potentials with the application of indigenous technology and materials.
- ii. Use of centrifugal casting method and heat treatment improved the mechanical properties of the A356 alloy and A356-SiC_p composite, making them more suitable for Pelton bucket application.
- iii. Heat treated A356 alloy and A356-SiC_p composite, will be suitable for turbine materials for a water storage turbine system. This is due to the minimal percentage of silt in the stored water and the enhanced corrosion and wear resistance properties of the materials.
- iv. To further improve the life span of the bucket, hard surface coating should be applied

ACKNOWLEDGEMENTS

The authors hereby acknowledge the Centre for Engineering Postgraduate Studies, management and staff of the University of KwaZulu-Natal.

REFERENCES

- [1] W. S. Ebhota, A. C. Eloka-Eboka, and F. L. Inambao, "Energy sustainability through domestication of energy technologies in third world countries in Africa," in *Industrial and Commercial Use of Energy (ICUE), 2014 International Conference on the "Energy efficiency in buildings"*. 2014, pp. 1-7.
- [2] W. S. Ebhota & F. L. Inambao (2016) Electricity insufficiency in Africa: A product of inadequate manufacturing capacity, *African Journal of Science, Technology, Innovation and Development*, vol. 8, pp. 197-204.
- [3] H. Liu, D. Masera, and L. Esser, "World Hydropower Development Report 2013.," United Nation Industrial Development Organisation (UNIDO) and Intertional Centre on Small Hydropower (ICSHP), 2013.
- [4] G. Loice and M. Ignatio, "Efficiency Improvement of Pelton Wheel and Crossflow Turbines in Micro-Hydro Power Plants: Case Study," *International Journal of Engineering and Computer Science* vol. 2, pp. 416-432, 2013.
- [5] B. William, S. Vasu, and S. Manjot, "Green Mechatronics Project: Pelton Wheel Driven Micro-Hydro Plant," Mechanical Engineering University of Ottawa, 2010.

- [6] R. N. Mbiu¹, S. M. Maranga, and H. Ndiritu, "Performance of Aluminium A356 Alloy Based Buckets Towards Bending Forces on Pelton Turbines," in *Sustainable Research and Innovation (SRI) Conference*, Nairobi, Kenya, 2015, pp. 134-138.
- [7] I. A. K. M. Khabirul, B. Sahnewaz, and A. C. Farooque, "Advanced Composite Pelton Wheel Design and Study its Performance for Pico/Micro Hydro Power Plant Application," *International Journal of Engineering and Innovative Technology (IJEIT)*, vol. 2, pp. 126-132, 2013.
- [8] N. I. R. Nava and T. S. Prasad, "Design and Static Analysis of Pelton Turbine Bucket " *International Journal of Science Technology and Management*, vol. 4, pp. 19-25, 2015.
- [9] A. C. Vieira, P. D. Sequeira, J. R. Gomes, and L. A. Rocha, "Dry Sliding Wear of Al Alloy/SiC_p Functionally Graded Composites: Influence of Processing Conditions," *Wear* vol. 267 pp. 585-592., 2009.
- [10] *Casting Metal handbook*, 9th ed. vol. 15: ASM International, 1997.
- [11] G. Chirita, I. Stefanescu, D. Cruz, D. Soares, and F. S. Silva, "Sensitivity of Different Al-Si Alloys to Centrifugal Casting Effect," *Materials and Design* vol. 31 pp. 2867-2877, 2010.
- [12] SAAJ. (2014, 23/03/2016). *Die Steel Grade OHNS*. Available: http://saaisteel.com/?page_id=1055.
- [13] D. L. Zhang, L. Zheng, and D. H. StJohn, "Effect of Solution Treatment Temperature on Tensile Properties of Al-7Si-0.3 (wt-%) Alloy," *Materials Science and Technology*, vol. 14, pp. 619-625, 1998.
- [14] S. Shivkumar, S. Ricci, B. Steenhoff, and D. Apelian, "An Experimental Study to Optimize the Heat Treatment of A356 alloy " *American Foundry Society Transaction*, vol. 97, pp. 791-810., 1989.
- [15] M. Drouzy, S. Jacob, and M. Richard, "Interpretation of Tensile Results by Means of Quality Index and Probable Yield Strength," *AFS International Cast Metals Research Journal*, vol. 5, pp. 43-50, 1980.
- [16] K. G. Basavakumar, P. G. Mukunda, and M. Chakraborty, "Impact Toughness in Al -12Si and Al-12Si-3Cu Cast Alloys- Part - I: Effect of Process Variables and Microstructure," *International Journal of Impact Engineering*, vol. 25, pp. 199-205, 2008.
- [17] T. M. Chandrashekharaiah and S. A. Kori, "Effect of Grain Refinement and Modification on the Dry Sliding Wear Behaviour of Eutectic Al-Si Alloys," *Tribology International*, vol. 42, pp. 59-65, 2009.
- [18] F. H. P. Juan, "Heat Treatment and Precipitation in A356 Aluminum Alloy," Doctor of Philosophy, Mining, Metals and Materials Engineering, McGill University, Montreal, Canada, 2003.
- [19] L. Heusler and W. Schneider, "Recent Investigations of Influence of P on Na and Sr Modification of Al-Si Alloys " *American Foundry Society Transaction*, vol. 97, pp. 915-921, 1997.
- [20] B. C. a. J. E. Gruzleski., "Mechanical Properties of A356.0 Alloys Modified with Pure Strontium " *American Foundry Society Transaction*, pp. 453-464, 1982.
- [21] B. P. Vikramkumar, "Investigations on the Properties of Al-Si Alloy Synthesized by Centrifugal Casting Process," Metallurgical Engineering, Ganpat Uniuersity, Kherva, India, 2014.
- [22] A. S. Rao, S. T. Mahantesh, and S. R. Shrikantha, "Understanding Melt Flow Behavior for Al-Si Alloys Processed Through Vertical Centrifugal Casting," *Materials and Manufacturing Processes*, vol. 30, pp. 1305-1311, 2015.
- [23] M. Ishak, A. Amir, and A. Hadi, "Effect of Solution Treatment Temperature on Microstructure and Mechanical Properties of A356 Alloy," presented at the International Conference on Mechanical Engineering Research (ICMER2013), Bukit Gambang Resort City, Kuantan, Pahang, Malaysia, 2013.
- [24] B. A. Dewhirst, "Optimisation of the Heat Treatment of Semi-Solid Processed A356 Aluminum Alloy," Masters Worcester Polytechnic Institute, 2005.
- [25] M. Rosso and G. M. Actis, "Optimisation of Heat Treatment Cycles for Automotive Parts Produced by Rheocasting Process.," *Solid State Phenom.*, vol. 116-117, pp. 505-8, 2006.
- [26] M. K. Padhy and R. P. Saini, "Effect of Size and Concentration of Silt Particles on Erosion of Pelton Turbine Buckets," *Energy* vol. 34, pp. 1477-1483, 2009.



Ebhota Williams S. received Bachelor of Engineering degree from Ambrose Alli University, Ekpoma, Nigeria and Master of Engineering degree in Mechanical Engineering from Nnamdi Azikiwe, University, Awka, Nigeria. He is specialised in Design, Material, Manufacturing, and Energy Studies. He has worked as a

research and production engineer from 2002 to 2014 in National Engineering Design Development Institute, Nnewi, Nigeria. Presently, his is a doctoral candidate in the Discipline of Mechanical Engineering, Howard College, University of KwaZulu-Natal, Durban, South Africa.



Freddie L. Inambao holds a Master of Science (M. Sc) and Ph. D in Mechanical Engineering with specialisation in Thermodynamics and Internal Combustion Engines from Volgograd Polytechnic Institute, Russia. He has lectured at several universities in Southern Africa including the University of Zambia, University of Botswana, the University of Durban-Westville (before the merger with the University of Natal) and currently a

Senior Lecturer in the Discipline of Mechanical Engineering of the University of KwaZulu-Natal, Howard College, Durban, South Africa.