

Multi-Objective Optimization of a Solar-Powered Triple-Effect Absorption Chiller for Air-Conditioning Applications

Ali Shirazi, Robert A. Taylor, Stephen D. White, Graham L. Morrison

Abstract—In this paper, a detailed simulation model of a solar-powered triple-effect LiBr–H₂O absorption chiller is developed to supply both cooling and heating demand of a large-scale building, aiming to reduce the fossil fuel consumption and greenhouse gas emissions in building sector. TRNSYS 17 is used to simulate the performance of the system over a typical year. A combined energetic-economic-environmental analysis is conducted to determine the system annual primary energy consumption and the total cost, which are considered as two conflicting objectives. A multi-objective optimization of the system is performed using a genetic algorithm to minimize these objectives simultaneously. The optimization results show that the final optimal design of the proposed plant has a solar fraction of 72% and leads to an annual primary energy saving of 0.69 GWh and annual CO₂ emissions reduction of ~166 tonnes, as compared to a conventional HVAC system. The economics of this design, however, is not appealing without public funding, which is often the case for many renewable energy systems. The results show that a good funding policy is required in order for these technologies to achieve satisfactory payback periods within the lifetime of the plant.

Keywords—Economic, environmental, multi-objective optimization, solar air-conditioning, triple-effect absorption chiller.

I. INTRODUCTION

THE primary energy use in buildings has been dominated by conventional air-conditioning systems which contribute to about 40% of the greenhouse gas emissions in building sector [1], [2]. With the rising demand for indoor comfort, rising concerns about climate change and depletion of fossil fuel resources, finding an environmentally friendly and energy-efficient alternative to conventional air-conditioning systems is necessary [3]. Solar heating and cooling (SHC) absorption chillers are considered as one promising alternative to conventional air-conditioning systems since much of the technology has already been proven at commercial scales. Absorption chillers are mainly categorized by the number of effects which refer to the number of times the high temperature heat source is used by the chiller to produce cooling. Moving toward a higher effect cycle leads to higher chiller COPs, but in turn requires higher driving

temperature. Single-effect chillers operate in the temperature range of 80 °C to 100 °C, achieving thermal COPs of up to 0.7-0.8 [4]. Double-effect chillers can achieve higher COPs up to 1.4, but require significantly higher driving temperatures of around 180 °C [5]. Having three cascading generators, triple-effect absorption chillers can produce cooling at even higher COPs of around 1.8, but require a very high-temperature heat source of 210-240 °C [6]. Such temperatures can be supplied by using high temperature concentrating collectors such as parabolic troughs.

Most of solar absorption chillers installed around the world are based on single-effect chillers and non-concentrating flat plate or evacuated tube collectors [7]–[10]. The major disadvantage to single-effect chillers is its low COP, which leads to a large collector area to supply the thermal heat demand of the chiller. Combining high-temperature solar thermal collectors and multi-effect absorption chillers can be more energy-efficient due to the higher COP of these chillers, resulting in less solar thermal energy and potentially less collector area to supply a given amount of cooling [11], [12]. Cabrera et al. [13] carried out a comprehensive literature review on the use of parabolic trough collectors (PTCs) in solar air-conditioning applications and summarized the existing experiences and realizations for the potential application of these collectors to drive double-effect absorption chillers. They found that the yearly installation rate of this type of systems is still low, but according to the market potential, this rate is expected to increase in the near future. The potential of triple-effect absorption systems coupled with high-temperature solar thermal collectors have been studied by a few researchers [14], [15]. Although triple-effect absorption chillers have been around for a while, there has been no system-level modeling and optimization of these chillers coupled with high-temperature concentrating solar thermal collectors for *air-conditioning* applications. Motivated by this gap, this paper presents a detailed multi-objective optimization of a SHC triple-effect LiBr–H₂O absorption chiller, aiming to determine the optimal performance of the system from energetic, economic, and environmental perspective simultaneously. A complete dynamic simulation model of this system was developed in TRNSYS 17 [16], where its energy performance was evaluated. A detailed economic analysis was conducted to calculate the total levelized cost of the plant, including the capital cost, operating and maintenance cost, the fuel cost, and a penalty cost for CO₂ emissions. A multi-objective optimization approach using a genetic algorithm was

A. Shirazi is with The University of New South Wales, Sydney, Australia (phone: +61-413077896; e-mail: a.shirazi@unsw.edu.au).

R. A. Taylor and G. L. Morrison are with The University of New South Wales, Sydney, Australia (e-mail: robert.taylor@unsw.edu.au, g.morrison@unsw.edu.au).

S. D. White is with Commonwealth Scientific and Industrial Research Organization (CSIRO) Energy Centre, Newcastle, Australia (e-mail: Stephen.D.White@csiro.au).

employed through coupling TRNSYS and MATLAB to determine the optimal design of the system. The optimization objectives were the primary energy consumption and the total levelized cost of the system, which were both minimized. Finally, a LINMAP decision-making method was used to determine the final optimal design of the system, which was compared to that of a reference conventional system.

II. SYSTEM DESCRIPTION

In this paper, PTCs were coupled with a triple-effect LiBr-H₂O absorption chiller in order to supply both cooling and heating demand of a large reference building. This improves the economics of the plant compared to those producing either chilled or hot water alone. It should be noted that PTCs are the only solar thermal collectors available on the market, which are capable of delivering temperatures greater than 210 °C with an acceptable thermal efficiency. As illustrated in Fig. 1, a gas burner is employed as the backup system, delivering heat to the chiller when solar-driven energy is not sufficient. The rated cooling capacity of the absorption chiller is selected in order to satisfy the maximum cooling load of the building.

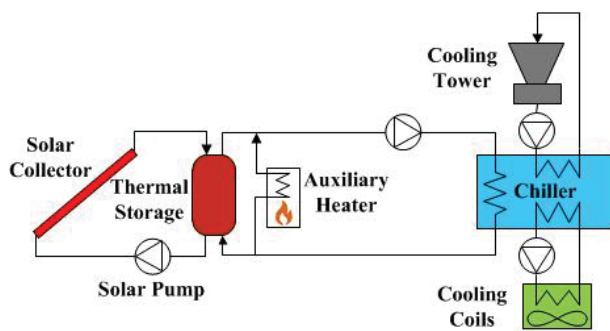

Fig. 1 A generic layout of a solar-assisted absorption chiller with a gas-fired backup

The incident solar radiation absorbed by the collector arrays increases the temperature of the stratified hot water storage tank. A feedback controller is used to adjust the pump flow rate to achieve a fixed set-point temperature at the collector outlet. A pressure relief valve is used to limit the fluid outlet temperature to the maximum allowable value specified by the user as an input to the model. During cooling periods when the temperature at the top 75% of the storage tank is above the chiller's required hot water temperature, only the solar heat source is used to drive the absorption chiller to produce chilled water for space cooling. Once the temperature at the top of the tank drops below the required value at the chiller's generator, the gas burner is switched on to supply the entire cooling demand of the building. The chilled water produced by the chiller is delivered to the cooling fan coil using a fixed flow pump to satisfy the required building cooling load. The chiller is also connected to a cooling tower loop to remove heat from its absorber and condenser into the ambient. During heating periods, the hot water stored in the tank is directly delivered to the heating fan coil unit to cover the building heating load. Similarly, if the temperature of the storage tank drops below

the required temperature for the distribution system, the gas burner is turned on to satisfy the entire heating load.

A conventional air-conditioning system, consisting of a vapor compression mechanical chiller and a gas-fired heater, is considered here as a reference system to compare the performance of the proposed solar triple-effect absorption chiller from energetic, economic, and environmental viewpoints.

III. SYSTEM SIMULATION

The proposed SHC absorption chiller system was modeled in TRNSYS 17 [16], which is commonly used for simulation of transient thermal systems. The following details the mathematical model of the key system components.

A. Parabolic Trough Solar Collector

The useful heat collected from a PTC module ($\dot{Q}_{u,SC}$) can be calculated as [17]:

$$\dot{Q}_{u,SC} = \dot{m}_w c_{p,w} (T_{SC,out} - T_{SC,in}) = A_a \left[F'(\tau\alpha)_n K_{\theta b}(\theta) G_b - \frac{F'U_L}{CR_{SC}} (T_{avg} - T_a) \right] \quad (1)$$

$$F'U_L = c_1 + c_2 (T_{avg} - T_a) \quad (2)$$

where $F'(\tau\alpha)_n$ is the collector zero loss efficiency at normal incidence, $K_{\theta b}(\theta)$ and G_b denote the incidence angle modifier for beam radiation and the solar beam irradiance on the collector surface, F' and U_L are the collector efficiency factor and overall heat loss coefficient, and A_a and CR_{SC} are the collector aperture area and concentration ratio. The terms c_1 and c_2 are the first and second order heat loss coefficients, and T_{avg} and T_a are the average temperature of the collector working fluid and ambient temperature, respectively. A new type (labelled 'Type 237') was developed to simulate the performance of the PTC module in TRNSYS environment. The design parameters used for this type are representative of NEP Polytrough 1800 [18], which are summarized in Table I.

B. Hot Water Storage Tank

A TRNSYS 'Type534' TESS model [19] was used to simulate the performance of the stratified storage tank in this study. The tank was assumed to have 10 thermal stratification nodes, an aspect ratio of 3.5 [20], and a heat loss coefficient of 0.833W/m²K. More details about the mathematical model of the tank can be found in TRNSYS TESS Library documentation [19].

C. Solar-Gas Heat Source Controller

Combining the mathematical equations of 'Type 6' (an auxiliary gas-fired heater) and 'Type 11 (a tee-piece)' from the TRNSYS standard library with some control-logic necessary to switch between solar and gas modes, a new TRNSYS type (labelled 'Type 223') was developed to model the solar-gas heat source component. The outlet temperature of the heater

can be determined by [21]:

$$T_{AH,out} = T_{AH,in} + \frac{\dot{Q}_{AH} - \dot{Q}_{loss,AH}}{\dot{m}_{w,AH} c_{p,w}} \quad (3)$$

where \dot{Q}_{AH} and $\dot{Q}_{loss,AH}$ are the burner heating rate and heat losses through the burner, respectively.

TABLE I
 PERFORMANCE PARAMETERS OF THE PTC USED IN THIS STUDY [18]

Parameter	Unit	Value
Aperture area	m ²	18.45
Max operating pressure	bar	40
Test flow rate	L/h m ²	75.9
Collector azimuth	°	0
Concentration ratio	-	54
$F'(\tau\alpha)_n$	-	0.689
c_1	W/m ² K	0.36
c_2	W/m ² K ²	0.0011

D. Absorption Chiller

The triple-effect absorption chiller was modeled using the adapted characteristic equation method capable of predicting the chiller's performance by using two algebraic equations to calculate the chiller cooling capacity and the driving heat input as functions of a term called $\Delta\Delta T'$ [22]. $\Delta\Delta T'$ can be expressed as:

$$\Delta\Delta T' = T_G + a \times T_{AC} + e \times T_E \quad (4)$$

where T_G , T_{AC} , and T_E are the average temperature of the external heat carrier fluids at the generator, absorber-condenser, and evaporator. The characteristic equations for the cooling capacity and driving heat of the chiller are defined as:

$$\dot{Q}_E = s_E \Delta\Delta T' + r_E \quad (5)$$

$$\dot{Q}_G = s_G \Delta\Delta T' + r_G \quad (6)$$

The characteristic coefficients (i.e. a , e , s_E , r_E , s_G , and r_G) are determined using multiple linear regression algorithms applied to a set of performance data points given by the chiller manufacturer. The heat removal rate from the absorber and condenser and the chiller COP can be determined by:

$$\dot{Q}_{AC} = \dot{Q}_E + \dot{Q}_G + \dot{Q}_{aux} \quad (7)$$

$$COP = \frac{\dot{Q}_E}{\dot{Q}_G + \dot{Q}_{aux}} \quad (8)$$

where \dot{Q}_{aux} is the energy consumption of the absorption chiller pump. Based on this method, a TRNSYS type (labelled 'Type 220') was developed to simulate the performance of the absorption chiller. The triple-effect chiller was selected from

Thermax Ltd [23], and its technical specifications at rated conditions are summarized in Table II.

TABLE II
 TECHNICAL SPECIFICATIONS OF THE TRIPLE-EFFECT ABSORPTION CHILLER USED IN THIS STUDY

Parameter	Unit	Value
CHW temperature (inlet/outlet)	°C	12/7
CW temperature (inlet/outlet)	°C	30/37
HW temperature (inlet/outlet)	°C	210/195
CHW flow rate	m ³ /hr kW _e	0.172
CW flow rate	m ³ /hr kW _e	0.191
HW flow rate	m ³ /hr kW _e	0.032
COP	-	1.81

E. Vapor Compression Chiller

A water-cooled vapor compression chiller was employed in the reference conventional system to provide the building cooling load. TRNSYS 'Type 666' was used to model the performance of the chiller. The detailed mathematical model of this type can be found in TRNSYS documentation [24].

F. Cooling Tower

An open circuit cooling tower was used to reject heat from the chiller to the ambient. TRNSYS 'Type51b' was used to simulate the performance of the cooling tower. More details about the mathematical model of this type can be found in TRNSYS documentation [21].

G. Building Load

The building considered in this paper represents a large hotel consisting of 6 floors and a basement with total floor area of 11,346 m². The building has an average window-to-wall ratio of 30.2% in total. The building walls and fabric were designed to meet minimum requirements provided by the Building Code of Australia [25]. The thermal behavior of the building was simulated using multi-zone building model 'Type 56' and the weather data module 'Type 15-2' in TRNSYS.

IV. ENERGETIC ANALYSIS

The energy performance of the proposed SHC triple-effect chiller is analyzed by the primary energy consumption of the plant (PEC_{SHC}):

$$PEC_{SHC} = PEC_{SHC,E} + PEC_{SHC,NG} \quad (9)$$

$$PEC_{SHC,E} = PEF_E \times E_E \quad (10)$$

$$PEC_{SHC,NG} = PEF_{NG} \times E_{NG} \quad (11)$$

E_E and E_{NG} are the annual energy consumed by the electric equipment and the auxiliary gas burner. PEF_E and PEF_{NG} , respectively, denote the primary energy conversion factors for electricity grid and natural gas, which are presented in Table III.

V. ECONOMIC ANALYSIS

The levelized annual total cost of the plant ($C_{tot,L}$) consists of four main elements: the capital investment (CI_L), the operating and maintenance cost (OMC_L), the fuel cost (FC_L), and the pollution cost due to CO_2 emissions ($CDEC_L$):

$$C_{tot,L} = CI_L + OMC_L + FC_L + CDEC_L \quad (12)$$

The input parameters used for the economic analysis of the proposed SHC absorption system are summarized in Tables III and IV [26]–[28].

TABLE III
 INPUT PARAMETERS USED FOR THE ENERGETIC, ECONOMIC AND ENVIRONMENTAL ANALYSES OF THE SHC ABSORPTION CHILLER PLANT IN THIS STUDY [26]

Parameter	Unit	Value
Inflation rate	%	2.9
Interest rate	%	6
Electricity price	\$/kWh	0.27
Natural gas price	\$/GJ	19
Carbon tax	\$/tonne CO_2 -e	25.4
Lifetime of the system	Year	20
Maintenance cost of the system	%	1.25
Installation, integration, and piping cost of the plant	% of capital cost	150
CO_2 emission factor for electricity grid	kg CO_2 /MWh	756
CO_2 emission factor for natural gas	kg CO_2 /MWh	184
Primary energy factor for electricity grid (PEF_E)	kWh _{PE} /kWh _E	3.07
Primary energy factor for natural gas (PEF_{NG})	kWh _{PE} /kWh _{NG}	1.22

The SHC absorption chiller proposed in this study impose additional expenses (mainly in terms of capital costs) compared to the reference conventional system. This additional cost, however, can be compensated over time due to total cumulative savings from the reduction in the system non-renewable energy consumption. The payback period (PBP) of the additional costs compared to the reference conventional system can be estimated as [29]:

$$PBP = \frac{\Delta CI_{SHC}}{CES_L + CDERC_L + OMRC_L} \quad (13)$$

where ΔCI_{SHC} is the additional cost associated with the solar absorption plant, while CES_L , $CDERC_L$ and $OMRC_L$ are the levelized annual cost of energy saving, CO_2 emissions reduction, and annual O&M cost reduction, respectively.

VI. ENVIRONMENTAL ANALYSIS

Increasing environmental concerns necessitate considering the environmental impacts of energy systems in the design stage. As such, in this study, the amount of CO_2 emissions released by the proposed SHC plant was considered as an important environmental factor to identify the carbon emission offset relative to the reference conventional system. The annual carbon dioxide emissions from the SHC plant (CDE_{SHC}) can be estimated as:

$$CDE_{SHC} = CDE_{SHC,E} + CDE_{SHC,NG} \quad (14)$$

$$CDE_{SHC,E} = E_E \times EF_{CO_2,E} \quad (15)$$

$$CDE_{SHC,NG} = E_{NG} \times EF_{CO_2,NG} \quad (16)$$

where $EF_{CO_2,E}$ and $EF_{CO_2,NG}$ are the CO_2 emission factors for grid electricity and natural gas, which are listed in Table III.

TABLE IV
 CAPITAL COST FUNCTION OF THE MAIN SYSTEM COMPONENTS (IN AUD) [26]–[28]

System component	Capital cost function
Solar collector	$Z_{SC} = 520A_a$
Storage tank	$Z_{ST} = 2,500V_{ST}$
Auxiliary heater	$Z_{AH} = 102\dot{Q}_{AH,rated}$
Absorption chiller	$Z_{ACH} = 855\dot{Q}_{ACH,rated}$
Vapor compression chiller	$Z_{WCH} = 480\dot{Q}_{WCH,rated}$
Cooling tower	$Z_{CT} = 12,966 \ln(\dot{Q}_{CT,rated}) + 103,603$
Cooling/Heating coils	$Z_{CC/HC} = 29,817(A_{CC/HC})^{0.4162}$
Pump	$Z_p = 1,062 \dot{W}_p^{0.71} \left(1 + \frac{0.2}{1 - \eta_p}\right)$
Variable Frequency Drive	$Z_{VFD} = 91 \dot{W}_p$
Controllers	$Z_{CTRL} = 6,750$

VII. SYSTEM OPTIMIZATION

Multi-objective optimization is a realistic approach to handle real-world engineering problems dealing with conflicting objectives which must be addressed simultaneously. In a multi-objective optimization problem, a set of non-dominated solutions, known as Pareto optimal solutions, is obtained, which represents a hierarchy of best possible trade-offs between the considered objective functions [30]. Genetic algorithms have been proven to provide a robust and efficient approach to achieve a set of reliable global optimal solutions to a multi-objective optimization problem [31]. As such, TRNSYS was coupled with MATLAB in the present study, using its genetic algorithm optimization toolbox to perform the multi-objective optimization of the system. The primary energy consumption and the total annual cost of the SHC plant were selected as two conflicting objective functions to be minimized simultaneously. Five design parameters were selected for the system optimization, which are presented in Table V. It should be noted that the lower and upper bounds of the collector specific area ($A_{SC,min}$ and $A_{SC,max}$) were selected in a way to limit the total solar fraction of the plant between ~25% and ~90%.

VIII. RESULTS AND DISCUSSION

To demonstrate the modeling and optimization methodology described above, a case study was developed for the proposed SHC plant integrated into the modeled reference hotel building in Sydney, Australia, a location with relative

sunny climate with annual global horizontal and beam irradiance of about 1608.5 kWh/m² and 853.9 kWh/m², respectively [32]. The annual cooling and heating load profile of the building under Sydney's climate is shown in Fig. 2.

TABLE V
 DESIGN PARAMETERS CONSIDERED FOR SYSTEM OPTIMIZATION

Design parameter	Unit	Range of variation
Solar collector specific area (A_{SC})	m ² /kW _e	$A_{SC,min} < A_{SC} < A_{SC,max}$
Storage tank specific volume (V_{ST})	L/m ²	$10 < V_{ST} < 100$
Solar pump nominal flow rate ($\dot{m}_{p1,nominal}$)	L/hr m ²	$49 < \dot{m}_{p1,nominal} < 195$
Collector set-point temperature in summer ($T_{SP,s}$)	°C	$190 < T_{SP,s} < 220$
Collector set-point temperature in winter ($T_{SP,w}$)	°C	$70 < T_{SP,w} < 100$

The maximum cooling and heating demands of the building are 965 kW and 520 kW, respectively. Accordingly, a triple-effect absorption chiller with a nominal cooling capacity of 1163 kW was selected from Thermax Ltd. The characteristic coefficients obtained for this chiller are:

$$a = -2.14, e = 3.29, s_E = 14.6, r_E = -1171.7, s_G = 7.05, \text{ and } r_G = -504.2$$

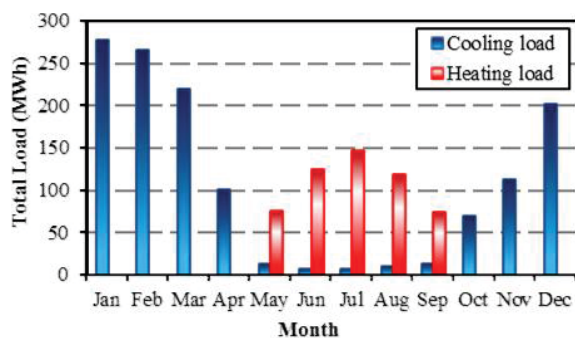

Fig. 2 Monthly load demand of the reference hotel building modeled in this study under Sydney's climate

The Pareto front of optimal solutions obtained from multi-objective optimization of the system is shown in Fig. 3. As mentioned earlier, the conflicting relation between the two objective functions is evident in this figure. The lowest primary energy consumption (and thus the minimum environmental impact) is achieved at design point A, while the total levelized cost has its highest value at this point. The highest primary energy consumption occurs at design point B, where the system total cost stands at its minimum. If the primary energy consumption was considered as the sole objective function, point A then would represent the optimal design point of the system. In other words, point A shows an extreme design where the solar energy source is most weighted to contribute to meeting the load requirements of the buildings. Were the plant levelized cost to be the sole objective in the optimization process, then point B would be preferred as the optimum design. Fig. 3 also shows the levelized cost and the primary energy consumption corresponding to the reference conventional system operating under the same conditions. As can be seen in this figure, all

optimal solutions corresponding to SHC plant outperform the conventional system, proving the acceptable energy efficiency of a gas-fired backup when used with a high-COP triple-effect chiller-based design.

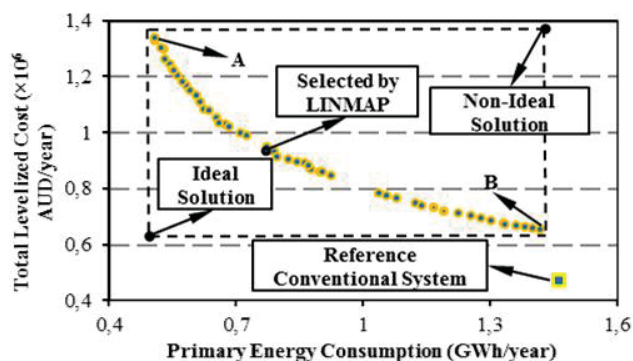

Fig. 3 Pareto front of optimal solutions obtained from multi-objective optimization of the proposed SHC triple-effect absorption chiller

To comprehensively analyze the energetic/environmental and economic performance of the proposed SHC plant, a final optimal solution should be selected from the Pareto front presented in Fig. 3. Since the dimension of the objective functions considered in this study is not the same (i.e. PEC in GWh/year and $C_{tot,L}$ in M\$/year), all objectives must be non-dimensionalized first. The Euclidian technique was therefore used to non-dimensionalize the vectors of objectives in the present work. More details about this method can be found in [33].

Assuming equal weights assigned to both objective functions, a LINMAP decision-making method was employed to determine the final optimal design point of the SHC plants. In this method, an ideal point is defined at which both objectives are at their optimal values independent of the one another [34]. The solution with a minimum spatial distance from the ideal point is selected as the desired optimal solution, which is marked in Fig. 3. It should be noted that in general no decision-making method has superiority over the other; thus, selection of the final optimal design point merely depends on the importance of each objective function to the designer under certain circumstances. The optimal values of design parameters corresponding to the final optimal point as well as points A and B are presented in Table VI. As shown in this table, the final optimal point selected by LINMAP decision-maker has reached an equal trade-off between the energetic, economic and environmental performance of the system.

The capital cost breakdown of the SHC plant at the final optimal design point is shown in Fig. 4. According to this figure, the solar collector array has the highest share of the capital cost, accounting for about 43% of the total capital cost of the plant. The absorption chiller is the second most expensive component in each configuration, comprising 25% of the total capital cost of the plant. The next highest capital costs can be attributed to the storage tank, cooling coils, cooling tower, and heating coils.

TABLE VI
 OPTIMAL DESIGN PARAMETERS OF THE PROPOSED SHC PLANT AT THREE
 INDICATIVE OPTIMAL DESIGNS

Design parameter	Point A	Point B	Selected by LINMAP
A_{SC} (m^2/kW_c)	5.2	0.8	2.9
V_{ST} (L/m^2)	63.3	30.3	49.8
$\dot{m}_{p1,nominal}$ ($L/hr m^2$)	194.6	50.3	189.6
$T_{SP,s}$ ($^{\circ}C$)	214.8	203.1	206.5
$T_{SP,w}$ ($^{\circ}C$)	79.9	73.2	74.5

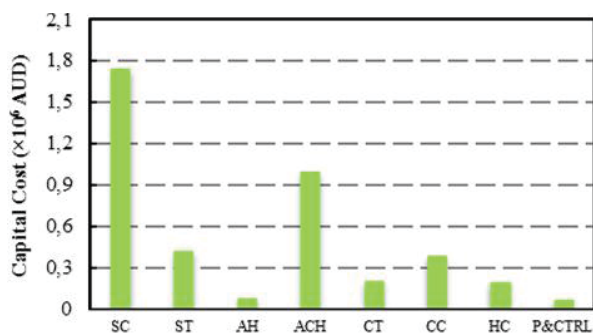

Fig. 4 Capital cost breakdown (in AUD) of the SHC plant at the final optimal design point

The performance-related results of the proposed SHC system at its extreme designs and final optimum design are presented in Table VII. As shown in this table, the highest value of solar fraction, and thus the lowest primary energy consumption and CO_2 emissions are achieved at point A, while the least energy-efficient and environmentally friendly design is obtained at point B. The multi-objective optimization approach, however, leads to a reasonable trade-off between the energetic, economic and environmental performance of the system.

TABLE VII
 PERFORMANCE-RELATED ANNUAL RESULTS OF THE SHC SYSTEM AT THREE
 INDICATIVE OPTIMAL DESIGNS

Parameter	Unit	Point A	Point B	Selected by LINMAP
A_{SC}	m^2	6021.7	947.8	3426.2
V_{ST}	m^3	381	28.7	170.6
SF	%	0.88	0.24	0.72
COP_{avg}	-	1.62	1.62	1.62
PEC	GWh/year	0.49	1.42	0.77
CDE	tonne/year	107.9	240.7	146.5
PES	GWh/year	0.99	0.11	0.69
CDER	tonne/year	205	72	166
$C_{tot,L}$	MS/year	1.33	0.66	0.94
PBP	year	105.8	47.6	63.8

The results presented in Table VII show that the proposed SHC plant at its final optimal design point has a solar fraction of 72%, resulting in an annual primary energy saving of 0.69 GWh and reducing the annual CO_2 emissions by ~166 tonnes as compared to the reference conventional system. Nevertheless, based on today's market the economic performance of the proposed SHC plant does not seem satisfactory *without* government subsidies, which is often the

case for many of renewable energy systems. The low competitive economics of the proposed SHC system relative to conventional HVAC systems is mainly due to the high capital costs of concentrating high-temperature solar collectors. In addition, the lower solar gain of concentrating PTCs due to capturing only beam radiation leads the plant to have larger collector areas to compensate for the loss of diffuse component, thereby increasing the capital cost of the solar field.

If 50% of the capital cost of the plant was financed by subsidies, the payback period of the SHC plant at the final optimal design presented in Table VI would drop just above the lifetime of the plant (~21 year), which is still unacceptable from an economic perspective. Increasing the financial incentive up to 75%, the proposed SHC plant can achieve a satisfactory payback time of about 6 years. Since such high rates of financial incentives may not always be available from public funding, another approach to improve the economics of the proposed SHC system with less reliance on public subsidies is to size the solar field to achieve lower solar fractions. In other words, the solar collector field can be (under) sized for high base load utilization, while the backup heating and cooling energy source covers the remaining more variable part of the overall building thermal load. As a case in point, for an optimal design point which has a solar fraction of about 40%, only 32% subsidies on the capital costs (of the innovative components) is required in order for the additional capital costs (compared to the reference conventional system) to be recovered in ~9 years. Thus, based on the current market the economically viable design of the proposed SHC plant is better understood as a gas-driven system with solar enhancement rather than a solar-powered system with gas cooling and heating back-up. Overall, with increasing maturity, the SHC absorption technology will likely become more competitive with conventional systems for air-conditioning applications.

IX. CONCLUSIONS

A comprehensive energetic, economic, and environmental analyses and multi-objective optimization of a novel solar-powered triple-effect LiBr-H₂O absorption chiller was carried out to evaluate the techno-economic potential of such systems for air-conditioning applications. PTCs were employed to drive the triple-effect chillers, while a gas burner was used as backup when solar heat was not sufficient. A complete dynamic simulation model of the proposed SHC plant was developed in TRNSYS program, which was coupled with MATLAB to perform the multi-objective optimization of the system, where the primary energy consumption and levelized annual total cost of the plant were minimized simultaneously. Overall, the multi-objective approach of this study satisfied both primary energy and economic and performance objectives better than single-objective optimizations alone. The optimization results indicated that the final optimum design of the proposed SHC system results in a solar fraction of 72%, achieving an annual primary energy saving of 0.69 GWh and saving ~166 tonnes of CO_2 emission as compared to

a reference conventional system. The economic performance of the system, however, was not appealing, mainly due to the high capital cost of concentrating PTCs required to drive the triple-effect chiller. It was found that ~75% public funding was required in order for the proposed SHC system to achieve a satisfactory payback period of ~6 years. Finally, our results showed that if some small amount of government subsidies is available, the solar field can be sized to achieve lower solar fractions to improve the economic feasibility of such systems. This means that the most economically viable design (today) is one in which the SHC absorption chillers are used as an enhancement to the conventional system, rather than attempting to rely mostly on solar-derived heat. Overall, the challenge for the solar industry is to lower the cost of high temperature collectors, thereby paving the way for implementation of highly-efficient triple-effect chiller systems integrated with solar thermal energy.

ACKNOWLEDGMENT

This research is funded by the CRC for Low Carbon Living Ltd (Project ID (RP1002)) supported by the Cooperative Research Centres program, an Australian Government Initiative.

REFERENCES

- [1] R. Hitchin, C. Pout, D. Butler. Realisable 10-year reductions in European energy consumption for air conditioning. *Energy and Buildings*. 86 (2015) 478-91.
- [2] A.D. Carvalho, P. Moura, G.C. Vaz, A.T. de Almeida. Ground source heat pumps as high efficient solutions for building space conditioning and for integration in smart grids. *Energy Conversion and Management*. 103 (2015) 991-1007.
- [3] Z. Sayadi, N. Ben Thameur, M. Bourouis, A. Bellagi. Performance optimization of solar driven small-cooled absorption-diffusion chiller working with light hydrocarbons. *Energy Conversion and Management*. 74 (2013) 299-307.
- [4] R. Gomri. Simulation study on the performance of solar/natural gas absorption cooling chillers. *Energy Conversion and Management*. 65 (2013) 675-81.
- [5] R. Gomri, R. Hakimi. Second law analysis of double effect vapour absorption cooler system. *Energy Conversion and Management*. 49 (2008) 3343-8.
- [6] R. Gomri. Investigation of the potential of application of single effect and multiple effect absorption cooling systems. *Energy Conversion and Management*. 51 (2010) 1629-36.
- [7] F. Calise, A. Palombo, L. Vanoli. Design and dynamic simulation of a novel polygeneration system fed by vegetable oil and by solar energy. *Energy Conversion and Management*. 60 (2012) 204-13.
- [8] G.A. Florides, S.A. Kalogirou, S.A. Tassou, L.C. Wrobel. Modelling and simulation of an absorption solar cooling system for Cyprus. *Solar Energy*. 72 (2002) 43-51.
- [9] F. Assilzadeh, S.A. Kalogirou, Y. Ali, K. Sopian. Simulation and optimization of a LiBr solar absorption cooling system with evacuated tube collectors. *Renewable Energy*. 30 (2005) 1143-59.
- [10] P.J. Martínez, J.C. Martínez, M. Lucas. Design and test results of a low-capacity solar cooling system in Alicante (Spain). *Solar Energy*. 86 (2012) 2950-60.
- [11] O. Ayadi, M. Aprile, M. Motta. Solar Cooling Systems Utilizing Concentrating Solar Collectors - An Overview. *Energy Procedia*. 30 (2012) 875-83.
- [12] Y.L. Liu, R.Z. Wang. Performance prediction of a solar/gas driving double effect LiBr-H₂O absorption system. *Renewable Energy*. 29 (2004) 1677-95.
- [13] F.J. Cabrera, A. Fernández-García, R.M.P. Silva, M. Pérez-García. Use of parabolic trough solar collectors for solar refrigeration and air-conditioning applications. *Renewable and Sustainable Energy Reviews*. 20 (2013) 103-18.
- [14] S.K. Agrawal, R. Kumar, A. Khaliq. First and second law investigations of a new solar-assisted thermodynamic cycle for triple effect refrigeration. *International Journal of Energy Research*. 38 (2014) 162-73.
- [15] T.A.H. Ratlamwala, M.A. Gadalla, I. Dincer. Performance assessment of an integrated PV/T and triple effect cooling system for hydrogen and cooling production. *International Journal of Hydrogen Energy*. 36 (2011) 11282-91.
- [16] TRNSYS 17: a transient system simulation program. Madison, USA: Solar Energy Laboratory, University of Wisconsin.
- [17] J.A. Duffie, W.A. Beckman. *Solar Engineering of Thermal Processes*. 3rd ed. Wiley, Hoboken, NJ, USA, 2006.
- [18] NEP Solar Pty Ltd, URL: <http://www.nep-solar.com/>; 2016 (accessed March 2016).
- [19] TRNSYS 17 TESS Library, Component Libraries for the TRNSYS Simulation Environment: Volume 11 Storage Tank Library Mathematical Reference.
- [20] Y.M. Han, R.Z. Wang, Y.J. Dai. Thermal stratification within the water tank. *Renewable and Sustainable Energy Reviews*. 13 (2009) 1014-26.
- [21] TRNSYS 17, Component Libraries for the TRNSYS Simulation Environment: Volume 4 Mathematical Reference.
- [22] A. Kühn, F. Ziegler. Operational results of a 10 kW absorption chiller and adaptation of the characteristic equation. *Proceedings of the International Conference Solar Air Conditioning*, Bad Staffelstein, Germany, 2005. pp. 6-7.
- [23] Thermax Ltd, URL: <http://www.thermaxglobal.com/>; 2016 (accessed March 2016).
- [24] TRNSYS TESS Library, Volume 6: HVAC Library Mathematical Reference.
- [25] Australian Building Codes and Standards, Volume 1: Commercial Buildings (Class 2-9 Buildings), URL: <http://www.abcb.gov.au/>; 2014.
- [26] A. Shirazi, R.A. Taylor, S.D. White, G.L. Morrison. Transient simulation and parametric study of solar-assisted heating and cooling absorption systems: An energetic, economic and environmental (3E) assessment. *Renewable Energy*. 86 (2016) 955-71.
- [27] A. Shirazi, R.A. Taylor, S.D. White, G.L. Morrison. A systematic parametric study and feasibility assessment of solar-assisted single-effect, double-effect, and triple-effect absorption chillers for heating and cooling applications. *Energy Conversion and Management*. 114 (2016) 258-77.
- [28] Huch Behälterbau GmbH, URL: <http://huch.com>; 2015 (accessed March 2016).
- [29] T.G. Bejan A., Moran M. *Thermal Design and Optimization*. John Wiley and Sons, New York, 1996.
- [30] X.-S. Yang. Chapter 14 - Multi-Objective Optimization. *Nature-Inspired Optimization Algorithms*. Elsevier, Oxford, 2014. pp. 197-211.
- [31] A. Konak, D.W. Coit, A.E. Smith. Multi-objective optimization using genetic algorithms: A tutorial. *Reliability Engineering & System Safety*. 91 (2006) 992-1007.
- [32] Bureau of Meteorology: Australia's Official Weather Forecasts, URL: <http://www.bom.gov.au/>; 2016 (accessed March 2016).
- [33] M.H. Ahmadi, H. Sayyaadi, A.H. Mohammadi, M.A. Barranco-Jimenez. Thermo-economic multi-objective optimization of solar dish-Stirling engine by implementing evolutionary algorithm. *Energy Conversion and Management*. 73 (2013) 370-80.
- [34] V. Srinivasan, A.D. Shocker. Linear programming techniques for multidimensional analysis of preferences. *Psychometrika*. 38 (1973) 337-69.