

Hybrid MIMO-OFDM Detection Scheme for High Performance

Young-Min Ko, Dong-Hyun Ha, Chang-Bin Ha, Hyoung-Kyu Song

Abstract—In recent years, a multi-antenna system is actively used to improve the performance of the communication. A MIMO-OFDM system can provide multiplexing gain or diversity gain. These gains are obtained in proportion to the increase of the number of antennas. In order to provide the optimal gain of the MIMO-OFDM system, various transmission and reception schemes are presented. This paper aims to propose a hybrid scheme that base station provides both diversity gain and multiplexing gain at the same time.

Keywords—DFE, diversity gain, hybrid, MIMO, multiplexing gain.

I. INTRODUCTION

ORTHOGONAL frequency division multiplexing (OFDM) is an effective technique to combat multi-path fading in wireless channel. OFDM is a multi-carrier modulation technique where data symbols modulate a parallel collection of regularly spaced the sub-carrier. The sub-carrier has the minimum frequency separation to maintain orthogonality. OFDM is commonly used for high data rate in wireless communication and has been used in various wireless communication systems. Moreover, transmission systems based on OFDM can be extended to a multiple input multiple output (MIMO) system in order to obtain high performance. MIMO system has been studied to achieve the improved performance in wireless system. The MIMO system can achieve high reliability and high data rate without the use of additional bandwidth and energy consumption in wireless communication. Therefore, base station (BS) can achieve reliability and throughput with multiple antennas by using MIMO multiplexing schemes. One of the typical MIMO multiplexing schemes is vertical Bell laboratories layered space time (V-BLAST). The V-BLAST is an effective MIMO-OFDM system which provides spatial multiplexing gain and reception diversity gain. For this reason, a lot of detection algorithms compared with V-BLAST have been proposed for the MIMO-OFDM systems. Among those detection algorithms for V-BLAST, the linear detection schemes are popular way to detect the received signals with low complexity. However, the linear detection schemes have the worse performance among MIMO detection schemes for noise enhancement. The ordered successive interference cancellation (OSIC) and the decision feedback equalization (DFE) detection scheme has better performance than linear detection. Because the detection of the first signal determines

Young-Min Ko, Dong-Hyun Ha, Chang-Bin Ha, Hyoung-Kyu Song are with uT Communication Research Institute, Sejong University, Seoul, Korea. (corresponding author to provide phone: +82-2-3408-3890; fax: +82-2-3409-4264; e-mail: songhk@sejong.ac.kr)

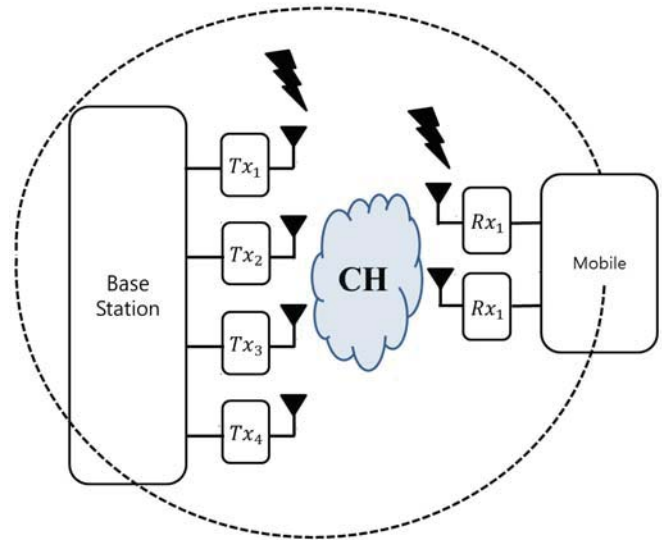

Fig. 1. Proposed wireless communication system

the overall system performance, the accurate detection of the first signal is very important to obtain high performance in DFE scheme [1][5][6]. In this paper, an efficient DFE using a cyclic delay diversity (CDD) scheme is proposed in the MIMO-OFDM system [2]. The proposed scheme obtains high performance by the accurate detection of the first signal [4].

II. SYSTEM MODEL

Fig. 1 shows the 4x2 MIMO-OFDM system. The source is a base station and uses four transmission antennas. The destination is a mobile device and uses two antennas. Let $\mathbf{s} = [s_1 \ s_2 \ \dots \ s_M]^T$ denote the $M \times 1$ vector of transmit symbols, then the corresponding $N \times 1$ receive signal vector is given by

$$\mathbf{y} = \mathbf{H}\mathbf{x} + \mathbf{n} \quad (1)$$

where \mathbf{n} is zero-mean Gaussian noise with variance σ_n^2 and $\mathbf{H} = [\mathbf{h}_1 \ \mathbf{h}_2 \ \dots \ \mathbf{h}_N]^T$ is i.i.d. random complex vector of multi-path channel with each element of $\mathbf{h}_n = [\mathbf{h}_{n1} \ \mathbf{h}_{n2} \ \dots \ \mathbf{h}_{nM}]^T$.

III. DFE SCHEME OF V-BLAST SYSTEM

V-BLAST is used to detect the multiple received signals in the MIMO-OFDM system. In V-BLAST with the

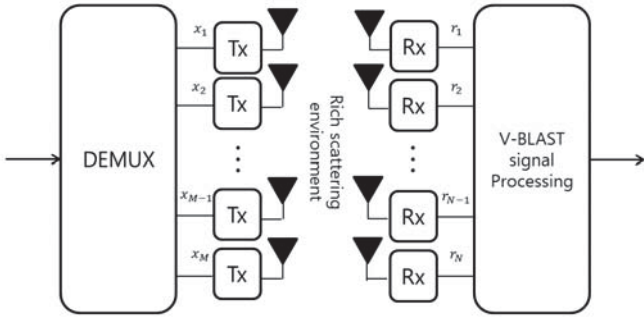

Fig. 2. V-BLAST MIMO-OFDM system

DFE scheme, the multiple received signals are detected by sequential detection scheme using QR decomposition. Detection method is as follows:

$$\mathbf{G}_{\text{MMSE}} = (\mathbf{H}^H \mathbf{H} + \sigma^2 \mathbf{I}_M)^{-1} \mathbf{H}^H. \quad (2)$$

The minimum mean square error (MMSE) detector leads to the filter \mathbf{G} matrix, where \mathbf{I}_M is $M \times M$ identity matrix. So, the channel matrix \mathbf{H} is can be expressed as follows:

$$\mathbf{H} = \begin{bmatrix} \mathbf{H} \\ \sigma \mathbf{I}_M \end{bmatrix}. \quad (3)$$

The DFE scheme which is based on QR decomposition avoids the calculation of the pseudo-inverse matrix in every layer. In this QR decomposition, $\|\mathbf{G}\|^2$ is calculated and sorted from the smallest to the largest value. \mathbf{H}_{sort} is also made by the way that the columns of channel coefficient \mathbf{H} is sorted equally with $\|\mathbf{G}\|^2$. Sorted \mathbf{H}_{sort} is decomposed to \mathbf{Q} and \mathbf{R} through QR decomposition.

$$\mathbf{G}_{\text{MMSE}} = (\mathbf{H}^H \mathbf{H}^{-1}) \mathbf{H}^H. \quad (4)$$

The matrix \mathbf{Q} is an orthogonal matrix satisfied with $\mathbf{Q}^H \mathbf{Q} = \mathbf{I}$ and \mathbf{R} is an upper triangular matrix. $M \times 1$ vector that \mathbf{Q} ingredient is removed can be gained by using \mathbf{Q}^H ,

$$\mathbf{Z} = \mathbf{Q}^H \mathbf{Y} = \mathbf{R} \mathbf{X} + \boldsymbol{\eta}, \quad (5)$$

$$\begin{bmatrix} z_1 \\ z_2 \\ \vdots \\ z_M \end{bmatrix} = \begin{bmatrix} r_{1,1} & r_{1,2} & \cdots & r_{1,M} \\ 0 & r_{2,2} & \cdots & r_{2,M} \\ \vdots & \vdots & \ddots & \vdots \\ 0 & 0 & \cdots & r_{M,M} \end{bmatrix} \begin{bmatrix} x_1 \\ x_2 \\ \vdots \\ x_M \end{bmatrix} + \begin{bmatrix} \eta_1 \\ \eta_2 \\ \vdots \\ \eta_M \end{bmatrix}, \quad (6)$$

where $\mathbf{Z} = [z_1 z_2 \dots z_M]^T$ and $\boldsymbol{\eta} = \mathbf{Q}^H \mathbf{W}$. Based on such matrix, the first detected signal is expressed by removing channel ingredient of signal which would be first detected,

$$\hat{X}_M = Q[Z_M / r_{M,M}] = Q[(r_{M,M} X_M + \eta_M) / r_{M,M}]. \quad (7)$$

TABLE I: Proposed configuration of transmission signal

Time slot	Source			
	Tx_1	Tx_2	Tx_3	Tx_4
$T = 1$	$S_{1\delta_1}$	$S_{1\delta_2}$	S_1	S_2
$T = 2$	$S_{3\delta_1}$	$S_{3\delta_1}$	S_3	S_4
$T = 3$	$S_{5\delta_1}$	$S_{5\delta_1}$	S_5	S_6
\vdots	\vdots	\vdots	\vdots	\vdots
$T = n$	S_{2n-3,δ_1}	S_{2n-3,δ_2}	S_{2n-3}	S_{2n-2}

After the first detection step, extra signals can be detected as follows:

$$\begin{aligned} \hat{X}_{M-1} &= Q[Z_{M-1} - r_{M-1,M} \cdot \hat{X}_M / r_{M-1,M-1}] \\ \hat{X}_{M-2} &= Q[(Z_{M-2} - (r_{M-2,M} \cdot \hat{X}_M + r_{M-2,M-1} \cdot \hat{X}_{M-1})) / r_{M-2,M-2}] \\ &\vdots \\ \hat{X}_m &= Q[(Z_m - \sum_{i=m-1}^M r_{m,i} \cdot \hat{X}_i) / r_{m,m}] \\ &\vdots \\ \hat{X}_1 &= Q[(Z_1 - \sum_{i=1}^M r_{1,i} \cdot \hat{X}_i) / r_{1,1}]. \end{aligned} \quad (8)$$

The DFE scheme sequentially detects signals. The first detected signal affects generally from next detected signal to the final detected signal. Also, the DFE scheme is not necessary to calculate the inverse matrix of the channel repeatedly. Therefore, the DFE scheme based on the QR decomposition has characteristic that complexity is very low.

IV. PROPOSED HYBRID DETECTION SCHEME

In this paper, the configuration of transmission signals which use the CDD scheme is proposed for the improved diversity gain and multiplexing gain at once. The accurate detection of the first signal can be obtained by the proposed configuration of transmission signal. In Fig. 1, the proposed scheme transmits the cyclically delayed signals on three antennas in order to obtain the diversity gain. Also, the proposed scheme transmits the other signals on one antenna in order to obtain the multiplexing gain. The proposed configuration of transmission signals applying the CDD scheme is presented in Table I. In each time slot, the four signals are transmitted from the base station by antennas. These signals are estimated in the mobile by the DFE scheme. In the CDD scheme, the cyclically delayed symbols give only an effect on the mobile as multi-path. δ_l is defined as the cyclic delay length of the l -th antenna in the base station. The optimal cyclic delay δ_l is defined as follows:

$$\delta_l = |\delta_1 - \delta_2| = \frac{M}{|A|}, \quad (9)$$

TABLE II: The received signals at the mobil

Time slot	Destination	
	Rx_1	Rx_2
$T = 1$	0	0
$T = 2$	$Y_{2,1} = S_{1,\delta_1}H_{1,1} + S_{1,\delta_2}H_{2,1} + S_1H_{3,1} + S_2G_{1,1} + N$	$Y_{2,2} = S_{1,\delta_1}H_{1,2} + S_{1,\delta_2}H_{2,2} + S_1H_{3,2} + S_2G_{1,2} + N$
$T = 3$	$Y_{3,1} = S_{3,\delta_1}H_{1,1} + S_{3,\delta_2}H_{2,1} + S_3H_{3,1} + S_4G_{1,1} + N$	$Y_{3,2} = S_{3,\delta_1}H_{1,2} + S_{3,\delta_2}H_{2,2} + S_3H_{3,2} + S_4G_{1,2} + N$
\vdots	\vdots	\vdots
$T = n$	$Y_{n,1} = S_{2n-5,\delta_1}H_{1,1} + S_{2n-5,\delta_2}H_{2,1} + S_{2n-5}H_{3,1} + S_{2n-4}G_{1,1} + N$	$Y_{n,2} = S_{2n-5,\delta_1}H_{1,2} + S_{2n-5,\delta_2}H_{2,2} + S_{2n-5}H_{3,2} + S_{2n-4}G_{1,2} + N$

where A is the modulation order and M is the number of carriers. In Fig. 1, base station transmits S_{2n-3,δ_1} , S_{2n-3,δ_2} at Tx_1 and Tx_2 . Therefore, those two antennas provide a diversity gain to the mobile as a diversity node. S_{2n-3} and S_{2n-2} are retransmitted from the Tx_3 and Tx_4 . Therefore, the two antennas provide a multiplexing gain to the mobile as a multiplexing node [3].

In the mobile, the received signals are expressed in Table II. $H_{1,i}$, $H_{2,i}$, $H_{3,i}$ and $G_{1,i}$ are the channels that connect the signals from base station to the mobile at the i -th antenna of the mobile. The noise at the i -th antenna of the mobile at time n is represented by $N_{n,i}$. Therefore, the received symbols at the i -th antenna of the mobile at time n are expressed as follows:

$$Y_{n,i} = S_{2n-5,\delta_1}H_{1,i} + S_{2n-5,\delta_2}H_{2,i} + S_{2n-5}H_{3,i} + S_{2n-4}G_{1,i} + N_{n,i} \quad (10)$$

The non-delayed signal and the CDD signal are expressed as follows:

$$s(n) = \frac{1}{\sqrt{M}} \cdot \sum_{k=0}^{M-1} S(k) \cdot e^{j\frac{2\pi}{M}kn}, \quad (11)$$

$$s_{\delta_{cyc}}(n) = \frac{1}{\sqrt{M}} \cdot \sum_{k=0}^{M-1} e^{-j\frac{2\pi}{M}k \cdot \delta_{cyc}} \cdot S(k) \cdot e^{j\frac{2\pi}{M}kn}, \quad (12)$$

where M denotes the number of carriers. Therefore, Eq. (10)

TABLE III: The configurations of transmission signals

Antenna Configuration	Source			
	Tx_1	Tx_2	Tx_3	Tx_4
2 - 2	S_{2n-3}	S_{2n-3,δ_1}	S_{2n-2}	S_{2n-2,δ_1}
3 - 1	S_{2n-3,δ_1}	S_{2n-3,δ_2}	S_{2n-3}	S_{2n-2}

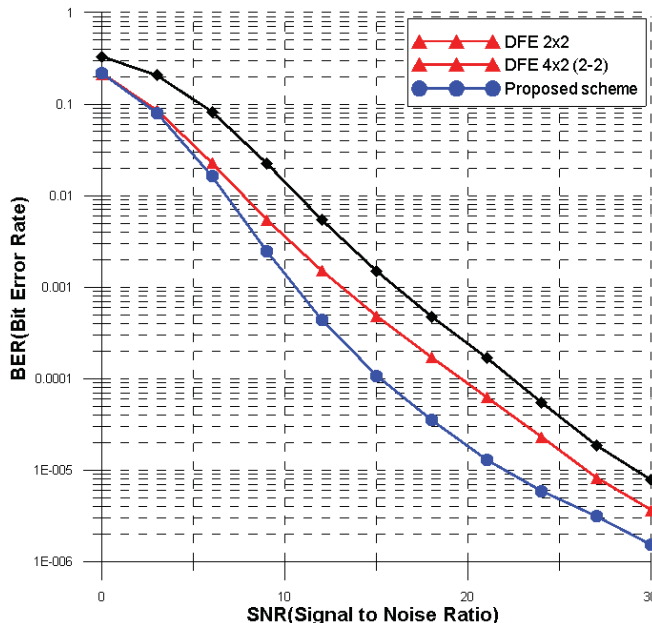

Fig. 3. BER performance of the proposed detection scheme compared to 2x2 MIMO-OFDM and 4x2 MIMO-OFDM with the configuration of 2-2 transmission signals

can be expressed as follows:

$$Y_{n,i} = S_{2n-5}(H_{1,i} + H_{2,i} \cdot e^{-j\frac{2\pi}{M}k \cdot \delta_1} + H_{3,i} \cdot e^{-j\frac{2\pi}{M}k \cdot \delta_2}) + S_{2n-4}G_{1,i} + N_{n,i} = S_{2n-5}H_i + S_{2n-4}G_{1,i} + N_{n,i} \quad (13)$$

The received symbols in the frequency domain are expressed again as follows:

$$Y_{n,i} = S_{2n-5}H_i + S_{2n-4}G_{1,i} + N_{n,i}, \quad (14)$$

where H_1 and H_2 are channel applying CDD through the three paths. The proposed scheme obtains diversity gain and multiplexing gain at the same time. Also, H_1 and H_2 are the largest columns of channel coefficient H . Therefore, S_{2n-5} is detected as the first detected signal. And next time, S_{2n-4} is detected. As a result, the proposed scheme provides the improved performance compared with the conventional DFE scheme.

V. SIMULATION RESULTS AND DISCUSSIONS

In this section, the BER performance of the proposed scheme is evaluated. In this simulation, the number of carriers is 256 and the cyclic prefix (CP) length is 64. The channel model is a Rayleigh fading channel model and the number of channel paths is 7. The cyclic delay length δ_1 is considered to 64 and the cyclic delay length δ_2 is considered to 128. The convolutional coding is applied with the constraint length of 3 and the code rate of $\frac{1}{2}$. In order to compare the performance of the proposed scheme, the configurations of transmission signals are presented in Table III. The proposed scheme has the configuration of 3 - 1 transmission signals at the relays. And the comparison subject has the configuration of 2 - 2 transmission signals at the relays. In Fig. 3, the proposed scheme has a higher BER performance

than the conventional DFE scheme in the 2x2 MIMO-OFDM system using two antennas. The proposed scheme has a higher BER performance than the 4x2 MIMO-OFDM system which applies the configuration of 2 – 2 transmission signals using four antennas. According to the simulation results, the proposed scheme can obtain the improved BER performance effectively.

VI. CONCLUSION

In this paper, the hybrid detection scheme is proposed in the MIMO-OFDM system. The proposed configuration of transmission signals provides the multiplexing gain and the diversity gain. Three antennas use the CDD scheme in order to provide the diversity gain. The other antenna transmits the different signals in order to provide the multiplexing gain. Therefore, the proposed scheme can obtain the diversity and multiplexing gain at same time.

ACKNOWLEDGMENT

This research was supported by Basic Science Research Program through the National Research Foundation of Korea(NRF) funded by the Ministry of Science, ICT and future Planning(No. 2013R1A2A2A01067708).

REFERENCES

- [1] M. S. Baek, S. Y. Yeo, Y. H. You, and H. K. Song, Combined QRD-M and DFE detection technique for simple and efficient signal detection in MIMO-OFDM systems, *IEICE Trans. Commun.*, Vol.E90-B, No.5, pp.1261–1265, May 2007.
- [2] M. Bossert, A. Huebner, F. Schuehlein, H. Haas, and E. Costa, On Cyclic Delay Diversity in OFDM Based Transmission Schemes, *Proc. of the 7th International OFDM-Workshop.*, Sep. 2002.
- [3] Daniel R. Furtato, F. Marcio Caldas, and Walter Freitas Jr, Hybrid Space-Time Diversity and Spatial-Multiplexing MIMO Cooperative Scheme for Wireless Communication Systems, *IEEE 22nd International Symposium on personal.*, pp.1657–1661, Sep. 2011.
- [4] E. Y. Lee, and H. K. Song, Improved Transmit and Detection Scheme for Hybrid STBC in MIMO-OFDM Systems, *IEICE Trans. INE and SYST.*, Vol.E96-D, No.9, pp.2131–2134, Sep. 2013.
- [5] J. K. Ahn, H. W. Jang and H. K. Song, An Improved Low Complexity Detection Scheme in MIMO-OFDM Systems, *IEICE Trans. INE and SYST.*, Vol.E97-D, No.5, pp.1336–1339, May 2013.
- [6] M. S. Baek, Y. H. You and H. K. Song, Combined QRD-M and DFE Detection Technique for Simple and Efficient Signal Detection in MIMO-OFDM Systems, *IEEE Trans. Wireless Commun.*, Vol.8, No.4, pp.1632–1638, April 2009.

Young-Min Ko received the B.S. degree in Information & Communication Engineering, Sejong University, Seoul, Korea in 2015. He is working toward to M.S. degree in the Department of information and communications engineering, Sejong University, Seoul, Korea. His research interests are in the areas of wireless communication system design and cooperative communication.

Dong-Hyun Ha received the B.S. degree in Information & Communication Engineering, Sejong University, Seoul, Korea, in 2014. He is working toward to M.S. degree in the Department of information and communications engineering, Sejong University, Seoul, Korea. His research interests are in the areas of wireless communication system design and cooperative communication.

Chang-Bin Ha received the B.S. degree in Information & Communication Engineering, Sejong University, Seoul, Korea, in 2014. He is working toward to M.S. degree in the Department of information and communications engineering, Sejong University, Seoul, Korea. His research interests are in the areas of wireless communication system design and MIMO detection.

Hyoung-Kyu Song received B.S., M.S., and Ph.D. degrees in electronic engineering from Yonsei University, Seoul, Korea, in 1990, 1992, and 1996, respectively. From 1996 to 2000 he had been managerial engineer in Korea Electronics Technology Institute (KETI), Korea. Since 2000, he has been a professor of the Department of information and communications engineering, Sejong University, Seoul, Korea. His research interests include digital and data communications, information theory and their applications with an emphasis on mobile communications.