

Low Voltage Ride through Capability Techniques for DFIG-Based Wind Turbines

Sherif O. Zain Elabideen, Ahmed A. Helal, Ibrahim F. El-Arabawy

Abstract—Due to the drastic increase of the wind turbines installed capacity; the grid codes are increasing the restrictions aiming to treat the wind turbines like other conventional sources sooner. In this paper, an intensive review has been presented for different techniques used to add low voltage ride through capability to Doubly Fed Induction Generator (DFIG) wind turbine. A system model with 1.5 MW DFIG wind turbine is constructed and simulated using MATLAB/SIMULINK to explore the effectiveness of the reviewed techniques.

Keywords—DFIG, grid side converters, low voltage ride through, wind turbine.

I. INTRODUCTION

WIND energy has been proved to be clean, sustainable, and economically the least cost option when adding new capacity to the electric grid. The 2014 Global Wind Energy Outlook shows that wind power could reach 2,000 GW by 2030, and supply up to 17-19% of global electricity [1]. As a result to the increase of the wind energy penetration into the electric power grid, electric system operators are demanding more requirements from wind power plants (WPPs) through the grid codes. According to these grid codes [2]-[5] WPPs should;

- participate in frequency control under normal conditions
- participate in voltage control under normal conditions
- have low-voltage ride-through capability
- have high-voltage ride-through capability
- support the voltage recovery by injecting reactive current and active power restoration after the fault clearance with a limited ramp values

One of the most important requirements by these codes is Low-Voltage Ride-Through capability (LVRT) which means the ability of a turbine to remain connected to the grid during fault condition. The wind energy integration grid codes for different countries can be classified into two major types; zero minimum voltage for 0.15 s and low value minimum voltage of 0.15 pu for 0.625 s [6]. The German grid code (E. ON) [7] is an example for the first type, on the other hand; FERC (USA) [8], AESO (CANADA) [9] and Irish [10] grid codes are examples for the second type. Among the generators used with wind turbines, DFIG is favorable due to its advantages

such as variable speed operation, decoupled active and reactive power control, relatively low cost and small size [11]. In a conventional DFIG wind turbine the stator is connected to the grid directly and the rotor is connected via Rotor Side Converter (RSC), DC link capacitor and Grid Side Converter (GSC). Operation of a conventional DFIG during low voltage causes large oscillations in the stator flux, increase in the rotor current, and increase in the stator current and large oscillations in the torque. These effects result in damaging the converters and huge mechanical stresses on the gearbox. On the other hand, if the WPPs are disconnected during low voltage condition to be protected, the grid will suffer power unbalance which may lead to more outage of generation units. When the DFIG wind turbine with the parameters in the appendix is subjected to low voltage of 0.15 pu starting at 0.4 s for an interval of 0.625 s, the grid voltage magnitude will have the shape shown in Fig. 1 (a) where this voltage can be divided into three main regions; region 1: The descending voltage, region 2: The constant low voltage, region 3: The ascending voltage. The values of rotor current, stator current and DC link voltage in these three regions are shown in Figs. 1 (b)-(d).

Peak values for rotor current (I_r), stator current (I_s) and DC voltage (V_{dc}) are shown in Table I relative to the steady state value.

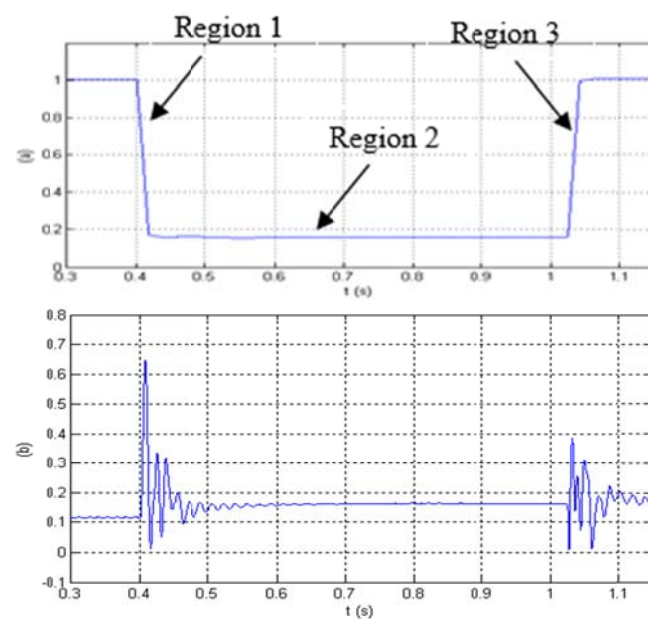

Sherif O. Zain Elabideen is with Modern Science Institute, Kuwait, (e-mail: sh.omar.zain@gmail.com).

Ahmed A. Helal is with the Arab Academy for Sciences and Technology and Maritime Transport, Alexandria, EGYPT (e-mail: ahmedanas@aast.edu).

Ibrahim F. Elarabawy is with the Electrical Engineering Department, College of engineering Alexandria University, Alexandria, EGYPT (e-mail: ibrahemarabawy@yahoo.com).

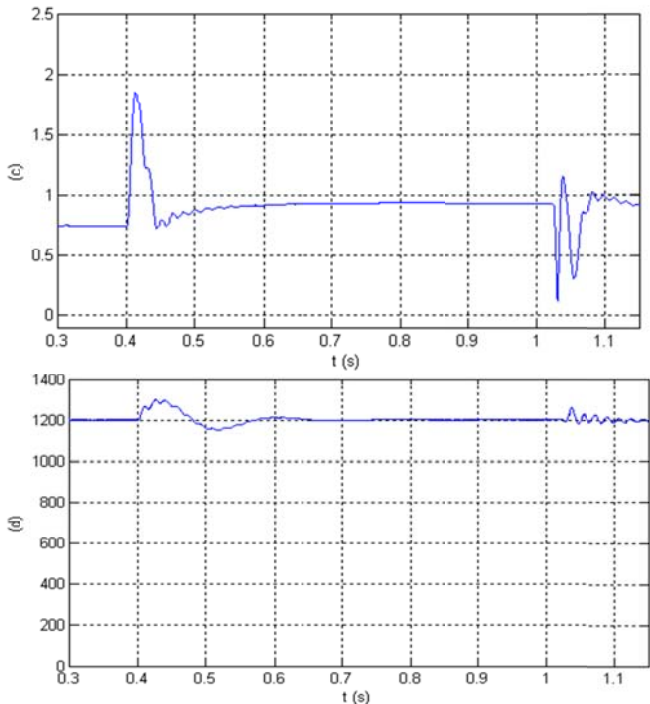

Fig. 1 DFIG wind turbine under low voltage (a) Grid voltage (p.u.) (b) Rotor current magnitude (p.u.) (c) Stator current magnitude (p.u.) (d) DC link voltage (V)

TABLE I
 PEAK VALUES OF THE ROTOR CURRENT, STATOR CURRENT AND DC VOLTAGE FOR DFIG UNDER VOLTAGE SAG RELATIVE TO ITS ST. ST. VALUES

	Region 1	Region 2	Region 3
I_r	5.5	3.3	1.4
I_s	2.5	1.25	1.6
V_{dc}	1.09	1	1.05

As can be extracted from Fig. 3 and Table I, the most dangerous region in the low voltage pattern is region 1 where the rotor current peak reaches 5.5 of its steady state value (0.12 p.u.), the stator current peak reaches 2.5 of its steady state value (0.75 p.u.) and the DC voltage peak reaches 1.09 of its steady state value (1200 V). This means, to add low voltage ride through capability to the DFIG is to make the DFIG components tolerate the high rotor current, high stator current and high DC voltage during the low voltage period especially at the beginning (region 1). Typically, the tolerable limit of the rotor current during the network fault is 2 pu, and that of the dc-link voltage is 1.2 times its nominal value [12], [13]

II. SYSTEM AND MODEL

The conventional DFIG system, as shown in Fig. 2, consists of the wind turbine, a gear, DFIG, RSC, DC link capacitor and GSC.

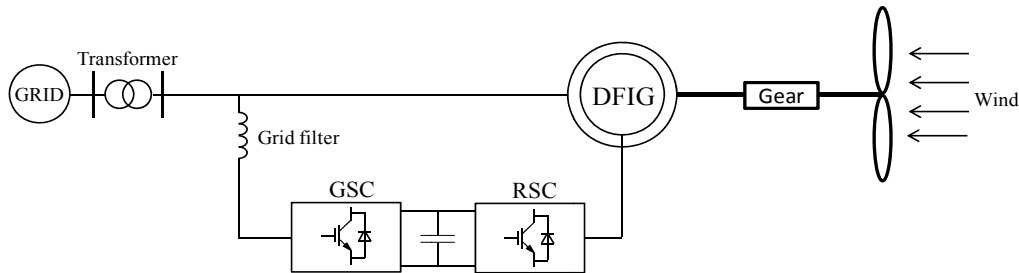

Fig. 2 Schematic diagram of the system

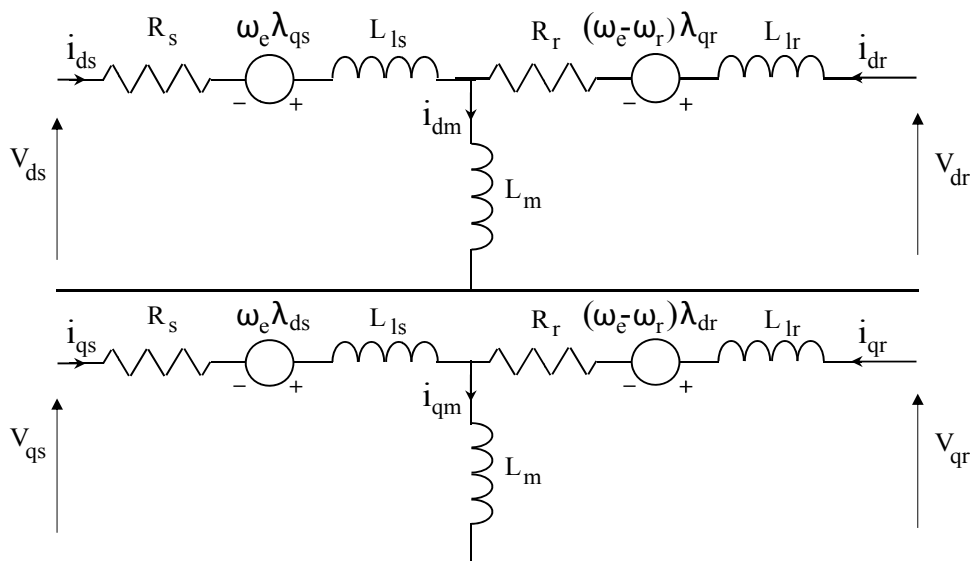

Fig. 3 DFIG equivalent circuit in the d-q reference frame

The power transmission between the DFIG and the grid is achieved by two paths; the stator power where the stator is connected directly to the grid and the rotor power where the rotor is connected to the grid via RSC to convert the rotor frequency power to dc power then GSC converts the dc power to the ac system of the grid. The equivalent circuit of the DFIG in the d-q reference frame is shown in Fig. 3.

The dynamic model of the DFIG can be described as [14];

$$v_{ds} = R_s i_{ds} + \frac{d\lambda_{ds}}{dt} - \omega_e \lambda_{qs} \quad (1)$$

$$v_{qs} = R_s i_{qs} + \frac{d\lambda_{qs}}{dt} + \omega_e \lambda_{ds} \quad (2)$$

$$v_{dr} = R_r i_{dr} + \frac{d\lambda_{dr}}{dt} - (\omega_e - \omega_r) \lambda_{qr} \quad (3)$$

$$v_{qr} = R_r i_{qr} + \frac{d\lambda_{qr}}{dt} + (\omega_e - \omega_r) \lambda_{dr} \quad (4)$$

$$\lambda_{ds} = (L_{ls} + L_m) i_{ds} + L_m i_{dr} \quad (5)$$

$$\lambda_{qs} = (L_{ls} + L_m) i_{qs} + L_m i_{qr} \quad (6)$$

$$\lambda_{dr} = L_m i_{ds} + (L_{lr} + L_m) i_{dr} \quad (7)$$

$$\lambda_{qr} = L_m i_{qs} + (L_{lr} + L_m) i_{qr} \quad (8)$$

where R_s, R_r : Stator and rotor resistances; L_{ls}, L_{lr} : Stator and rotor leakage inductances; L_m : magnetizing inductance; i_{ds}, i_{qs} : The d-q stator currents; i_{dr}, i_{qr} : The d-q rotor currents; ω_e : The supply angular frequency; ω_r : The rotor angular frequency; $\lambda_{ds}, \lambda_{qs}$: The d-q stator flux linkage; $\lambda_{dr}, \lambda_{qr}$: d-q rotor flux linkage.

The main control objectives of the conventional DFIG include regulation of stator active power and reactive power, DC link voltage. The control of the stator active and reactive power is achieved via RSC and the control of DC link voltage is fulfilled via GSC.

A. RSC Control

As presented in [15]. The field oriented control approach is used to have decoupled control on the stator active and reactive power according to;

$$P_s = -\frac{3}{2} \frac{L_m}{L_m + L_{ls}} V_s i_{qr} \quad (9)$$

$$Q_s = \frac{3}{2} \frac{V_s}{L_m + L_{ls}} (L_m i_{dr} - \frac{V_s}{\omega_e}) \quad (10)$$

The inner control loop of the RSC regulates the rotor current and the rotor current commands are generated from the stator power control.

B. GSC Control

The target of GSC control is to keep the DC link voltage constant. The dynamics of the DC link capacitor is given as

$$CV_{dc} \frac{dV_{dc}}{dt} = -P_r - P_g \quad (11)$$

where P_r is the power delivered to the rotor; P_g is the power delivered to the grid. The control of the DC link voltage V_{dc} is achieved through regulating P_g .

III. LOW VOLTAGE RIDE THROUGH TECHNIQUES

Several techniques have been proposed to achieve the target of LVRT for wind turbines since 2003. These techniques can be divided into two main categories; (a) Adding external hardware to the conventional DFIG, (b) Using different control scheme with conventional DFIG.

a) Adding External Hardware

1) Crowbar

1.1) Crowbar Resistance Only

The first proposed solution to add LVRT capability to the DFIG is using crowbar resistance. In this solution, a set of three resistors are activated to be connected to the rotor upon the fault occurrence to bypass the RSC furthermore the gating signals for RSC and GSC are turned off. However, the control of the active and reactive powers is lost during the crowbar operation and the DFIG operates as a squirrel cage induction generator which absorbs reactive power from the grid leading to worst voltage dip situation [16]-[19]. The position of the crowbar resistance is shown in Fig. 4 [17].

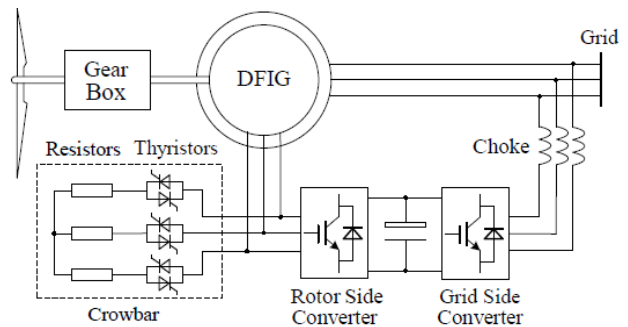

Fig. 4 DFIG with crowbar resistance

To improve the performance of the crowbar several modifications have been added as follows;

1.2) Using R-L Circuit

In this technique, R-L circuit is added to the crowbar as shown in Fig. 5 [20]. Using this method splits the rotor current during fault into two paths; one goes to the crowbar resistance and the other goes to the rotor windings through the R-L impedance. It is clear that by using this method the disconnection of the RSC during fault is avoided.

1.3) Using Series Dynamic Resistor:

In this technique, a combined converter protection is used based on the proposed Series Dynamic Resistor (SDR) and conventional crowbar. The position of the series resistance is shown in Fig. 6 [21]. The purpose of an SDR is to avoid the

frequent use of crowbar short-circuit, to maximize the operation time of the RSC, and to reduce torque fluctuations during protection operation [21].

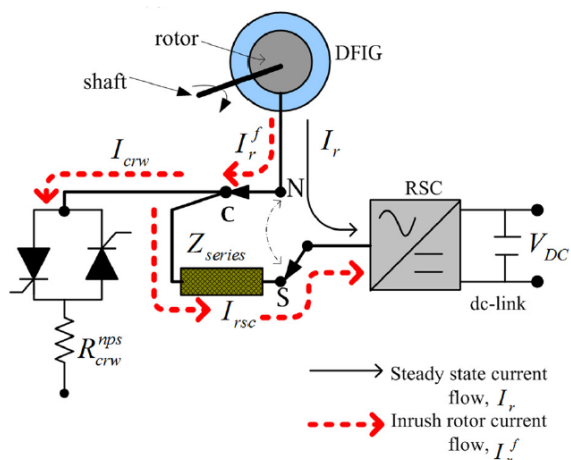

Fig. 5 The crowbar with R-L impedance

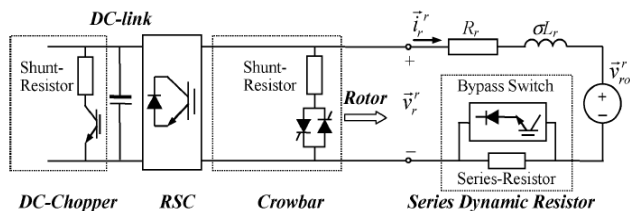

Fig. 6 The crowbar with series dynamic resistance

1.4) Time Controlled Crowbar

In this technique, the timer action crowbar is activated when the magnitude of the rotor current exceeds a threshold value set for the stated maximum IGBT pulse current of 2.0 pu. The crowbar then remains engaged for a fixed time. This method can divert transient rotor over currents, swiftly restore active and reactive power control, and provide local voltage support by delivering reactive power to the network [18].

1.5) Static Synchronous Compensator (STATCOM)

Another solution is proposed to improve the reactive power absorption of the crowbar, in this solution a STATCOM is connected at the bus where the wind turbine is connected to the power network as shown in Fig. 7 [22]. The STATCOM is applied in order to provide steady state voltage regulation and improve the short-term transient voltage stability.

2) Dynamic Voltage Restorer (DVR)

Another solution for adding LVRT capability for DFIG is using DVR in series with the DFIG to compensate the low voltage of the grid [23]-[25]. As shown in Fig. 8, the DVR consists of a battery, a three phase inverter, a filter and an injection transformer. The DVR has a great advantage of enabling DFIG to work in almost normal condition under symmetrical and asymmetrical faults. The disadvantages of DVR are its need to an external DC source and its relatively high cost.

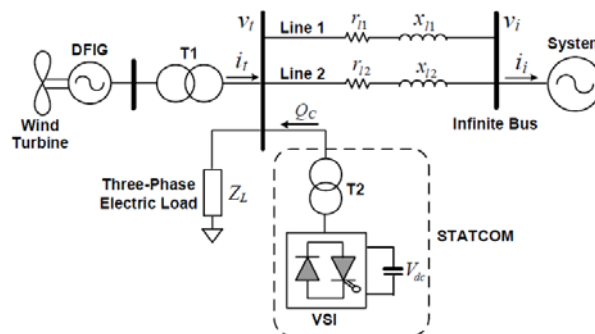

Fig. 7 Applying STATCOM to DFIG

There are two different types of controllers have been used to control the DVR;

2.1) PI Controller

The controller of the DVR is a conventional PI controller with constant proportional and integral gains.

2.2) Fuzzy Controller

A fuzzy logic is used to control the DVR as in [26]. A self tuning technique has been used to adjust the values of the proportional and integral gains. This enables the system to work with variable parameters and operating conditions.

3) Series Grid Side Converter (SGSC)

Another solution is to connect the GSC in series with the stator voltage rather than in parallel as in the conventional DFIG. This configuration can be accomplished alone or with adding extra rectifier.

3.1) Connecting the GSC in Series Instead of Parallel

This can be achieved by adding only a three phase injection transformer to connect the GSC in series with the stator instead of connecting it in parallel as shown in Fig. 9 [15], [27]. This solution suffers poor power processing capability.

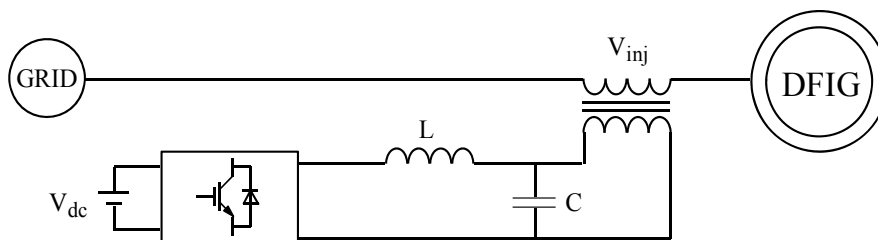

Fig. 8 Applying DVR to DFIG

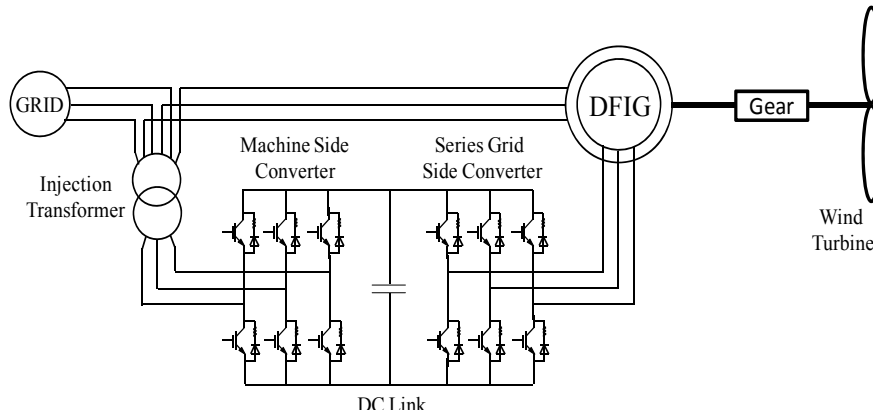

Fig. 9 Connecting GSC in series with the stator windings

3.2) Connecting GSC in Series and Adding a Rectifier

Another modification is made for SGSC to overcome the poor power processing capability, This modification is to add a parallel rectifier which shares the same DC link capacitor as shown in Fig. 10 [28]. Using a rectifier in the last topology has an obvious disadvantage which is lack of control.

4) Adding SGSC

To add an additional control to the series GSC system, another solution is introduced which is using the conventional DFIG and adding a SGSC which shares the same DC link capacitor of the DFIG configuration as shown in Fig. 11 [29], [30]. In this topology, the additional SGSC can be used to control two different variables.

4.1) Using SGSC to Control the Stator Flux

As introduced in [29] and [30], the SGSC has been used to remove the oscillations in the stator flux and so regulating the stator current and the rotor current. The disadvantage of this method is regulating the stator flux at a low value during the fault consequently; the stator power will be regulated at a lower value during the fault which differs from the operating value, leading to lose the maximum power tracking during faults. Another problem with this technique is using a flux estimator, which adds a time delay, inaccuracy and system complexity.

4.2) Using SGSC to Control the Stator Voltage

In this technique, the SGSC is used to control the stator voltage rather than the stator flux as introduced in [6]. In this technique, the same targets of containing the stator current, rotor current and the DC voltage within their safe limits has been achieved. Furthermore, the stator power is regulated at its operating value which keeps maximum power tracking even during faults. Besides, elimination of the flux estimator is used in the previous method.

5) Series Passive-Impedance Network

Another solution is adding a series passive-impedance network at the stator side of a DFIG wind turbine as shown in Fig. 12 [31]. The series switch (S_s) and the parallel switch (S_p) can be controlled to add LVRT to the DFIG. During normal

operation, the shunt element and series element are inactive. During faults, the series impedance is used for modifying the stator flux and limiting short-circuit current. The shunt impedance is used to balance the energy of the wind turbine during the grid fault. This technique is practical, reliable and has a low cost relatively [31].

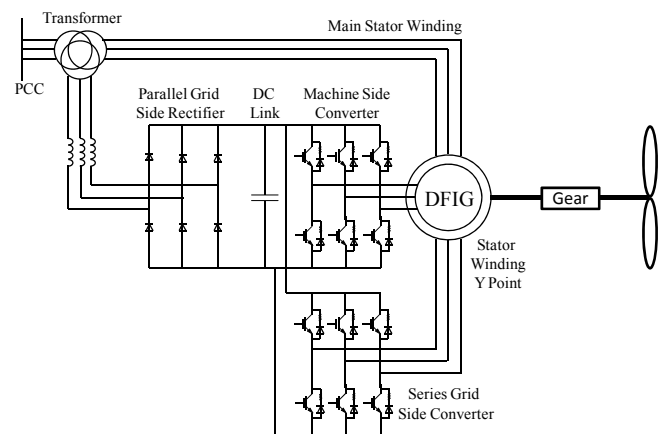

Fig. 10 SGSC with parallel rectifier

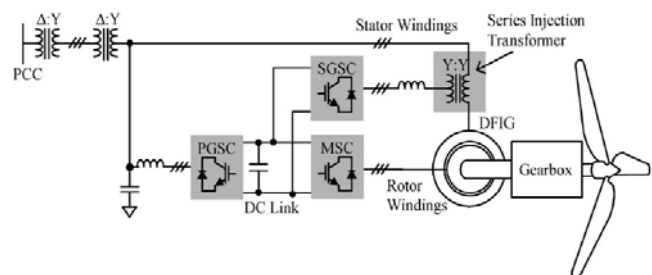

Fig. 11 Conventional DFIG with SGSC

6) Superconducting Magnetic Energy Storage (SMES)

Another solution as proposed in [32] is to connect a Superconducting Magnetic Energy Storage (SMES) unit with the PCC to improve the dynamic performance of a wind energy conversion system equipped with DFIG during low voltage. This topology depends on exchanging power between SMES unit and PCC. There are two main disadvantages for

this topology; firstly, it is effective with light sags only and secondly, its cost is relatively high.

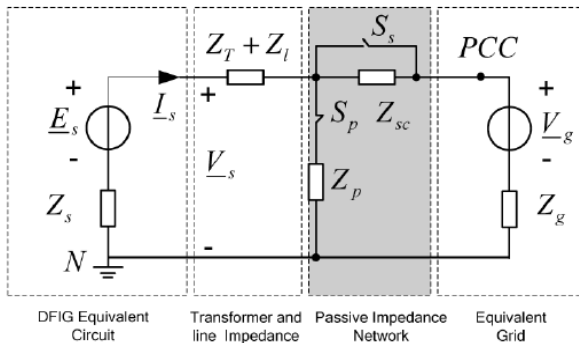

Fig. 12 DFIG with series passive-impedance network

7) Chopper Circuit

Another solution controls the DC link voltage by adding a chopper circuit to the capacitor to release the excess energy from the capacitor besides overrating the diodes of the RSC to handle the high fault current as introduced in [33].

8) Active and Passive Compensators

Another solution is using active and passive ride through technique. In this technique, a damping resistor in series with the stator (passive compensator) is used in addition to changing the mode of control of RSC to active ride-through compensator mode (active compensator). In active compensator mode the RSC uses the d and q components of the rotor currents to suppress the oscillations in the stator flux and limit the rotor current [34]. Furthermore, a nonlinear control of the GSC has been used to contain the DC-link voltage within its safe limits.

b) Using Different Control Schemes with Conventional DFIG

In this trend the conventional DFIG configuration is used without adding any external hardware, LVRT capability is added to DFIG by changing the control of RSC or/and GSC.

1) Linear Quadratic Output-Feedback Decentralized Control

One solution to achieve this is to use a linear quadratic output-feedback decentralized control strategy for both RSC and GSC instead of using PI controllers as in [35]. This solution can be used with both symmetrical and asymmetrical voltage sags.

2) Neural Networks Based Control

Another solution is to use neural networks based controllers for both RSC and GSC instead of PI controllers as proposed in [36].

3) Feed-Forward Transient Compensation Control

Another solution is to use a Feed-Forward Transient Compensation (FFTC) control scheme with proportional-integral-resonant regulators for RSC only. FFTC terms are injected into both the inner current control loop and the outer power control loop as shown in Fig. 13. The FFTC current controller improves the transient rotor current control capability [37].

4) Power Angle Control

Another solution is to use power angle control which is implemented through flux magnitude and angle control as introduced in [38]. The power angle control is applied on RSC control only as shown in Fig. 14 [38]:

5) Flux Linkage Tracking-Based Control

Another solution is using flux linkage tracking-based control strategy to suppress the short-circuit rotor current. This scheme is based on the concept that the rotor current is directly proportional to the difference between the flux linkage of the stator and the flux linkage of the rotor. In this scheme, the rotor flux linkage is controlled to track a reduced fraction of the changing stator flux linkage by switching the control algorithm of RSC during grid faults [39].

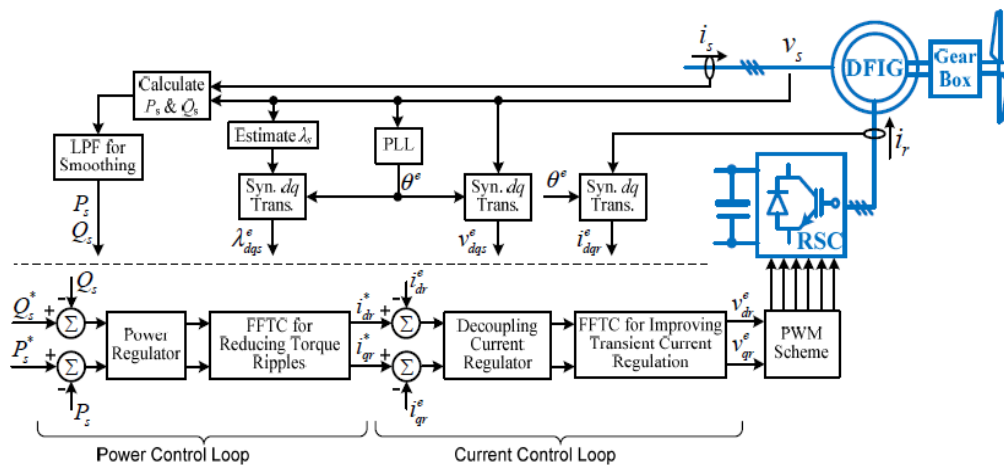

Fig. 13 FFTC scheme for DFIG

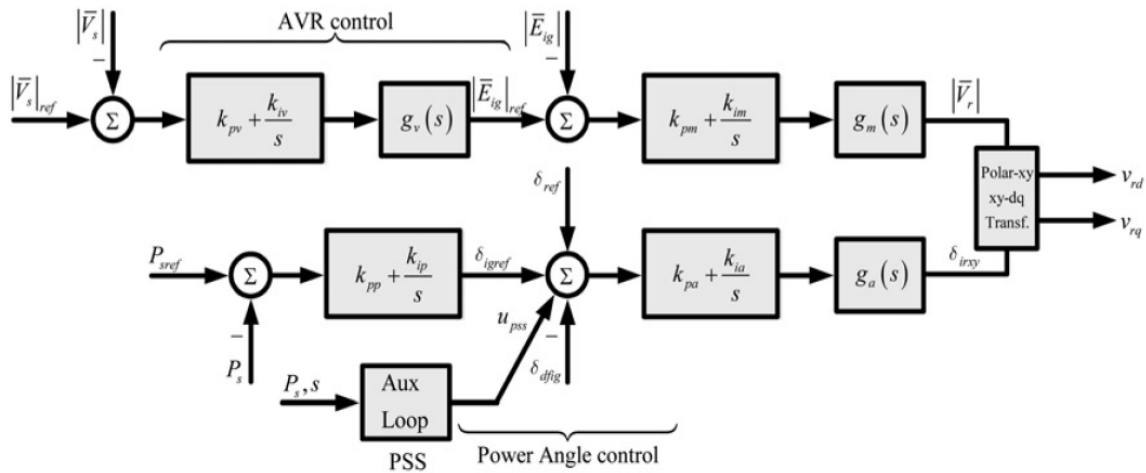

Fig. 14 Power angle control scheme in RSC control

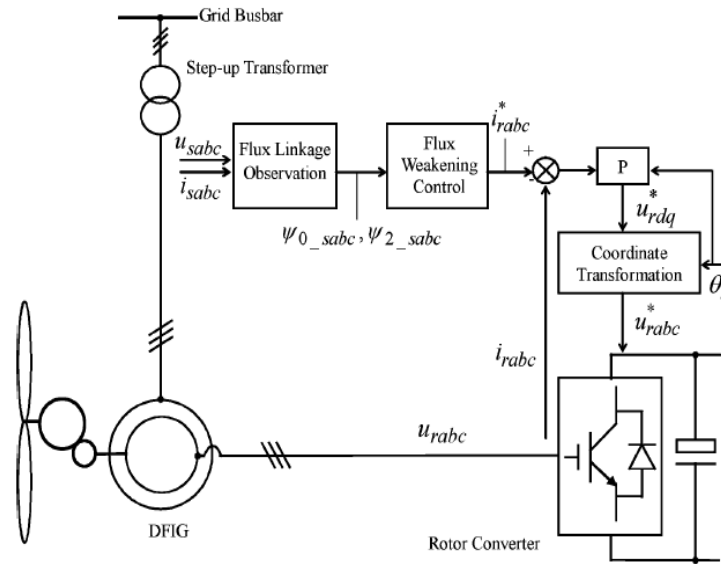

Fig. 15 Stator flux compensation using rotor voltage

6) PI and Lyapunov-Based Nonlinear Control

Another solution is presented in [40] uses a combination of proportional-integral (PI) and Lyapunov-based auxiliary nonlinear control, to stabilize the internal (stator) dynamics and improves the DFIG post-fault behavior through rotor control voltage.

7) Stator Flux Compensation Using Rotor Voltage

Another solution proposes that during fault the voltage applied from the rotor converter to the rotor winding should be used to weaken the effect of the dc and negative sequence components in the stator-flux linkage as shown in Fig. 15 [12].

8) Vector-Based Hysteresis Current Regulators

Another solution presented in [41] is to use Vector-Based Hysteresis Current Regulators (VBHCRs) are then used to control the output currents of the rotor-side and grid-side converters.

IV. PERFORMANCE EVALUATION FOR DIFFERENT LVRT TECHNIQUES

The different techniques have been evaluated according to chosen parameters and a short description has been assigned for some parameters; FULL: if the technique fully complies with the parameter, and PART: if the technique partially complies with the parameter as shown in Table II.

The behavior of all solutions which uses different control schemes with conventional DFIG is very similar and can be shown together as in Table III.

All solutions which use different control schemes with conventional DFIG are effective to add LVRT capability in moderate sags only but they have the advantage of not requiring external hardware.

V. CONCLUSION

The various techniques used to add a LVRT capability to the DFIG-based wind turbines have been classified into two

major groups. Firstly, adding extra hardware to the conventional DFIG and secondly, using different control schemes with conventional DFIG. A comprehensive review about each technique has been illustrated. A comparison between all techniques has been summarized in Tables II and III. To conclude, the first group has a higher cost and

complexity but it is much more effective with deep sags and has great results according to the grid code. The second group is effective with moderate sags only but fails with deep sags. This group has the advantages of low cost, less system complexity and more reliable.

TABLE II
EVALUATION PARAMETERS FOR ADDING EXTERNAL HARDWARE TO THE CONVENTIONAL DFIG CATEGORY

Technique	Topology	Tolerate sag < 50%	Tolerate sag > 50%	Compensate unbalanced sags	Preserve GSC control during fault	Preserve RSC control during fault	Needs flux estimator	Used for installed DFIG	Comply to new grid codes	
Adding external hardware	Crowbar	Normal	Yes	Yes	No	No	No	Yes	No	
		Using R-L	Yes	Yes	No	Yes	Yes	No	No	
		Using SDR	Yes	Yes	Yes	Yes	Yes	No	Yes	Yes
		Time controlled	Yes	Yes	No	Yes	Yes	No	Yes	Yes
		STATCOM	Yes	Yes	No	No	No	No	Yes	Yes
	DVR		Yes	Yes	Yes	Yes	Yes	No	Yes	Yes
						FULL	FULL			FULL
	GSC connected in series	Without parallel rectifier	Yes	No	No	Yes	No	Yes	No	No
		With parallel rectifier	Yes	Yes	No	Yes	No	Yes	No	No
	Adding SGSC	Flux control	Yes	Yes	Yes	Yes	No	Yes	Yes	Yes
		Voltage control	Yes	Yes	Yes	Yes	Yes	No	Yes	Yes
	Series passive impedance		Yes	Yes	Yes	Yes	Yes	YES	Yes	Yes
						FULL	PART			FULL
	SMES		Yes	No	No	Yes	Yes	No	Yes	Yes
						FULL	PART			PART
Chopper circuit		Yes	No	No	Yes	Yes	No	No	Yes	
Active and passive resistors		Yes	Yes	No	Yes	Yes	Yes	Yes	Yes	
					FULL	PART			FULL	

TABLE III
EVALUATION PARAMETERS FOR USING DIFFERENT CONTROL SCHEMES WITH CONVENTIONAL DFIG CATEGORY

Scheme	Tolerate sag < 50%	Tolerate sag > 50%	Compensate unbalanced sags	Preserve GSC control during fault	Preserve RSC control during fault	Needs flux estimator	Used for installed DFIG	Comply to new grid codes
Using different control schemes with conventional DFIG	All	Yes	No	Yes	No	-	Yes	Yes PART

APPENDIX

TABLE IV
PARAMETERS OF THE SIMULATED 1.5 MW DFIG

Symbol	Quantity	Value
V_s	Stator Voltage (rms)	575
f	Frequency (Hz)	60
R_s	Stator Resistance (pu)	0.0071
R_r	Rotor Resistance (pu)	0.005
L_s	Stator Inductance (pu)	0.171
L_r	Rotor Inductance (pu)	0.156
L_m	Magnetizing Inductance (pu)	2.9
p	Number of Pole Pairs	3
H	Inertia Constant (s)	5.04

REFERENCES

- [1] "Global Wind Energy Outlook for 2014," (Online). Available: <http://www.gwec.net/publications/global-wind-energy-outlook/global-wind-energy-outlook-2014/>. Accessed on Jan. 2016.
- [2] M. Altin, O. Goksu, RTeodorescu, and P. Rodrigues, "Overview of recent grid codes for wind power integration," in International Conference on Optimization of Electrical and Electronic Equipment, Basov, 2010, pp. 1152-1160.
- [3] R. Almeida, and J. Lopes, "Participation of Doubly Fed Induction Wind Generators in System Frequency Regulation," IEEE Transaction on Power Systems, vol. 22, no. 3, pp. 944 - 950, Aug. 2007.
- [4] Q. Wu, Z. Xu, and J. Ostergaard, "Grid Integration Issues for Large Scale Wind Power Plants (WPPs)," in Power and Energy Society General Meeting, Minneapolis, 2010, pp. 1 - 6.
- [5] R. Teodorescu, M. Liserre and P. Rodríguez, Grid Converters for Photovoltaic and Wind Power Systems, John Wiley & Sons, Ltd, 2011.
- [6] Sh. Omar, A. Helal, and I. Elarabawy, "Stator voltage sensorless DFIG with low voltage ride-through capability using series and parallel grid side converters," in International Renewable Energy Congress, Hammamet, 2016.
- [7] Erlich, U. Bachmann, "Grid code requirements concerning connection and operation of wind turbines in Germany," in Proc. IEEE Power

- Engineering Society General Meeting, San Francisco, vol. 2, pp. 1253 - 1257, Jun. 2005.
- [8] "Federal Energy Regulator Commission, Regulatory Order 661-A: Interconnection for Wind Energy," 2005. (Online). Available: <http://www.ferc.gov/industries/electric/indus-act/gi/wind.asp>. Accessed on Jan. 2016.
- [9] "Wind power facility technical requirements Revision 0," Alberta Electric System Operator, Canada, 2004. (Online). Available: http://www.aeso.ca/downloads/Wind_Power_Facility_Technical_Requirements_Revision0_signatures_JRF.pdf. Accessed on Jan. 2016.
- [10] Ireland National Grid, Grid Code Version 2, Wind Farm Power Station Grid Code Provisions, WFPS1, pp. 213 - 216, Jan. 2007.
- [11] R. Cardenas, R. Pena, S. Alepuz, and G. Asher, "Overview of Control Systems for the Operation of DFIGs in Wind Energy Applications," IEEE Trans. on Industrial Electronics, vol. 60, no. 7, Jul. 2013.
- [12] D. Xiang, L. Ran, P. Tavner, and S. Yang, "Control of a doubly fed induction generator in a wind turbine during grid fault ride-through," IEEE Trans. on Energy Conversion, vol. 21, no. 3, pp. 652-662, Sep. 2006.
- [13] H. Kasem, E. F. El-saadany, H. H. El-Tamaly, and M. A. A. Wahab, "An improved fault ride-through strategy for doubly fed induction generator-based wind turbines," IET Renew. Power Gener., vol. 2, no. 4, pp. 201-214, Mar. 2008.
- [14] D. W. Novotny and T. A. Lipo, Vector Control and Dynamics of AC Drives, New York: Oxford University Press, 1996.
- [15] Peterson, "Analysis Modeling and Control of Doubly-Fed Induction Generators for Wind Turbines". Ph.D. Thesis, Chalmers University of Technology, Goteborg, Sweden 2005.
- [16] J. Morren, and S. W. Haan, "Ridethrough of wind turbines with doubly-fed induction generator during a voltage dip," IEEE Trans. on Energy Conversion, vol. 20, no. 2 pp. 435-441, Jun. 2005.
- [17] W. Zhang, P. Zhou, and Y. He, "Analysis of the by-pass resistance of an active crowbar for doubly-fed induction generator based wind turbines under grid faults," Electrical Machines and System, Wuhan, 2008, pp.2316-2321.
- [18] G. Pannell, D. J. Atkinson, and B. Zahawi, "Minimum-threshold crowbar for a fault-ride-through grid-code-compliant DFIG wind turbine," IEEE Trans., on Energy Conversion, vol. 25, no. 3, pp. 750-759, Jun. 2010.
- [19] J. Morren, and S. W. H. Haan, "Short-circuit current of wind turbines with doubly fed induction generator," IEEE Trans. on Energy Conversion, vol. 22, no. 1, pp. 174-180, Mar. 2007.
- [20] J. Justo, and K. Ro, "Control strategies of doubly fed induction generator-based wind turbine system with new rotor current protection topology," Journal of Renewable and Sustainable Energy, vol. 4, no. 4, Aug. 2012.
- [21] J. Yang, J. E. Fletcher, and J. O. Reilly, "A series-dynamic-resistor-based converter protection scheme for doubly-fed induction generator during various fault conditions," IEEE Trans. on Energy Conversion, vol. 25, no. 2, pp. 1-8, Jul. 2009.
- [22] W. Qiao, G. Venayagamoorthy, and R. Harley, "Real-time implementation of a STATCOM on a wind farm equipped with doubly fed induction generators," IEEE Trans. on Industry Applications, vol. 45, no. 1, pp. 98-107, Jan. 2009.
- [23] Wessels, F. Gebhardt, and F. Fuchs, "Fault Ride-Through of a DFIG Wind Turbine Using a Dynamic Voltage Restorer During Symmetrical and Asymmetrical Grid Faults," IEEE Transaction on Power Electronics, vol. 26, no. 3, pp. 807-815, Mar. 2011.
- [24] Ibrahim, T. Nguyen, D. Lee, and S. Kim, "A Fault Ride-Through Technique of DFIG Wind Turbine Systems Using Dynamic Voltage Restorers," IEEE Transaction on Energy Conversion, Vol. 26, No. 3, pp. 871-882, Sep. 2011.
- [25] R. Raju, A. Karthikeyan, and C. Nagamani, "Enhanced Decoupled Power Control of Wind Turbine Driven DFIG Using DVR Under Unbalanced Grid Voltage," in Advances in Power Conversion and Energy Technologies (APCET), pp. 1-5, Aug. 2012.
- [26] E. Elhawatt, M. Hamad, K. Ahmed, and I. Elarabawy, "Low Voltage Ride-Through Capability Enhancement of a DFIG Wind Turbine Using a Dynamic Voltage Restorer with Adaptive Fuzzy PI Controller," International Conference on Renewable Energy Research and Applications, Madrid, 2013, pp. 1234 - 1239.
- [27] B. Singh, V. Emjoji, S. N. Singh, and I. Erlich, "Performance Evaluation of New Series Connected Grid-Side Converter of Doubly-Fed Induction Generator," in Power System Technology, New delhi, 2008, pp. 1-8.
- [28] P. Flannery and G. Venkataramanan, "A Unified Architecture for Doubly Fed Induction Generator Wind Turbines using a Parallel Grid Side Rectifier and Series Grid Side Converter," Power Conversion Conference. PCC 07, Nagoya, 2007, pp. 1442-1449.
- [29] P. Flannery and G. Venkataramanan, "Unbalanced Voltage Sag Ride-Through of a Doubly Fed Induction Generator Wind Turbine With Series Grid-Side Converter," IEEE Transaction on Industry Applications, vol. 45, no 5, pp. 1879-1887, Sep. 2009.
- [30] B. Singh, V. Emjoji, and S. Singh, "Performance Evaluation of Series and Parallel Connected Grid Side Converters of DFIG," in Power and Energy Society, Pittsburgh, 2008, pp. 1 - 8.
- [31] X. Yan, G. Venkataramanan, P. S. Flannery, and Y. Wang, "Voltage-sag tolerance of DFIG wind turbine with a series grid side passive-impedance network," IEEE Trans. on Energy Conversion, vol. 25, no. 4, pp. 1051-1056, Dec. 2010.
- [32] Yunus, M. Masoum, and A. Abu-Siada, "Application of SMES to enhance the dynamic performance of DFIG during voltage sag and swell," IEEE Trans. on Applied Superconductivity, vol. 22, no. 4, pp. 1051-8223, Aug. 2012.
- [33] G. Pannell, B. Zahawi, D. J. Atkinson, and P. Missailidis, "Evaluation of the performance of a DC-link brake chopper as a DFIG low-voltage fault-ride-through device," IEEE Trans. on Energy Conversion, vol. 28, no. 3, pp. 535-542, Sep. 2013.
- [34] M. Rahimi, and M. Parniani, "Coordinated Control Approaches for Low-Voltage ride-through enhancement in wind turbines with doubly fed induction generators," IEEE Trans. on Energy Conversion, vol. 25, no. 3, pp. 873-883, Sep. 2010.
- [35] M. Hossain, T. K. Saha, N. Mithulananthan, and H. R. Pota, "Control strategies for augmenting LVRT capability of DFIGs in interconnected power systems," IEEE Trans. on Industrial Electronics, vol. 60, no. 6, pp. 2510-2522, Jun. 2013.
- [36] O. Soares, H. Goncalves, A. Martins, and A. Carvalho, "Nonlinear control of the doubly-fed induction generator in wind power systems," Journal of Renewable Energy, vol. 35, pp. 1662-1670, Dec. 2009.
- [37] J. Liang, and R. G. Harley, "Feed-forward transient compensation control for DFIG wind generators during both balanced and unbalanced grid disturbances," Energy Conversion Congress and Exposition, Phoenix, 2011, pp. 2389-2396.
- [38] S. Bu, W. Du, H. F. Wang, and S. Gao, "Power angle control of grid-connected doubly fed induction generator wind turbines for fault ride-through," IET Renewable Power Generation, vol. 7, no. 1, pp. 18-27, Oct. 2012.
- [39] S. Xiao, G. Yang, H. Zhou, and H. Geng, "A LVRT control strategy based on flux linkage tracking for DFIG-based WECS," IEEE Trans. on Industrial Electronics, vol. 60, no. 7, pp. 2820-2832, Jul. 2013.
- [40] M. Rahimi, and M. Parniani, "Transient performance improvement of wind turbines with doubly fed induction generators using nonlinear control strategy," IEEE Trans. on Energy Conversion, vol. 25, no. 2, pp. 514-525, Jun. 2010.
- [41] M. Mohseni, S. M. Islam, and M. A. S. Masoum, "Enhanced hysteresis-based control of DFIG wind turbines," IEEE Trans. on Power Electronics, vol. 26, no. 1, pp. 223-234, Jan. 2011.

Sherif Omar was born in Alexandria, Egypt, in 1972. He received the B.Sc. degree in electrical engineering, from Alexandria University, Alexandria, Egypt, in 1995. He received the M.Sc. degree from Arab Academy for Sciences, Technology (AAST), Alexandria, Egypt, in 2010. He is currently manager of Modern Science Institute, Kuwait. His areas of interest include electrical machine modeling and simulation, wind energy, power quality, and power electronics applications in power systems.