

# Analytical Design of IMC-PID Controller for Ideal Decoupling Embedded in Multivariable Smith Predictor Control System

Le Hieu Giang, Truong Nguyen Luan Vu, Le Linh

Open Science Index, Electrical and Information Engineering Vol:10, No:7, 2016 publications.waset.org/10004853.pdf

**Abstract**—In this paper, the analytical tuning rules of IMC-PID controller are presented for the multivariable Smith predictor that involved the ideal decoupling. Accordingly, the decoupler is first introduced into the multivariable Smith predictor control system by a well-known approach of ideal decoupling, which is compactly extended for general  $n \times n$  multivariable processes and the multivariable Smith predictor controller is then obtained in terms of the multiple single-loop Smith predictor controllers. The tuning rules of PID controller in series with filter are found by using Maclaurin approximation. Many multivariable industrial processes are employed to demonstrate the simplicity and effectiveness of the presented method. The simulation results show the superior performances of presented method in compared with the other methods.

**Keywords**—Ideal decoupler, IMC-PID controller, multivariable Smith predictor, Maclaurin approximation.

## I. INTRODUCTION

THE intricate coupling between many measurement and control signals leads to complex interactions between input and output variables, which complicate the design of multi-loop PI/PID controllers for multivariable processes with multiple time delays. Since the controllers interact with each other, each loop cannot be tuned independently (i.e., adjusting the controller of one loop significantly affects the performance of the other loops and can destabilize the entire control system). Decentralized (multi-loop) or centralized control schemes are usually adopted to address these interactions. For controlling multivariable process with modest interaction that closely decoupled, multi-loop PI/PID controllers are usually employed because of their effectiveness, simplicity, failure-tolerant structure, and adequate performance [1]–[6]. However, they often perform poorly when the interactions are significant. In such cases, centralized (fully cross-coupled multivariable) PID controllers are advisable. Centralized control approach can be classified into two approaches: A pure centralized strategy [7], [8] and a decoupling network combined with multi-loop controllers. Due to their attractive features, decoupling networks with multi-loop PI/PID controllers have been of significant interest in both academia and industry. Numerous decoupling schemes have been developed and explored [9]–[12], though most only consider

L. Le, N.L.V. Truong and H.G. Le are with the Faculty of Mechanical Engineering, Ho Chi Minh City University of Technology and Education, Vietnam (e-mail: vuluantrn@hcmute.edu.vn, linhle@hcmute.edu.vn, gianglh@hcmute.edu.vn).

two-input, two-output (TITO) systems with dynamic decoupling. However, many multivariable processes studied in control theory and employed in industry consist of more than two inputs and outputs.

The proposed method's effectiveness was demonstrated through several examples of interacting multivariable processes. Simulation results showed that the proposed method consistently performed better than other existing methods.

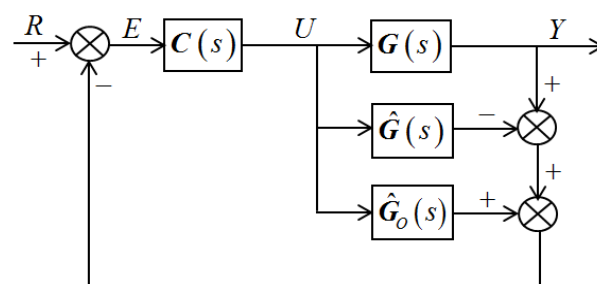

Fig. 1 Multivariable Smith predictor control

## II. METHODOLOGY

### A. Multivariable Smith Predictor

Consider a multivariable process with the following transfer matrix:

$$G = \begin{bmatrix} g_{11} & g_{12} & \cdots & g_{1n} \\ g_{21} & g_{22} & \cdots & g_{2n} \\ \vdots & \vdots & \ddots & \vdots \\ g_{n1} & g_{n2} & \cdots & g_{nn} \end{bmatrix} \quad (1)$$

where,  $g_{ij}(s) = g_{ij0}(s)e^{-L_{ij}s}$  and  $g_{ij0}(s)$  are strictly proper, stable scalar rational functions, and nonnegative  $L_{ij}$  are the time delay associated with  $g_{ij}(s)$ . Let the delay-free part of the process be denoted by  $G_0 = [g_{ij0}]$ .

The multivariable Smith predictor control scheme is shown in Fig. 1, where  $G(s)$  and  $\hat{G}$  are the process and its model, respectively.  $\hat{G}_0$  is the same as  $\hat{G}$  except that all the delays have been removed.  $C(s)$  is the primary controller. When the model is perfect, i.e.,  $\hat{G} = G$  and  $\hat{G}_0 = G_0$ , the closed-loop transfer function from  $R$  to  $Y$  becomes:

$$\mathbf{H} = \mathbf{GC}(\mathbf{I} + \mathbf{G}_0\mathbf{C})^{-1} \quad (2)$$

It can be seen that  $(\mathbf{I} + \mathbf{G}_0\mathbf{C})$  contains no delays that also provided in the multivariable controller  $\mathbf{C}$ . It suggests that the primary controller  $\mathbf{C}$  can be designed with respect to the delay free part  $\mathbf{G}_0$  and this is the main attractiveness of the control scheme. However, unlike SISO case, even though  $\mathbf{C}$  is designed such that  $\mathbf{H}_0 = \mathbf{G}_0\mathbf{C}[\mathbf{I} + \mathbf{G}_0\mathbf{C}]^{-1}$  has desired performance, the actual system performance cannot be guaranteed. This can be seen from the closed-loop transfer function as:

$$\mathbf{H} = \mathbf{GG}_0^{-1}\mathbf{G}_0\mathbf{C}(\mathbf{I} + \mathbf{G}_0\mathbf{C})^{-1} = \mathbf{GG}_0^{-1}\mathbf{H}_0 \quad (3)$$

The actual system performance could be quite poor due to the existence of  $\mathbf{GG}_0^{-1}$ . For the special case where the delays of all the elements in each row of the transfer matrix are identical, the finite poles and zeros in  $\mathbf{GG}_0^{-1}$  will all be cancelled. In this case,  $\mathbf{GG}_0^{-1} = \text{diag}\{e^{-L_{iis}}\}$  and the system output is the delayed output of  $\mathbf{H}_0$ . However, in general this desired property is not preserved. In order to overcome this problem and improve the performance of the multivariable Smith predictor control system, a decoupling Smith predictor control scheme depicted in Fig. 2 is introduced, where  $\mathbf{D}$  is a decoupler for  $\mathbf{G}$ ,  $\mathbf{Q}$  the decoupled process  $\mathbf{GD}$ , and  $\mathbf{Q}_0$  is the same as  $\mathbf{Q}$  except that all the delays are removed. Suppose that  $\mathbf{GD}$  is decoupled, it is obvious that the  $\mathbf{Q}$  and  $\mathbf{Q}_0$  will be diagonal matrices. The multivariable Smith predictor design is then simplified to multiple single-loop Smith predictor and various simple methods can be utilized to design the control systems.

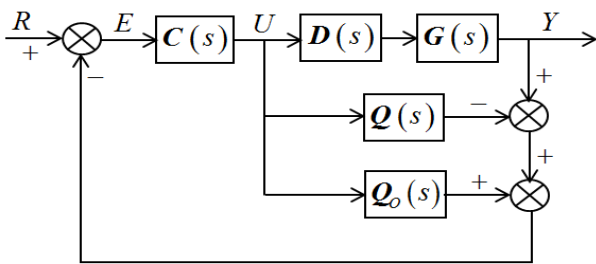

Fig. 2 Decoupling Smith control scheme

### B. Ideal Decoupling Smith Control Scheme

The decoupled process in the ideal decoupling system is expected to have a diagonal transfer function matrix in the following form:

$$\mathbf{GD} = \tilde{\mathbf{Q}} = \begin{bmatrix} q_{11} & 0 & \dots & 0 \\ 0 & q_{22} & \dots & 0 \\ \vdots & \vdots & \ddots & \vdots \\ 0 & 0 & \dots & q_{nn} \end{bmatrix} \quad (4)$$

For  $\mathbf{GD}$  to be decoupled, it is clear that the  $(i, j)^{\text{th}}$  element of an ideal decoupler can be expressed generally as:

$$\mathbf{D} = \{d\}_{ij} = \begin{bmatrix} d_{11} & d_{12} & \dots & d_{1n} \\ d_{21} & d_{22} & \dots & d_{2n} \\ \vdots & \vdots & \ddots & \vdots \\ d_{n1} & d_{n2} & \dots & d_{nn} \end{bmatrix}, \quad i, j = 1, 2, \dots, n \quad (5)$$

### C. Simplified Decoupling Design for Typical Processes

This section analytically develops an ideal decoupling for  $2 \times 2$  processes as

$$\mathbf{G} = \begin{bmatrix} g_{11} & g_{12} \\ g_{21} & g_{22} \end{bmatrix} \quad (6)$$

In accordance with the decoupling requirement in (4), four equations can be established as

$$\begin{aligned} g_{11}d_{11} + g_{12}d_{21} &= q_{11} \\ g_{11}d_{12} + g_{12}d_{22} &= 0 \\ g_{21}d_{12} + g_{22}d_{22} &= 0 \\ g_{21}d_{11} + g_{22}d_{21} &= q_{22} \end{aligned} \quad (7)$$

The decoupler elements are then given by the solution:

$$\begin{aligned} d_{11} &= \frac{g_{11}g_{22}}{g_{11}g_{22} - g_{12}g_{21}} \\ d_{12} &= -\frac{g_{12}g_{22}}{g_{11}g_{22} - g_{12}g_{21}} \\ d_{21} &= -\frac{g_{21}g_{11}}{g_{11}g_{22} - g_{12}g_{21}} \\ d_{22} &= \frac{g_{11}g_{22}}{g_{11}g_{22} - g_{12}g_{21}} \end{aligned} \quad (8)$$

The aforementioned procedure can also be simply applied to derive analytical forms of decoupling elements for other high-dimensional multivariable processes with multiple time delays.

As one can see in (4), when the order of the process increases, the resulting transfer functions of the decoupler elements become too complicated to be directly used in the design of the decoupling system. Therefore, it is necessary to approximate them suitably in reduced-order models. It should be noted that any reduction technique can be applied to fitting them into the lower-order models.

## III. DESIGN OF IMC-PID CONTROLLER

### A. IMC-PID Approach for PID Controller Design

The multivariable Smith predictor is designed based on the multiple single-loop Smith predictor control designs. Let the primary controller be:

$$\tilde{\mathbf{C}} = \{\mathbf{C}\}_{ii} = \text{diag}\{g_{c1}, g_{c2}, \dots, g_{cn}\} \quad (9)$$

The diagonal element  $c_{ii}$  is designed with respect to the delay free part  $q_{iio}$  of  $q_{ii}$  such that closed-loop system formed by  $c_{ii}(s)$  and  $q_{iio}$  has the desired performance.

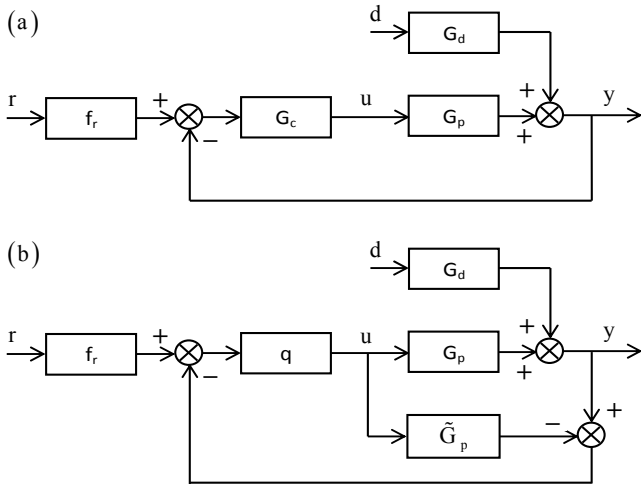

Fig. 3 Block diagram of feedback control strategies: (a) Classical feedback control (b) Internal model control

The PID controller can be designed based on the IMC approach as shown in Fig. 3 for the free delay process, where  $G_p$ ,  $\tilde{G}_p$ ,  $G_D$ ,  $G_c$ ,  $q$ , and  $f_R$  denote the transfer functions of process, process model, disturbance, feedback controller, IMC controller, and set-point filter, respectively. Since  $r$ ,  $d$ , and  $y$  correspond to the set-point input, the disturbance input, and the controlled variable. According to the IMC control structure, the controlled variable is related to the set-point as:

$$y = \frac{G_p q}{1 + q(G_p - \tilde{G}_p)} f_R r + \left[ \frac{1 - \tilde{G}_p q}{1 + q(G_p - \tilde{G}_p)} \right] G_D d \quad (10)$$

For the nominal case (i.e.,  $G_p = \tilde{G}_p$ ), the set-point and disturbance rejection responses are simplified to:

$$\frac{y}{r} = \tilde{G}_p q f_R \quad (11)$$

$$\frac{y}{d} = [1 - \tilde{G}_p q] G_D \quad (12)$$

In the classical feedback control structure, the set-point and disturbance responses are represented by:

$$\frac{y}{r} = \frac{G_c G_p f_R}{1 + G_c G_p} \quad (13)$$

$$\frac{y}{d} = \frac{G_D}{1 + G_c G_p} \quad (14)$$

According to the IMC parameterization [13], the process model  $\tilde{G}_p$  is decomposed into two parts:

$$\tilde{G}_p = P_M P_A \quad (15)$$

where  $P_M$  and  $P_A$  are the portions of the model inverted and not inverted by the controller, respectively. It is noted that  $P_A$  is usually a non-minimum phase and contains time delay term and/or right-half-plane zero. Then, the IMC controller can be described as:

$$q = p_m^{-1} \frac{(\sum_{i=1}^m \alpha_i s^i + 1)}{(\lambda s + 1)^r} \quad (16)$$

The numerator  $\sum_{i=1}^m \alpha_i s^i + 1$  causes an excessive overshoot in the servo response, which can be eliminated by introducing a set-point filter to compensate the overshoot in the servo response.

Substituting (15) and (16) into (10), yields

$$y = p_A \frac{(\sum_{i=1}^m \alpha_i s^i + 1)}{(\lambda s + 1)^r} f_R r + \left[ 1 - p_A \frac{(\sum_{i=1}^m \alpha_i s^i + 1)}{(\lambda s + 1)^r} \right] G_D d \quad (17)$$

Therefore, the ideal feedback controller for achieving the desired loop response can be easily obtained by

$$G_c(s) = \frac{q(s)}{1 - \tilde{G}_p(s)q(s)} = \frac{p_m^{-1}(s)(\sum_{i=1}^m \alpha_i s^i + 1)}{(\lambda s + 1)^n - p_A(s)(\sum_{i=1}^m \alpha_i s^i + 1)} \quad (18)$$

The resulting controller given by (18) does not have the standard PID-type controller form despite that it is physically realizable. Consequently, it is necessary to convert it into the suitable PID-type controller form more closely by using the clever approximation techniques. In this paper, a Maclaurin approximation is utilized in the different manner with previous design methods in terms of the most closely PID controller approximates the ideal feedback controller.

#### B. IMC-PID Tuning Rules for Typical Process without Time Delay Models

The most commonly used approximate model for chemical processes is the FOP model given as:

$$G_p = G_D = \frac{K}{\tau s + 1} \quad (19)$$

where  $K$  and  $\tau$  denote the process gain and the time constant, respectively. The optimum IMC filter structure in this case is found as:

$$f = \frac{\alpha s + 1}{(\lambda s + 1)^2} \quad (20)$$

Hence, the ideal feedback controller is obtained by:

$$G_c = \frac{(\tau s + 1)(\alpha s + 1)}{K[(\lambda s + 1)^2 - (\alpha s + 1)]} \quad (21)$$

The value of  $\alpha$  is evaluated as:

$$\alpha = \tau \left[ 1 - \left( 1 - \frac{\lambda}{\tau} \right)^2 \right] \quad (22)$$

The analytical tuning rules of the PID controller can be obtained by:

$$K_c = \frac{1}{2K\lambda - \alpha} \left( \tau + \alpha - \frac{\lambda^2}{2\lambda - \alpha} \right) \quad (23)$$

$$\tau_i = \tau + \alpha - \frac{\lambda^2}{2\lambda - \alpha} \quad (24)$$

$$\tau_d = \frac{\tau\alpha(2\lambda - \alpha)}{(\tau + \alpha)(2\lambda - \alpha) - \lambda^2} - \frac{\lambda^2}{2\lambda - \alpha} \quad (25)$$

For the other process models, one can be easily applied the similar above-mentioned procedure.

#### IV. SIMULATION STUDY

In order to have a fair comparison, the IAE criterion is considered here for the set-point tracking.

$$IAE = \int_0^{\infty} |e(t)| dt \quad (26)$$

To evaluate the magnitude of the manipulated input usage, the total up and down movement of the control signal is considered as:

$$TV = \sum_{k=1}^T |u(k+1) - u(k)| \quad (27)$$

TV is a good measure of the smoothness of controller output and should be small [14].

The robustness of a control system is one of the most important issues in any controller design, because the dynamics of real plants usually have many sources of uncertainty, which cause poor performance or even instability in the control systems. In this study, a well-known method for robust stability [14] is introduced for a fair comparison with other existing controller design methods.

The robust stability can be examined under output multiplicative uncertainty. For a multi-delay process with an output multiplicative uncertainty of  $\Delta_0$ , the upper bound of the robust stability can be written as

$$\gamma = \bar{\sigma}(\Delta_0) < 1 / \bar{\sigma} \left[ \left( I + G(j\omega)G_c(j\omega) \right)^{-1} G(j\omega)G_c(j\omega) \right] < \underline{\sigma} \left[ I + \left( G(j\omega)G_c(j\omega) \right)^{-1} \right], \quad \forall \omega \geq 0 \quad (28)$$

where  $G(j\omega)G_c(j\omega)$  is invertible.

To insure a fair comparison, the degree of robust stability will be held at the same level for all of the design methods being compared. In the simulation study, the proposed multi-loop PI controller is tuned by adjusting the closed-loop time constant,  $\lambda_i$ , so that the  $\gamma$  value of the proposed control system is kept the same as or larger than those of the other methods.

In this section, a pilot-scale distillation column consisting of an eight-tray plus re-boiler that introduced by Wood and Berry (WB) [15] is considered for the separation of methanol and water. The open-loop transfer function matrix is given by:

$$G(s) = \begin{bmatrix} \frac{12.8e^{-s}}{16.7s + 1} & \frac{-18.9e^{-3s}}{21s + 1} \\ \frac{6.6e^{-7s}}{10.9s + 1} & \frac{-19.4e^{-3s}}{14.4s + 1} \end{bmatrix} \quad (29)$$

The ideal decoupler network is designed based on (8):

$$D(s) = \begin{bmatrix} 2.01 & \frac{2.967e^{-0.852s}}{0.986s^2 + 1.406s + 1} \\ 0.684 & 2.01 \end{bmatrix} \quad (30)$$

TABLE I  
 CONTROLLER PARAMETERS FOR THE WB COLUMN

Tuning method	Loop	$K_{ci}$	$\tau_{ii}$	$\lambda_i$
Proposed	1	0.440	8.50	5
	2	-0.072	14.00	12
SAT [16]	1	0.87	3.25	-
	2	-0.09	10.40	-
Lee <i>et al.</i> [17]	1	0.24	8.36	4.55
	2	-0.10	7.46	4.55
Ho <i>et al.</i> [18]	1	0.57	20.70	-
	2	-0.11	12.88	-

TABLE II  
 RESULTING PERFORMANCE INDICES FOR THE WB COLUMN

Tuning method	Set-point		Disturbance		$\gamma$
	IAE	TV	IAE	TV	
Proposed	3.153	3.95	100.00	10.75	0.47
SAT [16]	24.60	4.24	136.46	11.58	0.33
Lee <i>et al.</i> [17]	25.87	1.17	165.75	7.75	0.47
Ho <i>et al.</i> [18]	29.74	2.12	188.42	8.12	0.47

The decoupled process in the ideal decoupling system can be obtained by:

$$q_{11} = g_{11} = \frac{12.8e^{-s}}{16.7s + 1} \quad (31)$$

$$q_{22} = g_{22} = \frac{-19.4e^{-3s}}{14.4s + 1} \quad (32)$$

Considering (22)-(25), the controller parameters of PID controller can be calculated and listed in Table I. The WB column in (29) is one of the most representative TITO process models widely used for evaluating the performance of the

multi-loop controllers. The performance of the proposed method was compared with those by the existing design methods such as the sequential auto-tuning (SAT) [16], Lee et al. [17], and Ho et al. [18] methods.

In order to ensure a fair comparison, the robust stability is examined for all of the comparative design methods by using (28). The proposed controller was tuned to have  $\gamma = 0.47$  so that the robust level is the same as those of Lee et al. [17] and Ho et al. [18], and higher than that of SAT [16]. The sequential unit step changes in the set-point were made to the 1st and 2nd loops, respectively. The sequential unit step changes in the disturbance were also made to the 1st and 2nd loops, respectively. For the design of the proposed controller, the order of the IMC filter was set to 1 for all of the loops.

The resulting performance indices are listed in Table II. The closed-loop responses to the set-point and disturbance changes are shown in Fig. 4, respectively.

It is apparent from the table and figures that the proposed controller provides the superior performance for both the set-point tracking and disturbance rejection.

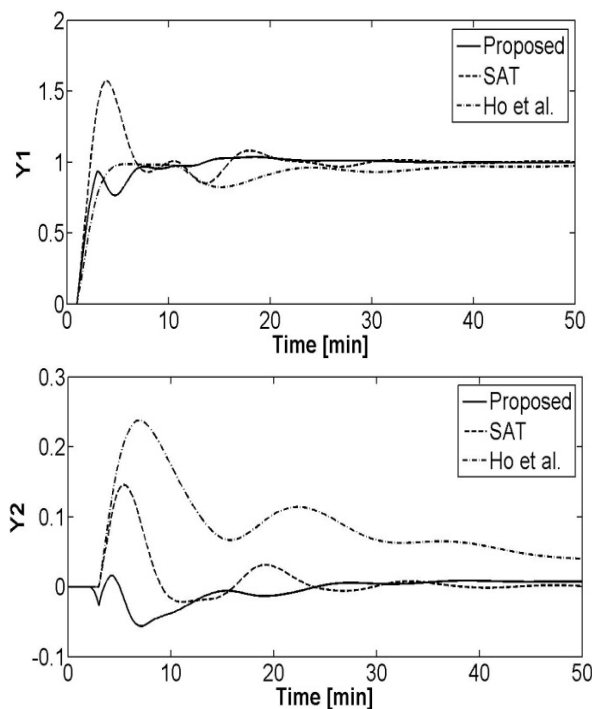

Fig. 4 Closed-loop responses to the unit step changes in the set-point for the WB column

#### V. CONCLUSION

In this paper, an analytical design method of IMC-PID controller for multivariable Smith predictor. The ideal decoupler network can be successfully applied to decompose the complex multivariable Smith predictor control systems into an  $n$  number of simple equivalent Smith predictor for the SI/SO systems, which the dynamic interaction is involved systematically. The controller can be designed simply as the PI/PID controllers for the free-delay process models of each diagonal element of multivariable process. Therefore, the

proposed method is straightforward and easy to implement in the multivariable control systems. The robustness and performance can be efficiently compromised by adjusting a single parameter, i.e., the closed-loop time constant. For a fair comparison, the maximum upper bound in the output multiplicative uncertainty for the robust stability was utilized. The time-domain simulation demonstrates the superior performance of the proposed controller with a fast and well-balanced closed-loop time response for both the set-point and load changes.

#### ACKNOWLEDGMENT

This work was supported by the HCM City University of Technology and Education (HCMUTE), Vietnam.

#### REFERENCES

- [1] W. L. Luyben, "Simple method for tuning SISO controllers in multivariable systems," *Ind. Eng. Chem. Process Des. Dev.* vol.25, pp. 654-660, 1986.
- [2] P. J. Campo and M. Morari, "Achievable closed-loop properties of systems under decentralized control: conditions involving the steady-state gain," *IEEE Trans. Autom. Control*, vol. 39, pp. 932-943, 1994.
- [3] J. Lee, W. Cho and T.F. Edgar, "Multi-loop PI controller tuning for interacting multivariable processes," *Comp. Chem. Eng.*, vol. 22, pp. 1711-1723, 1998.
- [4] N.L.V. Truong and M. Lee, "Independent design of multi-loop PI/PID controllers for interacting multivariable processes," *J. Process Control*, vol. 20, pp. 922-933, 2010.
- [5] N.L.V. Truong and M. Lee, "Analytical design of multi-loop PI controllers for interactive multivariable processes," *JCEJ.*, vol 43, pp.196-208, 2010.
- [6] N.L.V Truong and M. Lee, "Multi-loop PI controller design based on the direct synthesis for interacting multi-time delay processes," *ISA Trans.*, vol. 49, pp.79-86, 2010.
- [7] Q. C. Wang, T. H. Lee, and C. Liu, *Relay feedback: Analysis, identification and control*. London, UK: Springer, 2003.
- [8] Q. C. Wang, Y. Zhang, and M. S. Chiu, "Non-interacting control design for multivariable industrial processes," *J. Process Control*. vol. 13, pp. 253-265, 2013.
- [9] W. L. Luyben, "Distillation decoupling," *AIChE J.*, vol. 16, pp.198-203, 1970.
- [10] M. Waller, J. B. Waller, and K. V. Waller, "Decoupling revisited," *Ind. Eng. Chem. Res.*, vol. 42, pp. 4575-4577, 2003.
- [11] W. J. Cai, W. Ni, M. J. He, and C. Y. Ni, "Normalized decoupling-A new approach for MIMO processes control system design," *Ind. Eng. Chem. Res.*, vol. 47, pp. 7347-7356, 2008.
- [12] J. Garrido, F. Vázquez, and F. Morilla, "An extended approach of inverted decoupling," *J. Process Control.*, vol. 21, pp. 55-68, 2011.
- [13] M. Morari and E. Zafiriou, *Robust Process Control*. NJ, USA: Englewood Cliffs, Prentice Hall, 1989.
- [14] S.L. William, *Control System Fundamentals*. NY, USA: CRC Press, 1999.
- [15] R.K. Wood, and M.W. Berry, "Terminal composition control of binary distillation column," *Chem. Eng. Sci.*, vol. 28, pp. 1707-1717, 1973.
- [16] A.P. Loh, C.C. Hang, C.K. Quek, and V.U. Vasnani, "Autotuning of multi-loop proportional - integral controllers using relay feedback," *Ind. Eng. Chem. Res.*, vol. 32, no. 6, pp. 1102-1107, 1993.
- [17] M. Lee, K. Lee, C. Kim, and J. Lee, "Analytical design of multi-loop PID controllers for desired closed-loop responses," *AIChE J.*, vol. 50, pp. 1631-1635, 2004.
- [18] W. H. Ho, T.H. Lee, and O.P. Gan, "Tuning of multi-loop PID controllers based on gain and phase margin specifications," *Ind. Eng. Chem. Res.*, vol. 36, pp. 2231-2238, 1997.