

Diagonal Crack Width of RC Members with High Strength Materials

J. Y. Lee, H. S. Lim, S. H. Yoon

Abstract—This paper presents an analysis of the diagonal crack widths of RC members with various types of materials by simulating a compatibility-aided truss model. The analytical results indicated that the diagonal crack width was influenced by not only the shear reinforcement ratio but also the yield strength of shear reinforcement and the compressive strength of concrete. The yield strength of shear reinforcement and the compressive strength of concrete decreased the diagonal shear crack width of RC members for the same shear force because of the change of shear failure modes. However, regarding the maximum shear crack width at shear failure, the shear crack width of the beam with high strength materials was greater than that of the beam with normal strength materials.

Keywords—Diagonal crack width, high strength stirrups, high strength concrete, RC members, shear behavior.

I. INTRODUCTION

THE control of diagonal crack width of reinforced concrete (RC) members is important from the viewpoints of serviceability and deformability of RC structures. There have been great advances in concrete technology during the last one hundred years. The improvement in high-strength, high performance, fiber-reinforced, and other material and structural properties in concrete achieved earlier are now accepted as routine and various types of advanced high strength concrete have been widely used. However, in spite of many of the improvements in concrete technology that have been made over the year, much remains to be developed about concrete technology related to high strength materials. In particular, to increase the applicability of high strength materials such as high-strength concrete, high-strength steel bars, and FRP sheets, it is needed to research on the crack control of RC members with high strength materials. Many researches on the crack control of RC members with high-strength concrete have been carried out for the last a few decades, while the researches on RC members with high-strength steel bars are relatively few.

For last two decades, much research on the high yield strength of reinforcement has been conducted in USA, Japan, and European countries. As representative cases, research on Grade 100 reinforcement has been actively carried out in USA for last over 10 years [1], [2]. In particular, performance evaluation of Grade 100 reinforcement has focused on shear and bond capacities. As for Japan, applicability of the high

yield strength of reinforcement (800 MPa to 1000 MPa) on RC structures has been performed in terms of “New RC Project”. This results in many of RC structures incorporating the high yield strength of reinforcement [3].

According to the ACI 318-11 design code [4], for non-prestressed flexural members, the yield strength of longitudinal tension steel used in design calculations shall not exceed 550 MPa to reserve adequate deformability and control deflections and cracking. The ACI 318-11 code also limits the yield strength of shear reinforcement used in shear design to 420 MPa for two reasons; first to provide a control on diagonal crack width and second to prevent possible sudden shear failure due to concrete crushing before yielding of stirrups due to over shear reinforcement. In the 1995 ACI design code, however, the limitation of 420 MPa for shear reinforcement was raised to 550 MPa for welded deformed wire reinforcements. [5].

The extensive study on the flexural crack width has been carried out, *while the understanding* of the diagonal crack width of RC members with high strength materials has been somewhat less particular. In this study, the diagonal crack widths of RC members with various types of materials are analyzed by simulating a compatibility-aided truss model.

II. A MODEL FOR THE ESTIMATION OF DIAGONAL CRACK WIDTH

A. Evaluation of Diagonal Crack Width

Leonhard and Walther indicated it by experimental tests that the diagonal crack width became smaller as the amount of shear reinforcement increased. Moreover, they concluded, for the tested specimens with the same amount of shear reinforcement, that the diagonal crack width of the tested specimens in which shear reinforcement was arranged vertically to the diagonal crack inclination was smaller than that of the specimens without vertically arranged shear reinforcement to the diagonal crack inclination. Place and Regan [6] proposed an equation to estimate the diagonal crack width based on the experimental results as given in (1):

$$w_{max} = \frac{s \sin \alpha}{10^6 \rho_w (f_c')^{1/3}} \left(\frac{V_n - V_c}{bd} \right) \quad (1)$$

where, w_{max} : maximum diagonal crack width, s : spacing of shear reinforcement in direction of span, α angle between shear reinforcement and: direction of span, ρ_w : shear reinforcement, f_c' : compressive strength of concrete, V_n : shear strength, V_c : shear strength contributed by concrete, b : web width of section, d : effective depth of section. On the other hand, [7] estimated the crack width in, (2) based on EC-02 design code [8].

J. Y. Lee is with the School of Civil and Architectural Engineering, Sungkyunkwan University, Suwon, Republic of Korea (corresponding author, phone: +82-31-290-7564; fax: +82-31-2907570; e-mail: jungyoon@skku.edu).

H. S. Lim and S. H. Yoon are with the Department of Civil, Architectural, and Environmental Engineering, Sungkyunkwan University, Suwon, Republic of Korea (e-mail: hyesssun@hanmail.net, yundding@hanmail.net).

$$w = s_c \quad (2)$$

$$s_c = \frac{1}{\left(\frac{\sin \varphi}{s_x} + \frac{\cos \varphi}{s_y}\right)} \quad (3.a)$$

$$s_x = 2 \left(c_x + \frac{s_{xm}}{10} \right) + 0.25 k_1 \frac{d_{bx}}{\rho_x} \quad (3.b)$$

$$s_y = 2 \left(c_y + \frac{s_{ym}}{10} \right) + 0.25 k_1 \frac{d_{by}}{\rho_y} \quad (3.c)$$

where, c_x and c_y : clear concrete cover in the x- and y-directions, respectively, s_{xm} and s_{ym} : maximum spacing between longitudinal steel bars in the x- and y- directions, respectively, k_1 : coefficient that characterized bond properties of bars, $k_1=0.4$ for deformed bars and $k_1=0.8$ for plain bars, d_{bx} and d_{by} : steel bar diameter in the x- and y- directions, respectively, ρ_x and ρ_y : steel reinforcement ratio in the x- and y- directions, respectively, φ : inclination of diagonal cracks to member axis.

Even if (1) and (2) are relatively simple equations to predict the diagonal crack width of RC members, it is not so simple to estimate the diagonal crack width. In order to predict the diagonal crack width with a good accuracy, a sophisticated truss model considering the mechanism of materials was used in this study.

The classical 45-degree truss model for RC beams with shear reinforcement was proposed by [9], [10] at the turn of 20th century. The classical truss model is unique to explain the shear mechanism of cracked RC beams and the equations derived from the equilibrium conditions are simple to be used as the equations for the shear resistance of shear reinforcement in the ACI 318 design code. However, by assuming the inclination of the diagonal tension crack to the horizontal axis, φ , is equal to 45 degree, the predicted shear strength by this model is conservative with respect to the experimentally observed shear strength in case of RC beams with shear reinforcement more than their upper limit. As a result, two different improved approaches of truss model had been developed in calculating the various value of the inclination of the diagonal tension crack, φ . The first approach is based on the lower bound theory of plasticity that was developed by Nielsen [11]. In the second approach, the inclination of the diagonal tension crack is derived from the equilibrium conditions of forces and compatibility conditions of deformations.

In the plasticity truss model, the inclination of the diagonal crack is a function of the amount of shear reinforcement, $\rho_w f_{wy}$, (f_{wy} is the yield strength of shear reinforcement) and the value of various from 0 degree to 45 degree corresponding to the value of $\rho_w f_{wy}$. The shear design method adopted by the AIJ guidelines [12] is also based on the lower bound theory of plasticity and on the superposition of truss and arch mechanisms. This model limits the inclination of the diagonal crack from 26.7 degree to 45 degree. It is believed that this approach is more theoretical than an empirical one. However, the predicted stress state of materials (concrete and shear reinforcement) at failure does not necessarily correspond to the

experimentally observation. Some tests indicated that the stress of shear reinforcement did not reach the yield strength although the theoretical prediction required yielding. It may also be remarked the opposite case, i.e., concrete does not reach the yield strength when the amount of shear reinforcement, $\rho_w f_{wy}$, is very small. A truss model considering the mechanism of materials (equilibrium of forces, compatibility of deformations, and constitute laws of materials) has been developed [7], [13]. This truss model, so called compatibility-aided truss model, calculate the inclination of the diagonal tension crack from the equilibrium conditions of forces and compatibility conditions of deformations. This model is capable of tracing the shear response of RC member until the member fails in shear. Moreover, the compatibility-aided truss model expects that shear and normal stresses on the surface of the diagonal cracks can be transmitted by the rough shape of crack surface [14]. However, this model is basically developed to predict the shear behavior of RC members subjected to pure shear, such as RC panel or membrane plate. In order to calculate the shear behavior of RC member with better accuracy, the stress characteristics of RC members should be considered. In this study, a compatibility-aided truss model that is capable of tracing the response of RC members for shear is used to predict the inclination of diagonal crack of RC members. In the model, the effect of bending moment on shear behavior was considered.

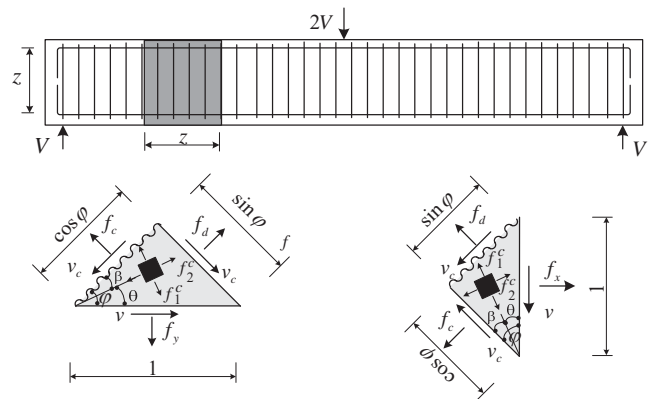

Fig. 1 A compatibility aided truss model

B. Equilibrium Conditions

In a compatibility aided truss model, the concrete stress state at the critical shear failure section is given by the normal stress parallel to the crack inclination and the acting crack stresses due to aggregate interlock. From the equilibrium conditions of forces in Fig. 1, the following equations are obtained [14], [15].

$$f_d = -\frac{2v}{\sin 2\varphi} - 2v_c \cot 2\varphi + f_c \quad (4)$$

$$v = v_c + (f_c - f_y) \cot \varphi \quad (5)$$

$$f_y = -\rho_w f_{wy} \quad (6)$$

where f_d : normal stress parallel to the crack inclination, v : shear stress, φ : inclination of diagonal crack, v_c : shear stress at

cracked surface due to aggregate interlock, f : normal stress at cracked surface due to aggregate interlock, f_y : vertical compressive stress of the concrete element induced from shear reinforcement, ρ_w : shear reinforcement ratio, f_{ws} : stress of shear reinforcement.

The angle β between the inclination of diagonal crack, φ , and the inclination of principal compressive stress, θ , is calculated by (7).

$$\tan 2\beta = \frac{2v_c}{-f_d + f_c} \quad (7)$$

In case of RC beams or columns, bending moment influences on the shear behavior. In this study, (8) and (9) were used to

consider the effect of bending moment on the shear response of RC members.

$$f_{com} = \frac{V \cdot \cot \varphi}{2 \cdot A_{sc}} - \frac{M}{jd \cdot A_{sc}} \quad (8)$$

$$f_{ten} = \frac{V \cdot \cot \varphi}{2 \cdot A_{st}} + \frac{M}{jd \cdot A_{st}} \quad (9)$$

where f_{com} : stress of upper longitudinal reinforcement, f_{ten} : stress of lower longitudinal reinforcement, V : shear force, A_{sc} : sectional area of upper longitudinal reinforcement, A_{st} : sectional area of lower longitudinal reinforcement, M : bending moment, jd : distance between upper and lower longitudinal reinforcements.

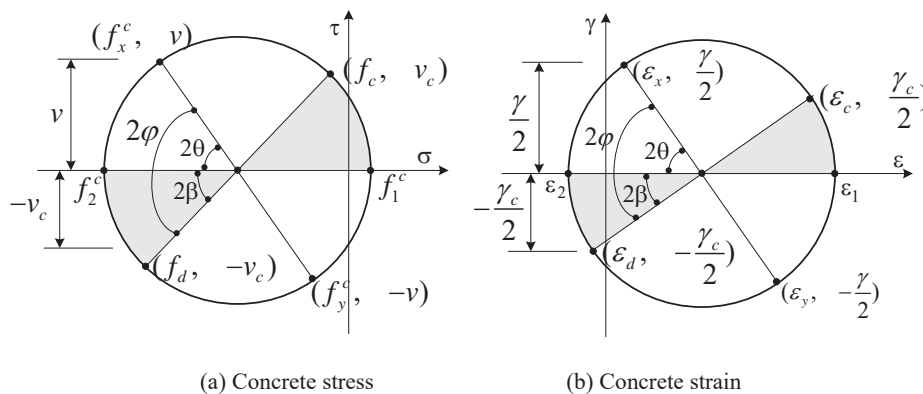

Fig. 2 Mohr's stress and strain circles of concrete

C. Compatibility Conditions

The smeared strain in the cracked reinforced concrete in the x-and y-directions, as shown in Fig. 2, results from the strains of concrete, ε_{x0} and ε_{y0} , and the strains due to crack opening and crack shear displacement as shown in (10) and (11) [14], [15].

$$\varepsilon_x = \varepsilon_{x0} + \varepsilon_{xw} + \varepsilon_{xv} \quad (10)$$

$$\varepsilon_y = \varepsilon_{y0} + \varepsilon_{yw} + \varepsilon_{yv} \quad (11)$$

where ε_x and ε_y : smeared strains in the cracked reinforced concrete in the x-and y-directions, respectively, ε_{x0} and ε_{y0} : strains of concrete in the x and y directions, respectively, ε_{xw} and ε_{yw} : smeared strains due to crack opening in the x-and y-directions, respectively, ε_{xv} and ε_{yv} : smeared strains due to crack shear displacement in the x-and y-directions, respectively,

The concrete strains, ε_{x0} and ε_{y0} , in the x-and y-directions can be derived from the principal strains of concrete as:

$$\varepsilon_{x0} = \varepsilon_1 \sin^2 \theta + \varepsilon_2 \cos^2 \theta \quad (12)$$

$$\varepsilon_{y0} = \varepsilon_1 \cos^2 \theta + \varepsilon_2 \sin^2 \theta \quad (13)$$

where ε_1 and ε_2 : principal tension and compression strains, respectively, θ : inclination of principal compressive stress.

The smeared uniaxial and shear strains of cracked concrete in x-and y-directions are expressed by (14) through (17).

$$\varepsilon_{xw} = \sin^2 \varphi \frac{w}{s_c} \quad (14)$$

$$\varepsilon_{yw} = \cos^2 \varphi \frac{w}{s_c} \quad (15)$$

$$\varepsilon_{xv} = -\sin \varphi \cdot \cos \varphi \frac{v}{s_c} \quad (16)$$

$$\varepsilon_{yv} = \sin \varphi \cdot \cos \varphi \frac{v}{s_c} \quad (17)$$

where, width of diagonal crack, v : crack shear displacement, s_c : average crack spacing.

D. Equation for Crack Widths

The smeared strains, w/s_c and v/s_c , due to diagonal cracks can be derived as shown in (18) and (19) by use of (10) through (17):

$$\frac{w}{s_c} = \varepsilon_x + \varepsilon_y - \varepsilon_{xv} - \varepsilon_{yv} \quad (18)$$

$$\frac{v}{s_c} = \varepsilon_y \tan \varphi - \varepsilon_x \cot \varphi - \varepsilon_1 \frac{\sin^2 \varphi - \sin^2 \theta}{\sin \varphi \cos \varphi} + \varepsilon_2 \frac{\cos^2 \varphi - \sin^2 \theta}{\sin \varphi \cos \varphi} \quad (19)$$

In the analysis, the centroidal axial strain at the shear critical section, ε_x , is the average values of the lower and upper longitudinal reinforcements as:

$$\varepsilon_x = \frac{\varepsilon_{com} + \varepsilon_{ten}}{2} \quad (20)$$

where ε_{com} and ε_{ten} : strain of upper and lower longitudinal reinforcements, respectively.

As shown in (19), the diagonal crack width, w , is closely related to the following five parameters: ε_x : average smeared strain of cracked concrete in span direction, ε_y : average smeared strain of cracked concrete in transverse direction, ε_1 : principal tensile strain of concrete, ε_2 : principal compressive strain of concrete, s_c : average crack spacing

III. ANALYSIS PREPARATION

A. Parameters

The diagonal crack width of RC members was estimated by simulating a compatibility aided truss model considering the effect of bending moment to the three parameters: shear reinforcement ratio, yield strength of shear reinforcement, and compressive strength of concrete. These variables are considered as the most important factors affecting the diagonal crack width. Three parameters are arranged as follows:

- 1) Shear reinforcement ratio, ρ_w : check the effect of ρ_w on the diagonal crack width for values of $0.2\% \leq \rho_w \leq 1.2\%$ (ρ_w increases by 0.1%)
- 2) Yield strength of shear reinforcement, f_{wy} : check the effect of f_{wy} on the diagonal crack width. The f_{wy} varies as $f_{wy} = 300$ MPa, 400 MPa, 800 MPa, and 1300 MPa.
- 3) Compressive strength of concrete, f_c' : check the effect of f_c' on the diagonal crack width. The f_c' varies as $f_c' = 24$ MPa, 36 MPa, 48 MPa, and 60 MPa.

B. Geometric and Material Properties

The geometric and material properties of the analyzed beams can be summarized as:

- 1) The sectional dimensions of the analyzed beams are 150 mm wide and 300 mm deep. The effective depth is 270 mm.
- 2) Tensile strength of concrete, f_{sp} , is determined by using the equation in CEB-FIP design code as given in (21). The value of f_{sp} is the function of the compressive strength of concrete.

$$f_{sp} = 0.607(f_c')^{2/3} \quad (21)$$

With respect to the spacing of diagonal crack, s_c , measured vertical in the direction of diagonal cracks, (22) was used.

$$\frac{1}{s_c} = 5 \frac{\rho_w}{d_s} + \frac{2}{jd} \quad (22)$$

where ρ_w : shear reinforcement ratio, d_s : distance of shear steel bar, jd : distance between upper and lower longitudinal reinforcements.

IV. ANALYSIS RESULTS

A. Effects of Shear Reinforcement Ratio on Diagonal Crack Widths

Figs. 3 and 4 show the effect of shear reinforcement, ρ_w , on the diagonal crack width by using the analytical model. The shear reinforcement, ρ_w , varied from 0.2% to 1.2%. In Figs. 3 and 4, x- and y- axes represent the shear reinforcement ratio and the shear stress, respectively. The figure illustrates the relationships of $V/(b \cdot jd)$ and ρ_w at the formation of diagonal crack with $w = 0.1$ mm, 0.2 mm, 0.3 mm, 0.4 mm, 0.5 mm, and at shear failure. Moreover, the values in the graph represent the shear crack width at the formation of diagonal shear crack and at shear failure.

From the figure, it can be seen that when the yield strength of shear reinforcement and the compressive strength of concrete are fixed, the diagonal shear crack width decreases with the increase of shear reinforcement ratio due to the restraint of the opening of shear crack for the same shear force. Further it is not surprising that the shear strength of the beam with small shear reinforcement ratio is lower than that of the beam with larger shear reinforcement ratio because the increase of shear crack width causes the decrease of stress transfer on the crack plane.

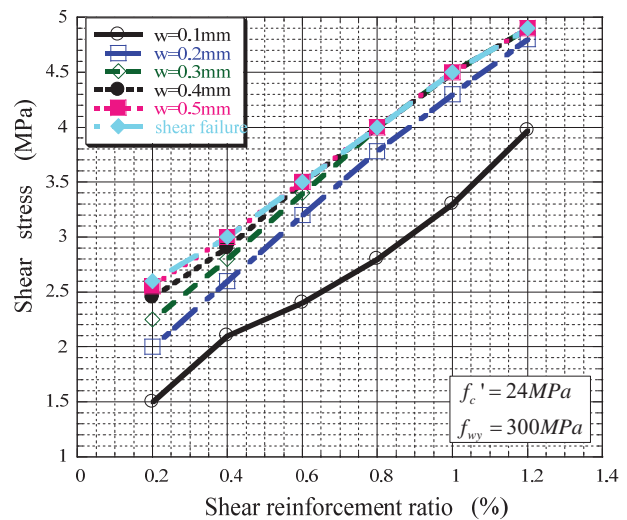

Fig. 3 Effect of shear reinforcement ratio for RC beams with $f_c' = 24$ MPa

B. Effects of the Yield Strength of Stirrups on Diagonal Crack Widths

Fig. 5 illustrates the effect of the yield strength of shear reinforcement, f_{wy} , on the diagonal shear crack predicted by applying (22). The yield strength of shear reinforcement, f_{wy} , varies as 300, 400, 800, and 1300 MPa. For the four analyzed beams, the shear reinforcement ratio and the compressive strength of concrete were the same as $\rho_w = 0.4\%$ and $f_c' = 24$ MPa, respectively. In the figure, the x- and y- axes represent the diagonal shear crack and the predicted shear strength, respectively. The open circle indicates the yield point of shear reinforcement.

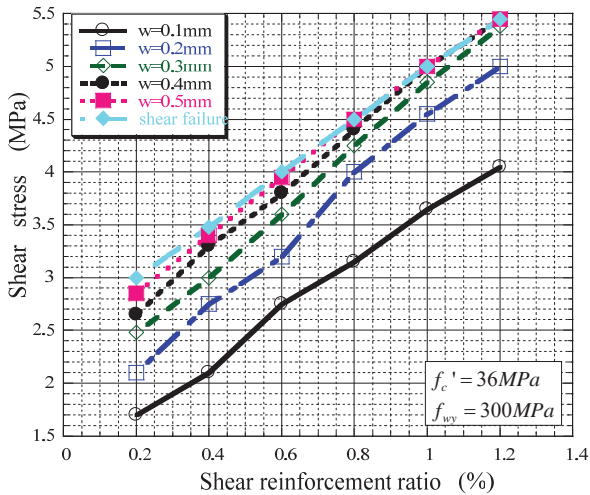

Fig. 4 Effect of shear reinforcement ratio for RC beams with $f'_c = 36 \text{ MPa}$

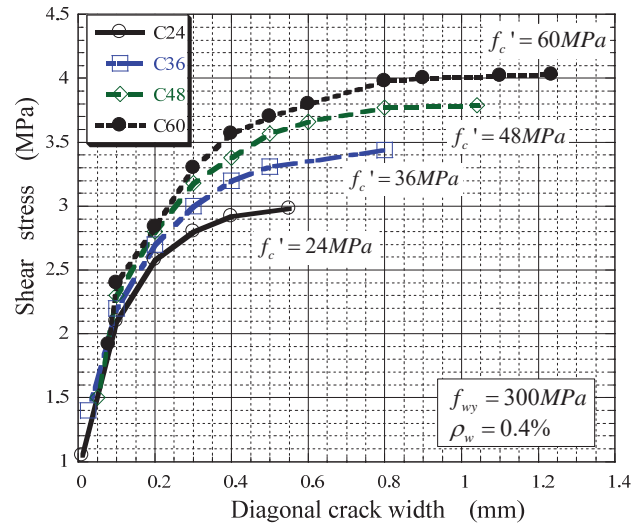

Fig. 6 Effect of compressive strength of concrete

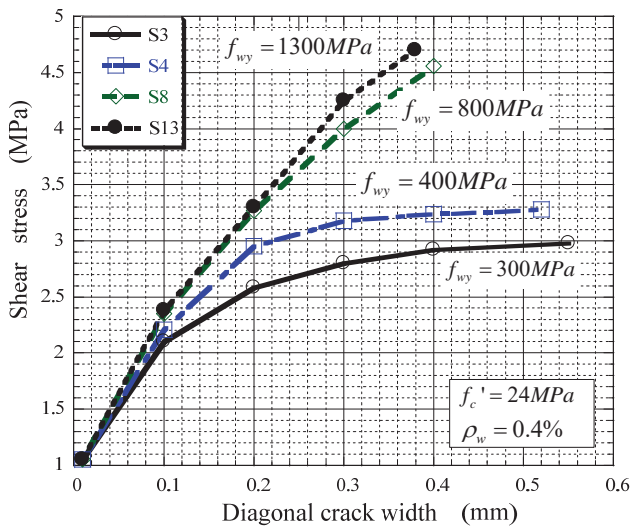

Fig. 5 Effect of yield strength of shear reinforcement

As can be seen from Fig. 5, it is clear that when the shear reinforcement ratio and the compressive strength of concrete are fixed, the shear crack width, w , decreases with the increase of the yield strength of shear reinforcement, f_{wy} , due to the restraint of the opening of shear crack for the same shear force. Furthermore, as can be known from the open circles, the shear reinforcing bars of S3 and S4C24P reach their yield strains at the crack width of $w \approx 0.16 \text{ mm}$ and $w \approx 0.22 \text{ mm}$, respectively. That is, the specimens S3 and S4 fail in shear due to excessive widening of shear cracks without a large increase of shear force after the yielding of shear reinforcement. On the other hand, for the specimens S8 and S13, it was not observed that the shear reinforcing bars reached their yield strains even up to the shear force. These two specimens fail due to concrete crushing before the yield of shear reinforcement.

The shear strength vs. diagonal crack width curves of four specimens might be the same up to the yield point of shear reinforcement. However, for the average stress-strain relationship of shear reinforcement, as the proposed analytical method takes into account the tension stiffening effect due to the surrounding concrete connected to the steel bars, the shear strength vs. diagonal crack width curves of four specimens were different one another when the shear reinforcement arrived at its yield strain.

C. Effects of the Compressive Strength of Concrete on Diagonal Crack Widths

Fig. 6 illustrates the effect of the compressive strength of concrete, f'_c , on the diagonal shear crack predicted by applying (22). The compressive strength of concrete, f'_c , varies as 24, 36, 48, and 60 MPa. With respect to the four analyzed beams, the shear reinforcement ratio and the yield strength of shear reinforcement were the same as $\rho_w = 0.4\%$ and $f_{wy} = 300 \text{ MPa}$, respectively. In the figure, the x- and y- axes represent the diagonal shear crack width and the predicted shear strength, respectively. From the figure, it can be noted that when the shear reinforcement ratio and the yield strength of shear reinforcement are fixed, the shear crack width, w , decreases with the increase of the compressive strength of concrete, f'_c , for the same shear force. Regarding the maximum shear crack width at shear failure; however, the diagonal shear crack width of the beam with high strength concrete is greater than that of the beam with normal strength concrete. The reason is that it is hard of the principal compressive stress of a beam with high strength concrete to attain the effective strength of concrete, vf'_c , since the effective strength of concrete increases proportionally to the value of f'_c .

V. CONCLUSIONS

In this study, the diagonal shear crack width of RC members with high strength materials were predicted by simulating a compatibility-aided truss model. The diagonal crack width was predicted by simulating the proposed analytical method varying

three parameters: shear reinforcement ratio, yield strength of shear reinforcement, and compressive strength of concrete. The analytical results can be summarized as:

- 1) The diagonal shear crack width decreased with the increase of the shear reinforcement ratio due to the restraint of the opening of shear crack when the yield strength of shear reinforcement and the compressive strength of concrete were fixed.
- 2) The yield strength of shear reinforcement and the compressive strength of concrete decreased the diagonal shear crack width for the same shear force because of the change of shear failure modes. However, regarding the maximum shear crack width at shear failure, the shear crack width of the beam with high strength materials was greater than that of the beam with normal strength materials.



Jung-Yoon Lee is a Professor in the School of Civil and Architectural Engineering at Sungkyunkwan University, Republic of Korea. He is involved in the committees, Shear and Torsion and Seismic Design, of the Korean Concrete Institute Committee. He has performed extensive research on the shear behavior and seismic design of reinforced and prestressed concrete buildings.



Hye-Sun Lim received his BS degree from SungKyunKwan University at Suwon, Republic of Korea in 2015. Her research interests include the shear behavior of prestressed concrete structure. She is in a master's degree course in the Dept. of Civil, Architectural and Environmental System Engineering at SungKyunKwan University, Republic of Korea.



Sung Hyun Yoon received his M.S. degree in architectural engineering from the Sungkyunkwan University, Suwon, Republic of Korea in 2003. His research interest includes shear and torsional behavior on reinforced concrete structures. He is in the doctor's course in the Dept. of Civil, Architectural and Environmental System Engineering at Sungkyunkwan University, Republic.

ACKNOWLEDGMENT

This research was supported by Basic Science Research Program through the National Research Foundation of Korea (NRF) funded by the Ministry of Education (grant number: 2015R1D1A1A01056612).

REFERENCES

- [1] A. Munikrishna, A. Hosny, S. Rizkalla, and Zia, P., "Behavior of Concrete Beams Reinforced with ASTM A1035 Grade 100 Stirrups Under Shear," *ACI Structural Journal*, vol. 108, no. 4, pp.34-41, 2011.
- [2] A. Hosny, H. M. Seliem, S. Rizkalla, and P. Zia, "Development Length of Unconfined Conventional and High-Strength Steel Reinforcing Bars," *ACI Structural Journal*, vol. 109, no. 5, pp.655-664, 2012.
- [3] H. Aoyama, *Design of Modern Highrise Reinforced Concrete Structures*, Imperial College Press, 2001, 442pp.
- [4] ACI Committee 318-11, *Building Code Requirements for Structural Concrete and Commentary (ACI 318-11)*, American Concrete Institute, Detroit: USA, 2011, 503pp.
- [5] J.-Y. Lee and I.-J. Choi, "Shear Behavior of Reinforced Concrete Beams with High-Strength Stirrups," *ACI Structural Journal*, vol.108, no.5, 2011, pp. 620-629.
- [6] P.L. Regan and A.L.L. Baker, "Shear Failure of Reinforced Concrete Beams," *ACI Structural Journal*, vol.68, no.10, 1971, pp.763-773.
- [7] D. Michell and M.P. Collins, *Prestressed Concrete Structures*, Prentice Hall, 1990, pp. 624-635.
- [8] Comite European De Normalisation(CEN), *Eurocode 2: Design of Concrete Structures, Part 1-1 General Rules and Rules for Buildings*, BS EN 1992-1-1, 2004, 211pp.
- [9] W. Ritter, "Die Bauweise Hennebique," *Schweizerische Bauzeitung*, vol. 33, no. 7. 1899, pp. 59-61.
- [10] E. Moersch, *Der Eisenbetonbau, Seine Theorie Und Anwendung*, Stuttgart, German: K. Wittwer; 1922.
- [11] M.P. Nielsen, "Om forskydningsarmering i jernbetonbjae lker," *Bygningsstat, Medd.*, vol. 38, no. 2, 1967, pp.33-58.
- [12] Architectural Institute of Japan (AIJ), *Design Guidelines for Earthquake-Resistant Reinforced Concrete Buildings Based on Ultimate Strength Concept*, Architectural Institute of Japan, 1990.
- [13] T.T.C. Hsu, "Softened Truss Model Theory for Shear and Torsion," *ACI Structural Journal*, vol. 85, no. 6. 1988, pp. 624-35.
- [14] J.-Y. Lee, *Theoretical Prediction of Shear Behavior and Ductility of Reinforced Concrete Beams*, PhD dissertation, Kyoto University, Japan, 1998.
- [15] H. Kupfer and H. Bulicek, "A Consistent Model for the Design of Shear Reinforcement in Slender Beams with I- or Box-shaped Cross Section," *International Workshop on Concrete Shear in Earthquake*, Houston, USA, 1991, pp. 256-265.