

# $k$ -Neighborhood Template $\mathcal{A}$ -Type Three-Dimensional Bounded Cellular Acceptor

Makoto Nagatomo, Yasuo Uchida, Makoto Sakamoto, Tuo Zhang, Tatsuma Kurogi, Takao Ito, Tsunehiro Yoshinaga, Satoshi Ikeda, Masahiro Yokomichi, Hiroshi Furutani

**Abstract**—This paper presents a four-dimensional computational model,  $k$ -neighborhood template  $\mathcal{A}$ -type three-dimensional bounded cellular acceptor (abbreviated as  $\mathcal{A}$ -3BCA( $k$ )), and discusses the hierarchical properties. An  $\mathcal{A}$ -3BCA( $k$ ) is a four-dimensional automaton which consists of a pair of a converter and a configuration-reader. The former converts the given four-dimensional tape to the three- and two-dimensional configuration and the latter determines the acceptance or nonacceptance of given four-dimensional tape whether or not the derived two-dimensional configuration is accepted. We mainly investigate the difference of the accepting power based on the difference of the configuration-reader. It is shown that the difference of the accepting power of the configuration-reader tends to affect directly that of the  $\mathcal{A}$ -3BCA( $k$ ) for the case when the converter is deterministic. On the other hand, results are not analogous for the nondeterministic case.

**Keywords**—Cellular acceptor, configuration-reader, converter, finite automaton, four-dimension, on-line tessellation acceptor, parallel/sequential array acceptor, turing machine.

## I. INTRODUCTION AND PRELIMINARIES

THE growth of the the processing of pictorial information by computer was rapid in 1960's. Therefore, the problem of computational complexity was also arisen in the two-dimensional information processing. Blum and Hewitt first proposed two-dimensional automata as a computational model of two-dimensional pattern processing, and investigated their pattern recognition abilities [1]. Many researchers in this field have investigated the properties of automata on a two- or three-dimensional tape since their paper was presented [2], [3], [8]-[30]. On the other hand, the question of whether processing four-dimensional digital patterns is more difficult than processing two- or three-dimensional ones is of great interest from both theoretical and practical standpoints. Thus, the study of four-dimensional automata as the computational model of four-dimensional pattern processing has been meaningful. From this point of view, we are interested in four-dimensional automata [21], [22]. In the multi-dimensional pattern processing, designers often use a strategy whereby features are extracted by projecting high-dimensional space on low-dimensional space.

In this paper, from this viewpoint, we present a computational model,  $k$ -neighborhood template  $\mathcal{A}$ -type three-dimensional bounded cellular acceptor (abbreviated as  $\mathcal{A}$ -3BCA( $k$ )) on four-dimensional tapes, and discuss some basic properties.

M. Sakamoto, M. Nagatomo, T. Zhang, T. Kurogi, S. Ikeda, M. Yokomichi, and H. Furutani are with University of Miyazaki, Miyazaki, Miyazaki 889-2192, Japan (e-mail:sakamoto@cs.miyazaki-u.ac.jp).

Y. Uchida and T. Ito are with Ube National College of Technology, Ube, Yamaguchi 755-8555, Japan.

T. Yoshinaga is with Tokuyama College of Technology, Shunan, Yamaguchi 745-8585, Japan.

An  $\mathcal{A}$ -3BCA( $k$ ) consists of a pair of a *converter* and a *configuration-reader*. The former converts the given four-dimensional tape to the three- and two-dimensional configuration and the latter determines the acceptance or nonacceptance of given four-dimensional tape whether or not the derived two-dimensional configuration is accepted [22], [25]. When an input four-dimensional tape is presented to the  $\mathcal{A}$ -3BCA( $k$ ), a three-dimensional cellular automaton as the converter first reads it to the future direction at unit speed (i.e., one three-dimensional rectangular array per unit time), and a two-dimensional cellular automaton as the converter next reads a converted three-dimensional configuration downward at unit speed (i.e., one plane per unit time). From this process, the four-dimensional tape is converted to a configuration of the converter which is a state matrix of a two-dimensional cellular automaton. Second, two-dimensional automaton as the configuration-reader, reads the configuration and determines its acceptance. We say that an input four-dimensional tape is accepted by the  $\mathcal{A}$ -3BCA( $k$ ) if and only if the configuration is accepted by the configuration-reader. Therefore, the accepting power of the  $\mathcal{A}$ -3BCA( $k$ ) depends on how to combine the converter and the configuration-reader.

An  $\mathcal{A}$ -3DBCA( $k$ ) ( $\mathcal{A}$ -3NBCA( $k$ )) is called a  $k$ -neighborhood template  $\mathcal{A}$ -type three-dimensional deterministic bounded cellular acceptor ( $k$ -neighborhood template  $\mathcal{A}$ -type three-dimensional nondeterministic bounded cellular acceptor). A DA [1] ( $NA$ ,  $DB$  [23],  $NB$ ,  $DO$  [6],  $NO$ ,  $DOP$  [5], [16],  $NOP$ ,  $DP$  [5], [16],  $NP$ ,  $DTM$  [4], [9],  $NTM$ ) is called a two-dimensional deterministic finite automaton (two-dimensional nondeterministic finite automaton, deterministic one-dimensional bounded cellular acceptor, nondeterministic one-dimensional bounded cellular acceptor, two-dimensional deterministic on-line tessellation acceptor, two-dimensional nondeterministic on-line tessellation acceptor, deterministic one-way parallel/sequential array acceptor, nondeterministic one-way parallel/sequential array acceptor, deterministic two-way parallel/sequential array acceptor, nondeterministic two-way parallel/sequential array acceptor, two-dimensional deterministic Turing machine, two-dimensional nondeterministic Turing machine). Let  $T(M)$  be the set of four-dimensional tapes accepted by a machine  $M$ , and let  $\mathcal{L}(\mathcal{A}$ -3DBCA( $k$ )) =  $\{T|T=T(M)$  for some  $\mathcal{A}$ -3DBCA( $k$ )  $M\}$ .  $\mathcal{L}(\mathcal{A}$ -3NBCA( $k$ )), etc. are defined in the same way as  $\mathcal{L}(\mathcal{A}$ -3DBCA( $k$ )).

Let  $\Sigma$  be a finite set of symbols. A *four-dimensional tape* over  $\Sigma$  is a four-dimensional rectangular array of elements of  $\Sigma$ . The set of all four-dimensional tapes over  $\Sigma$  is denoted by  $\Sigma^{(4)}$ . Given a tape  $x \in \Sigma^{(4)}$ , for each integer  $j(1 \leq j \leq$

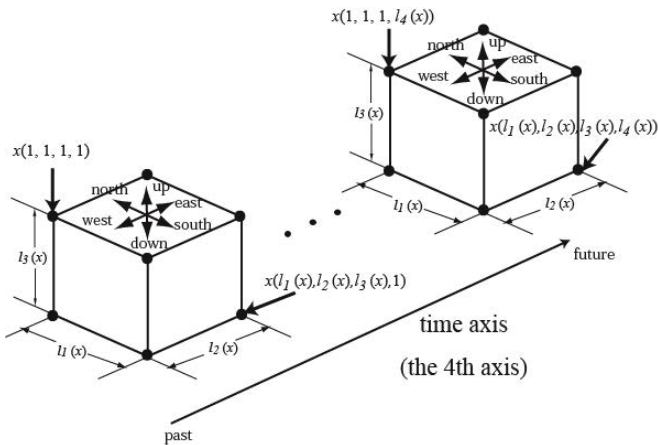

Fig. 1 Four-dimensional Input Tape

4), we let  $l_j(x)$  be the length of  $x$  along the  $j$ th axis. The set of all  $x \in \sum^{(4)}$  with  $l_1(x) = n_1, l_2(x) = n_2, l_3(x) = n_3,$  and  $l_4(x) = n_4$  is denoted by  $\sum^{(n_1, n_2, n_3, n_4)}$ . When  $1 \leq i_j \leq l_j(x)$  for each  $j(1 \leq j \leq 4)$ , let  $x(i_1, i_2, i_3, i_4)$  denote the symbol in  $x$  with coordinates  $(i_1, i_2, i_3, i_4)$ , as shown in Fig. 1. Furthermore, we define

$$x[(i_1, i_2, i_3, i_4), (i'_1, i'_2, i'_3, i'_4)],$$

when  $1 \leq i_j \leq i'_j \leq l_j(x)$  for each integer  $j(1 \leq j \leq 4)$ , as the four-dimensional input tape  $y$  satisfying the following conditions:

- (i) for each  $j(1 \leq j \leq 4), l_j(y) = i'_j - i_j + 1;$
- (ii) for each  $r_1, r_2, r_3, r_4(1 \leq r_1 \leq l_1(y), 1 \leq r_2 \leq l_2(y), 1 \leq r_3 \leq l_3(y), 1 \leq r_4 \leq l_4(y)), y(r_1, r_2, r_3, r_4) = x(r_1 + i_1 - 1, r_2 + i_2 - 1, r_3 + i_3 - 1, r_4 + i_4 - 1).$  (We call  $x[(i_1, i_2, i_3, i_4), (i'_1, i'_2, i'_3, i'_4)]$  the  $[(i_1, i_2, i_3, i_4), (i'_1, i'_2, i'_3, i'_4)]$ -segment of  $x$ .)

We let each sidelength of each input tape of these automata be equivalent in order to increase the theoretical interest.

## II. MAIN RESULTS

This section investigates how the difference of configuration-reader affects the accepting powers of  $A-3BCA(k)$ 's. First, we start to investigate the case when the converter is deterministic.

**Lemma 1.** Let  $T_1 = \{x \in \{0,1,2\}^{(4)} \mid \exists n \geq 1 [l_1(x) = l_2(x) = l_3(x) = l_4(x) = n+1 \ \& \ \exists i(1 \leq i \leq n)[x(i, n+1, n+1, n+1) = 2 \ \& \ (\text{each symbol on the remaining parts is "0" or "1"}) \ \& \ x[(i, 1, n+1, n+1), (i, n, n+1, n+1)] \neq x[(n+1, 1, n+1, n+1), (n+1, n, n+1, n+1)]]\}$ . Then,

- (1)  $T_1 \in \mathcal{L}(NA-3DBCA(1)),$
- (2)  $T_1 \notin \mathcal{L}(DA-3DBCA(9)).$

**Proof:** It is easily seen that there exists a nondeterministic two-dimensional finite automaton accepting the set of two-dimensional tapes which are obtained by extracting the bottom plane from the tape contained in  $T_1$ . Therefore, (1)

holds. On the other hand, the proof of (2) is similar to that of Lemma 2(2) in [1].  $\square$

**Lemma 2.** Let  $T_2 = \{x \in \{0,1\}^{(4)} \mid \exists n \geq 1 [l_1(x) = l_2(x) = l_3(x) = l_4(x) = 2n \ \& \ x[(1,1,2n,2n), (2n,n,2n,2n)] = x[(1,n+1,2n,2n), (2n,2n,2n,2n)]]\}$ . Then,

- (1)  $T_2 \in \mathcal{L}(DOP-3DBCA(1)),$
- (2)  $T_2 \notin \mathcal{L}(NO-3DBCA(9)).$

**Proof:** (1) Note that there exists a deterministic one-way parallel sequential array acceptor accepting the set of two-dimensional tapes obtained by extracting the bottom plane of the last cube from the tape contained in  $T_2$  [7]. It is easily seen from this fact that (1) holds. (2) The proof is similar to that of Lemma 2(1). Suppose that there exists an  $NO-3DBCA(9)$   $M = (R, B)$  accepting  $T_2$ . Let  $K$  be the set of each cell of  $B \in NO$ , and  $|K| = s$ .

For each  $n \geq 1$ , let  $V(n) = \{x \in \{0,1\}^{(4)} \mid l_1(x) = l_2(x) = l_3(x) = l_4(x) = 2n \ \& \ x[(1,1,1,1), (2n, 2n, 2n, 2n-1)] \in \{0\}^{(4)}\}$ ,  $V'(n) = V(n) \cap T_2$ ,  $W(n) = \{w \in K^{(2)+} \mid l_1(w) = 2n \ \& \ l_2(w) = 1\}$  ( $K^{(2)}$  means the set of all two-dimensional tapes over  $\sum$ ). For each  $x \in V(n)$ , let  $\rho(x) \equiv$  the configuration of  $R$  just after reading  $x$ ,  $\rho_W(x) \equiv$  the west half of  $\rho(x)$ , and  $\rho_E(x) \equiv$  the east half of  $\rho(x)$ . Further, for each  $x \in V'(n)$ , let  $\text{Run}(x) = \{z \in K^{(2)} \mid z \text{ is a run of } B \text{ on } \rho(x) \text{ whose lower right corner symbol is an accepting state of } B.\}$  and  $r(x) = \{z[(1,n,2n,2n), (2n,n,2n,2n)] \mid z \in \text{Run}(x)\} \subseteq W(n)$ . Then, the following proposition must hold.

**Proposition 1.** For any two different tapes  $x$  and  $y$  in  $V'(n)$ ,  $r(x) \cap r(y) = \phi$ .

**Proof:** The proof is similar to that of Proposition 4. in [27]

**Proof of Lemma 2 (continued):** As is easily seen,

$$|V'(n)| = 2^{2n^2} \text{ and } |W(n)| \leq s^{2n}.$$

Therefore, it follows for large  $n$  that

$$|V'(n)| > |W(n)|.$$

Consequently, ii follows for such large  $n$  that there must be two different tapes  $x$  and  $y$  in  $V'(n)$  such that  $r(x) \cap r(y) \neq \phi$ . This contradicts Proposition 1.  $\square$

**Lemma 3.** Let  $T_3 = \{x \in \{0,1\}^{(4)} \mid \exists n \geq 1 [l_1(x) = l_2(x) = l_3(x) = l_4(x) = 2n \ \& \ x[(1,1,2n,2n), (n,2n,2n,2n)] = x[(n+1,1,2n,2n), (2n,2n,2n,2n)]]\}$ . Then,

- (1)  $T_3 \in \mathcal{L}(DP-3DBCA(1)),$
- (2)  $T_3 \notin \mathcal{L}(NOP-3DBCA(9)).$

**Proof:** (1) Note that [7] there exists a deterministic two-way parallel sequential array acceptor accepting the set of two-dimensional tapes which are obtained by extracting the bottom plane of the last cube from the tape contained in  $T_3$ . It is easily seen, from this fact, that (1) holds.

(2) Suppose that there exists an  $NOP-3DBCA(9)$   $M = \{R, B\}$  accepting  $T_3$ . Let  $s$  be the number of states of each cell of  $B \in NOP$ . For each  $n \geq 1$ , let  $V(n) = \{x \in \{0,1\}^{(4)} \mid l_1(x) = l_2(x) = l_3(x) = l_4(x) = 2n \ \& \ x[(1,1,1,1), (2n,2n,2n,2n-1)] \in \{0\}^{(4)}\}$ ,  $V'(n) = V(n) \cap T_3$ . For each  $x \in V(n)$ , let  $\rho(x) \equiv$  the configuration of  $R$  just after reading  $x$ ,  $\rho_N(x) \equiv$  the north half of  $\rho(x)$ , and  $\rho_S(x) \equiv$  the south half of

$\rho(x)$ . Furthermore, for each  $x \in V'(n)$ , let  $\text{conf}(x) \equiv$  the set of possible configuration of  $B$  just after  $\rho_N(x)$  is read, when  $\rho(x)$  is accepted by  $B$ . (Note that  $\rho(x)$  is accepted by  $B$  since each tape in  $V'(n)$  is accepted by  $M$ .) Then, the following two propositions must hold. (The proofs are omitted here. If necessary, see proofs of Lemmas 7 and 8 in [26].)

**Proposition 2.**

- (i) For any two tapes  $x$  and  $y$  in  $V'(n)$  such that their  $[(1, 1, 2n, 2n), (n, 2n, 2n, 2n)]$ -segments are identical,  $\rho_N(x) = \rho_N(y)$ .
- (ii) For any two tapes  $x$  and  $y$  in  $V'(n)$  such that their  $[(n+1, 1, 2n, 2n), (2n, 2n, 2n, 2n)]$ -segments are identical,  $\rho_S(x) = \rho_S(y)$ .

**Proposition 3.** For any two different tapes  $x$  and  $y$  in  $V'(n)$ ,  $\text{conf}(x) \cap \text{conf}(y) = \phi$ .

**Proof of Lemma 3 (continued):** As is easily seen,

$$|V'(n)| = 2^{2n^2}.$$

Let  $t(n)$  be the total number of different configurations of  $R$  just after reading north halves of configurations of  $R$  just after reading tapes in  $V'(n)$ . Clearly,

$$t(n) \leq s^{2n}.$$

Therefore, it follows for large  $n$  that

$$|V'(n)| > t(n).$$

Consequently, it follows for such large  $n$  that there must be two different tapes  $x$  and  $y$  in  $V'(n)$  such that  $\text{conf}(x) \cap \text{conf}(y) \neq \phi$ . This contradicts Proposition 3.  $\square$

**Lemma 4.** Let  $T_4$  be the set of three-dimensional tapes described in Lemma 1 in [1]. Then,

- (1)  $T_4 \in \mathcal{L}(NB-3DBCA(1))$ ,
- (2)  $T_4 \notin \mathcal{L}(DOP-3DBCA(9))$ .

**Proof:** (1) It is easily seen that there exists a nondeterministic one-dimensional bounded cellular automaton accepting the set of two-dimensional tapes which are obtained by attracting the bottom plane from the tape contained in  $T_4$ . Therefore, (1) holds. On the other hand, the proof of (2) is shown from Lemma 1 in [1].  $\square$

**Lemma 5.** Let  $T_5 = \{x \in \{0,1\}^{(4)} \mid \exists n \geq 1 [l_1(x) = l_2(x) = l_3(x) = l_4(x) = 2n \ \& \ [x(1,1,2n,2n), (n,n,2n,2n)] \neq x[(n+1,n+1,2n,2n), (2n,2n,2n,2n)]]\}$ . Then,

- (1)  $T_5 \in \mathcal{L}(NB-3DBCA(1))$ ,
- (2)  $T_5 \notin \mathcal{L}(NA-3DBCA(9))$ .

**Proof:** (1) It is easily seen that there exists a nondeterministic one-dimensional bounded cellular automaton accepting the set of two-dimensional tapes which are obtained by extracting the bottom plane from the tape contained in  $T_5$ . Therefore, (1) holds. On the other hand, the proof of (2) is similar to that of Lemma 2 in [1].  $\square$

From the foregoing lemmas, we can obtain the following theorem when the converter is deterministic.

**Theorem 1.** For each  $k \in \{1, 5, 9\}$ ,

- (1)  $\mathcal{L}(DA-3DBCA(k)) \subsetneq \mathcal{L}(NA-3DBCA(k)) \subsetneq \mathcal{L}(NB-3DBCA(k)) = \mathcal{L}(NO-3DBCA(k)) \subsetneq \mathcal{L}(NOP-3DBCA(k)) \subsetneq \mathcal{L}(NP-3DBCA(k))$ ,

- (2)  $\mathcal{L}(DB-3DBCA(k)) \subsetneq \mathcal{L}(NB-3DBCA(k))$ ,
- (3)  $\mathcal{L}(DO-3DBCA(k)) \subsetneq \mathcal{L}(NO-3DBCA(k))$ ,
- (4)  $\mathcal{L}(DB-3DBCA(k)) \subsetneq \mathcal{L}(DOP-3DBCA(k)) \subsetneq \mathcal{L}(DP-3DBCA(k))$ ,
- (5)  $\mathcal{L}(DO-3DBCA(k)) \subsetneq \mathcal{L}(DOP-3DBCA(k)) \subsetneq \mathcal{L}(NOP-3DBCA(k))$ .

**Proof:** It is clear from Proposition 1 in [1] that the inclusion relations hold. Therefore, below, we show that the proper inclusion relations held for each  $k \in \{1,5,9\}$ .

(1): It is obvious from Proposition 1 in [1] that  $\mathcal{L}(NB-3DBCA(k)) = \mathcal{L}(NO-3DBCA(k))$ . From Lemma 1,  $\mathcal{L}(DA-3DBCA(k)) \subsetneq \mathcal{L}(NB-3DBCA(k))$  holds, and from Lemma 5,  $\mathcal{L}(NB-3DBCA(k)) \subsetneq \mathcal{L}(NOP-3DBCA(k))$  holds. In addition, it is obvious from Proposition 1 in [1] that  $\mathcal{L}(DOP-3DBCA(k)) \subseteq \mathcal{L}(NP-3DBCA(k))$ . It follows from this and Lemma 2 that  $\mathcal{L}(NO-3DBCA(k)) \subsetneq \mathcal{L}(NOP-3DBCA(k))$  holds. Further, it is also obvious from Proposition 1 in [1] that  $\mathcal{L}(DP-3DBCA(k)) \subseteq \mathcal{L}(NP-3DBCA(k))$ . It follows from this and Lemma 3 that  $\mathcal{L}(NOP-3DBCA(k)) \subsetneq \mathcal{L}(NP-3DBCA(k))$  holds.

(2) and (3): These are easily proved from Lemma 4 and Proposition 1 in [1].

(4) and (5): These are also easily proved from Lemmas 4,5,6 and Proposition 1 in [1].  $\square$

Next, we investigate the case when the converter is nondeterministic.

**Lemma 6.** For each  $k \in \{1,5,9\}$ ,

- (1)  $\mathcal{L}(NO-3NBCA(k)) \subseteq \mathcal{L}(DA-3NBCA(k))$ ,
- (2)  $\mathcal{L}(NO-3NBCA(k)) \subseteq \mathcal{L}(DB-3NBCA(k))$ ,
- (3)  $\mathcal{L}(NO-3NBCA(k)) \subseteq \mathcal{L}(DO-3NBCA(k))$ .

**Proof:** (1) We prove only  $\mathcal{L}(NO-3NBCA(1))$  (The other cases are proved similarly.) Let  $M = (R, B)$  be an arbitrary  $NO-3NBCA(1)$ , and let  $K_R$  and  $K_B$  be the set of states of  $R$  and  $B$ , respectively. Further, let  $M' = (R', B')$  be a  $DO-3NBCA(1)$  which acts as follows for a given four-dimensional tape  $x$  with each sidelength is  $n$  ( $n \geq 1$ ).

(i) Actions of the converter  $R'$

At each time, each  $(i, j, k, l)$ -cell ( $1 \leq i, j, k, l, \leq n$ ) of  $R'$  simulates the action of the corresponding cell of  $R$  on  $x$  at the same time. In parallel to this action, the cell selects nondeterministically a state in  $K_B$  (we let  $q(i, j, k, l)$  be the state) and stores the state in its state, when the cell reads a symbol on the top plane of the first cube of  $x$ . Here,  $q(i, j, k, l)$  is a guessed state of  $B$  which the  $(i, j, k, l)$ -cell of  $B$  will enter by reading the configuration of  $R$  just after reading  $x$ ;  $q(i, j, k, l)$  will have been stored in the state of the cell until  $x$  is completed to read.

(ii) Actions of the configuration reader  $B'$

For each  $i, j, k, l$  ( $1 \leq i, j, k, l \leq n$ ), let  $\rho(i, j, k, l)$  be a state in  $K_R$  which the  $(i, j, k, l)$ -cell of  $R'$  continues to simulate the action of corresponding cell of  $R$  and enters.  $B'$  accepts a configuration of  $R'$  just after reading  $x$  if and only if the following two conditions are satisfied.

- ① For each  $i, j, k, l$  ( $1 \leq i, j, k, l \leq n$ ), the  $(i, j, k, l)$ -cell can enter  $q(i, j, k, l)$  when it reads  $\rho(i, j, k, l)$ .
- ②  $q(n, n, n, n)$  is an accepting state of  $B$ .

It is easily seen that  $T(M') = T(M)$  for  $M = (R', B')$ . This completes the proof of the lemma.  $\square$

**Remark 1.** Lemma 6 has been proved by using a property such that not a cell of the two-dimensional on-line tessellation acceptor makes two of more state transitions. That is, its state-transition is guessed first by the converter nondeterministically, and then the configuration-reader checks whether or not this guess is correct. Therefore, the same idea as in the proof of Lemma 6 cannot apply directly to whether or not for each  $K \in \{1, 5, 9\}$ ,  $\mathcal{L}(NOP-3NBCA(k)) \subseteq \mathcal{L}(DO-3NBCA(k))$ , and so on. However, we can show by using this idea that for each  $k \in \{1, 5, 9\}$ ,  $\mathcal{L}(NOPL-3NBCA(k)) \in \mathcal{L}(DO-3NBCA(k))$ , where we let *NOPL* be the class of nondeterministic one-way parallel sequential array acceptors which operate on each row at most constant time.

From Lemma 6 and from Proposition 1 in [1], we can obtain directly the following theorem when the converter is nondeterministic. (The proof is omitted here.) It is of great interest to compare the following Theorem 2 with Theorem 1 mentioned for the deterministic case.

**Theorem 2.** For each  $k \in \{1, 5, 9\}$ ,  
 $\mathcal{L}(DA-3NBCA(k)) = \mathcal{L}(NA-3NBCA(k)) =$   
 $\mathcal{L}(DB-3NBCA(k)) = \mathcal{L}(NB-3NBCA(k)) =$   
 $\mathcal{L}(DO-3NBCA(k)) = \mathcal{L}(NO-3NBCA(k))$

### III. CONCLUSION

In this paper, we have investigated how the difference of neighborhood template of the converter or the configuration-reader affects the accepting powers of  $k$ -neighborhood template  $\mathcal{A}$ -type three-dimensional bounded cellular acceptor (abbreviated as  $\mathcal{A}$ -3BCA( $k$ )). Generally speaking, when the converter is deterministic, the accepting power of the  $\mathcal{A}$ -3BCA( $k$ ) tends to be more powerful as the number of neighborhood cells of the converter increases or the accepting power of the configuration-reader is more powerful. However, this tendency is not always true when the converter is nondeterministic.

We will attempt to compare the results in this paper with those for the  $(k, l)$ -neighborhood template  $\mathcal{A}$ -type bounded cellular acceptor ( $\mathcal{A}$ -BCA( $k, l$ )) operating on two-dimensional tapes to inspect whether or not this tendency is a property of  $\mathcal{A}$ -3BCA( $k$ ). Especially, we concentrate on determining when the converter is nondeterministic.

While the five-neighbor can simulate any neighbor for the four-dimensional case, (1,0)- or (9,1)-neighbor is such a neighbor for the two-dimensional case. In addition, for the two-dimensional case, it is shown that the accepting powers of the  $\mathcal{A}$ -BCA( $k, l$ ) has a neighborhood template except (0,0). On the other hand, in this paper, we show that not only five-neighbor and nine-neighbor but also one-neighbor has the forementioned property. The one-neighbor is a neighborhood template without communication with others. From this viewpoint, this theorem is of great interest.

By the way, tape sets from  $T_1$  to  $T_5$  used in this paper are sets of four-dimensional tapes which are obtained

by embedding well-known two-dimensional tapes to their bottom planes of the last cubes. Therefore, it seems to be obvious for the reader that lemmas using these tape sets hold. However, we emphasize that these lemmas are never derived immediately from the results on two-dimensional case. Even if it is well known that the set of bottom planes of the last cubes are not accepted by these cubic tapes may be accepted by an  $\mathcal{A}$ -3BCA( $k$ ) using the foregoing two-dimensional automaton as the configuration-reader. This fact follows since the configuration-reader can have the same operating time as the side-length of four-dimensional tapes. Now consider, for example, the set of all two-dimensional tapes whose center symbol is "1." It is well known in [1] that the set is not accepted by any two-dimensional deterministic finite automaton. However, it is easily seen that the set of four-dimensional tapes embedded the two-dimensional tapes to the bottom planes of the last cube accepted by a  $DA-3DBC(A(5))$ .

Further, although we can show only that five-neighbor is more powerful than one-neighbor, by using the accepting powers of two-dimensional automata as a complexity measures, this paper in fact estimates how different are the accepting powers between one-neighbor and five-neighbor. Since we can show that there exists a set of four-dimensional tapes accepting by a  $DA-3DBC(A(5))$  but not by any  $DTM-3DBC(A(1))$ , it follows that the difference between the accepting powers of one-neighbor and five-neighbor is so great that it cannot be measured by the accepting powers of two-dimensional automata. Similarly, it is easily seen that the difference between the accepting powers of five-neighbor and nine-neighbor is not less than  $\log n$  which is measured by the tape amount of nondeterministic tape-bounded two-dimensional Turing machines.

We conclude this paper by giving a few open problems.

- (1) For each  $\mathcal{A} \in \{DOP, NOP, DP, NP, DTM, NTM\}$ ,  $\mathcal{L}(\mathcal{A}-3DBC(A(5))) \subsetneq \mathcal{L}(\mathcal{A}-3DBC(A(9)))$ ?
- (2)  $\mathcal{L}(NO-3NBCA(5)) \subsetneq \mathcal{L}(DOP-3NBCA(5))$ ?

### REFERENCES

- [1] M.Blum and C.Hewitt, "Automata on a two-dimensional tape", IEEE Symposium on Switching and Automata Theory, pp.155-160, 1967.
- [2] M.Blum and W.J. Sakoda, "On the capability of finite automata in 2 and 3 dimensional spaces", Proceedings of the 18th Annual Symposium on Foundations of Computer Sciences, pp.147-161, 1977.
- [3] P.Dietz and S.R. Kosaraju, "Recognition of topological equivalence of patterns by array automata", Journal of Computer and System Sciences, 2, PP.111-116, 1980.
- [4] F.C Hennie, "One-tape off-line Turing machine computations", Information and Control, 8(6), pp.533-578, 1965.
- [5] K.Inoue and A.Nakamura, "Some notes on parallel sequential array acceptors", The Transactions of the IECE, Japan, J58-D(3), pp.167-169, 1975.
- [6] K.Inoue and A.Nakamura, "An  $n$ -dimensional on-line tessellation acceptor", The Transactions of the IECE, Japan, J59-D(4), pp.299-236, 1976.
- [7] K.Inoue, I.Takanami and H.Taniguchi, "The accepting powers of two-dimensional automata over square tapes", The Transactions of the IECE, Japan, J63-D(2), pp.113-120, 1980.
- [8] K.Inoue and I.Takanami, "A survey of two-dimensional automata theory", Information Sciences, 55, pp.99-121, 1991.
- [9] A.Ito, K.Inoue, and I.Takanami, "A note on three-way two-dimensional alternating Turing machine", Information Sciences, 45, pp. 1-22, 1988.

- [10] A.Ito, K.Inoue, I.Takanami, and Y. Wang, "The effect of inkdots for two-dimensional automata", *International Journal of Pattern Recognition and Artificial Intelligence*, 9(5), pp.777-796, 1995.
- [11] T.Ito, M.Sakamoto, N.Tomozoe, K.Iihoshi, H.Furutani, M.Kono, T.Tamaki, and K.Inoue, "Two-topics concerning three-dimensional synchronized alternating Turing machines", *WSEAS Transactions on Computers*, 10(5), pp.2149-2155, 2006.
- [12] T.Ito and M.Sakamoto, "Some accepting powers of three-dimensional synchronized alternating Turing machines", *Journal of Engineering, Computing and Architecture, Scientific Journals International*, 1(1), pp.1-11, 2007.
- [13] D.G. Morgenthaler, "Three-dimensional digital topology:the genus", Technical Report, No.TR-980, Computer Science Center, University of Maryland, 1980.
- [14] A.Nakamura and K.Aizawa, "On the recognition of properties of three-dimensional pictures", *IEEE Transactions on Pattern Analysis and Machine Intelligence, PAMI-7*, pp.708-713, 1985.
- [15] C.M. Park and A.Rosenfeld, "Connectivity and genus in three dimensions", Technical Report, No.TR-156, Computer Science Center, University of Maryland, 1971.
- [16] A.Rosenfeld and D.L.Milgram, "Parallel/sequential array acceptor", *Information Processing Letters*, 2, pp.43-46,1976.
- [17] A.Rosenfeld, "Three-dimensional digital topology", *Information and Control*, 50, pp.119-127, 1981.
- [18] M.Sakamoto, K.Inoue, and I.Takanami, "A two-way nondeterministic one-counter languages not accepted by any nondeterministic rebound automata", *IEICE Transactions*, E73-D(6), pp.879-881, 1990.
- [19] M.Sakamoto, K.Inoue, and I.Takanami, "Three-dimensionally fully space constructible functions", *IEICE Transactions on Information and Systems*, E77-D(6), pp.723-725, 1994.
- [20] M.Sakamoto and K.Inoue, "Three-dimensional alternating Turing machines with only universal states", *Information Sciences — Information and Computer Sciences*, 95, pp.155-190, 1996.
- [21] M.Sakamoto, H.Okabe, S.Nogami, S.Taniguchi, T.Makino, Y.Nakama, M.Saito, M.Kono, and K.Inoue, "A note on four-dimensional finite automata", *WSEAS Transactions on Computers*, Issue 5, Vol.3, pp.1651-1656, 2004.
- [22] M.Sakamoto, N.Tomozoe, H.Furutani, M.Kono, T.Ito, Y.Uchida, and H.Okabe, "A survey of automata on three-dimensional input tapes", *WSEAS Transactions on Computers*, Issue 10, Vol.7, pp.1638-1647, 2008.
- [23] S.Seki, "Real-time recognition of two-dimensional tapes by cellular automata", *Information Sciences*, 19, pp.179-198, 1979.
- [24] A.Szepietowski, "On three-way two-dimensional multicounter automata", *Information Sciences*, 55, pp.35-47, 1991.
- [25] H. Taniguchi, K. Inoue, I. Takanami, and S. Seki, " $(k,l)$ -Neighborhood template  $\mathcal{A}$ -type bounded cellular acceptors", *The Transactions of the IECE, Japan*, J64-D(3), pp.244-251, 1981.
- [26] H.Taniguchi, K.Fujii, K.Inoue, and I.Takanami, " $k$ -Neighborhood template  $\mathcal{A}$ -type two-dimensional bounded cellular acceptors (Part II)", Technical Report, No.AL82-19, IECE, Japan, 1982.
- [27] H.Taniguchi, K.Inoue, and I.Takanami, "Hierarchical properties of the  $k$ -neighborhood template  $\mathcal{A}$ -type 2-dimensional bounded cellular acceptor", *The Transactions of the IECE, Japan*, J69-D(7), pp.1025-1034, 1986.
- [28] G.Tourlakis and J.Mylopoulos, "Some results on computational topology", *Journal of the Association for Computing Machinery*, 20, pp.439-455, 1973.
- [29] Y.Uchida, T.Ito, M.Sakamoto, T.Ide, K.Uchida, R.Katamune, H.Furutani, M.Kono, S.Ikeda, and T.Yoshinaga, "Bottom-up pyramid cellular acceptors with four-dimensional layers", *International Journal of Artificial Life and Robotics*, Springer, 16(4), pp.529-532, 2012.
- [30] H.Umeo, K.Morita, and K.Sugata, "Pattern recognition by automata on a two-dimensional tapes (in Japanese)", *The Transactions of the IECE*, J59-P(11), pp.817-824, 1976.