

Performance Analysis of Bluetooth Low Energy Mesh Routing Algorithm in Case of Disaster Prediction

Asmir Gogic, Aljo Mujcic, Sandra Ibric, Nermin Suljanovic

Abstract—Ubiquity of natural disasters during last few decades have risen serious questions towards the prediction of such events and human safety. Every disaster regardless its proportion has a precursor which is manifested as a disruption of some environmental parameter such as temperature, humidity, pressure, vibrations and etc. In order to anticipate and monitor those changes, in this paper we propose an overall system for disaster prediction and monitoring, based on wireless sensor network (WSN). Furthermore, we introduce a modified and simplified WSN routing protocol built on the top of the trickle routing algorithm. Routing algorithm was deployed using the bluetooth low energy protocol in order to achieve low power consumption. Performance of the WSN network was analyzed using a real life system implementation. Estimates of the WSN parameters such as battery life time, network size and packet delay are determined. Based on the performance of the WSN network, proposed system can be utilized for disaster monitoring and prediction due to its low power profile and mesh routing feature.

Keywords—Bluetooth low energy, disaster prediction, mesh routing protocols, wireless sensor networks.

I. INTRODUCTION

NATURAL disasters generally occur as a result of long-term silent background processes in Earth's atmosphere and core, or due to human influence [1], [2]. Furthermore, every disaster has a precursor which is manifested as a disruption in some of the environmental parameters such as temperature, humidity, pressure, vibrations and etc. In order to anticipate and monitor such disturbances of environmental parameters, a low powered and distributed system such as wireless sensor network (WSN) should be considered [3], [4].

Nowadays, there are many wireless communication protocols which can be utilized for the deployment of the WSN such as ZigBee, Z-Wave, 6LoWPAN, WiFi, ANT, and Bluetooth Low Energy (BLE) [5]- [7]. Generally, WSN communication protocols can be classified by the utilized frequency spectrum, modulation techniques, bit rate and signal coverage. These networks use shared communication medium which by itself has its own cons and pros [5]. In opposite to advantages such as fast installation and economical reasons, main drawback of the shared communication medium, is limited transmission power, multipath signal propagation and

dispersion, fading, impulsive noise, lack of efficient medium access mechanisms [5], [8]. As such shared medium is in the focus of today's research.

WSNs are widely used as a backbone of environment monitoring systems such as air pollution monitoring [9], meteorological parameters monitoring [10], aquatic monitoring in order to determine coralline barrier health status [11], weather forecasting [12], seismological activity [13] and agriculture monitoring [14]. Authors in [15] have utilized ZigBee protocol for deployment of WSN in order to measure gas emissions and waste water quality with aim to control environmental impact of production processes in Spain instant coffee factory. An example of Bluetooth classic based WSN deployment has been demonstrated in [16], where authors tried to monitor noise level at a construction site. Additionally, authors proved the benefits of the classic Bluetooth WSN network in comparison with ZigBee network. All WSN networks struggles with the limited energy storage and authors in [17] analyzed benefits of using BLE self-powered WSN nodes for the purpose of environment monitoring. Due its unique features, such as radio frequency (RF) spectrum performance, widespread use within variety of electronic devices and ultra low power consumption, BLE makes an ideal candidate for the implementation of the WSN network [8]. Low power consumption feature directly influences signal coverage of the BLE transceiver down to 30 meters (in ideal case of optical visibility and without signal extenders). In order to achieve wider signal coverage, utilization of the mesh routing protocol is necessary [18], [19]. Absence of the standardized and efficient mesh routing protocol limits BLE utilization in spatially distributed sensors networks [8]. So far, several solutions have been presented to overcome a problem of mesh routing in BLE WSNs [20], [21]. Bluetooth Special Interest Group has formed Bluetooth Smart Mesh Working Group to work on standardization of mesh networking capabilities for BLE technology and profiles are expected to be officially adopted in 2016 [22]. CSRmesh is one example of the mesh flooding protocol running over BLE that enables BLE devices for mesh networking, so that they become suitable for Internet of Things (IoT) applications [20]. A similar approach based on the flooding based routing is proposed in [21].

In this paper, we have analyzed a performance of the Bluetooth Low Energy mesh wireless sensor network routing algorithm in a case of disaster prediction and monitoring application. In order to reduce power consumption imposed

A. Gogic is with the Department of Telecommunication at the Faculty of electrical engineering, University of Tuzla, Bosnia and Herzegovina (e-mail: asmir.gogic@untz.ba).

A. Mujcic, S. Ibric and N. Suljanovic are with Department of Telecommunication at the Faculty of Electrical Engineering, University of Tuzla, Bosnia and Herzegovina.

by the routing algorithm, a simple sleep/awake technique was introduced. The performance of the routing algorithm was analyzed on a real life WSN implementation on the basis of the network size, power consumption and packet delay. As a result, estimate of the node energy consumption is derived as a function of the WSN network size. Results showed that the BLE WSN network is able to operate for a period of one year due to the low power consumption and effective mesh routing technique.

II. PRINCIPALS BEHIND THE WIRELESS SENSOR NETWORK

Wireless sensor network represents a group of application specific, wirelessly enabled devices called nodes. WSN nodes monitor one or a few environmental parameters of some physical phenomena [23]. On the other hand, WSN is a self-organized wireless network of nodes whose common goal is packet transmission toward the gateway node. Gateway node is commonly a node whose main task is to transmit the data into a bigger network or Internet using same or different wireless/wired communication interface. Commonly WSN nodes are spatially distributed in harsh environments with small or none accessibility and possibility for maintenance. A distinct feature of the WSN network when compared to the traditional wired network is that node roles varies in accordance with a medium state or activity of the neighboring nodes [24], [25]. Furthermore, nodes are battery powered devices which implies that hardware has to be energy efficient and reliable to provide long-lasting operation [26].

Numerous communication standards such as Zigbee, Bluetooth, BLE, ANT, LoRaWAN, Z-Wave, can be utilized for deployment of the WSN [5]. Selection of the data carrying protocol is application specific. Each WSN network is characterized by its efficiency, node deployment, scalability, interoperability, coverage and quality of service (QoS) [24]. In order to increase network efficiency, utilization of the energy aware medium access algorithm should be considered. Generally, this is achieved through the employment of *sleep* mode [25], [27]. During the sleep mode, node transceiver is shutdown while the state of the sensing part is application specific. Due to spatial and distributed deployment, WSN network topology may take different forms: Tree, star or mesh [16], [23]. In most cases, nodes are randomly deployed, and as a consequence the number of directly reachable nodes is reduced. Information propagation within the mesh network is achieved through the employment of the routing algorithms. The routing and medium access algorithms often do not scale with the network size [23].

III. BLUETOOTH LOW ENERGY

Bluetooth Low Energy (BLE) also know as Bluetooth Smart, is a technology for Wireless Personal Networks (WPAN) developed by Bluetooth Special Interest Group [28]. The aim is to provide lower power consumptions and costs compared to Bluetooth classic. BLE communication protocol stack incorporates two parts: Controller and Host. Physical and Link layer functionalities reside in controller

and upper layers functionalities are implemented in host part. Some of the controller features are inherited from Bluetooth classic Controller. However, BLE and Bluetooth classic are not compatible. Communication between these two parts is achieved through the Host Controller Interface (HCI) [8].

From frequency spectrum perspective, BLE operates in 2.4 GHz ISM (Industrial, Scientific and Medical) band and employs 40 physical channels with 2 MHz spacings. Two types of channels are utilized and these includes three advertising channels and 37 data channels. The fact that BLE uses fewer advertising channels in comparison to Bluetooth classic, leads to lower power consumption. The main purpose of advertising channels is announcement of supported service and connection parameters [28]. Interference and fading in BLE is mitigated through the employment of Frequency Hopping Spread Spectrum (FHSS) technique.

Within the controller BLE implements section called Generic Access Profile (GAP) responsible for BLE device interaction [28]. BLE devices communicate with each other using broadcasting or connections. Using broadcasting data is transmitted to all neighboring device and devices which are listening for the data are called observers. Broadcasting is the only way for devices to send data to multiple peers. However, it is inappropriate for the transmission of data requiring security and privacy. Bidirectional communication is achieved through the employment of connections. This type of communication defines following device roles: Central or master and peripheral or slave. In general sense, connection represents periodical data exchange which follows timing managed by central device. Although, master device controls connection establishment, both devices involved in the communication can send their data without any restrictions.

IV. ROUTING ALGORITHMS IN THE WIRELESS SENSOR NETWORKS

All routing protocols can be classified according to the network topology, route establishment process or protocol operation [24], [25]. Routing algorithm employs a metric, which is a physical parameter, for the selection of the next node towards the destination. The most common metrics used in the routing algorithms are: number of hops toward the destination node, energy efficiency and network segmentation time [5]. Since the WSN nodes have limited computational resources, utilization of traditional wireless routing algorithms is not applicable. Hence, a simplified and energy aware routing algorithms are used.

Flooding is the oldest routing algorithm commonly used within the WSN due to its simplicity [29], [30]. The flooding is fundamental strategy for information propagation towards the destination node where each node in WSN broadcasts only the messages which are seen for the first time. In the flooding process, if there is a path between the start and end node, packet delivery is guaranteed. Main downside of the flooding algorithm is that it generates a huge amount of the traffic within the network. Additionally, a flooding-based algorithms suffer from issues such as implosion, overlap and resource blindness [6]. Due to its simplicity, flooding

algorithm is used as a starting point in development of new routing protocols for WSN. Reduction of the traffic within the network can be used in a way that packets are forwarded with a certain probability. This approach is utilized in the gossiping algorithm [24], [25]. In the gossiping algorithm, a number of neighboring nodes defines the re-broadcast probability. A higher number of the neighboring nodes leads to a lower probability for data rebroadcast. Due to the reduced number of broadcasted packets, gossiping algorithm have higher packet delay in contrast to pure flooding algorithm. The flooding and gossiping algorithms represents two boundary cases regarding the targeted QoS parameters.

Another fundamental routing approach is convergecast, in which data is collected at particular nodes and aggregated toward the network coordinator node. When the source node has to send the data, it broadcasts the packet to its neighboring nodes. The nodes which have received the data, initiate the converge transmission toward the network coordinator. Utilization of the Ad-hoc On-demand Distance Vector (AODV) routing algorithm within the ultra low power networks is not feasible due to the computational requirements and the energy efficiency. These algorithm tends to reduce the WSN energy performance with a network growth.

An example of gossiping-like routing algorithm is trickle algorithm which reduces the amount of control traffic [31]. Once the consistency within the WSN network is established, trickle algorithm tends to use a small overhead for network maintenance. Trickle algorithm employs three variables: Current interval size I , a time within current interval t when the nodes switches roles from observer to broadcaster, and a consistency counter c [31]. Current interval size defines period of time where in its first part node observes the medium for traffic and in second part re-transmits the received packets. During the first part of interval I each time when node detects the transmission that is consistent counter c is incremented. Initially, algorithm sets I within the range $[I_{min}, I_{max}]$ (the minimum interval size I_{min} , maximum interval size I_{max}), and counter c is set to 0. If at the timer interval t counter value c is lower than redundancy constant, node can transmit data. When one interval ends, new interval size is double value of previous interval size. In case that $2I > I_{max}$, new interval size is set to I_{max} . Inconsistent transmission resets the trickle timer. If I is greater than I_{min} when inconsistent event happens, algorithm sets I to I_{min} and starts new interval with this parameter. Since the trickle algorithm only defines time intervals when messages should be sent but not how, it has been used as starting point for development of numerous routing protocols [32]–[36].

V. ENVIRONMENTAL PARAMETER MONITORING - SYSTEM STRUCTURE

The proposed system for environmental parameter monitoring consists of two segments: WSN networks and Web management platform (Fig. 1). WSN networks contain two types of nodes: one gateway node and many sensor nodes. Both gateway and sensor nodes incorporate nRF51822 SoC (*System on Chip*) based on ARM Cortex

M0 microcontroller and BLE 4.0 compliant transceiver [37], wakeup mechanism built around real time clock (PCF8563) [38] and battery monitoring segment (Fig. 2). Furthermore, sensor nodes include sensing elements such as accelerometer ADXL362 [39] for measuring motion/vibrations, temperature and humidity sensor SHT21 [40]. Measurements of vibration and motion are used for the detection of seismic events [41].

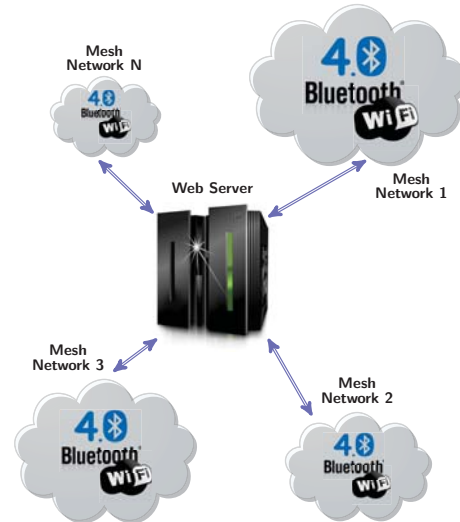

Fig. 1 Overall system structure of proposed system

Gateway nodes differ from sensor nodes in a way that they do not include sensing part but rather IEEE 802.11 b/g enabled transceiver CC3100 for establishing the TCP/IP connection with the remote server [42]. Another difference is that the battery capacity for the gateway is significantly higher since the WLAN transceiver drains large currents during the transmissions in comparison to BLE transceiver.

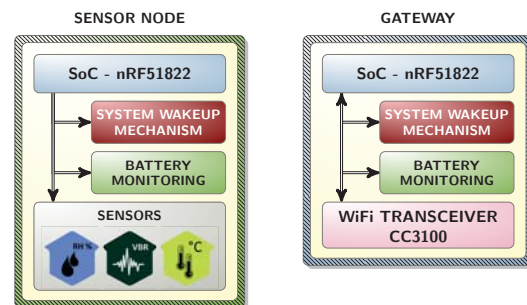

Fig. 2 Gateway and sensor node model

Information dissemination within the WSN is achieved through utilization of the trickle routing algorithm [31]. By its nature, trickle algorithm defines time intervals when messages should be sent within the network, but not the way how to accomplish it. Trickle algorithm mandates that all nodes in the network must observe/broadcast medium state during the life time of network. This feature is not acceptable for the WSN since it significantly reduces WSN life time in regards to battery consumption. To avoid this problem, sensor nodes are periodically put into the power off mode every t_{off} (ms) (Fig. 3). This modification reduces the power consumption

but introduces the potential problem where two sensor nodes could lose synchronization with regards to their current mode. In other words, one WSN sensor node could be in power-off mode while the neighboring node could be in active mode.

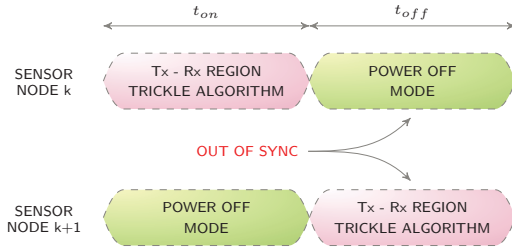

Fig. 3 Medium state for out of synchronization problem

To ensure that the messages are propagated through the network without a loss (due to the algorithm modification), when nodes lose their synchronization, we have increased the observing/broadcasting interval (in which trickle operates) for the value t_{off} . In such way, even if the sensor nodes are not synchronized, messages will be propagated through the network since the active and power off mode of neighboring nodes will overlap. The drawback of this modification is that nodes will stay longer in active mode when there is a message to be sent, thus increasing the power consumption. Since data from sensor nodes is transmitted towards the gateway every few seconds or minutes, this extension of the active period is acceptable. Another disadvantage is that total packet delay in worst case scenario could reach up to $(t_{on} + t_{off}) \cdot N_{hops}$, where N_{hops} is number of hops for farthest node in the WSN.

Sensor nodes perform periodical readings of all installed sensors every t_{read} seconds. If the measured parameters are within the given thresholds, data is internally stored and sent to gateway every t_{sen-tx} seconds (where $t_{sen-tx} \geq t_{read}$). Since changes in temperature and humidity vary slowly over time, these information can be collected less frequently. Detection of the motion/vibration is based on accelerometer readings using polling method (same as for the temperature and humidity). Additionally, a threshold based motion algorithm is used during the sleep of accelerometer in order to catch any potential motion/vibration of interest. Wakeup mechanism uses external RTC who generates trigger event for transition from a power-off mode to active mode every $t_{wake} = t_{on} + t_{off}$ seconds. In a case that there are data from other nodes pending to be transmitted, t_{on} period is extended to the value t_{off} so that the active and power-off modes of neighboring nodes would overlap.

Web management platform structure is shown in Fig. 4 and includes TCP server listening on a specific port (in our case 5000) for incoming connections from WSN. Furthermore, WSN communicates with TCP server by using WiFi connection. When TCP server receives data, it parses the message and stores it to dedicated database. Database contains collected values of all monitored parameters for each node within the WSN. Stored data from database is presented in real-time form of graphs (Fig. 5). In order to incorporate a predictions of disaster events based on measurements, Web

management platform includes database monitoring agent with a purpose to detect when certain parameters that are above or below given threshold. Database monitoring agent utilizes a predefined profiles for environmental parameters prediction. As a result, notifications are generated using different communication protocols such as email, SMS or cellular calls based on the client subscriptions.

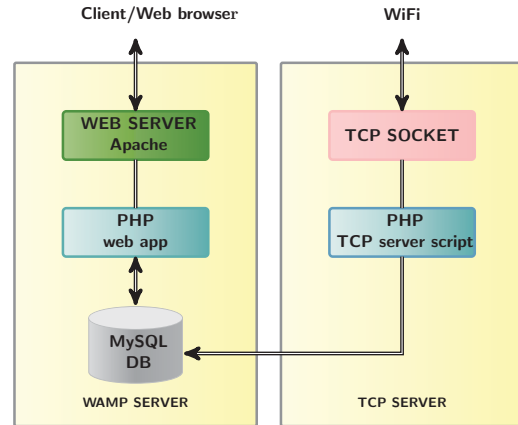

Fig. 4 Block scheme of web management platform

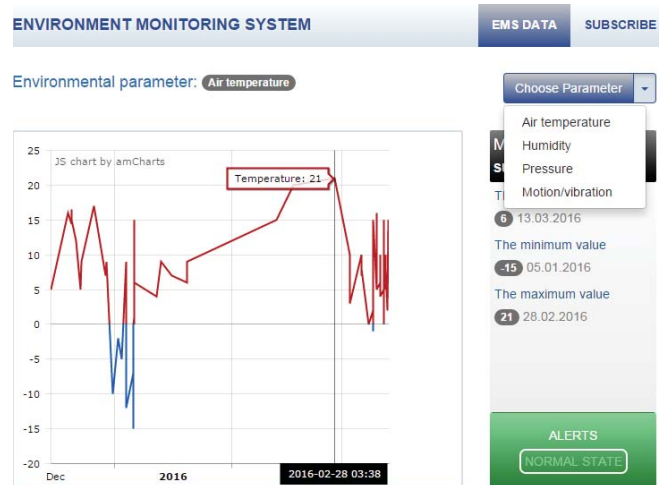

Fig. 5 Web management system - Client interface

VI. MEASUREMENT SETUP AND RESULTS

Before the WSN is deployed (on the top of the buildings so that vibrations would be amplified), maximal distance between the two neighboring sensor nodes had to be determined. Signal level between two neighboring nodes where measured in order to obtain such estimate. Measurements are completed when one node is actively transmitting at 0 dBm and another listening (observing) with maximum sensitivity of -96 dBm (Fig. 6). Both nodes where equipped with nRF51822 QFAC-A1 BLE SoC mounted on PCB (Printed Circuit Board module equipped with minimal circuitry and PCB folded F antenna (Fig. 7).

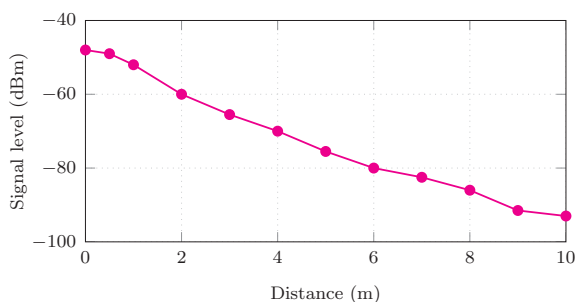

Fig. 6 nRF51822 BLE signal level between two neighboring WSN nodes



Fig. 7 Minimum working development BLE module nRF51822 SoC

Performance analysis of the trickle algorithm was completed on a simple version of the disaster monitoring and management system comprised of one WSN and one Web management platform. WSN was made of six sensor nodes and one gateway (Fig. 8). Measurements of motion/vibration, temperature and humidity were recorded on each of the sensor nodes. For the sensor nodes 3.7 V and 6000 mAh LiPo (*Lithium Polymer*) batteries were utilized while for the gateway they were 3.7 V and 8000 mAh LiPo. WSN nodes are built in modular manner from pre-built modules so they can be easily reconfigured to perform functions of sensor or gateway (Fig. 9).

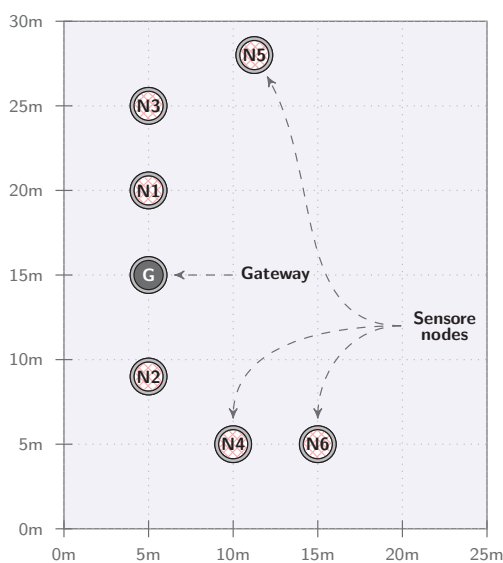

Fig. 8 WSN Network topology

Sensor nodes were configured with sleep time equals to $t_{off} = 9.5 s$ and active time $t_{on} = 0.5 s$. In active mode, 380 ms of 500 ms are required for the BLE communication stack to be initialized during which BLE SoC drains 4 mA. The remaining 120 ms are used for the trickle algorithm. Wakeup period is set to 10 seconds and the sensor sampling time is equal to $6 \cdot (t_{off} + t_{on})$, during which sensor collects 94 bits which can fit in one BLE packet whose maximum size is 20 bytes. Sensor data is comprised of 12 bits for temperature, 12 bits for humidity, 32 bits for RTC time and 3 sets of 12 bits for accelerometer axis readings. In sleep time sensor node current consumption is limited to $1.2\mu A$ which is a result of on board power regulator (performs voltage conversion from 3.7 V to 3 V), BLE SoC, RTC and accelerometer sleep currents (Table I).

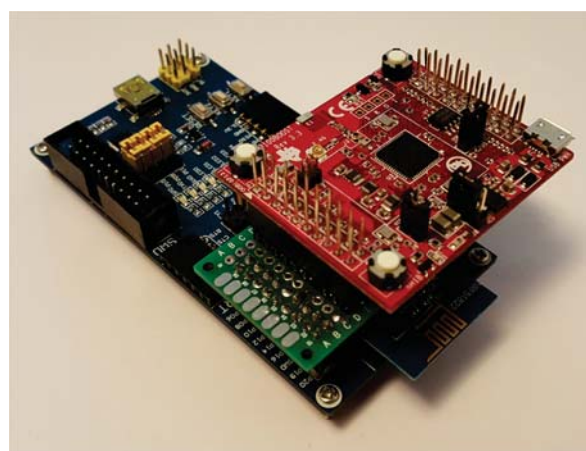

Fig. 9 WSN modular node - gateway

Total current in active state is comprised from two part: Current during sensor data collection and processing, and BLE observe/broadcast current. When BLE is performing a roll of observer total current of RF part is 9.7 mA while for the broadcast role its 8 mA, for an average period of 60 ms (Table I). These currents were measured on nRF51822 SoC with DCDC converter enabled. Sensor capturing and processing current equals to $301.8\mu A$ for a period of 2.5 ms.

WSN efficiency is increased in a way that sensor nodes perform transmission of locally collected data every 60 seconds. In other words, after each sixth t_{wake} periods locally collected sensor data is transmitted towards the gateway. In subsequent t_{wake} periods, data from neighboring nodes are received and forwarded. The main reason for using shorter t_{off} and t_{on} periods and separation of the data transmissions from local and neighboring nodes, is to equalize the traffic frequency during all wakeup periods. Based on the measured currents during t_{off} and t_{on} periods, total battery consumption for sensor node during one day is $12.6074 mAh$. Since the battery capacity for the sensor node is $6000 mAh$ (actual value is $7400 mAh$ due to the voltage conversion from 3.7 V to 3 V), expected sensor node life time is 589 days. On the other side, gateway is designed in the similar way as sensor node with the slight modification which includes transmission of collected data using WiFi every hour. Furthermore, it is expected that

gateway establishes WiFi connection with local AP within the 15 seconds establishes and sends the accumulated data. Gateway's life time is limited to 511 days and total WSN life time is limited by gateway to 1.4 years. In case when the t_{wake} period is reduced to 1 s in order to achieve real time monitoring, total network time would be reduced down to 2 months.

TABLE I
 CURRENT CONSUMPTION AND TIME SPENT IN DIFFERENT MODES FOR EACH OF THE COMPONENTS ON THE WSN NODE

Device	Active/sleep current [μA]	Active time [s] during one day
Temperature sensor SHT 21	300/0	21.6
Real time clock PCF 8536	0.25/0.25	86400
WiFi transceiver CC3100	$2.23 \cdot 10^6/4$	120
Accelerometer ADXL 362	1.8/0.270	21.6
BLE SoC Tx nRF51822	$8.0 \cdot 10^3/0.5$	518.4
BLE SoC Rx nRF51822	$9.7 \cdot 10^3/0.5$	518.4

Gateways WiFi connection establishment periods will vary depending on the link state as well as the data transmission period. Consequently, more than 15 seconds is required for WiFi to perform those actions in case when network size reaches critical size. An average WiFi TCP connection setup time takes 12 seconds and TCP packets are limited to 1024 bytes. This leaves 3 seconds for sending $N \cdot 720 B$ of data (where N is the number of nodes within the network). Due to the limited flash resources of gateway's BLE SoC, 30 kB of flash are reserved for the intermediate storage of sensor data. This is enough memory space to support up to 40 nodes within the WSN. Larger networks can be supported with the utilization of external flash or FRAM (Ferroelectric RAM) memory.

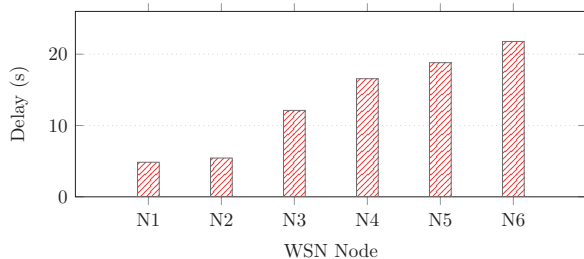

Fig. 10 Average delay for each node within the WSN

Measurements of the packet delay are performed on the test network in order to analyze impact of routing algorithm modifications (Fig. 8). Average packet delay is increased from 5 to 10 seconds per WSN node due to the desynchronization problem and signal level between the neighboring WSN nodes.

VII. CONCLUSION

In this paper, performance analysis of WSN mesh routing algorithm in a case of disaster management system, have been presented. The proposed system included WSN network and Web management platform. Low power profile of WSN was achieved through the utilization of the modified trickle routing algorithm. Modifications included addition of power-off and active mode with periodic wakeup's using external mechanism. Additionally, active mode is extended with aim to solve the desynchronization problem of neighboring nodes. Measurements of the signal level, current consumption and packet delay was completed on WSN network of seven nodes.

The results showed that the packet delay is significantly larger in contrast to the wired application but due to the nature of the application this is acceptable. The main downside of the proposed system is that sensor data is transmitted to remote server using WiFi, which limits the WSN accessibility. Possible workaround for this problem is to use 3G cellular modem or to store the data on the gateway into some external media such as flash memory. Due to limited energy WSN network life time was limited to 1.4 years. Extension of the network life time can be achieved through the utilization of the solar panel whose total generated energy during the day should cover consumed energy during the day and night. Web management platform was developed with aim to monitor environmental parameters. Furthermore, using the various criterion's on data, database monitoring agent can make predictions of potential anomalies and alarms can be generated.

ACKNOWLEDGMENT

The research was funded by Ministry of science, culture and education, Federation of Bosnia and Herzegovina, program *Support for research in Federation in 2014*, grant number 01/2-2995/15 from 26.05.2015, project name *"Wireless communication system for environmental parameter monitoring with aim of natural disaster prediction"*.

REFERENCES

- [1] D. Chen, Z. Liu, L. Wang, M. Dou, J. Chen and H. Li, "Natural disaster monitoring with wireless sensor networks: A case study of data-intensive applications upon low-cost scalable systems," *Mobile Networks and Applications*, vol. 18, no. 5, pp. 651–663, Aug. 2013.
- [2] M. Lindell and C. Prater, "Assessing community impacts of natural disasters," *Natural Hazards Review*, vol. 4, no. 4, pp. 176–185, Nov. 2003.
- [3] B. H. Calhoun, D. C. Daly, N. Verma and D. F. Finchelstein, D. D. Wentzloff, A. Wang, S. H. Cho and A. P. Chandrakasan, "Design considerations for ultra-low energy wireless microsensor nodes," *IEEE Trans. Comput.*, vol. 54, no. 6, pp. 727–749, Jun. 2005.
- [4] G. J. Pottie and W. J. Kaiser, "Wireless integrated network sensors," *Magazine Communications of the ACM*, vol. 43, no. 5, pp. 51–58, May 2000.
- [5] D. Walthenegus and C. Poellabauer, *Fundamentals of Wireless Sensor Networks: Theory & practice*. Southern Gate, Chichester, West Sussex, PO19 8SQ, UK: John Wiley & Sons Ltd., 2010.
- [6] W. B. Heinzelman, A. P. Chandrakasan, and H. Balakrishnan, "An application specific protocol architecture for wireless microsensor networks," *IEEE Trans. Wireless Commun.*, vol. 1, no. 4, pp. 660–670, Oct. 2002.
- [7] M. Othman and K. Shazali, "Wireless sensor network applications: A study in environment monitoring system," *Procedia Engineering*, vol. 41.

- [8] C. Gomez, J. Oller and J. Paradells, "Overview and evaluation of bluetooth low energy: An emerging low-power wireless technology," *Sensors*, vol. 12, no. 9, pp. 11 734–11 753, Aug. 2012.
- [9] A. Kadri, E. Yaacoub, M. Mushtaha and A. Abu-Dayya, "Wireless sensor network for real-time air pollution monitoring," in *1st International Conference on Communications, Signal Processing, and their Applications (ICCSA)*, Feb. 2013, pp. 1 – 5.
- [10] N. Suljanovic, A. Gogic, A. Mujcic, I.H. Cavdra and M. Zajc, "The role of mac routing in wireless sensor networks," in *Proc. Signal Processing and Communications Applications Conference, Trabzon, Turkey*, Apr. 2014, pp. 2323–2326.
- [11] C. Alippi, R. Camplani, C. Galperti and M. Roveri, "A robust, adaptive, solar-powered wsn framework for aquatic environmental monitoring," *IEEE Sensors Journal*, vol. 11, no. 1, pp. 45–55, Jan. 2011.
- [12] G. Barrenetxea, F. Ingelrest, G. Schaefer and M. Vetterli, "Wireless sensor networks for environmental monitoring: The sensorscope experience," in *Proc. IEEE International Zurich Seminar on Communications*, Zurich, Switzerland, Mar. 2008, pp. 98–101.
- [13] G. Werner-Allen, J. Johnson, M. Ruiz, J. Lees and M. Welsh, "Monitoring volcanic eruptions with a wireless sensor network," in *Proc. 2nd European Workshop Wireless Sensor Networks*, Istanbul, Turkey, Jan. 2005, pp. 108–120.
- [14] S. Verma, N. Chug and D. V. Gadre, "Wireless sensor network for crop field monitoring," in *Recent Trends in Information, Telecommunication and Computing (ITC), 2010 International Conference on*, Kochi, Kerala, Mar. 2010, pp. 207–211.
- [15] J. Valverde, V. Rosello, G. Mujica, J. Portilla, A. Uriarte, and T. Riesgo, "Wireless sensor network for environmental monitoring: Application in a coffee factory," *International Journal of Distributed Sensor Networks*, vol. 2012.
- [16] J. Hughes, J. Yan and K. Soga, "Development of wireless sensor network using bluetooth low energy (BLE) for construction noise monitoring," *International Journal on Smart Sensing and Intelligent Systems*, vol. 8, no. 2, pp. 1379–1405, Jun. 2015.
- [17] C. M. Nguyen, J. Mays, D. Plesa, S. Rao, M. Nguyen and J. C. Chiao, "Wireless sensor nodes for environmental monitoring in Internet of Things," in *Microwave Symposium (IMS), 2015 IEEE MTT-S International*, Phoenix, AZ, May 2015, pp. 1–4.
- [18] Z. Guo, I. G. Harris, L. Tsaur and Xianbo Chen, "An on-demand scatternet formation and multi-hop routing protocol for ble-based wireless sensor networks," in *Proc. Wireless Communications and Networking Conference*, New Orleans, LA, Mar. 2015, pp. 1590–1595.
- [19] C. Schurgers and M. B. Srivastava, "Energy efficient routing in wireless sensor networks," in *Military Communications Conference*, Oct. 2001, pp. 357–361.
- [20] CSR, "Csrsmesh," Tech. Rep., Mar. 2015.
- [21] H. S. Kim, J. Lee and J.W. Jang, "Blemesh: A wireless mesh network protocol for bluetooth low energy devices," in *Proc. 3rd International Conference on Future Internet of Things and Cloud (FiCloud)*, Rome, Italy, Aug. 2015, pp. 558–563.
- [22] Bluetooth Special Interest Group, "Bluetooth technology adding mesh networking to spur new wave of innovation," Press Release, Tech. Rep., Feb. 2015.
- [23] J. Chen, S. Li, and Y. Sun, "Novel deployment schemes for mobile sensor networks," *Sensors*, vol. 7, no. 11, pp. 2907–2919, Nov. 2007.
- [24] M. Matin and M. Islam, "Overivew of wireless sensor network," in *Wireless Sensor Networks - Technology and Protocols*, D. M. Matin, Ed. InTech, 2012.
- [25] J. N. Al-Karaki and A. E. Kamal, "Routing techniques in wireless sensor networks: A survey," *IEEE Wireless Commun. Mag.*, vol. 11, no. 6, pp. 6–28, Dec. 2004.
- [26] Z. Abbas and W. Yoon, "A survey on energy conserving mechanisms for the internet of things: Wireless networking aspects," *Sensors 2015*, vol. 15, no. 10, pp. 24 818–24 847, Sep. 2015.
- [27] SS. Chalasani and J.M. Conrad, "A survey of energy harvesting sources for embedded systems," in *Southeastcon, 2008. IEEE*, Apr. 2008, pp. 442–447.
- [28] Bluetooth Special Interest Group, "Bluetooth specification version 4.0," Tech. Rep., Jun. 2010.
- [29] G. Lu, B. Krishnamachari, and C. S. Raghavendra, "An adaptive energy-efficient and low-latency MAC for data gathering in wireless sensor networks," in *Proc. International Parallel and Distributed Processing Symposium*, Santa Fe, New Mexico, USA, Apr. 2004, pp. 224–231.
- [30] V. Annamalai, S. K. S. Gupta, and L. Schwiebert, "On tree-based convergcasting in wireless sensor networks," in *Proc. IEEE Wireless Communications and Networking Conference*, Mar. 2003, pp. 1942–1947.
- [31] P. Levis, T. Clausen, J. Hui, O. Gnawali and J. Ko, "The Trickle Algorithm," Tech. Rep. RFC 6206, 2011.
- [32] M. Stolikj, T.M.M. Meyfroyt, P.J.L. Cuijpers and J.J. Lukkien, "Improving the performance of trickle-based data dissemination in low-power networks," *CoRR*, vol. abs/1509.08654, Oct. 2015. [Online]. Available: <http://arxiv.org/abs/1509.08654>
- [33] P. Levis, N. Patel , D. Culler and S. Shenker, "Trickle: A self-regulating algorithm for code propagation and maintenance in wireless sensor networks," in *Proc. of the First Symposium on Networked Systems Design and Implementation*, , Mar. 2004, pp. 15–28.
- [34] O. Gnawali, R. Fonseca, K. Jamieson, D. Moss and P. Levis, "Collection Tree Protocol," in *Proc. of the 7th ACM conference on embedded networked sensor systems*, Nov. 2009, pp. 1–14.
- [35] J. Hui and R. Kelsey, "Multicast Protocol for Low power and Lossy Networks (MPL)," Tech. Rep., 2014.
- [36] T. Winter, P. Thubert, A. Brandt, J. Hui, R. Kelsey, P. Levis, K. Pister, R. Struik, J. Vasseur and R. Alexander, "RPL: IPv6 Routing Protocol for Low-Power and Lossy Networks," Tech. Rep. RFC 6550, 2012.
- [37] Nordic Semiconductor, "nRF51 Series Reference manual v3.1," Tech. Rep., 2014.
- [38] NXP Semiconductors, "PCF8563 manual," Tech. Rep., 2015.
- [39] Analog Devices, "ADXL362 manual," Tech. Rep., 2015.
- [40] Sensirion, "SHT21 manual," Tech. Rep., 2011.
- [41] A. Zollo, O. Amoroso, M. Lancieri, Y.M. Wu and H. Kanamori, "A threshold-based earthquake early warning using dense accelerometer networks," *Geophysical Journal International*, vol. 183, no. 2, pp. 963–974, Aug. 2010.
- [42] Texas Instruments, "CC3100 SimpleLink Wi-Fi Network Processor, Internet-of-Things Solution for MCU Applications," Tech. Rep., 2015.