

The Operating Behaviour of Unbalanced Unpaced Merging Assembly Lines

S. Shaaban, T. McNamara, S. Hudson

Abstract—This paper reports on the performance of deliberately unbalanced, reliable, non-automated and assembly lines that merge, whose workstations differ in terms of their mean operation times. Simulations are carried out on 5- and 8-station lines with 1, 2 and 4 buffer capacity units, % degrees of line imbalance of 2, 5 and 12, and 24 different patterns of means imbalance. Data on two performance measures, namely throughput and average buffer level were gathered, statistically analysed and compared to a merging balanced line counterpart. It was found that the best configurations are a balanced line arrangement and a monotone decreasing order for each of the parallel merging lines, with the first generally resulting in a lower throughput and the second leading to a lower average buffer level than those of a balanced line.

Keywords—Average buffer level, merging lines, simulation, throughput; unbalanced.

I. INTRODUCTION

UNPACED asynchronous parallel merge lines are high volume stochastic serial queuing systems. With no form of mechanical pacing, workers along the line are free to work at their own pace. Provisions are usually made for keeping partly finished work-in-process inventories between stations so that when work is completed at one station, the item is transferred to a storage location, called a “buffer”. Fig. 1 shows a typical merging assembly line comprised of a series of parallel workstations and buffers, and a final merge or assembly station.

In the design of an unpaced merging serial assembly line, one of the main issues to be considered if efficiency is to be enhanced is where to place operators who work at different speeds. The focus of research in this area has for the most part concentrated on how best to achieve a “balanced” line, where the operator average service time at each workstation is the same, as this type of design has been perceived as leading to the best efficiency. In real life, however, processing times have been shown by [1] to be non-identical at different workstations, even in automated lines. In unpaced lines, this effect is exacerbated since operators at each station can vary according to their physical capacity, their motivation, or due to task complexity, or just simply that the amount of work along the line cannot be distributed evenly. These differences in mean operation times (MTs) were shown by [2] to lead to blocking and starving along the line, with a resulting impact

on average buffer level (ABL) and throughput (TR). In view of this, the allocation of the operators along the line becomes an important consideration, and the issue of how to improve performance in an unbalanced parallel merging line is one that needs to be investigated.

The structure of this article is as follows. First, the relevant literature is reviewed in Section II. Next, the motivation and objectives of the study are presented in Section III. The methodology and experimental design are discussed in Section IV, with the simulation results and analysis given in Section V. The results are then summarised and discussed in Sections VI and VII.

II. LITERATURE REVIEW

One of the early findings in the study of mean time imbalance suggested that placing workstations with higher average processing times at both ends of the line could lead to improved performance in terms of throughput (TR), compared to the balanced line. This effect was termed the “bowl phenomenon” by [3]. There has been continued interest in testing this phenomenon over the years, which show varying degrees of support for this conclusion, with most recently a move towards looking at patterns of imbalance rather than focusing purely on the bowl phenomenon, as argued by [2], [4]-[9].

Of more immediate relevance to the investigation performed in this paper is work that concerns production lines (or assembly lines) that merge. Similarly, to the literature on serial production lines, it is assumed that balancing merging lines yields superior performance, as put forth by [10]. However, there is some, albeit sparse, evidence that unbalanced configurations can also perform well, or sometimes better than the balanced equivalent. Below we provide a brief overview of some of the main findings.

Reference [11] did an early simulation comparison study between a system comprised of two serial lines operating in parallel versus a production line composed of an equal number of stages in which each stage had two stations that merged. Both systems were subject to failure and had normally distributed processing times. In general, it was found that a configuration of a series of merging stations provided better performance than that of parallel serial lines.

Reference [12] developed a simulation model for the evaluation of the performance of production systems, with the stated goal being to bring them into balance. Their model was capable of analyzing merging lines subject to stochastic processing times.

S. Shaaban is with ESC La Rochelle, La Rochelle, 17024, France (phone +33 (0) 546 51 77 00; e-mail: shaabans@esc-larochelle.fr).

T. McNamara and S. Hudson are with the ESC Rennes School of Business, Rennes, 35065, France (e-mail: tom.mcnamara@esc-rennes.com, sarah.hudson@esc-rennes.com).

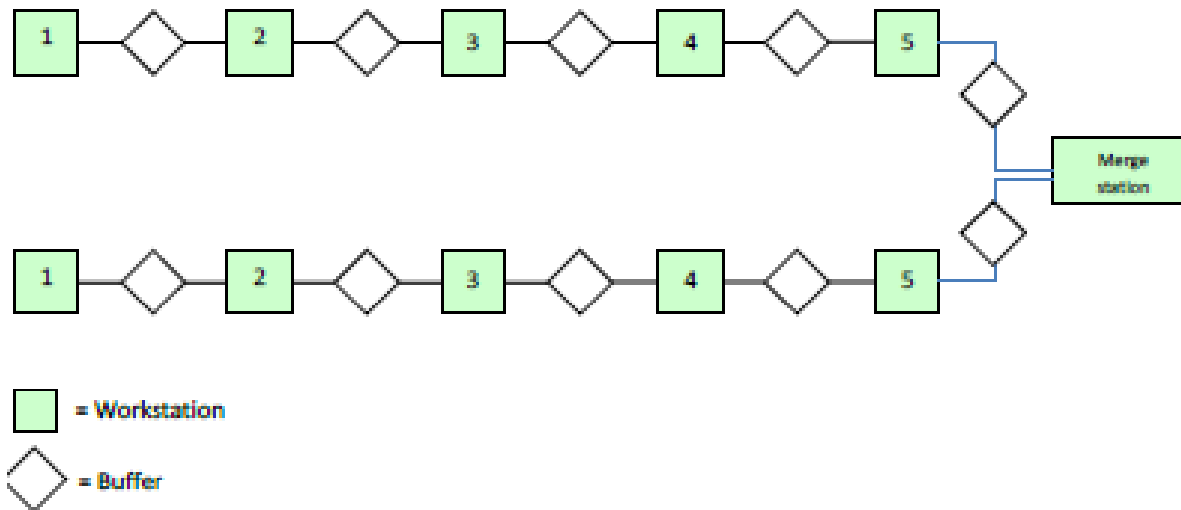

Fig. 1 An assembly line with 5 parallel stations and a merge station

Reference [13] devised a method for evaluating and predicting the performance of assembly systems comprised of an assembly stage that is fed by two or more stages (a merging line), in which the stages have unequal cycle times and are subject to failure.

Reference [14] investigated merging assembly systems and found that systems operating under “push” mode had higher levels of average output than those functioning under “pull” mode.

In a later study, [15] used mathematical analysis for a three-station merging system with two feeder and one assembly station. They found that the optimal configuration was unbalanced, and that more extreme imbalance where the feeder stations were slower than the assembly station at a work allocation ratio of approximately 1.15 to 0.7. Throughput remained steady (at 1.56% from optimal) for assembly station work allocation ranging from 0.42 to 1. Simulations of longer 2-station feeder lines showed lower improvements in TR overall. The authors also reported that TR results were better in the unbalanced than the balanced system where work was allocated equally.

Reference [16] used simulation to study the effect of variability on a three-station merging assembly system. It was found that greater improvements to TR were possible from increasing the production rate (lowering the processing times) of individual stations than from increasing the size of buffers.

Reference [17] developed an efficient approximation method for determining the output of a simple three-station assembly system having random unbalanced processing times.

Reference [18] arrived at general guidelines regarding the efficient placement of buffers in unbalanced assembly systems having random processing times.

The notion that unbalanced feeder lines in a merging line can perform equally well or better than a balanced system finds support in an article published by [19]. In their study, the authors aimed to determine where to allocate service capacity in workstations ($N = 2$ or 3), split into parallel servers in order to maximize throughput. Two of their conclusions are of

particular interest. First, they suggest that for fixed resources, the ‘symmetrical allocation’ property holds, i.e. having equal numbers of parallel servers on stations one and three, with more assigned to the middle station. When imbalance becomes too severe, a server is removed from the middle station and one added to the first and third stations to keep TR optimal. Second, they note that for any set of parameters maximizing TR, the bowl phenomenon holds. Finally, they also observe that more severe imbalance in a bowl shape is possible in these parallel servers than in a serial transfer line. In addition, from their observations on output, it is noted that in line with [15], best results are likely when the feeder stations are faster than the merge station.

Reference [20] put forth an approximation method for determining the performance of assembly/disassembly systems that contained merging stations. The lines investigated are subject to breakdown and have exponential failure, repair and processing rates.

Reference [21] studied an unreliable merging system comprised of two stations in parallel having different processing rates that feed into a common buffer, which in turn feeds an assembly station. A decomposition method for determining the production rate and expected buffer levels was developed.

Reference [22] used simulation to study the effects on TR and variability of inter-departure times in assembly systems in which the number of stations as well as their processing times and variability were all design factors. Guidelines regarding the more efficient design of production systems were furnished.

Reference [23] investigated merging assembly systems with unequal buffers and exponential processing time distributions. An analytical procedure which can be applied to intricate multi-stage manufacturing processes was developed. Probabilities for system events such as blocking, starving, stock outs and system availability were derived.

Reference [24] developed heuristics to analyse a number of systems, including merging lines, in terms of costs under rigid

demand conditions. Lower and upper control limits were set to ensure that stations do not process lots that are too small (generating high costs), or too large (generating undesirable surplus). They concluded that expected costs could be calculated for any multistage system through the solving of a finite set of linear equations.

In summary, the area of unpaced unbalanced merging assembly lines is a rather less researched field. We can see that very few studies have been carried out to investigate performance and operation of merging lines with unequal processing times. It can be noted that the approach taken was often with the aim of generating mathematical models and there have been no explicit goals of 1) investigating whether unbalancing parallel workstation MTs can yield better results from using a fixed line MT rate, 2) systematically looking at whether the various patterns of parallel workstation MTs have a significant impact on performance, and 3) performing statistical analysis to study the effects of different design factors (line length, buffer capacity imbalance degree and pattern of MT imbalance) on the merging line efficiency.

III. MOTIVATION AND OBJECTIVES

The main objective of this investigation is to assess the performance. This investigation focuses on merge lines having one source of imbalance caused by allowing MTs to differ amongst stations. The two other variables, buffer capacity (BC), and coefficient of variation (CV) are set so that all buffers along the line have the same capacity and all CVs are held equal. In addition, the simulations concern 5- and 8-station lines with three degrees of MT imbalance (the difference in MT between adjacent stations).

The main objective of this research is to assess the performance of unpaced merge lines for various patterns of MT imbalance in terms of two performance indicators; throughput (TR) and average buffer level (ABL). The research questions to be addressed are as follows:

1. What is the influence of the pattern of MT imbalance on the performance of the merging lines simulated compared to that of an equivalent balanced line?
2. Which of the patterns simulated lead to the best performance?
3. What are the relative contributions of MT imbalance pattern, imbalance degree, line length and buffer capacity to performance?

To our knowledge, there have been no previous studies which explicitly address the above three research questions.

IV. RESEARCH METHODOLOGY AND EXPERIMENTAL DESIGN

In view of the fact that no mathematical method can currently assess the more realistic and complex serial flow merging lines, typically reported with positively skewed operation times, computer simulation was viewed as the most suitable tool for this study. The unbalanced merging line behaviour was studied using a ProModel Version 7.5 coded manufacturing simulation model.

A. Factorial Design

A full factorial design was deemed to be the most apt for the current study. For the specific line studied, the independent variables used were:

A full factorial design was deemed to be the most apt for the current study. For the specific merging line studied, the independent variables used were:

- Line length (number of stations), N.
- Capacity of each buffer, BC
- Degree of unbalanced service time means, DI
- The percentage difference in MT between successive stations
- MT imbalance pattern, MTP (for parallel lines 1 and 2).

In order to simulate more realistic processing times, a right-shifted Weibull distribution was employed. Reference [25] reported that the unpaced service times found in real practice are more closely described by this probability distribution.

B. Performance Measures and Statistical Tools

Two performance measures were used in this investigation, namely; line throughput (TR) and average buffer level (ABL) for the whole line. Evidently, the study goals are to find conditions which increase TR and/or reduce ABL.

The following statistical techniques were used to analyse the TR and ABL data:

- Multiple comparisons with control using the Dunnett's t-test for comparison of the performance of unbalanced lines to the balanced line control.
- Multiple pairwise comparisons (Tukey's HSD) to compare the relative performance of unbalanced MT patterns at different BC and DI levels.
- Generalized Linear Model (GLM) analysis to identify the relative contributions of the independent variables to the dependent variable performance.

Statistical analyses were carried out using SPSS V20.

C. Simulation Run Parameters

To ensure that observations are independent, minimum autocorrelation values of between -0.20 and +0.20 should be achieved, in accordance with [26] and [27]. A trial procedure has established that after an initial run of 20,000 minutes, acceptable autocorrelation values of between -0.163 and +0.153 were achieved, leading to the conclusion that adjacent blocks were relatively independent. In order to ensure more valid statistical data, this initial warm up period was extended to 30,000 minutes. All data collected during the first 30,000 minutes were discarded and a production run of 20,000 minutes, broken down into 50 blocks (sub-runs) of 400 minutes each was gathered. This resulted in mean TR and ABL values being calculated every 400 minutes and the average of these 50 mean values (the grand mean) was computed with the objective of reducing serial correlation to a negligible level. All simulation runs used the same random number seed in order to generate an identical event sequence for all the designs and highlight the contrast amongst the configurations.

D. Line Design

For both parallel lines 1 and 2, the line lengths investigated were $N = 5$ and $N = 8$, (odd and even numbers). Also, the buffer capacity was allocated evenly between all workstations and set at $BC = 1, 2$ and 4 units. In addition, the CV for each station was fixed at 0.274 . Furthermore, the mean processing time base case was set at 10 minutes and the degrees of MT imbalance were set at $DI\% = 2, 5$ and 12 , with 2 reflecting a very slight imbalance and 12 representing a relatively high level of imbalance. For example, in the case of $N = 5$, if the pattern is a monotone increasing order (/) and $DI\% = 5$, the MTs at the five stations would be: station 1 (9.025 minutes); station 2 (9.500); station 3 (10.000); station 4 (10.500); and station 5 (10.975 minutes).

With regard to the configuration of mean time imbalance, five different patterns were considered for each of parallel lines 1 and 2:

- A balanced line arrangement (--).
- A monotone decreasing order (\) - going from slowest to fastest operators.
- A monotone increasing order (/) - going from fastest to slowest operators.
- An inverted bowl arrangement (^) - the slowest operators placed in the middle.
- A bowl arrangement (V) - the fastest operators positioned in the middle.

The use of the above 4 unbalanced patterns (descending, ascending, inverted bowl and bowl) involved the station with the slowest operation time (bottleneck or constraint station) being located at the front of the line, the end of the line, the middle of the line and simultaneously at both ends of the line.

Overall, the number of simulation runs carried out were 2 line lengths x 3 BC levels x 3 DI levels x 24 MT imbalance patterns = 432 cells + 6 balanced, for a total of 438 cells.

E. Model Assumptions

Several relatively standard assumptions for the type of lines being studied were made. These are:

- The last station is never blocked and the first station is never starved.
- All the stations are reliable.
- Only one type of product flows in the system, with no changeovers and no defective parts being produced.
- Time to move the work units in and out of the storage buffers is negligible, hence ignored.

V. SIMULATION RESULTS AND DATA ANALYSIS

The results for the two performance indicators, TR and ABL, are displayed in Tables I and II, followed by a presentation of the statistical analyses performed and an interpretation of the results. The TR and ABL data given are for the best patterns only. Full results are available from the authors upon request.

The mean values (grand mean of 50 measurements) of the performance indicators TR and ABL are presented in Tables I and II, and form the entry of each cell in the tables. For ease of reading, TR values which are higher, and ABL values that are

lower than the values for the balanced line are marked in bold and highlighted in green, indicating positive performance. Significant differences with the balanced control line (--), analysed using Dunnett's t-test are indicated with asterisks.

A. What Is the Influence of the Pattern of MT Imbalance on the Performance of the Lines Simulated Compared to That of an Equivalent Balanced Line?

In order to test the effect of MT imbalance patterns, multiple comparisons with control using the Dunnett's t-test were performed on the TR and ABL data at each level of N , BC and DI , comparing them to corresponding means obtained for equivalent balanced control. Those results differing significantly from the balanced line performance data are flagged with asterisks in Tables I and II.

It was found that a balanced arrangement is generally the best as far as TR is concerned, although on a number of occasions (especially at $DI\% = 2$ and $N = 5$), some unbalanced patterns seemed to outperform the balanced configuration, but none of them was found to be statistically significant. It can also be noted that at a low degree of MT imbalance ($DI\% = 2$), the balanced line is not significantly superior to the unbalanced patterns. However, at a higher MT imbalance level ($DI\% = 12$), the unbalanced patterns in most cases perform much worse than the balanced control.

TABLE I
 TR DATA FOR THE BEST RESULTS,

MT Pattern	N=5			N=8		
	BC=1			BC=1		
	DI=2	DI=5	DI=12	DI=2	DI=5	DI=12
--, V	0.898	0.896	0.888	0.896	0.900	0.886**
--, \	0.900	0.899	0.899	0.892	0.888	0.875**
V, V	0.897	0.895	0.875**	0.891	0.891	0.870**
\, \	0.902	0.896	0.884	0.894	0.885	0.865***
Balanced (--, --)	.900			0.898		
MT Pattern	BC=2			BC=2		
	DI=2	DI=5	DI=12	DI=2	DI=5	DI=12
	--, V	0.936	0.931	0.917	0.935	0.937*
--, \	0.943	0.938	0.928	0.936	0.929	0.899***
V, V	0.936	0.930	0.905**	0.936	0.928	0.910**
\, \	0.938	0.933	0.926	0.934	0.929	0.904***
Balanced (--, --)	.934			0.938		
MT Pattern	BC=4			BC=4		
	DI=2	DI=5	DI=12	DI=2	DI=5	DI=12
	--, V	0.963	0.956	0.927***	0.961*	0.961
--, \	0.969	0.962	0.927***	0.965	0.956	0.917***
V, V	0.965	0.956	0.926***	0.963	0.955	0.928***
\, \	0.968	0.958	0.925***	0.961	0.953	0.916***
Balanced (--, --)	.964			0.966		

* $p < 0.05$, ** $p < 0.01$, *** $p < 0.001$

For ABL on the other hand, it was found that the descending order (\, \) MT pattern largely outperforms the balanced line. Very highly significant improvements over the balanced line are obtained, especially for the higher N , BC , and DI values explored, whereas the ascending order pattern

(/, /) performs significantly worse than the control in the vast majority of situations.

B. Which of the Patterns Simulated Lead to the Best Performance?

To provide a general ranking of the patterns for overall performance, multiple pairwise comparisons (Tukey's HSD) comparing the imbalance patterns across all values of N, BC and DI to the equivalent balanced line were performed. The results support the subjective reading of Tables II-V using Dunnett's t-test. A general summary of these results is displayed in Table III (p = 0.000).

The immediate conclusion to be noted here is that the patterns of imbalance giving the best performance are different for TR on one hand and ABL on the other. Overall, for TR we can see that the best configuration is a balanced line (--, --). Moreover, the best imbalance patterns are balanced

line + bowl-shaped, balanced + inverted bowl, bowl + bowl, and inverted bowl + inverted bowl MT configurations. In many cases, they perform as well as the balanced line, so should a balanced line arrangement prove to be unattainable in practice, the best unbalanced patterns, might be used as alternatives. On the other hand, the ascending + ascending MT pattern and any combinations with ascending or descending order, all perform significantly worse than the balanced line in terms of TR. In the case of ABL, however, the results indicate that the descending + descending MT order as well as any combinations with a descending order, clearly show the best performance, outperforming the ABL performance of a balanced control. We can also observe that the ascending + ascending MT pattern, together with any combinations with ascending order perform significantly worse than the control in the majority of cases.

TABLE II
 ABL DATA FOR THE BEST RESULTS

MT Pattern	N=5			N=8		
	BC=1			BC=1		
	DI=2	DI=5	DI=12	DI=2	DI=5	DI=12
\, \	0.565	0.495***	0.383***	0.551**	0.451***	0.380***
\, --	0.565	0.523**	0.507***	0.570	0.516***	0.520***
\, Λ	0.567	0.545*	0.494***	0.551*	0.541***	0.495***
\, V	0.577	0.528***	0.485***	0.567	0.524***	0.519***
--, \	0.588	0.529**	0.504***	0.589	0.529***	0.511***
Λ, \	0.580	0.545*	0.503***	0.572*	0.525***	0.470***
Balanced (--, --)	0.594			0.604		
MT Pattern	BC=2			BC=2		
	DI=2	DI=5	DI=12	DI=2	DI=5	DI=12
	0.991*	0.896***	0.783***	1.119	0.964***	0.800***
\, --	1.105	1.015**	1.005***	0.990	0.963***	1.023*
\, Λ	1.053**	0.970**	0.986**	1.095	0.930***	0.977***
\, V	1.105	1.019*	0.927***	1.055	1.005**	1.034*
--, \	1.051	0.997**	0.968***	1.100	0.991***	1.035*
Λ, \	1.090**	0.955**	1.002**	1.014	0.964***	1.002***
Balanced (--, --)	1.120			1.123		
MT Pattern	BC=4			BC=4		
	DI=2	DI=5	DI=12	DI=2	DI=5	DI=12
	1.844***	1.604***	1.551***	1.948***	1.432***	1.105***
\, --	2.272**	1.895***	2.012***	2.223	1.996***	2.085**
\, Λ	1.888***	1.975***	1.999***	2.008***	1.828***	1.985***
\, V	2.264	1.808***	1.942***	2.066*	1.985***	1.981***
--, \	2.116**	2.043***	2.024***	2.379	2.009***	2.061**
Λ, \	2.198***	1.958***	1.989***	2.075***	1.971***	1.990***
Balanced (--, --)	2.382			2.254		

*p < 0.05, **p < 0.01, ***p < 0.001

TABLE III
 HOMOGENEOUS SUBGROUPS FOR PATTERN RANKING

Performance Indicator	Subgroup 1 (Best Patterns)
TR	Best = balanced line
ABL	Best = descending + descending, Combinations with descending order
	Subgroup 2 (Medium Patterns)
TR	Balanced line + Bowl, Balanced + inverted bowl, Bowl + Bowl, Inverted bowl + Inverted bowl
ABL	Balanced line, Combinations with bowl and inverted bowl
	Subgroup 3 (Worst Patterns)
TR	Worst = ascending + ascending Combinations with ascending or descending order
ABL	Worst = ascending + ascending, Combinations with ascending order

C. What Are the Relative Contributions of MT Pattern (MTP), DI, N and BC to Performance?

The Generalized linear model (GLM) analysis was carried out on the data in order to ascertain the relative contributions of the independent variables, namely N, BC, DI and MTP on the dependent variables, TR and ABL. Best fit was found for a Gaussian distribution for TR and ABL. The results of the GLM analysis are exhibited in Tables IV and V. To save space, only results for the highest (up to 0.037) significance levels are shown. Full data is available from the authors.

From Tables IV and V, it should be noted that for both TR and ABL, all of the 4 main effects (N, BC, DI and MTP) and many of the 1st to 3rd degree interactions are very highly significant at the 0.000 level.

The strongest, very highly significant effect on TR comes from the degree of MT imbalance in the line, followed respectively by the buffer capacity and MT pattern. The fourth to the 9th strongest influences come from five different 1st degree interactions and line length.

TABLE IV
GLM RESULTS FOR TR

Performance	Throughput (TR)	
Deviance	13.735	
Source (Factor)	Wald Chi-Square	Significance Level
DI	5,513.860***	0.000
BC	5,010.766***	0.000
MTP	816.920***	0.000
DI*MTP	719.942***	0.000
BC*DI	274.366***	0.000
N	45.494***	0.000
N*BC	17.994***	0.000
N*DI	10.276**	0.006
BC*MTP	40.186***	0.037

Significant at *p< 0.05, **p<0.01, ***p<0.001.

TABLE V
GLM RESULTS FOR ABL

Performance	Average Buffer Level (ABL)	
Deviance	181.390	
Source (Factor)	Wald Chi-Square	Significance Level
BC	67,415.608***	0.000
MTP	5,074.650***	0.000
BC*MTP	2,449.650***	0.000
DI*MTP	972.227***	0.000
BC*DI*MTP	462.705***	0.000
N*BC*DI*MTP	187.741***	0.000
N*BC*MTP	137.775***	0.000
DI	132.970***	0.000
N*DI*MTP	119.167***	0.000
BC*DI	100.913***	0.000
N*MTP	50.808***	0.000
N	32.796***	0.000
N*BC	19.891***	0.000

Significant at *p< 0.05, **p<0.01, ***p<0.001.

In the case of ABL, buffer capacity has the most, very highly significant impact on performance, followed by the MT pattern. We can note that the next five contributions come

from the combined one- two- and three-way factors combining MTP with other variables. Next, comes DI, followed respectively by three various interactions, line length, and finally N*BC.

A more detailed analysis regarding the individual effects of the independent variables on the dependent factors was also carried out, giving the following general conclusions:

- Degree of imbalance: increasing DI generally causes deterioration in performance for TR.
- Buffer capacity: as BC goes up, both TR and ABL tend to increase.
- Line length: no clear relationship was found among both TR & ABL and N.

VI. SUMMARY

A number of general conclusions can be drawn from the results presented in this paper. It was found that all the main merging line design factors, i.e. buffer capacity, MT imbalance pattern, degree of imbalance, and line length have very highly significant influence on TR and ABL performance influence.

The results show that when TR is considered, a balanced MTP yields the best performance in absolute terms. This agrees with the conclusion of [10] in that balancing merging lines yields superior performance. It is also in agreement with the findings of [8] for unreliable single serial lines. On the other hand, these results would not be in line with those reported for shorter three-station merging systems with two parallel feeders and an assembly station. The findings of [15] showed that an optimal arrangement is an unbalanced line, while [16] reported that greater improvements to TR are possible from lowering the processing times. In a study by [19] it was indicated that best results are likely obtained when the feeder stations are faster than the merge station.

In terms of TR, our research found that the balanced + balanced line arrangement was the best. However, it was also shown that, again, for TR, output did not differ significantly as compared to the four good unbalanced MT patterns, where there is an MT imbalance between the final feeder stations and the assembly station (e.g. balanced line + bowl and balanced + bowl). This lends support not only to the 3-station merging line results above, but also to the longer 5- and 8- station merging lines simulated in our study.

It was observed that one of the good MT patterns has turned out to be a bowl-shaped configuration (bowl + bowl). It can be argued that the bowl phenomenon (originally put forth by [3] and later supported by [2] continues to works for merging assembly lines as the bowl pattern is still doing well. The statistical tests however, show that unbalancing the line using a number of unbalanced MT patterns, including balanced line + bowl, balanced + inverted bowl, bowl + bowl, and inverted bowl + inverted bowl does not generally cause a significant deterioration in performance.

When we observe the results in terms of ABL performance, the pattern giving rise to the lowest ABL is a descending + descending MT order. This agrees with the conclusion of [4] for single lines in series that placing the constraint station at

the first location resulted in the lowest amount of WIP. It is also similar to the findings for a single reliable single line performance in the work of [2].

It should be noted that for the pattern giving the best ABL results, consistent, mostly highly significant improvements over the balanced line are obtained for practically all the N, BC, and DI values explored.

In addition to the effects of patterns of MT imbalance, if we now turn to the relative effect of the design factors, the GLM analysis showed us that in general BC and MTP both have very big effects on both TR and ABL performance.

It can be observed that as buffer capacity along the unbalanced merging line increases, throughput tends to rise. The general effect of higher buffer availability on ABL is to worsen performance for the unbalanced merging lines.

In terms of performance enhancement, it should be noted that the greatest % improvements in TR over the balanced merging line counterpart is 0.96% (not statistically significant). This was obtained for the pattern balanced + inverted bowl, with a TR of 0.943 compared to 0.934 for the balanced merging line, at low levels of N, BC and % DI (N = 5, BC = 2 and %DI = 2). On the other hand, the highest % superiority in ABL over an equivalent balanced merging line configuration is 50.98% (very highly significant) has been achieved for the pattern descending + descending, with an ABL of 1.105 in comparison with 2.254 for the balanced line, at relatively high levels of N, BC and %DI (N = 8, BC = 4 and %DI = 12).

VII. DISCUSSION AND CONCLUSIONS

The principal aim of this study was to assess the effect that unbalancing service mean times has on the efficiency of a merging production line.

Companies spend billions of dollars every year on the design, installation, operation, and maintenance of merging assembly lines, so even the slightest improvement in efficiency or reduction in inventory costs can result in substantial savings over the lifetime of a line.

It can be pointed out that merging production lines combining man and machine are widespread throughout the world. Achieving a balanced line where all workstations possess equal operating times is unlikely in the global context of outsourcing to countries with low labour costs, because untrained operators recruited on an ad-hoc project basis will not necessarily have the time or motivation to perform consistently. Therefore, it is important to gain understanding of how best to manage unbalanced merging assembly lines with all the sources of variability that can arise.

In view of the fact that a notionally balanced merging line is virtually unattainable in practice, i.e. most assembly lines suffer from a certain degree of imbalance, and that bottlenecks are viewed in general as a universal characteristic of real-life flow lines, it would make sense for production managers to examine the pros and cons of deliberately unbalancing a line.

This investigation has shown that in some cases statistically equivalent performance to that achieved by a balanced merging line in terms of throughput, and in many cases

statistically superior performance for average buffer level are attainable. When ABL is considered, the savings obtained are very significant (around 51% for the best case). This would appear to justify unbalancing merging assembly lines in many situations, especially since the improvement in average buffer level only requires appropriately assigning line operators to the same stations, which does not entail any further expenditure on capital or other resources. In spite of this, the results do raise a dilemma. A line manager will have to make decisions as to where the greatest benefits can be reaped. It may be to enhance throughput, for instance in an industry where demand is high and operators are working full out, such as on the production lines in consumer goods (e.g. computer, mobile phones), or where manpower is expensive. In these cases, where productivity loss can lead to great expense, the best or other favourable unbalanced mean processing time designs (such as the balanced + bowl pattern), might be selected to get the largest possible throughput improvement. If, on the other hand, the principal aim is lean buffering, as in the automotive and electronics industry, where just-in-time management requires it, the best (descending + descending) or some other advantageous unbalanced patterns (such as bowl + inverted bowl configuration) which bring average buffer levels down, would be the most appropriate.

As with all research of this nature, it should be emphasized, though, that the results here are based on a series of simulations with strictly controlled conditions and merge line characteristics on only a limited number of configurations among an almost infinite number of alternatives for unbalancing the line were examined. Therefore, if the line is imbalanced in the wrong way, it could lead to adverse performance.

Several avenues for future research are possible in this area. One research field is the study of merging lines with two or three joint sources of imbalance (e.g. mean service time and buffer capacity imbalance combined). Another possibility includes investigations aimed at assessing the effectiveness of unreliable merging assembly lines. A third possibility is to study unbalanced disassembly lines.

REFERENCES

- [1] H. Tempelmeier, "Practical considerations in the optimization of flow production systems," *International Journal of Production Research*, vol 41, no.1, pp. 149-170, 2003.
- [2] S. Shaaban and T. McNamara, "Improving the efficiency of unpaced production lines by unbalancing service time means," *International Journal of Operational Research*, vol. 43, no. 3, pp. 346-361, 2009.
- [3] F. S. Hillier and R. W. Boling, "The effect of some design factors on the efficiency of production lines with variable element times," *Journal of Industrial Engineering*, vol. 17, no. 12, pp. 651-658, 1966.
- [4] S. N. Kadipasaoglu, W. Xiang, S. F. Hurley and B. M. Khumawala, "A study on the effect of the extent and location of protective capacity in flow systems," *International Journal of Production Economics*, Vol. 63, No. 3, pp. 217-228, 2000.
- [5] B. Das, J. M. Sanchez-Rivas, A. Gacia-Diaz and C. A. MacDonald, "A computer simulation approach to evaluating assembly line balancing with variable operation times," *Journal of Manufacturing Technology Management*, vol. 2, no. 7, pp. 872-887, 2010.
- [6] M. Hillier, "Designing unpaced production lines to optimize throughput and work-in-process inventory," *IIE Transactions*, vol. 45, no. 5, pp. 516-527, 2013.

- [7] C. E. Lopez, "Unbalanced workload allocation in large assembly lines," MS dissertation, *Department of Industrial and Systems Engineering, Rochester Institute of Technology*, 2014.
- [8] S. Shaaban, T. McNamara and S. Hudson, "Mean time imbalance effects on unreliable unpaced serial flow lines," *Journal of Manufacturing Systems*, vol. 33, no. 3, pp. 357-365, 2014.
- [9] S. Hudson, T. McNamara and S. Shaaban, "Unbalanced lines – where are we now?" *International Journal of Production Research*, IE Transactions, vol. 53, no. 6, pp. 1895-1911, 2015.
- [10] H. Gökçen, A. Kürşad and B. Recep, "Balancing of parallel assembly lines", *International Journal of Production Economics*, vol, 103, no. 2, pp. 600-609, 2006.
- [11] L. E. Moberly and F. P. Wyman, "An application of simulation to the comparison of assembly line configurations," *Decision Sciences*, vol. 4, no. 4, pp. 505-516, 1973.
- [12] K. E. Maani and G. L. Hogg, (1980) "A stochastic network simulation model for production line systems," *International Journal of Production Research*, vol. 18, no. 6, pp. 723-739, 1980.
- [13] X-G. Liu and J. A. Buzacott, "Approximate models of assembly systems with finite inventory banks," *European Journal of Operational Research*, vol. 45, pp. 143-154, 1990.
- [14] K. R. Baker, S. G. Powell and D. F. Pyke, "Buffered and un-buffered assembly systems with variable processing times," *Journal of Manufacturing and Operations Management*, vol. 3, pp. 200-223, 1990.
- [15] K. R. Baker, S. G. Powell and D. F. Pyke, "Optimal allocation of work in assembly systems," *Management Science*, vol. 39, pp. 101-106, 1993.
- [16] R. Bhatnagar and P. Chandra, "Variability in assembly and competing systems: effect on performance and recovery," *IIE Transactions*, vol. 26, no. 5, pp. 18-31, 1994.
- [17] K. R. Baker and S. G. Powell, "A predictive model for the throughput of simple assembly systems," *European Journal of Operational Research*, vol. 81, pp. 336-345, 1995.
- [18] S. G. Powell and D. F. Pyke, "Buffering unbalanced assembly systems," *IIE Transactions*, vol. 30, pp. 55-65, 1998.
- [19] M. J. Magazine and K. E. Stecke, "Throughput for production lines with serial work stations and parallel service facilities," *Performance Evaluation*, vol. 25, pp. 211-232, 1996.
- [20] K-C. Jeong and Y-D. Kim, "Technical note: an approximation method for performance analysis of assembly/disassembly systems with parallel-machine stations," *IIE Transactions*, vol. 31, pp. 391-394, 1999.
- [21] B. Tan, "A three-station merge system with unreliable stations and a shared buffer," *Mathematical and Computer Modelling*, vol. 33, pp. 1011-1026, 2001.
- [22] I. Sabuncuoglu, E. Erel and A. G. Kok, "Analysis of assembly systems for interdeparture time variability and throughput", *IIE Transactions*, vol. 34, pp. 23-40, 2002.
- [23] X-M. Yuan and L. Liu, "Performance analysis of assembly systems with unreliable machines and finite buffers", *European Journal of Operational Research*, vol. 161, pp. 854-871, 2005.
- [24] A. Grosfeld-Nir and T. Ben-Zvi, "Multistage production systems with random yields and rigid demand", *International Journal of Manufacturing Technology and Management*, vol. 20, Nos.1-4, pp. 286-299, 2010.
- [25] N. Slack, "Work time distributions in production system modelling", research paper, *Oxford Centre for Management Studies*, 1982.
- [26] C. Harrell, B. K. Ghosh and R. O. Bowden, *Simulation using ProModel*, New York, McGraw – Hill, 2004.
- [27] A. M. Law, *Simulation Modeling and Analysis*, Illinois, Irwin / McGraw-Hill, 2007.