

# Medical Image Edge Detection Based on Neuro-Fuzzy Approach

J. Meheena, M. C. Adhikary

**Abstract**—Edge detection is one of the most important tasks in image processing. Medical image edge detection plays an important role in segmentation and object recognition of the human organs. It refers to the process of identifying and locating sharp discontinuities in medical images. In this paper, a neuro-fuzzy based approach is introduced to detect the edges for noisy medical images. This approach uses desired number of neuro-fuzzy subdetectors with a postprocessor for detecting the edges of medical images. The internal parameters of the approach are optimized by training pattern using artificial images. The performance of the approach is evaluated on different medical images and compared with popular edge detection algorithm. From the experimental results, it is clear that this approach has better performance than those of other competing edge detection algorithms for noisy medical images.

**Keywords**—Edge detection, neuro-fuzzy, image segmentation, artificial image, object recognition.

## I. INTRODUCTION

EDGES in a digital image provide important information about the boundary or contour where an abrupt change occurs in some physical aspect such as gray level value of an image. Edge detection is a frequently performed operation in many image processing applications because it is usually the first operation that is performed before other image processing tasks such as object recognition, boundary detection, image registration and image segmentation [1]. Consequently, the success of these subsequent image processing tasks is strictly dependent on the performance of the edge detection operation. Medical image edge detection is an important work for object recognition of the human organs and it is an essential pre-processing step in medical image segmentation [2]. The work of the edge detection decides the result of the final processed image. Classical methods of edge detection involve convolving the image with an operator (a 2-D filter), which is constructed to be sensitive to large gradients in the image while returning values of zero in uniform regions. There are an extremely large number of edge detection operators available, each designed to be sensitive to certain types of edges. Variables involved in the selection of an edge detection operator include edge orientation, noisy environment and edge structure. There are two main types of edge detector: one is the first derivative based edge detection operator to detect image edges by computing the image gradient values, such as Roberts, Sobel and Prewitt operator; the other one is the

second derivative based edge detection operator to detect edges by taking second derivative such as LOG and Canny operator [3], [4].

The first order derivative like Sobel, Prewitt and Laplacian of Gaussian operator, but in theory they belong to the high pass filtering, which are not fit for noisy medical image edge detection because noise and edge belong to the scope of high frequency. In real world applications, medical images contain object boundaries and object shadows and noise. Therefore, they may be difficult to distinguish the exact edge from noisy medical images. These detectors are simple to implement but they are usually inaccurate and highly sensitive to noise. The second order detects edges by taking second derivative and is very sensitive to noise too. The Gaussian edge detectors reduce the undesirable negative effects of noise by smoothing the image before performing edge detection [18]. Hence, they exhibit much superior performance over other operators especially in noisy conditions. The Canny detector [5], which is a Gaussian edge detector, is one of the most popular edge detectors and it has been widely used in many applications. Although the Gaussian detectors exhibit relatively better performance, they are computationally much more complex than classical derivative based edge detectors. Furthermore, their performances quickly decrease as the density of the corrupting noise increases.

Mathematical morphology is a new mathematical theory which can be used to process and analyse the medical images [6]-[8]. It provides an alternative approach to image processing based on shape concept stemmed from set theory, not on traditional mathematical modelling and analysis. In the mathematical morphology theory, images are treated as sets, and morphological transformations which derived from addition and subtraction are defined to extract features in images. As the performance of classic edge detectors degrades with noise, morphological edge detector has been studied. It is a better method for edge information detecting and noise filtering than differential operation, which is sensitive to noise. This method is a better compromise between noise smoothing and edge orientation, but the computation is more complex than general edge detection algorithms. Therefore, a novel edge detector that is capable of extracting edges from medical images corrupted by noise is highly desirable.

Fuzzy logic based approach can deal with the ambiguity and uncertainty in image processing in better way as compared to the traditional approaches [9]-[14]. When fuzzy logic is used for edge detection gives better result compare to the classical approach. The classical techniques like Sobel, Prewitt, Roberts, Canny edge detector have limitations of

J. Meheena, Research Scholar, and M.C. Adhikary, Professor, are with the Department of Applied Physics and Ballistic is with Fakir Mohan University, Balasore, Odisha, India (e-mail: j\_meheena@rediffmail.com, mcadhikary@gmail.com).

using fixed value of parameters or threshold. The nature of edges is not constant due to which few edges left by being detected. However, as the medical image gets complex, different local areas will need different threshold values to accurately find the real edges. In addition, the global threshold values are determined manually through experiments in the traditional method, which leads complex in calculation when large number of different medical images needs to be dealt with. Fuzzy logic is a soft computing technique that provides us flexibility by allowing the values without any such restrictions. Fuzzy logic has IF-THEN rules and has simple structure to implement and also this logic is a logical system which is an extension of multi valued logic. It is a propositional calculus in which there are more than two truth values. By using fuzzy techniques edges having different thickness can also be detected [19]. Fuzzy logic is conceptually easy to understand, flexible and is tolerant of imprecise data. Fuzzy logic is to map an input space to an output space and for doing this a list of if then statements called rules are evaluated in parallel. These rules are useful because they use variables and adjectives that describe those variables. This approach works well in noisy condition and significantly detects more edges as compared to the traditional approaches, but still the edges are not clearly identified.

In this paper, we extend our research on neuro-fuzzy (NF) approach for detection of edges in medical images. This approach is suitable to deal with uncertainty in the process of extracting useful information from noisy images. The NF systems combine the ability of neural networks to learn and the capability of fuzzy logic systems to model the uncertainty. Hence, NF systems may be employed as powerful tools for edge detection provided that appropriate network topologies and training strategies are chosen. In the proposed method, the edges in the noisy image are directly determined by a NF network without needing a pre-filtering of the noisy input image. The NF system consists of a number of subdetectors and a postprocessor. Each sub-detector evaluates a different pixel neighborhood in the filtering window. The proposed NF edge detector is tested on various medical images having different image properties and also compared with popular edge detection algorithm. The proposed NF edge detector exhibits much better performance than the competing operators and may efficiently be used for the detection of edges in medical images corrupted by various noises.

The rest of this research paper is organized as follows. In Section II, the proposed approach for medical image edge detection is described in details. Experimental results and comparison with existing edge detection methods are presented in Section III. Finally, conclusions followed by references come in Section IV.

## II. PROPOSED APPROACH

The proposed approach uses a desired number of NF subdetectors with a postprocessor. Fig. 1 shows the general structure of the proposed NF edge detection operator. The NF subdetector used in this work operates on the 3x3 window. Each subdetector evaluates a different neighborhood relation

between the center pixel of the filtering window and two of its neighbors. The coefficients and possible edge directions for 3x3 windows are shown in Fig. 2. The higher the number of NF sub-detectors, the better the edge detection performance, but the higher the computational cost.

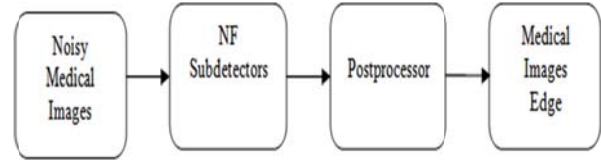

Fig. 1 The general structure of the proposed NF edge detection operator

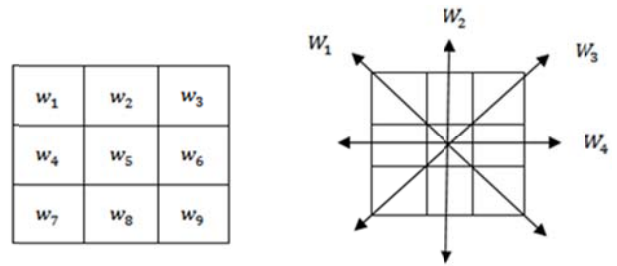

Fig. 2 Coefficients and possible edge directions for 3x3 window

### A. Neuro-Fuzzy (NF) Subdetectors

The proposed NF subdetector is a first-order Sugeno type fuzzy inference system with 3-inputs and 1-output. The NF subdetector uses in this work are identical to each other. Each input has 3 triangular type membership functions and the output has The NF subdetector uses in this work are identical to each other. Since the NF subdetector has 3 inputs and each input has 3 membership functions, the rule base contains a total of 27 rules.

In this paper, we use the triangular membership function and uses singleton fuzzifier and Sugeno inference system. The input membership functions are generalized triangular type.

$$\mu_{tri}(x) = \begin{cases} x - a / b - a, & a \leq x < b \\ c - x / c - b, & b \leq x < c \end{cases} \quad (1)$$

Here the parameters  $a, b$  and  $c$  are constants that characterize the shape of the membership functions. The fuzzy rules are applied to the inputs and then the output can be found by calculating the weighted average of the individual rule outputs.

$$Y = \frac{\sum_{k=1}^{27} w_k R_k}{\sum_{k=1}^{27} w_k} \quad (2)$$

where,  $R_k$  denotes the output of the  $k$ th rule and  $w_k$  is the weighting factor of each rule is calculated by evaluating the membership expressions in the antecedent of the rule. This is accomplished by first converting the input values to fuzzy membership values by utilizing the input membership functions and then applying the *and* operator to these membership values. The *and* operator corresponds to the multiplication of input membership values.

### B. Post-Processor

The NF subdetectors outputs are fed to the postprocessor, which generates the final NF network output. The postprocessor actually calculates the average value of the subdetector outputs and compares this value with a threshold. The threshold value is the half of the available dynamic range for the pixel luminance values. For 8-bit images, where the pixel values range between 0 and 255, the threshold value is 128. The outputs of the NF subdetectors truncate this value to 0 or 255. The value obtained at the output of the postprocessor is also the output value of the NF edge detector and represents the decision whether the centre pixel of the filtering window is an edge pixel or not.

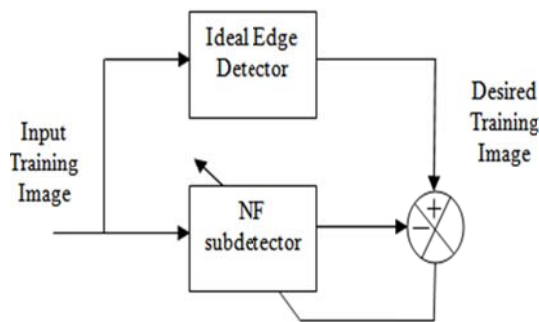

Fig. 3 Training of the subdetectors

Each NF subdetector is trained individually and the parameters of the edge detector are optimized by training. Fig. 3 represents the setup used for training of the subdetectors. The parameters of the NF subdetectors under training are iteratively adjusted so that its output converges to the output of the ideal edge detector which, by definition, can correctly detect the locations of the edge pixels of the image fed to its input. The ideal edge detector is conceptual only and does not necessarily exist in reality. It is only the output of the ideal edge detector that is necessary for training, and this is represented by the desired training image. It is a black and white image and its black pixels indicate the locations of the true edges of the input training image. Hence it represents the output of the ideal edge detector for the input training images. The parameters of the subdetectors under training are then tuned by Levenberg Marquardt based back-propagation learning algorithm [15]-[17], which minimizes the learning error.

### III. EXPERIMENTAL RESULTS

In this section experiments are made to verify the performance of neuro-fuzzy approach on different test medical images. The images that are corrupted by impulse noise are considered here. All test images are 8-bit grey level images. The noisy images used in the edge detection experiments are obtained by corrupting the original test images by impulse noise with 5% noisy density. The noisy test images are shown

in Fig. 4. The experimental results and comparison of the proposed approach with various edge detection methods such as Sobel, Canny, Morphological and Fuzzy logic approaches are shown in Fig. 5.

It is observed from Fig. 5 that the performance of the Sobel operator is very poor. For all test medical images, its output images are severely degraded by noise, most noise pulses are incorrectly detected as edges. The canny edge detector demonstrates a considerably better performance than the Sobel detector. It correctly detects most of the noise pulses. However, the effect of noise is still clearly visible as real edges are significantly distorted by the noise. The morphological edge detector removes most of the noise, but the edges are not clearly identified. On the other hand, the fuzzy logic approach exhibit very good detection performance and still the edges are not identified properly and the proposed approach successful detects more fine edges in all test medical images.

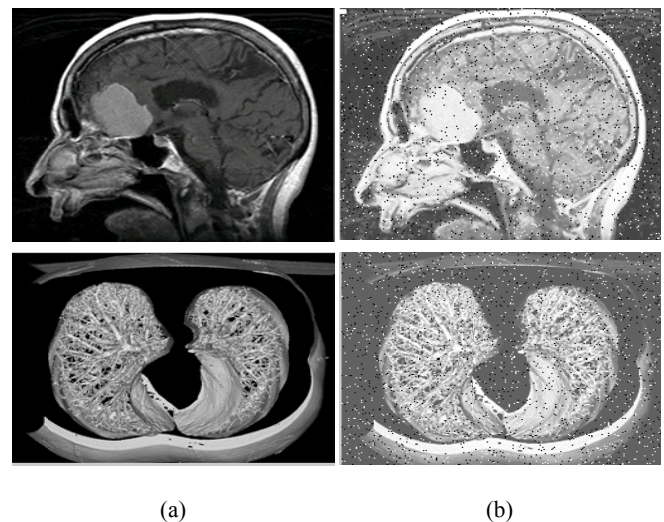

Fig. 4 Test medical images: MR images on (a) are the original image and the images on (b) are the noisy image used in the edge detection experiments

### IV. CONCLUSIONS

This paper presented a neuro-fuzzy approach to detect more fine edges of noisy medical images. In this approach, the parameters of the NF subdetectors under training are iteratively adjusted so that its output converges to the output of the ideal edge detector which, by definition, can correctly detect the locations of the edge pixels of the image fed to its input. The experimental results show that the proposed approach is more efficient for medical image denoising and edge detection than the usually edge detection methods such as Sobel, Canny, Morphological and Fuzzy logic approaches. From the experimental results it is clear that the proposed approach can be used for efficient extraction of fine edges in medical images corrupted by impulse noise.

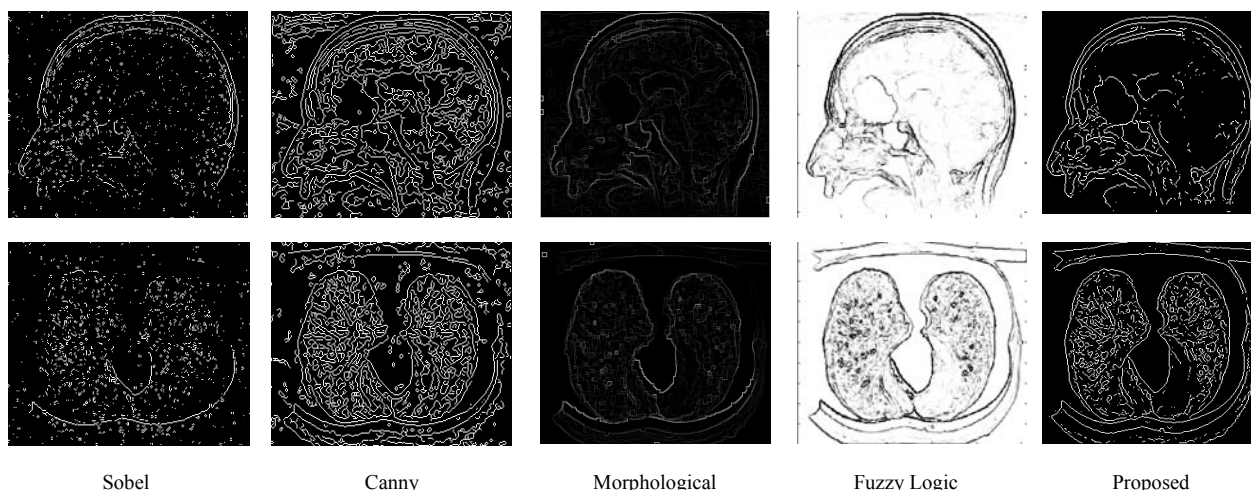

Fig. 5 Comparison of the proposed approach with Sobel, Canny, Morphological and Fuzzy logic approaches

#### REFERENCES

- [1] M.M. Subashini, S.K. Sahoo., "Pulse coupled neural networks and its applications", *International Journal of Expert Systems with Applications*, Vol.41, pp.3965-3974, 2014.
- [2] M.I. Rajab, M.S. Woolfson, and S.P. Morgan, "Application of region-based segmentation and neural network edge detection to skin lesions", *Computerized Medical Imaging and Graphics*, Vol. 28, pp.61-68, 2004.
- [3] Raman Maini and Himanshu Aggarwal, "Study and Comparison of Various Image Edge Detection Techniques", *International Journal of Image Processing (IJIP)*, Vol. 3, 20, pp.1-12, 2010.
- [4] R. C. Gonzalez, R.E. Woods and S.L. Eddins, "Digital Image Processing Using MATLAB", 2nd Edn., Mc Graw Hill, New Delhi, 2010.
- [5] J. Canny, "A Computational Approach to Edge Detection", *IEEE Transactions on Pattern Analysis and Machine Intelligence*, Vol. 8, pp. 679-687, 1986.
- [6] Jing Xiao-jun, Yu Nong, and Shang Yong, "Image Filtering Based on Mathematical Morphology and Visual Perception Principle", *Chinese Journal of Electronics*, Vol. 13, pp. 612-616, 2004.
- [7] Richard A P, "A New Algorithm for Image Noise Reduction Using Mathematical morphology", *IEEE Transaction on Image Processing*, Vol. 4, pp. 554-568, 1995.
- [8] J. Mehena, "Medical Image edge detection based on mathematical morphology", *International Journal of Computer and communication technology*, Vol. 2, pp.45-48, 2011.
- [9] Liang, L.R., Looney, C.G., "Competitive fuzzy edge detection", *Applied Soft Computing*, Vol. 3, pp. 132-137, 2003.
- [10] J. Mehena and M.C. Adhikary, "Medical Image edge detection based on soft computing approach", *International Journal of Innovative Research in computer and communication Engineering*, Vol. 3, pp.6801-6807, 2015.
- [11] Choi YS, Krishnapuram R., "A robust approach to image enhancement based on fuzzy logic", *IEEE Trans. Image Processing*, Vol.6, pp.808-825, 1997.
- [12] Abdallah A. Alshennawy, and Ayman A. Aly., "Edge Detection in Digital Images Using Fuzzy Logic Technique", *World Academy of Science, Engineering and Technology*, pp.178-186,2009.
- [13] Pushpajit A. Khaire and Nileshsingh V. Thakur, "A Fuzzy Set Approach for Edge Detection", *International Journal of Image Processing*, Vol.6, pp.403-412, 2012.
- [14] Russo, F., "Edge Detection in Noisy Images Using Fuzzy Reasoning", *IEEE Trans. On Inst. and Meas.*, Vol.47, pp.802-808, 1998.
- [15] M. T. Hagan and M. B. Menhaj, "Training feed forward networks with the Marquardt algorithm," *IEEE Trans. Neural Network.*, Vol. 5, pp. 989-993,1994.
- [16] Yuksel ME., "Edge detection in noisy images by neuro-fuzzy processing", *AEU International Journal of Communication*, Vol. 61, pp.82-89, 2007.
- [17] J. Vasavada and S. Tiwari, "An Edge detection method for grayscale images based on BP feedforward Neural network", *International Journal of Computer applications*, Vol.67, pp.23-28, 2013.
- [18] Hassanpour, H. and Asadi, S., "Image quality enhancement using pixel wise gamma correction", *International Journal of Engineering-Transactions B: Applications*, Vol. 24, No. 4, pp. 301-311, 2011.
- [19] J. Mehena and M. C. Adhikary, "Medical Image Segmentation and Detection of MR Images Based on Spatial Multiple- Kernel Fuzzy C-Means Algorithm", *International Journal of Medical, Health, Biomedical, Bioengineering and Pharmaceutical Engineering, World Academy of Science, Engineering and Technology*, Vol. 9, Issue 6, pp. 508 - 512, June-2015.