

A Large Ion Collider Experiment (ALICE) Diffractive Detector Control System for RUN-II at the Large Hadron Collider

J. C. Cabanillas-Noris, M. I. Martínez-Hernández, I. León-Monzón

Abstract—The selection of diffractive events in the ALICE experiment during the first data taking period (RUN-I) of the Large Hadron Collider (LHC) was limited by the range over which rapidity gaps occur. It would be possible to achieve better measurements by expanding the range in which the production of particles can be detected. For this purpose, the ALICE Diffractive (AD0) detector has been installed and commissioned for the second phase (RUN-II). Any new detector should be able to take the data synchronously with all other detectors and be operated through the ALICE central systems. One of the key elements that must be developed for the AD0 detector is the Detector Control System (DCS). The DCS must be designed to operate safely and correctly this detector. Furthermore, the DCS must also provide optimum operating conditions for the acquisition and storage of physics data and ensure these are of the highest quality. The operation of AD0 implies the configuration of about 200 parameters, from electronics settings and power supply levels to the archiving of operating conditions data and the generation of safety alerts. It also includes the automation of procedures to get the AD0 detector ready for taking data in the appropriate conditions for the different run types in ALICE. The performance of AD0 detector depends on a certain number of parameters such as the nominal voltages for each photomultiplier tube (PMT), their threshold levels to accept or reject the incoming pulses, the definition of triggers, etc. All these parameters define the efficiency of AD0 and they have to be monitored and controlled through AD0 DCS. Finally, AD0 DCS provides the operator with multiple interfaces to execute these tasks. They are realized as operating panels and scripts running in the background. These features are implemented on a SCADA software platform as a distributed control system which integrates to the global control system of the ALICE experiment.

Keywords—AD0, ALICE, DCS, LHC.

I. INTRODUCTION

ALICE (A Large Ion Collider Experiment) is an experiment dedicated to the study of strongly interacting matter, particularly to the study of heavy ion collisions at very

Cabanillas-Noris J. C. is with Informatics Faculty, Autonomous University of Sinaloa (UAS), Josefa Ortiz de Domínguez S/N Culiacán Rosales, Sinaloa, México, CP: 80013 (phone: +52 667 716 13; e-mail: juan.carlos.cabanillas.noris@cern.ch).

Martínez-Hernández M. I. is with Faculty of Mathematics-Physical Sciences, Autonomous University of Puebla (BUAP), Cd. Universitaria, 72570 Heróica Puebla de Zaragoza, Puebla, México (phone: +52 222 229 5500; e-mail: mario.martinez.hernandez@cern.ch).

León-Monzón I. is with Faculty of Mathematics-Physical Sciences, Autonomous University of Sinaloa (UAS), Calle Universitarios Ote., Culiacán Rosales, Sinaloa, México, CP: 80010 (phone: +52 667 758 1403; e-mail: ildefonso.leon.monzon@cern.ch).

The authors are members of the ALICE Experiment collaboration in the Large Hadron Collider (LHC).

high energies at the LHC in the European Organization for Nuclear Research (CERN) [1], [2]. The new AD0 detector is expected to expand the detection capacity for diffractive events in the ALICE experiment in proton-proton (p-p) and lead ions (Pb-Pb) collisions by adding four planes of particle counters at very small angles with respect to the beam direction. The detection of diffractive events in ALICE during the first phase of LHC operation (RUN-I) was limited by the range over which rapidity gaps were identified. AD0 will expand the range in which the production of particles (or lack thereof) can be detected [3]. Another benefit gained by the operation of the AD0 detector as a diffractive physics trigger is the larger amount of data recorded due to the fact that about 25% of the results of collision events are of the diffractive type [4]. To integrate AD0 to the ALICE data taking, it was necessary to design a new control architecture specific to this detector.

II. AD0 DETECTOR

The AD0 detector consists of two sub-detectors called ADA and ADC. Each of them comprises two detector layers, and each one is formed by four scintillator modules arranged around the LHC beam pipe. The ADA and ADC designations refer to the positions where they are installed at both ends of the ALICE experimental site with respect to the interaction point (IP). The positions of ADA and ADC in the ALICE reference frame and the nomenclature for layers and modules are shown in Fig. 1.

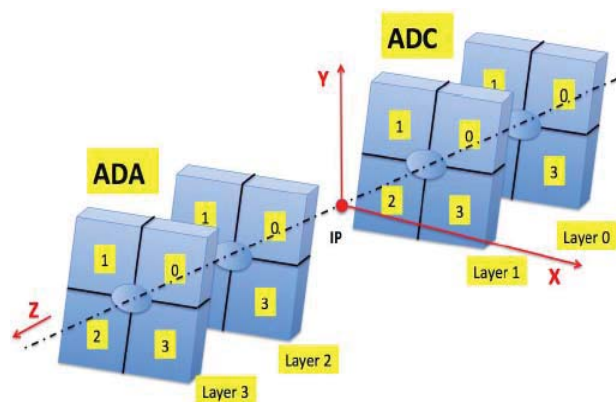

Fig. 1 ADA and ADC sub-detectors nomenclature in the ALICE cavern

Each detector module is made up of a tile of plastic

scintillator (216 mm x 181 mm x 25 mm) coupled to a pair of Wavelength shifting (WLS) bars. The light collected by the WLS bars is transmitted to a photomultiplier tube (PMT) through bunches of clear optical fibers.

Both layers of ADA and ADC are mounted on aluminum supports that hold the modules together and keep them in position around the beam pipe. One of the layers of the ADC sub-detector in its metal structure is shown in Fig. 2.

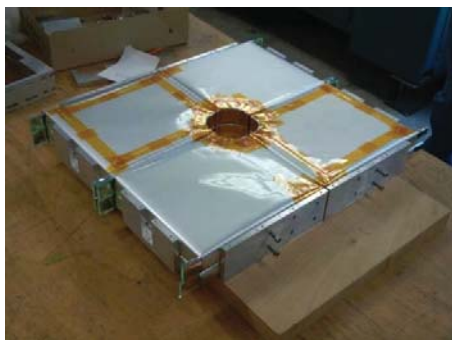

Fig. 2 AD0 detector placed in metal structure

III. DETECTOR CONTROL SYSTEM (DCS)

The DCS is responsible for controlling, monitoring and configuring the AD0 detector equipment among which there are commercial hardware devices like power supplies, voltage cards, crates, etc. as well as specific custom equipment like the Front-End Electronics (FEE). These tasks are accomplished mainly by sending commands to and reading the status from the equipment.

The DCS is designed to take pre-programmed actions and automated decisions without operator intervention, to thereby limit the risks for human error and increase efficiency [5]. Moreover, the operating environment is designed to be intuitive and user friendly. All relevant parameters for the offline analysis of physical data are configured in the AD0 DCS to be archived periodically in the central database of ALICE [6].

A. WinCC-OA ® SCADA Software

The control systems in ALICE are developed using a Supervisory Control and Data Acquisition (SCADA) platform called WinCC Open Architecture (OA) ® (formerly PVSS) from ETM Company [7]. This software was selected after a thorough evaluation of its performance by the CERN-JCOP [8]. WinCC-OA software is used by the four LHC experiments and also for the control of many services in the LHC such as gas and security systems among others.

B. JCOP Framework

The Joint Controls Project (JCOP) is a collaboration between CERN and the four LHC experiments that provides a forum for discussion and development of a common set of tools and components used to implement control systems at CERN. These tools are grouped into so-called components according to their functionality. The different components are

in time grouped as a complete single software package called the JCOP Framework [9].

C. User Interfaces

The control system for each ALICE detector provides the experiment operators with graphical user interfaces (UI) to interact with the detectors and the associated equipment. User interfaces implemented throughout the experiment have a high level of consistency for the user to perceive greater familiarity and facilitate their operation [10]. Therefore, the design of the AD0 detector interface is in agreement with the rules for user interfaces in ALICE and is made using the framework. Users having access to these AD0 detector interfaces are the DCS shifter and shift leader (SL) in the ALICE Run Control Center (ARC) and also expert AD0 operators either locally at ARC or remotely.

IV. AD0 DCS HARDWARE ARCHITECTURE

AD0 DCS has an architecture compatible with other hardware architectures in the ALICE experiment [6] which are subdivided into three layers; a) supervision, b) process control and c) field layer. The supervision layer consists of operator nodes (ON) that provide user interfaces for operators. The process control layer consists of worker nodes (WN). The field layer includes field devices such as: power supplies, crates, sensors, actuators, etc. The AD0 detector hardware architecture is described in Fig. 3.

V. SOFTWARE ARCHITECTURE OF AD0 DCS

The software architecture is a tree-like hierarchy that models the structure of the hardware sub-systems and devices. This tree structure is composed of nodes, each one having a single parent, except the top node. Nodes can have zero, one or more children. A child node without children is called leaf, and a subset of nodes in the tree is called a sub-tree. Fig. 4 shows the simplified software architecture in the AD0 DCS where the main subsystems are shown.

There are three types of nodes that serve as basic building blocks: Control Unit (CU), Logical Unit (LU) and Device Unit (DU). CUs and DUs control the sub-trees beneath them. A DU is a leaf type node and models a device. The hierarchy can have an arbitrary number of abstraction levels to provide as many layers as required. The performance and functionality of each node in the tree hierarchy is implemented as a Finite State Machine (FSM) [5].

VI. HARDWARE REQUIREMENTS

This section describes the requirements of AD0 control system in terms of high and low voltage infrastructure, in addition to electronic components. A description of the equipment used by the above subsystems and their most important configuration parameters are also presented.

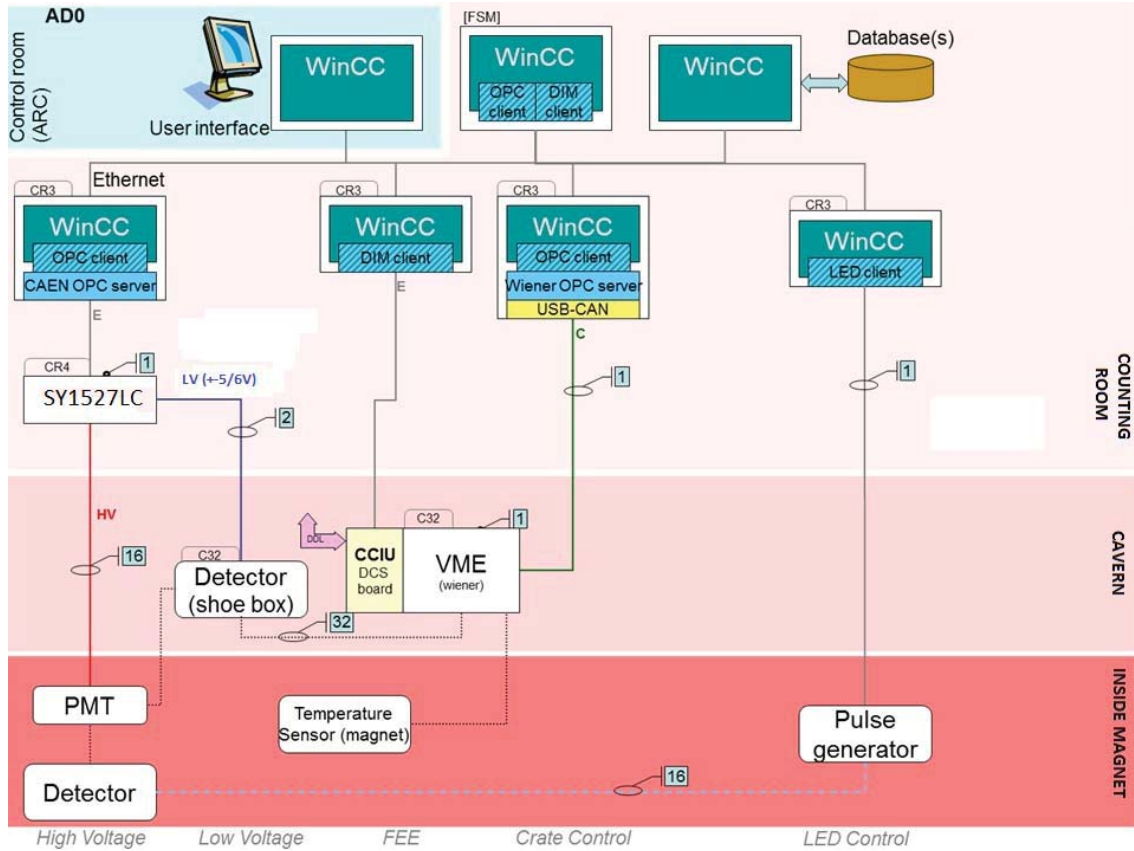

Fig. 3 Hardware architecture of AD0 DCS

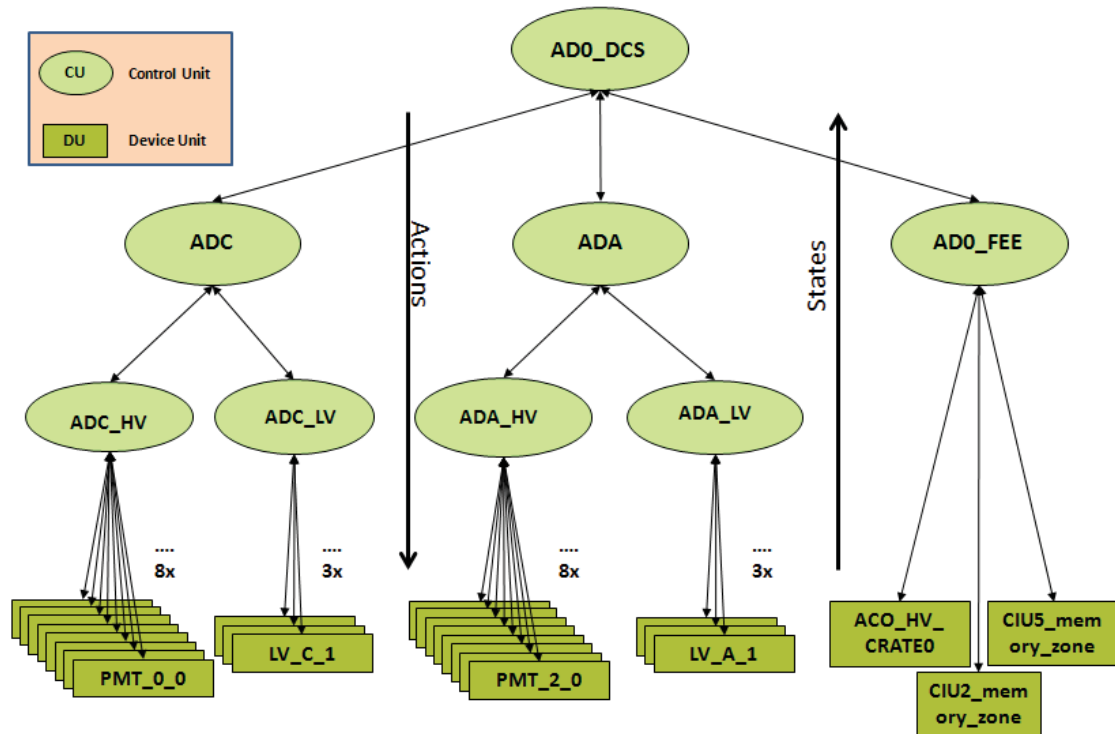

Fig. 4 AD0 DCS Software Architecture

A. High Voltage

The main device to provide the requirements of high and low voltage on the AD0 detector is an SY1527 multichannel power supply crate from CAEN® Company [11]. It is placed at the Counting Room 4 (CR4) in the ALICE experimental site. Two cards for high voltage and one for low voltage supply are inserted in the SY1527 slots. Both high voltage cards used are of the AG535DP model which has 12, high voltage common ground channels providing up to 3.5 kV with a maximum power of 6 W per channel. The first eight channels of each AG535DP card are used to power the photomultipliers from each sub-detector. The high voltage configuration in the ADC and ADA sub-detectors are shown in Tables I and II.

B. Low Voltage

The signal from each PMT is conditioned by a preamplifier and shaper. These circuits require two voltage levels: -10 V and +6 V. As in the case of the high voltage, a low voltage power supply card is inserted in the SY1527 crate. The CAEN A1513B card has six low voltage outputs (with reversible polarity) in the range of 0-10 V and able to supply up to 2.7 amp [11]. Two channels are connected in series to supply the negative voltage to the amplifiers in order to cope with the voltage drop along the very long cables from the SY1527 crate (in the CR4) to the electronics rack near the detector (down in

the ALICE cavern).

TABLE I
 CONFIGURATION OF THE HIGH VOLTAGE CARD IN THE ADC SUB-DETECTOR

PMTs Nomenclature	Channel	Crate Slot
PMT_0_0	0	
PMT_0_1	1	
PMT_0_2	2	
PMT_0_3	3	
PMT_1_0	4	1
PMT_1_1	5	
PMT_1_2	6	
PMT_1_3	7	

TABLE II
 CONFIGURATION OF THE HIGH VOLTAGE CARD IN THE ADA SUB-DETECTOR

PMTs Nomenclature	Channel	Crate Slot
PMT_2_0	0	
PMT_2_1	1	
PMT_2_2	2	
PMT_2_3	3	
PMT_3_0	4	3
PMT_3_1	5	
PMT_3_2	6	
PMT_3_3	7	

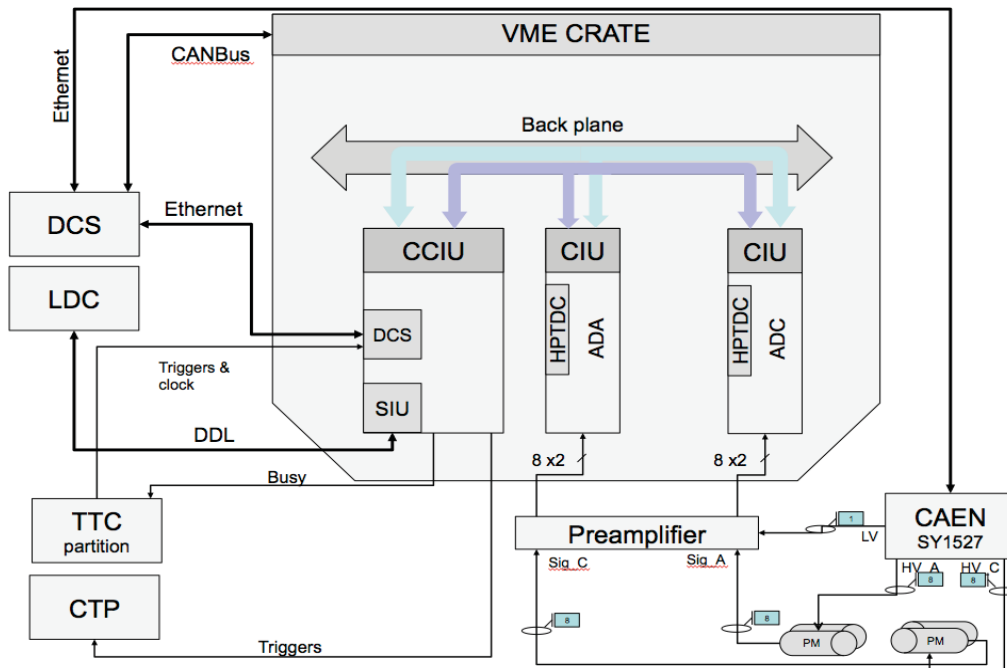

Fig. 5 Block diagram of the AD0 detector electronics

The ADA sub-detector amplifiers are fed by the first three channels in the A1513B card while the ADC sub-detector amplifiers are fed by the rest of the channels in the card. The low voltage supply configuration in the ADC and ADA sub-detectors is shown in Table III.

C. Front-End Electronics (FEE)

The AD0 detector FEE developed by the ALICE collaboration is shown in Fig. 5. These circuits generate the trigger signals for the diffractive events based on the number and identity of the modules that registered a particle hit at each collision event. The AD0 FEE circuits are also capable of

measuring the total charge collected by each module giving an estimate of the particle multiplicity. High precision time to digital converters (HPTDC) provide timing information crucial for trigger signal discrimination and for localization of the primary point of collision.

TABLE III.
 CONFIGURATION OF THE LOW VOLTAGE CARD IN THE ADO DETECTOR

Channel nomenclature	Sub-detector	Channel	Voltage	Crate Slot
LV_A_1		0	+6 V	
LV_A_2	ADA	1	-5 V	
LV_A_3		2	-5 V	8
LV_C_1		3	+6 V	
LV_C_2	ADC	4	-5 V	
LV_C_3		5	-5 V	

The ADO FEE is realized as three custom 9U VME cards installed on a powered crate from WIENER Plein & Baus GmbH. Two types of cards were designed [12]:

- Channel Interface Unit (CIU) card: Integrates and digitizes the signal coming from eight preamplifiers to obtain the charge collected by each module. It also registers the arrival time of all eight signals and digitizes them to provide timing information. Two cards of this

type are required for the readout of the 16 modules of the ADO detector.

- Channel Concentrator Interface Unit (CCIU) card: This card manages the charge and timing data produced by the two CIU cards and interfaces with the Data Acquisition System (DAQ), the Detector Control System (DCS) and the trigger system (CTP, Central trigger Processor). Clock signals are also distributed by the CCIU.

VII. IMPLEMENTATION OF ADO DCS

As it was mentioned in Section V the CU and DU nodes in the control hierarchy of ADO are implemented as finite state machines. The FSM tool built into the framework is based on the SMI++ (State Machine Interface) language. It provides means for distribution, autonomy, communication, coordination and organization of individual nodes within the tree of the control system.

The FSM Framework component allows the description of any sub-system as a collection of objects, where each object corresponds to a FSM. Every object has a list of predefined states, and for each of them a number of predefined actions (i.e. commands) are defined. Commands can be sent to other objects either to propagate them or to actually actuate on the detector equipment.

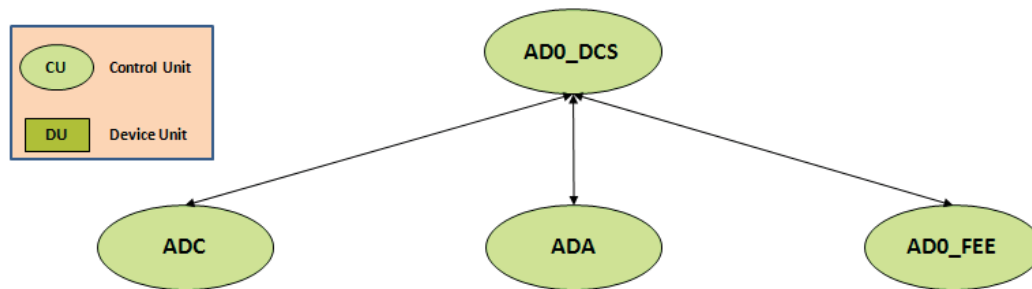

Fig. 6 FSM tree diagram of ADO nodes in the top node

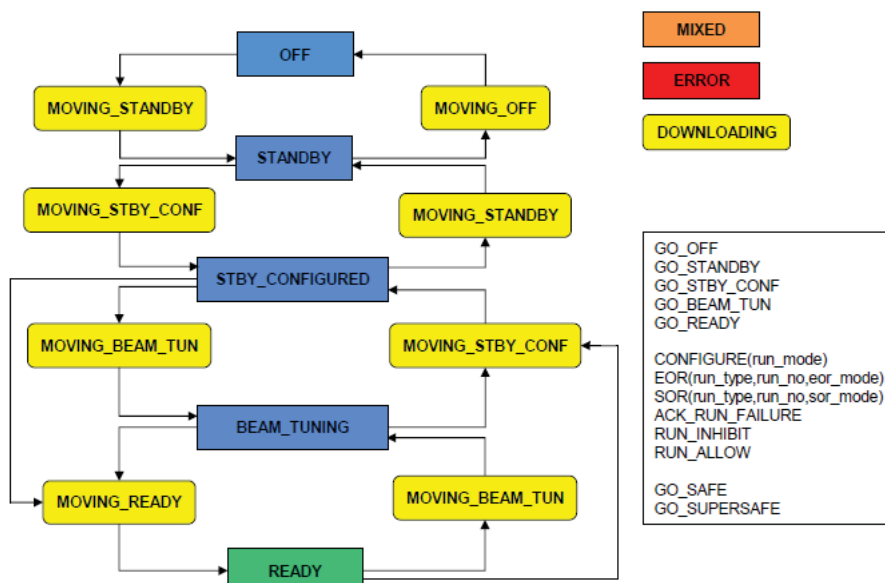

Fig. 7 FSM state diagram of the ADO top node

A group of logically related objects is called a domain in the SMI terminology.

A. FSM Nodes on the Top Levels of the Control Hierarchy

The AD0 control system is designed as a detector oriented hierarchy based on the physical components of the detector. At the highest level of the hierarchy the top node (AD0_DCS) is the main control unit (see Fig. 6).

Commands issued from any node are sent in parallel to all the nodes in the sub-tree under it (its children). The states reported by all children in this sub-tree are then synthesized at the (parent) node to reflect the overall status of the sub-tree.

Fig. 6 shows the tree diagram of AD0 FSM nodes up to the second level wherein the ADC and ADA nodes comprise the CUs and DUs for the ADC and ADA sub-detectors, respectively. Similarly, the AD0_FEE node represents a sub-tree containing the DUs for the Front-End Electronics.

ADC and ADA nodes are implemented as a control unit of

the same type while for the AD0_FEE node a second CU type was defined.

The FSM state diagram for the AD0 DCS top node is shown in Fig. 7. The possible transitions between states are represented by arrows. The actions and "nonoperational" states are shown on the right. This implementation of AD0 control hierarchy is based on the guidelines provided by the ALICE Controls Coordination (ACC) [13].

B. DCS Main User Interface

The framework FSM component allows associating the custom user interfaces (panels) with any DU or CU in the hierarchy. Commands can be sent, and states can be shown graphically from these interfaces. The user can also navigate through the hierarchy and display the operation panel for each node. The user interface of the AD0 DCS top node is shown in Fig. 8.

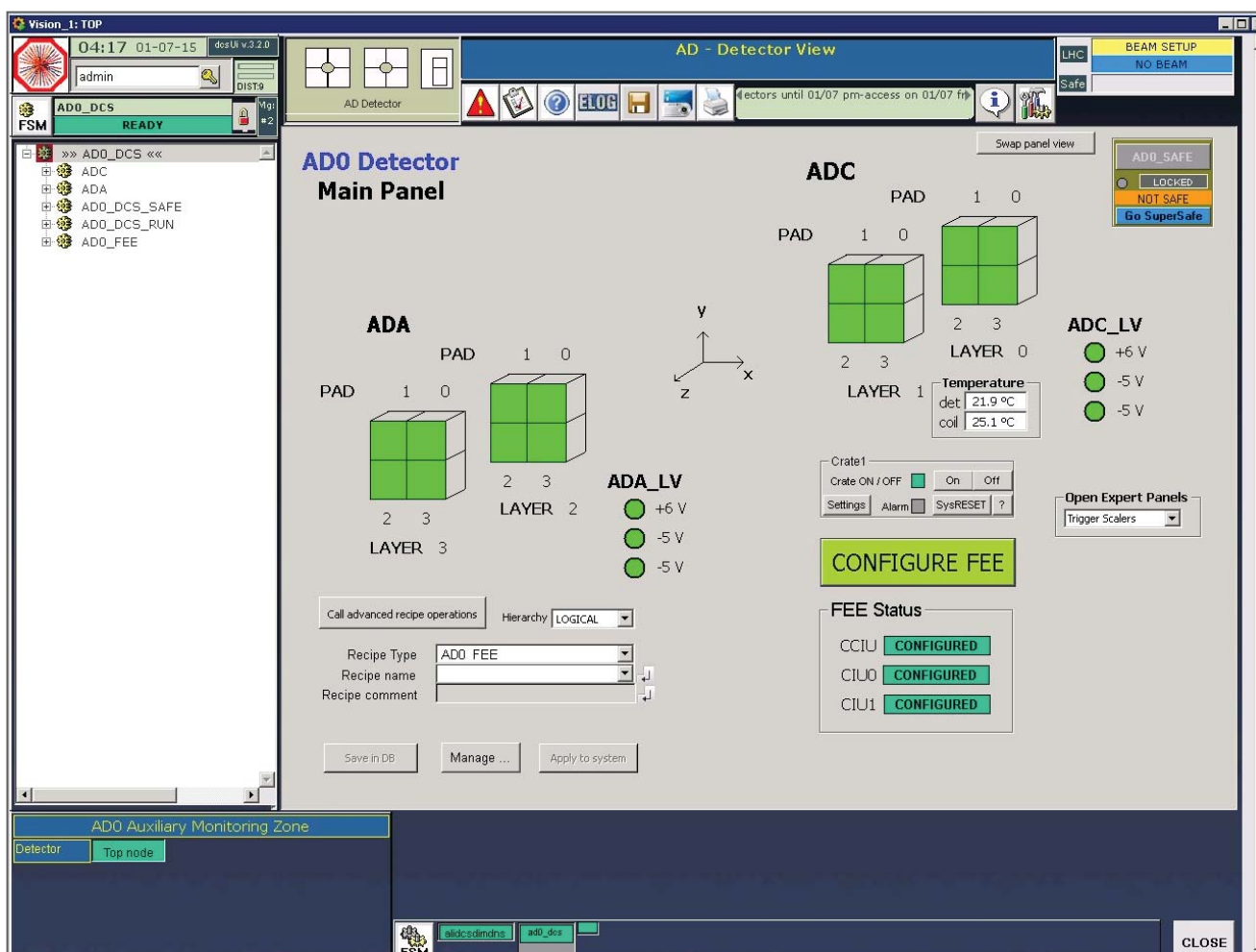

Fig. 8 AD0 DCS main user interface. The current status of all the detector equipment can be monitored and the configuration of the FEE can be sent from this panel

C. ADC and ADA Nodes

ADC and ADA CUs control the high and low voltages in the ADC and ADA sub-systems, respectively. As it was

already mentioned, these control units are of the same type and therefore they share the same FSM state diagram. Fig. 9 shows the state diagram, the states/actions of the ADC and ADA nodes.

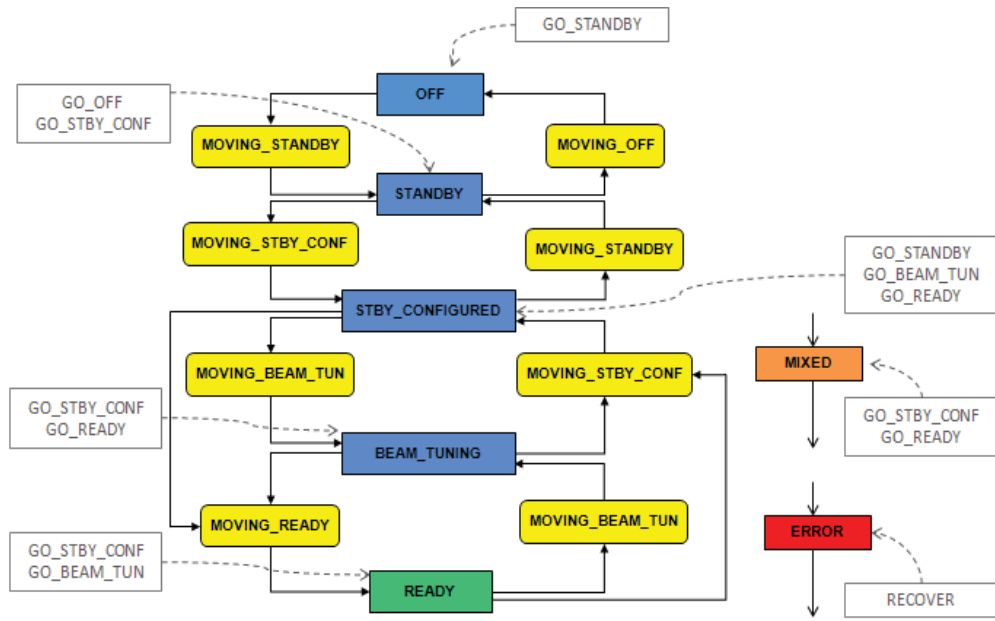

Fig. 9 FSM state diagram of the ADC and ADA control units

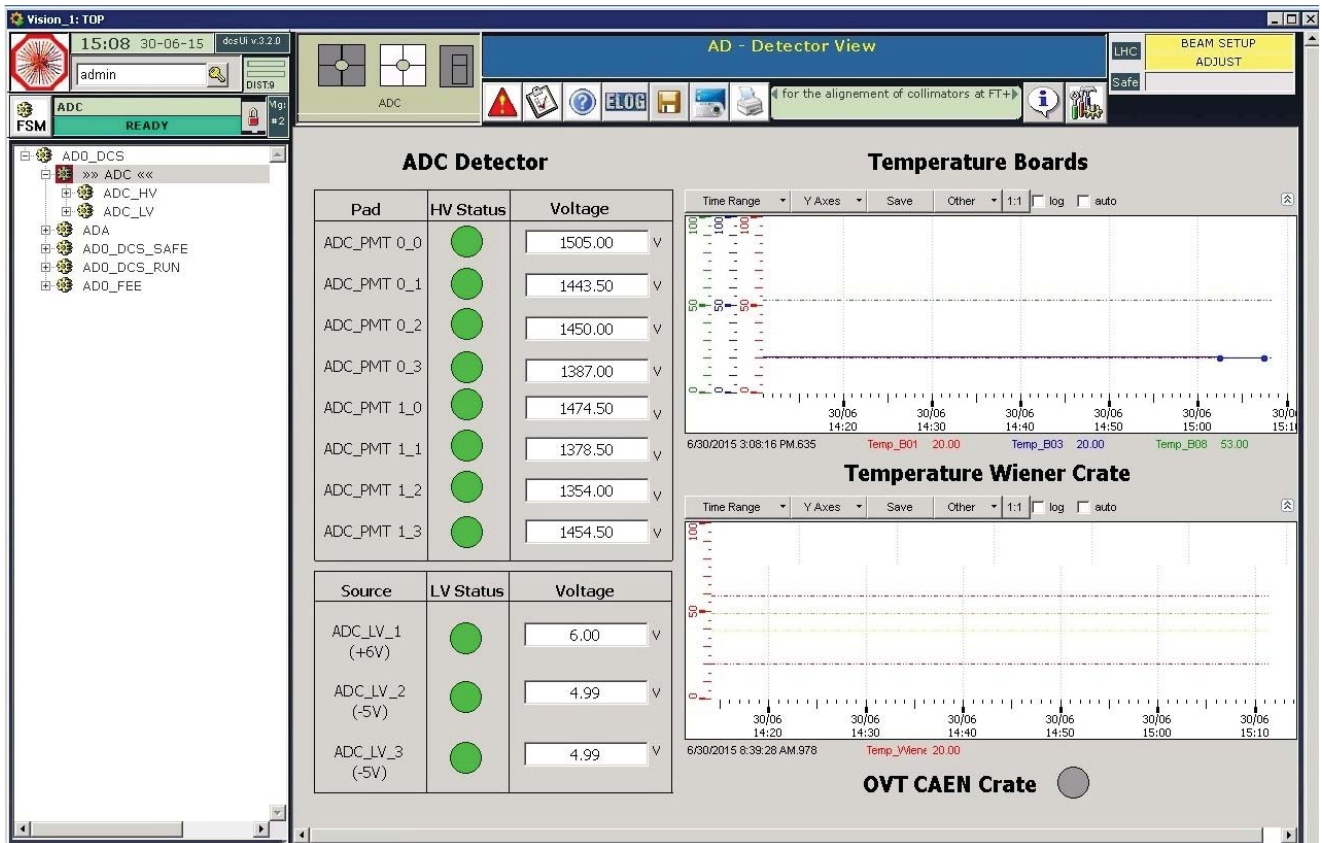

Fig. 10 ADC node user interface

Fig. 10 shows the user interface for the ADC control unit. In this panel, the status and the output voltage value for all the high and low voltage channels are monitored. The panel also displays the temperature trending graphs for the high and low voltage cards and for the VME crate housing the FEE cards. An indicator lights at the bottom of the panel when an

overvoltage condition on the SY1527 power supply crate appears. This same interface is used for the ADA sub-detector.

D.ADC_HV, ADA_HV, ADC_LV and ADA_LV Nodes

As presented in the previous section, ADC and ADA control units have children control units to model the high and

low voltage supplies on their respective sub-detectors. ADC control unit is divided into ADC_HV and ADC_LV units while ADA control unit consists of ADA_HV and ADA_LV. These control units are also modeled as FSMs using SMI++.

Fig. 11 shows AD0 FSM tree diagram up to the third level where the position of ADA_HV/LV and ADC_HV/LV nodes in the control tree can be seen.

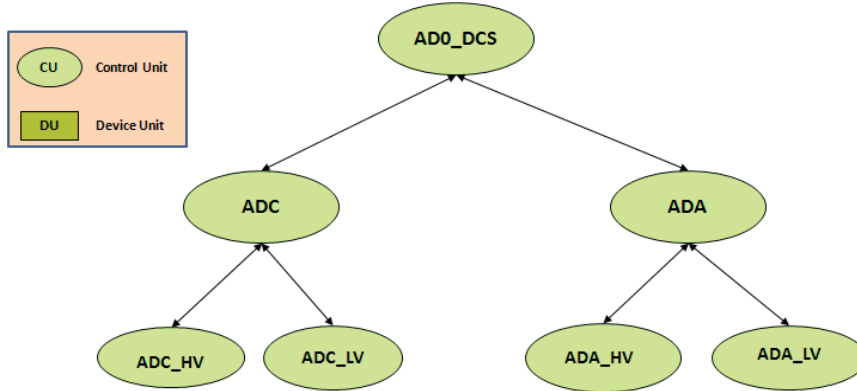

Fig. 11 FSM tree diagram of AD0 in the level 3 (ADC/ADA)

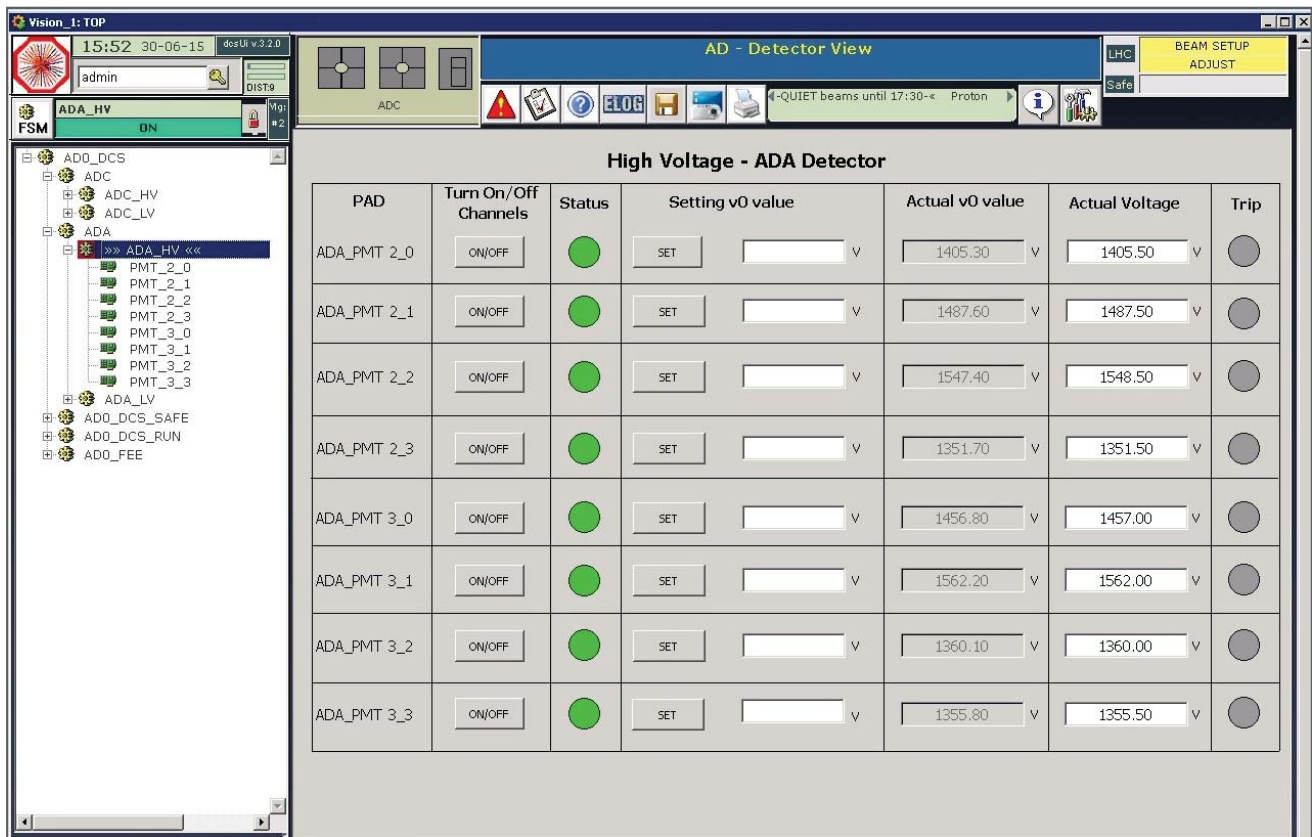

Fig. 12 User interface of ADA_HV node in the ADA domain

The state of the corresponding parent nodes (ADA and ADC) depends on the state of these CUs, and the actions sent by those parents will affect the state of them. Figs. 12 and 13 show the user interfaces to control and monitor high and low voltages, respectively, in the ADA sub-detector. The ADA_HV panel allows acting on the high voltage channels to turn them on/off and to set the output voltage level. It also monitors some of the channel parameters like the status, the

output voltage level setting, the actual output voltage, and the trip status (The trip parameter is set whenever the channel's output current equals a predefined limit value for a predefined time period). The ADA_LV panel monitors and controls some of the above parameters for the low voltage channels.

The ADC_HV and ADC_LV nodes have similar panels for their corresponding channels.

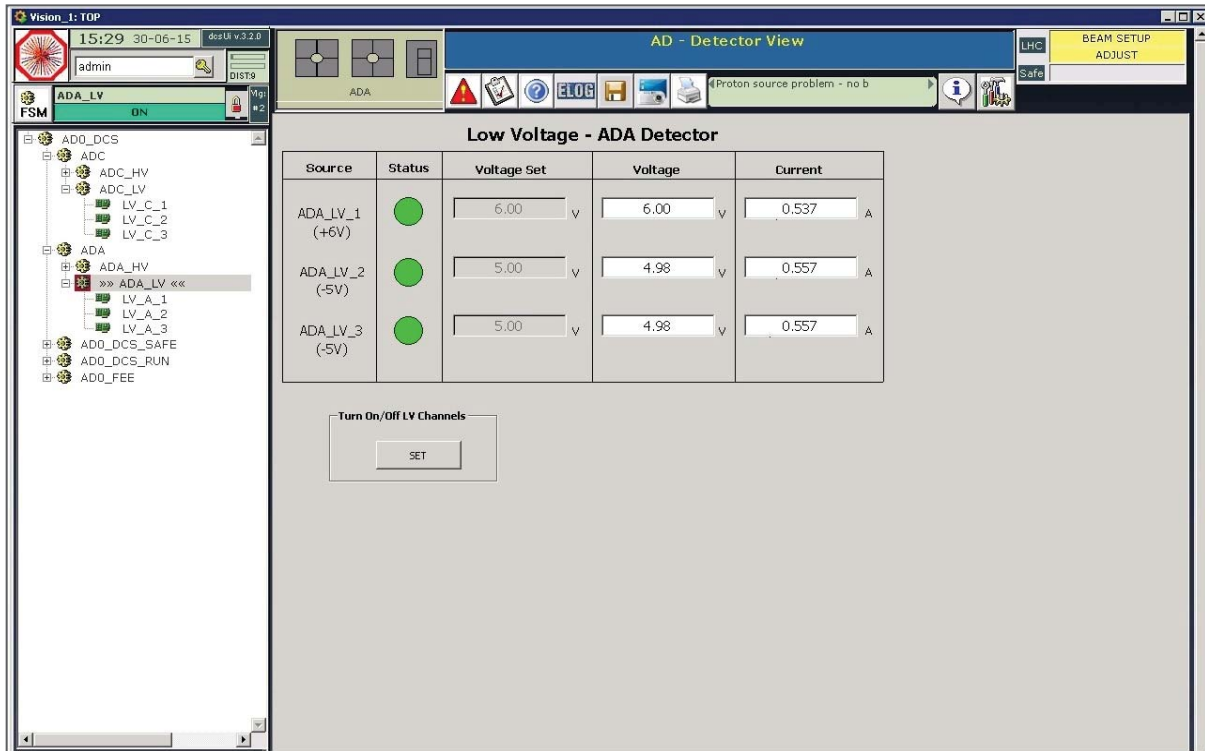

Fig. 13 User interface of ADA_LV node in the ADA domain

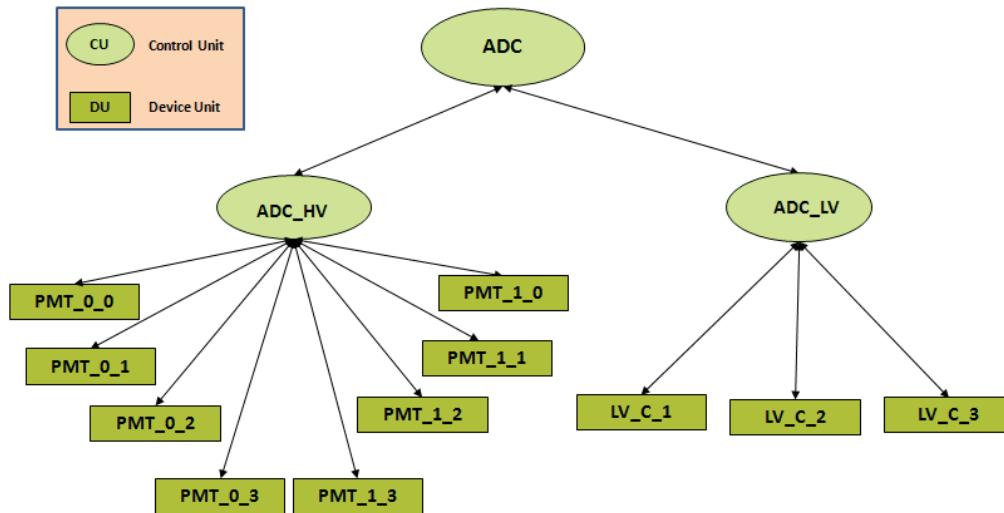

Fig. 14 FSM tree diagram in the high and low voltage in the ADC DCS

E. High and Low Voltage Channels in the ADC Sub-Detector DCS

The ADC_HV node has eight individual high voltage channels in its control domain; they feed the PMTs on the ADC layers of the detector. ADC_LV has three low voltage channels in its control domain that feed the 8 preamplifier cards for the ADC sub-detector. The FSM tree diagram showing the DUs for these high and low voltage channels of ADC sub-detector is depicted in Fig. 14.

In the high and low voltage sub-systems single channels are defined like device units since they interact directly with the

hardware channels. That means that their state no longer depends on the state of other CUs or DUs but on the real state of the channels in the AG535DP and A1513B cards. The actions issued by these DUs (received, in turn, from their corresponding parent CU) actuate on the cards' channels to change their status, voltage level, etc.

Fig. 15 shows the user interface panel for a single high voltage channel. This interface displays the values of the channel's output current and voltage and their behavior versus time.

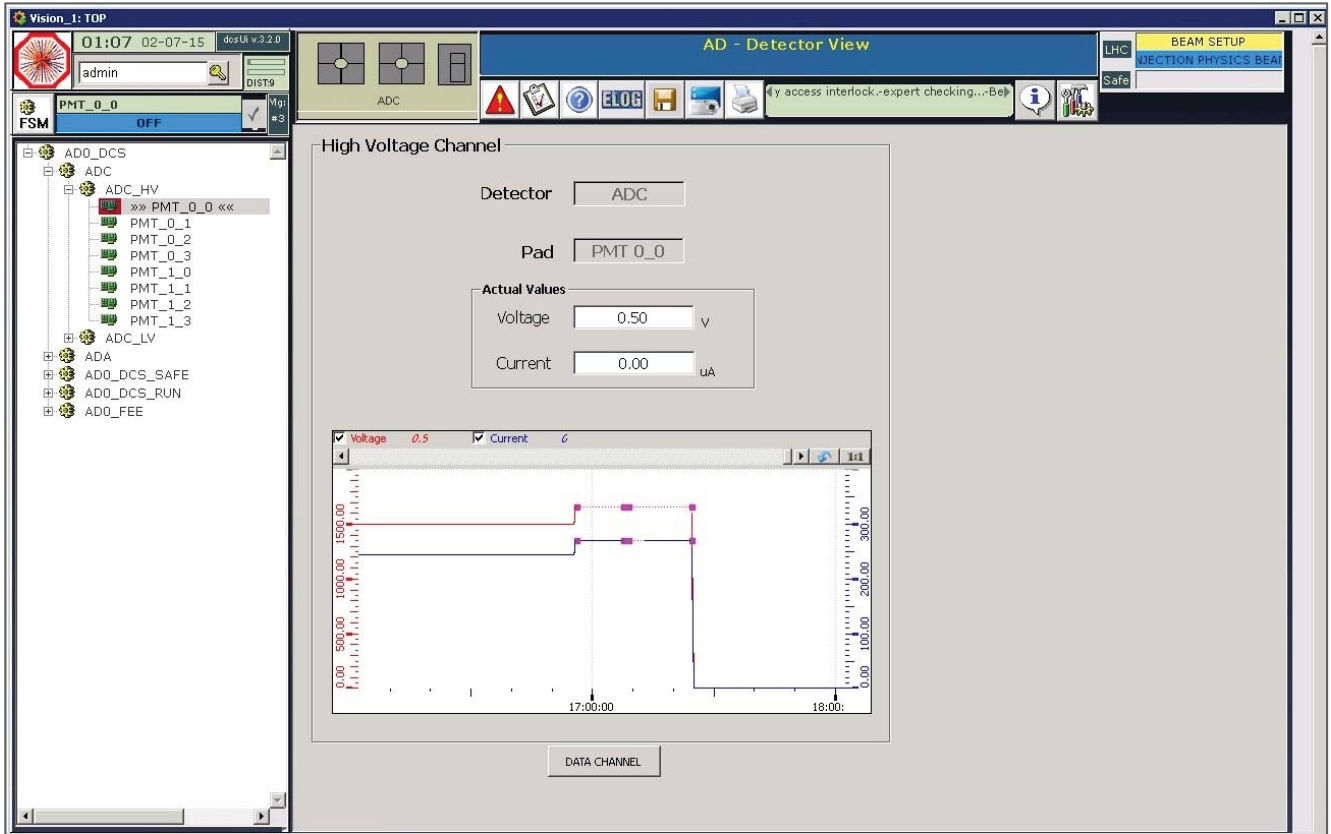

Fig. 15 User interface of a high voltage single channel in the AD0 DCS

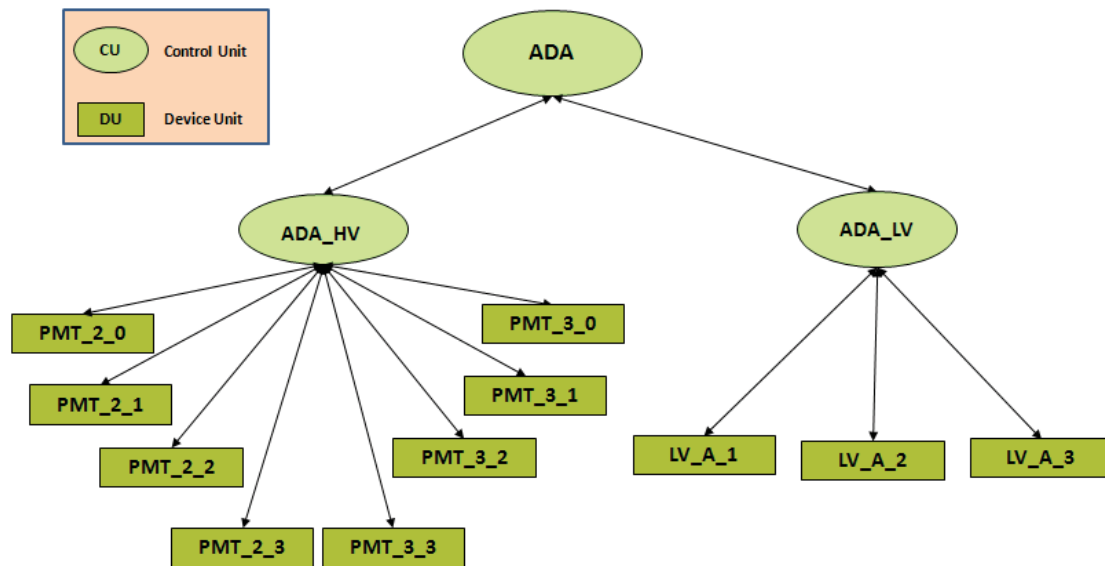

Fig. 16 FSM tree diagram of ADA DCS showing the high and low voltage channels

F. High and Low Voltage Channels in the ADA Sub-Detector DCS

Like the ADC sub-detector, ADA sub-detector has eight individual channels in the high voltage sub-system to feed the PMTs as well as three individual channels in its low voltage sub-system to feed the preamplifiers. The FSM tree diagram for the individual high and low voltage channels of the ADA

sub-detector is shown in Fig. 16.

Similar to the ADC case, the nodes in the ADA sub-tree have the same principle of operation, state diagram, user interfaces, and the same FSM control panels as the corresponding ADC nodes.

VIII. ALARMS, TRENDING, AND ARCHIVING

In this section we describe additional DCS tasks necessary for the correct, continuous, and safe operation of the AD0 detector during the data taking periods of the experiment as well as for ensuring the quality of the data. These tasks were completely tested during the commissioning of the AD0 detector control system.

The acquisition of quality data is vital to produce diffractive physics results, so the continuous and efficient operation of AD0 is of great importance. The DCS sub-systems described hereafter are the alarm generation system, the alarm help tool, the temperature trend charts (trending plots) and the running-conditions archiving system.

A. Alarms and Alarm Help in AD0 Detector

One of the key elements for a correct and safe operation of a detector in the ALICE experiment is the implementation of alarms for those parameters deemed relevant. Generation of alarms allow operators of the experiment and/or expert operators to immediately realize (and to take corrective actions) whenever a critical parameter is outside its allowed range of operation or in an undesirable state. Defining alarm

help instructions are also necessary for the central DCS operator to restore the detector to a stable and operational state in the event of a failure or disturbance. This maximizes the effective data taking time of the detector.

In the general case, the configuration of an alarm for a given parameter requires fixing one or more upper and lower limit values for the parameter assessing its levels of severity and defining the operator's help instructions.

B. Voltage and Current Alarms

PMTs are very sensitive to both high voltage and high current. Their gain can vary significantly over a small voltage interval. On the other hand, when high intensity light illuminates the photocathodes, and they draw a lot of current that can damage the PMT. So it is necessary to keep track of PMT voltage and current levels at all times and to activate alarms whenever they are too high. In the AD0 DCS, four intervals (or value bands) are actually defined symmetrically around the nominal values. The normal band and three "alarm" bands with three levels of severity: Warning, Error, and Fatal.

The configuration of these alarms and their severity levels is implemented using a WinCC script.

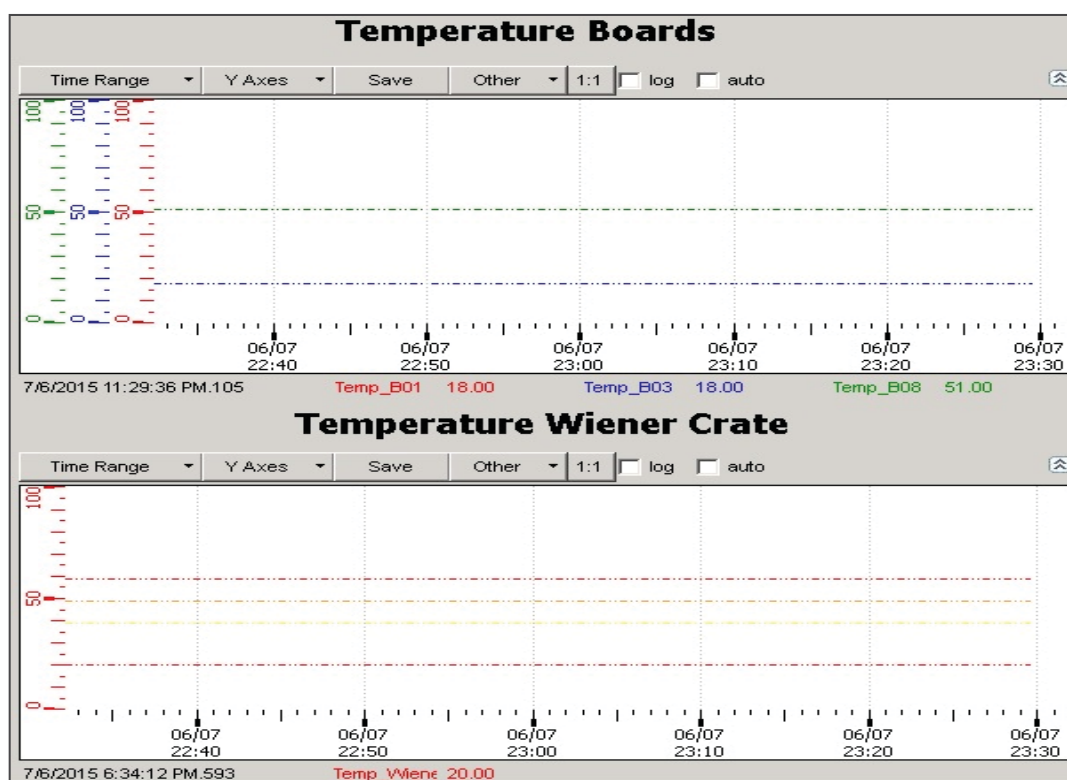

Fig. 17 Trending plots of VME crate and electronic cards AD0

C. Alarm Help

All parameters having alarm limits defined have also an associated alarm help file. This file contains a list of steps to be followed in order to correct the anomalous condition triggering the alarm to prevent damage to the equipment and, more importantly, to restore the normal data taking. There is a list of steps for each level of severity for any given alarm.

The alarms are displayed in a dedicated panel provided by Win CC showing all the alarms in a system and where the DCS or AD0 operator can acknowledge them and access to the corresponding alarm help files.

The help files are standard .xml files that can be accessed with a standard browser on operators' request.

D. Temperature Trending Plots in AD0 Detector

The temperature variations of the Wiener VME crate and the three electronic cards (CIU and CCIUs) inserted on it are monitored at all times by the AD0 detector. An alarm is also defined for this temperature. The variation in time of this temperature is presented in a trending plot in the AD0 DCS as it is shown in Fig. 17.

The transient behavior of the temperature of the high and low voltage cards is also registered and displayed in a trending plot that can be seen in Fig. 17.

E. DCS Archiving System

For proper operation of the AD0 detector and for proper analysis of the recorded data, a lot of online information has to be stored when running the experiment. The nature of these data varies widely so it is stored in a collection of databases. They are all hosted in a database server running on an Oracle Real Application Cluster (RAC) on the experiment site [14].

Two important types of data that the DCS should store are the operating conditions and the configuration of the detector. The DCS manages the data exchange through the native archive system of WinCC.

The so-called Offline Conditions Database (OCDB) stores the values that all parameters relevant for offline data analysis take when the physics data are taken. These parameters include amplifiers gain and baseline level, PMTs supply voltage, electronic boards current, detector temperature or any other parameter that could affect the physics results. These values are continuously stored during the data taking. The archive system in AD0 DCS is configured to store the PMTs supply voltages at fixed time intervals and some of the FEE configuration parameters whenever they change.

The interface between the OCDB and DCS archiving is implemented as a dedicated WinCC manager [6].

All the configuration parameters of the CIU and CIU cards (~200) are stored in the Configuration Database. There is a different set of parameter values for each type of run: cosmic, physics, or calibration runs.

IX. CONCLUSIONS

In this work, we presented a quick review of the AD0 trigger detector and the design characteristics and implementation of the AD0 detector control system. This control system was developed and successfully commissioned during the first half of 2015 for operation of AD0 in ALICE during the LHC running period known as RUN II. At the time of writing AD0 has already been triggering diffractive physics events in ALICE for about 10 months. The AD0 DCS is continuously maintained, updated, and even improved to meet ALICE global control system requirements.

ACKNOWLEDGMENTS

Authors thank all the colleagues participating in the design, construction, commissioning, and operation of the AD0 detector for their invaluable support, also the members of the ALICE Controls Coordination group for the fruitful

collaboration.

M. I. Martínez-Hernández thanks CONACyT, Mexico for the financial support through project no. CB-2011-01-166799.

The authors thank to the Mexican Network of Scientific and Technological for ALICE LHC belonging to CONACyT, Mexico.

REFERENCES

- [1] About CERN (2015). European Organization for Nuclear Research. Geneva, Switzerland. Recovered from: <http://home.web.cern.ch/>
- [2] ALICE Collaboration (2015). A Large Ion Collider Experiment. Recovered from: aliweb.cern.ch.
- [3] Villalobos, O. (2012). A Study of Diffractive Production in ALICE. Journal of Physics: Conference Series. 381 012039 doi:10.1088/1742-6596/381/1/012039.
- [4] Herrera, G. (2011). Diffractive physics in ALICE at the LHC. 5th International Workshop On High-pT Physics at LHC. AIP Conference Proceedings, Volume 1348, pp. 45-52 (2011). Recovered from: <http://indico.nucleares.unam.mx/getFile.py/access?contribId=26&resId=0&materialId=0&confId=205>
- [5] Chochula, P. et al. (2012). Operational Experiences with the ALICE Detector Control System. Proceedings of ICALPCS2013. San Francisco, CA, USA. FRCOAAB07.
- [6] Aamodt, K. et al. (2008). The ALICE experiment at the CERN LHC. Journal of Instrumentation (JINST), vol. 3, article no. S08002, doi:10.1088/1748-0221/3/08/S08002.
- [7] Company ETM (2015). (Online Website). Recovered from: www.etm.at (Consultation: June 2015).
- [8] JCOP Framework (2015) (Online Website). Recovered from: <https://wikis.web.cern.ch/wikis/display/EN/JCOP+Framework> (Consultation: July 2015).
- [9] Holme, O. et al (2005). The JCOP FRAMEWORK. 10th ICALPCS Int. Conf. on Accelerator & Large Expt. Physics Control Systems. Geneva, 10 - 14 Oct 2005. WE2.1-60.
- [10] The Standard DCS User Interface in ALICE. Ver. 3.0.7 (2008). ALICE DCS. Recovered from: http://alicedcs.web.cern.ch/alicedcs/Software/Downloads/AliceDcsUi_v3.0.pdf (Consultation: December 2015).
- [11] CAEN Company (2015). (Online Website). Recovered from: www.caen.it (Consultation: July 2015).
- [12] Zoccarato, Y., et al. (2011). Front end electronics and first results of the ALICE V0 detector. Nuclear Instruments and Methods in Physics Research Section A: Accelerators, Spectrometers, Detectors and Associated Equipment. Elsevier. Volumes 626-627, 11-21 January 2011, Pages 90-96.
- [13] Pinazza, O. READY for RUN2? Last steps and instructions for WinCC projects. DCS Workshop during the ALICE Week. CERN. March 2015.
- [14] Mercado-Pérez, Jorge (2008). Development of the control system of the ALICE Transition Radiation Detector and of a test environment for quality-assurance of its front-end electronics. PhD Thesis. CERN-THESIS-2008-141. Universität Heidelberg.