

Influence of Kinematic, Physical and Mechanical Structure Parameters on Aeroelastic GTU Shaft Vibrations in Magnetic Bearings

Evgeniia V. Mekhonoshina, Vladimir Ya. Modorskii, Vasilii Yu. Petrov

Abstract—At present, vibrations of rotors of gas transmittal unit evade sustainable forecasting. This paper describes elastic oscillation modes in resilient supports and rotor impellers modeled during computational experiments with regard to interference in the system of gas-dynamic flow and compressor rotor. Verification of aeroelastic approach was done on model problem of interaction between supersonic jet in shock tube with deformed plate. ANSYS 15.0 engineering analysis system was used as a modeling tool of numerical simulation in this paper. Finite volume method for gas dynamics and finite elements method for assessment of the strain stress state (SSS) components were used as research methods. Rotation speed and material's elasticity modulus varied during calculations, and SSS components and gas-dynamic parameters in the dynamic system of gas-dynamic flow and compressor rotor were evaluated. The analysis of time dependence demonstrated that gas-dynamic parameters near the rotor blades oscillate at 200 Hz, and SSS parameters at the upper blade edge oscillate four times higher, i.e. with blade frequency. It has been detected that vibration amplitudes correction in the test points at magnetic bearings by aeroelasticity may correspond up to 50%, and about $-\pi/4$ for phases.

Keywords—Centrifugal compressor, aeroelasticity, interdisciplinary calculation, oscillation phase displacement, vibration, nonstationarity.

I. INTRODUCTION

DEVELOPMENT of the compressor equipment is associated with the terms such increase in the pressure ratio and decrease in the material capacity and weight. The latter is particularly true for gas transmittal unit (GTU), due to the need aviation transport in region of the Far North which is difficult of access. Reduced stiffness and load growth can increase the risk of aeroelastic oscillation processes in a non-rigid thin-walled structure under the action of intense gas flows.

The foregoing allows selecting the following factors, which influence the turbomachinery equipment oscillations: imbalances arising in the manufacture and assembly of the structure; the geometry of the gas-dynamic channel; aeroelastic effects on the compressor blades and labyrinth

Evgeniia V. Mekhonoshina is with the Perm National Research Polytechnic University, Perm, Russian Federation (phone: +7-342-239-13-86; e-mail: mevpstu@gmail.com).

Vladimir Ya. Modorskii is with the Perm National Research Polytechnic University, Perm, Russian Federation (phone: +7-342-239-13-86; e-mail: modorsky@pstu.ru).

Vasilii Yu. Petrov is with the Perm National Research Polytechnic University, Perm, Russian Federation (phone: +7-342 2198430, e-mail: president@pstu.ru).

sealing; aeroelastic interaction in a dynamic system "gas-dynamic flow - a rotor with magnetic bearings".

The influence on rotor oscillations made by the technological imbalances [1], [2], and the influence on the oscillations of the blades made by processes of interaction between the flow and the impeller blades [3]-[5] are mostly studied. The rest factors are insufficiently studied [6], [7].

To study the compressors' aeroelasticity, a large scope of research activities needs to be carried out. In this paper the authors studied the differences aeroelastic vibrations in compressors from oscillation calculated in the "classical" unsteady formulation. In addition, the authors explore the characteristics aeroelastic vibrations in the gas in the blades and magnetic bearings. However, the authors examine the impact of the speed of rotation, physical and mechanical properties of materials on the parameters of aeroelastic rotor vibrations taking into account technological imbalances and magnetic bearings.

Aeroelastic calculations were carried out at model problem for verification.

II. UP-TO-DATE STUDIES' STATUS REVIEW

The history of the aeroelastic numerical calculations stems from the works related to the asymmetrical flutter that occurred during the flight of the Handley Page bomber. It was F. Lanchester who among the first researchers defined the reasons of its crush (1916) [8]. In 1918, after a breakage of the Albatros D.III biplane lower wing, Paul Richard Heinrich Blasius, the German physicist, carried out one of the first flutter analytical calculations. The first numerical calculation of the aerodynamic force affecting a thin plate harmonically oscillating in a two-dimensional flow was carried out later in 1922 by W. Birnbaum in his thesis research, which was written at Goettingen University [9], [10]. In the 1920s, theoretical physicists W. Birnbaum, H. Wagner, H. G. Küssner developed a flutter mathematical model being an ordinary differential system. The first precise solution of the flutter problem was obtained by T. Theodorsen in 1934. In Russia, the studies of the flutter phenomenon started later in 1930. A pioneer in this area was E. P. Grossman [8].

Many researchers studied the aeroelasticity problem. In 1972, A. S. Volmir described forced oscillation of a plate undergoing the effect of an alternate shearing load [11]. In paper [12] the problem of aerohydroelasticity was considered in details. The authors considered the range of tasks where the influence made by the environment on the structure behavior

needed to be taken into consideration. It was noted that the range of such tasks continuously widens [12]. The authors take a gas-elastic approach to calculate vibration modes in power installations, give physical and mathematical models of a process, and suggest a unified algorithm and solution method [13]. Large number of model tasks' solutions is quoted.

When solving the task of coupled oscillations of a solid object and gas flow numerically, researchers encounter a number of difficulties. Firstly, multidisciplinary of the task: to solve it, methods of theory of elasticity, aerodynamics and theory of oscillations are to be used. Secondly, nonstationarity of the progressing processes. Thirdly, difficulties of mathematical character occur when solving coupled problems, which is caused by physical inhomogeneity of the gas-structure system and absence of the unified mathematical apparatus to describe its behavior within the framework of simultaneous equations [14]. Fourthly, solving of the aeroelasticity tasks is a computationally and resource intensive process and requires certain knowledge in the area of supercomputer technologies, including parallel computations.

Due to existing difficulties, the problem of oscillations is studied either from the point of gas dynamic, or of the theory of elasticity. For example, in the papers [15]-[17] the studies of gas dynamics in the centrifugal compressors are presented. In addition, in the paper [18] a suggestion that the compressor blade's oscillatory mode and frequency are independent on the airflow was made. This paper concerns flow oscillations around an oscillating blade of the jet engine compressor. Nonetheless, there are some papers, which describe the associated statement implementation. Researchers from the USA [19] carried out an overview of associated numerical schemes. They applied one of approaches to the flutter

research problem [19]. Vibration phenomenon of the wind driven turbine blades was jointly studied by researchers [20] from three countries: China, Australia and the USA. The authors carried out their numerical calculations in ANSYS application software product, with due consideration of interaction between the gas flow and the structure. The scientists noted that the effect caused by the abovementioned interaction is significant and shall not be disregarded [20]. In paper [21], the description of aeroelastic calculations of a turbine blade in the gas flow is given. This approach demonstrated that estimated blade capacity significantly differs due to consideration of the aeroelastic deformations.

III. VERIFICATION OF THE NUMERICAL AEROELASTIC CALCULATIONS

A. Physical Model

With a view to verify the methodology of carrying out the coupled calculation in ANSYS, a testing task of modeling the interaction of a supersonic gas-dynamic flow with a deformed plate in the 3.75 m long shock tube (Fig. 1). [22], [23] was considered.

It must be noted that the workflow is generated due to nonstationary expansion of air from the high-pressure chamber. Membrane rupture during the installation start ensures formation of the expanding detached shock wave. In the computational experiment, the flow is the perfect gas. The installation consists of two areas: HPA (High Pressure Area) and LPA (Low Pressure Area). The deformed plate is an elastic homogenous body made of steel (density $\rho=7,600$ kg/m³ and Young's modulus $E=220$ GPa). The plate is installed on the nondeformed foundation.

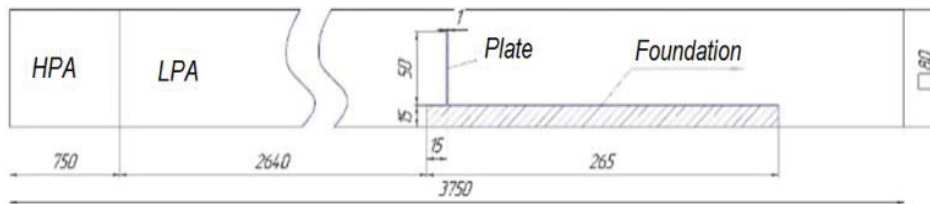

Fig. 1 Experimental installation scheme [22], [23]

The following system of assumptions for development of the calculation model was accepted:

1. Friction on the sidewalls is not be taken into account in calculations. To decrease the calculation time, in direction of the Z-axis the dimension corresponding to two computational cells is accepted.
2. To decrease the calculation time, the distance between the entrance and the butt-end of the deformed plate is reduced.
3. Deformations of the foundation are not taken into account in evaluating calculation of the stress strain behavior components.
4. The k-ε turbulence model is used.
5. The process of the membrane rupture is modeled by an

instantaneous membrane disappearance.

B. Realization in ANSYS

Thereat, the following 2FSI (two-way Fluid Structure Interaction) bilateral calculation scheme is realized in ANSYS (Fig. 2) [20]. The solution is found by means of an iterative method. Two problem solvers: Transient Structural (non-stationary mechanics, finite element method) and CFX Transient (gas dynamics, finite volume method) are joined together by the data transfer. The obtained gas-dynamic flow parameters are the initial data for calculation of the boundary conditions of the task aimed at evaluation of the structure stress strain behavior (SSS). Thereat, the 2FSI problem solvers get prepared in two stages:

Stage 1: Preparation of the plate submodel in the SSS Transient Structural problem solver;

Stage 2: Preparation of submodel of the gas-dynamic channel in the CFX Transient problem solver.

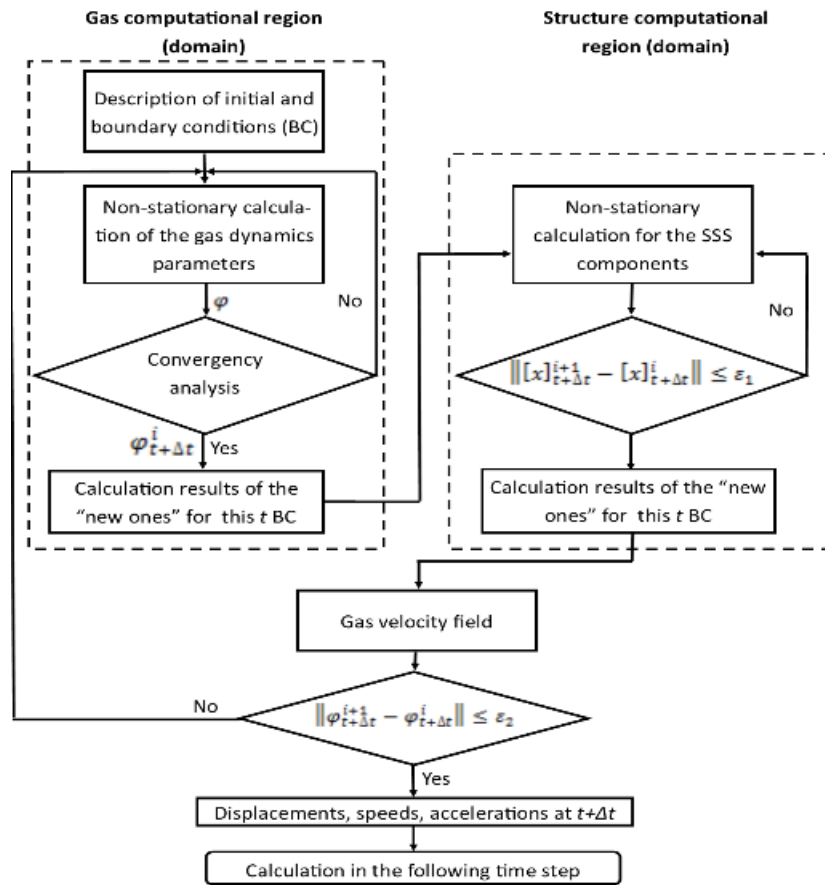

Fig. 2 Block diagram of the 2FSI algorithm in ANSYS

C. Mathematical Model

In accordance with the selected physical model, mathematical model, which includes two submodels, is used. The gas-dynamics submodel is based on the mass, impulse, and energy conservation laws, equation of perfect compressible gas state, and is closed by the initial and border conditions. The mathematical submodel for SSS evaluation is recorded as follows [24], [25]:

$$m\ddot{x} + c\dot{x} + kx = F(t). \quad (1)$$

where m is the mass matrix; c is damping matrix; k is rigidity matrix; $F(t)$ is the load vector; x means displacements.

At any specific time, these equations can be considered as a set of static equilibrium equations, where the forces of inertia and damping are also taken into account. To solve these equations, Newmark time integration method [24], [25] is used. The increment between sequential instants of time, integration steps, etc., are calculated. The mathematical model is closed by the initial and border conditions.

D. Initial Conditions

Initial conditions for the associated statement are the stress-

free state of the structure and the undisturbed gas.

E. Boundary Conditions of the Structure's Submodel in the SSS Transient Structural Problem Solver

Boundary conditions for the structure are presented in Fig. 3. The plate is fastened with its bottom butt-end (i.2). Three faces of the plate interact with the gas flow (i.3). The flow moves in the direction of the OX axis.

F. Boundary Conditions of the Gas-dynamic Submodel in the CFX Transient Problem Solver

Boundary conditions for gas dynamics are presented in Fig. 4. It is accepted that the calculation model consists of two areas: HPA and LPA, and in each of them, the gas is motionless in the initial instant of time. The pressure drop was accepted equaling 0.254 MPa.

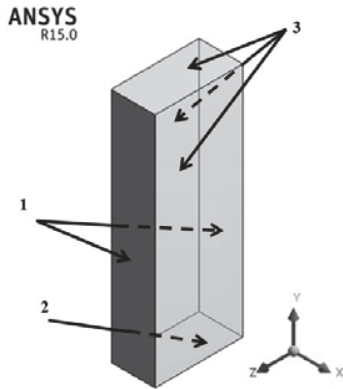

Fig. 3 Calculation model for evaluation of the plate SSS components: 1 – blockage of normal displacement; 2 – anchorage; 3 – “structure–gas” interface

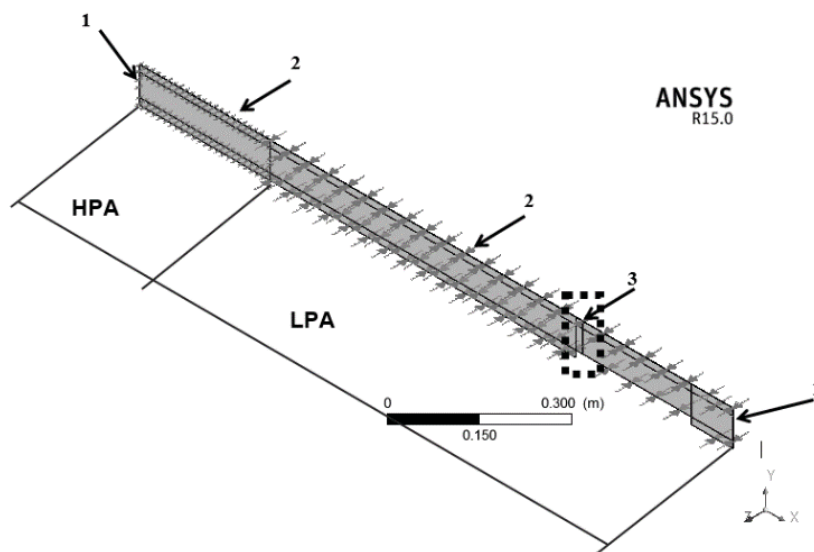
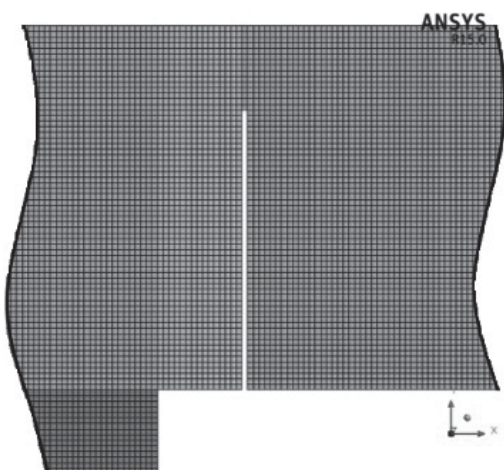
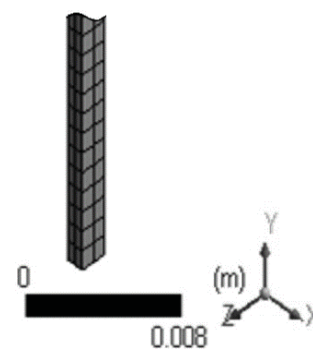

Fig. 4 Calculation model for gas dynamics: 1 – wall; 2 – symmetry; 3 – “gas–structure” interface



(a)



(b)

Fig. 5 Fragments of the gridded model: (a) gas-dynamic channel; (b) structure

G. Boundary Conditions of the Gas-dynamic Submodel in the CFX Transient Problem Solver

To solve the initial partial differential system, the submodels were split to cells. The fragments of the gridded models are presented in Fig. 5.

H. Verification

The results of the computational experiments (CE) done by the authors and the results [22], [23] that were taken as standards are shown in Fig. 6. The instant of time was taken about zero when interaction between the plate and the incident normal shock wave result in the plane shock wave moving against the flow. The positive values on the charts correspond to the edge displacement against the flow [22], [23].

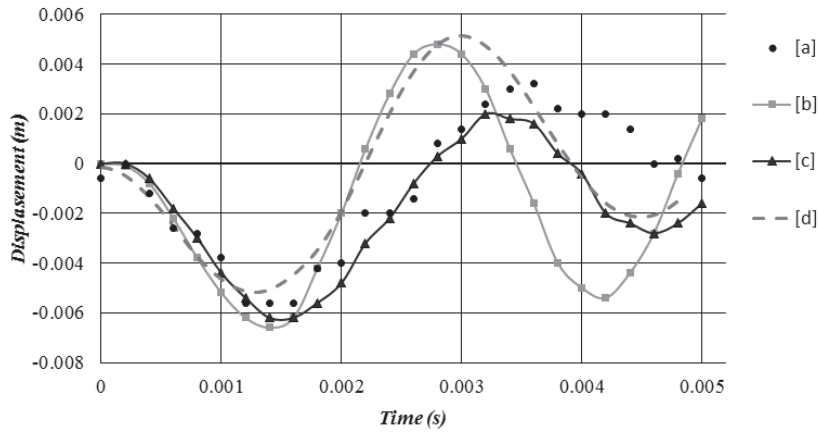

Fig. 6 Time dependence of the plate edge displacement: (a) experiment [23], (b) CE [23], (c) CE [22], (d) CE

IV. AEROELASTIC CALCULATION OF THE GTU CENTRIFUGAL COMPRESSOR

A. Physical Model

The given aeroelastic calculation method was applied for the modeling in the system of gas-dynamic flow and magnetic suspension rotor by the example of the centrifugal compressor experimental stage. Its geometry is constructed by means of Vista CCD builder (centrifugal compressor design).

The rotor, which rotates with a uniform angular velocity, is considered in the gas-dynamic submodel. The rotor in assembly, including its shaft, impeller and magnetic bearings (MB1 (magnetic bearing) near free rotor end, MB2 near transmission), is considered in the calculation of the SSS components evaluation. Eccentricities of the shaft areas are logged. Calculations were carried out with due consideration of gravitation. Interference of the gas-dynamic flow and deformed rotor is logged.

The ratio of the shroud to the hub equals 4.4; impeller width is 134 mm. On the impeller, eight blades are installed; their thickness is 4 mm. The rotor is 2 m long, the width of a magnetic bearing equals 200 mm, the structure material is steel, the walls are rough-surfaced, and their eccentricity equals 10 μm . The rotor speed equals 6,000 rpm. The flow of the non-reacting perfect gas is considered; the flow is monophasic. The pressure ratio is 1.3; the inlet pressure equals 0.1 MPa, mass flow rate equals 1.8 kg/s.

B. Boundary Conditions of Rotor Submodel in the SSS Transient Structural Solver

In Fig. 7, the boundary conditions for the structure are presented.

C. Modeling of Eccentricity

Since the non-coaxial values of various shaft areas does not exceed dozens of micrometers, the direct numerical modeling requires splitting the grid in the areas of these displacements to dimensions of a cell which is 5 to 10 times smaller than the non-coaxial value. Thereat, even with due consideration of the adaptation, the grid model contains several dozens of millions of cells. This, in its turn, requires the usage of expensive highly productive computer systems and significantly

increases calculation time. Mostly, this problem is unachievable for user engineers.

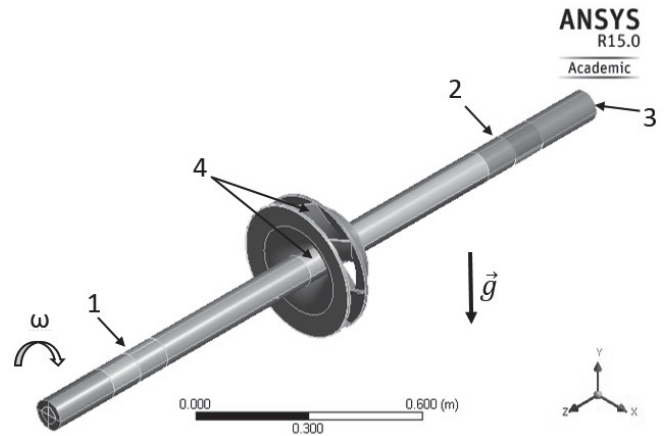
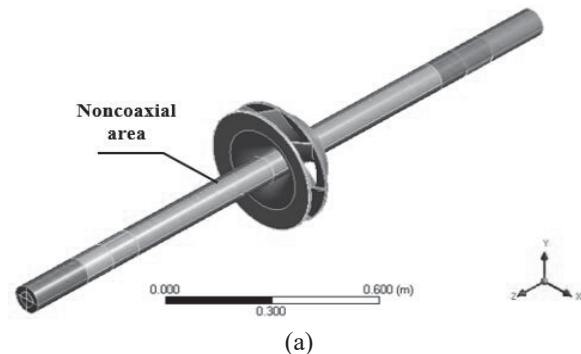

Fig. 7 Calculation scheme for evaluation of compressor SSS components: 1 and 2 correspond to MP1 and MP2 magnetic bearings, accordingly; 3 – normal displacements blockage to the surface; 4 – “structure–gas” interface

There was suggested a possibility to overcome the above mentioned computational problem in the course of numerical modeling. It is suggested to use a load on the surface of a shaft in order to simulate imbalance occurring in this section (Fig. 8). Thus, it becomes possible to reduce the timing and computing resources required.



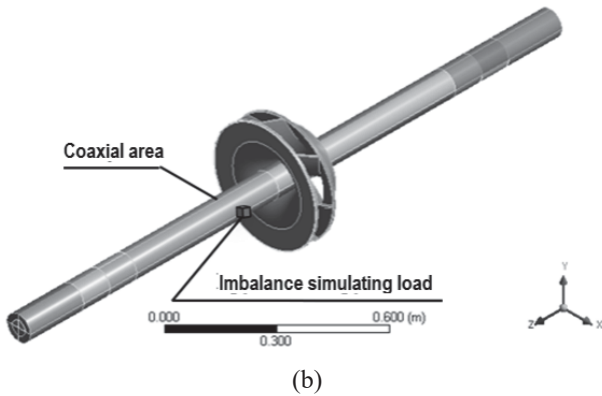

Fig. 8 Modeling of compressor rotor eccentricity: a – in an evident manner; b – by means of a corrective load

D. Boundary Conditions of Gas-Dynamic Channel Submodel in the CFX Transient Solver

A 3D computational submodel of gas dynamics is presented in Fig. 9.

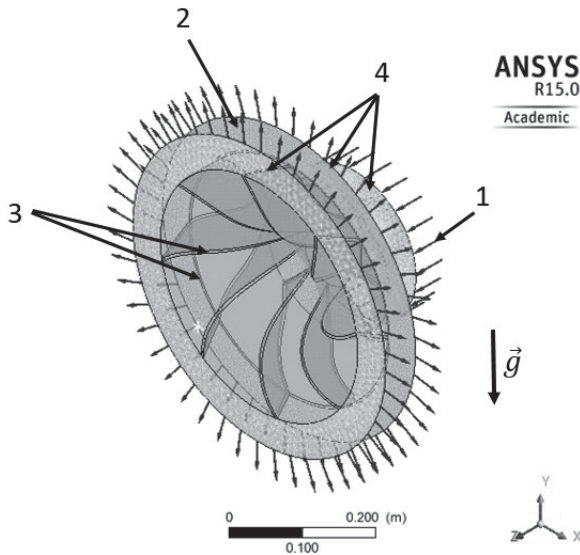

Fig. 9 Calculation scheme of compressor gas dynamics: 1 – inlet; 2 – outlet; 3 – “gas–structure” interface (realized on the blade surfaces, top discs and the hub); 4 – moving grid on the surfaces of the hub and shroud

E. Gridded Models

Then, solid and gridded models of the structure and gas-dynamic part were developed. In Figs. 10 and 11, fragments of gridded models are presented. Gridded models were developed by means of using the Ansys Meshing grid builder.

The gridded model for evaluation of the SSS components includes about 75,000 elements, and 1,666,000 elements for calculation of gas dynamics.

F. Carrying out of Computational Experiments

Calculations were carried out in the ANSYS 15.0 computer engineering analysis system with usage of the computing capacities of the high performance computer complex of Perm National Research Polytechnic University. The average

duration of calculation comprised 2.5 days using 16 IntelXeon E5-2680 processor cores. Memory space required for the results storage shall be at least 90 GB.

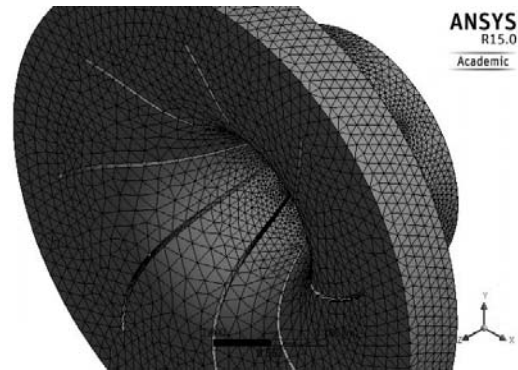

Fig. 10 Fragment of the gridded model of gas-dynamic channel

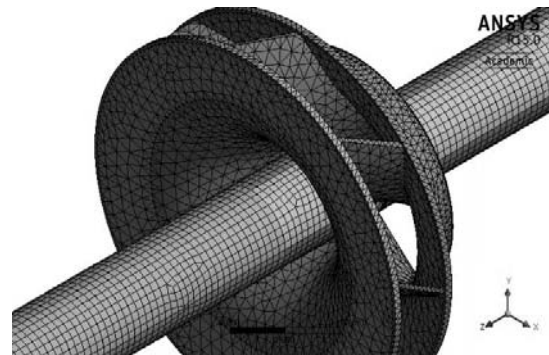

Fig. 11 Fragment of the gridded model of rotor structure

V. RESULTS OF AEROELASTIC CALCULATIONS OF THE GTU CENTRIFUGAL COMPRESSOR

In the course of calculations, rotation speed and the modulus of the structure material elasticity were being varied. At that, the SSS components and gas-dynamic parameters in the system of gas-dynamic flow and magnetic suspension rotor were evaluated.

Time dependences of the gas-dynamic parameters and stress strain behavior components obtained in the course of the computational experiments were calculated within the same time periods. As a matter of analysis convenience, the charts were located under each other. In each chart the results of the 2FSI calculation and either the nonstationary SSS, or the nonstationary gas dynamics calculations were represented. The average displacements value was located between the first maximum and minimum values. The oscillations amplitude values were evaluated as the difference of displacements in the first maximum and the average value. To define the oscillation periods, the time interval between the first two maximums was selected.

A. Preliminary Analysis

A preliminary analysis demonstrated that the “rotor” frequency equals 100 Hz, the “blade” frequency equals 800 Hz, and the critical one is about 111 Hz. The critical frequency was defined by means of the Campbell diagram with the usage

of the tools of Modal ANSYS module which does not take into account the influence made by the gas. The obtained

result is presented in Fig.12, where the critical rotation speeds are marked with triangles.

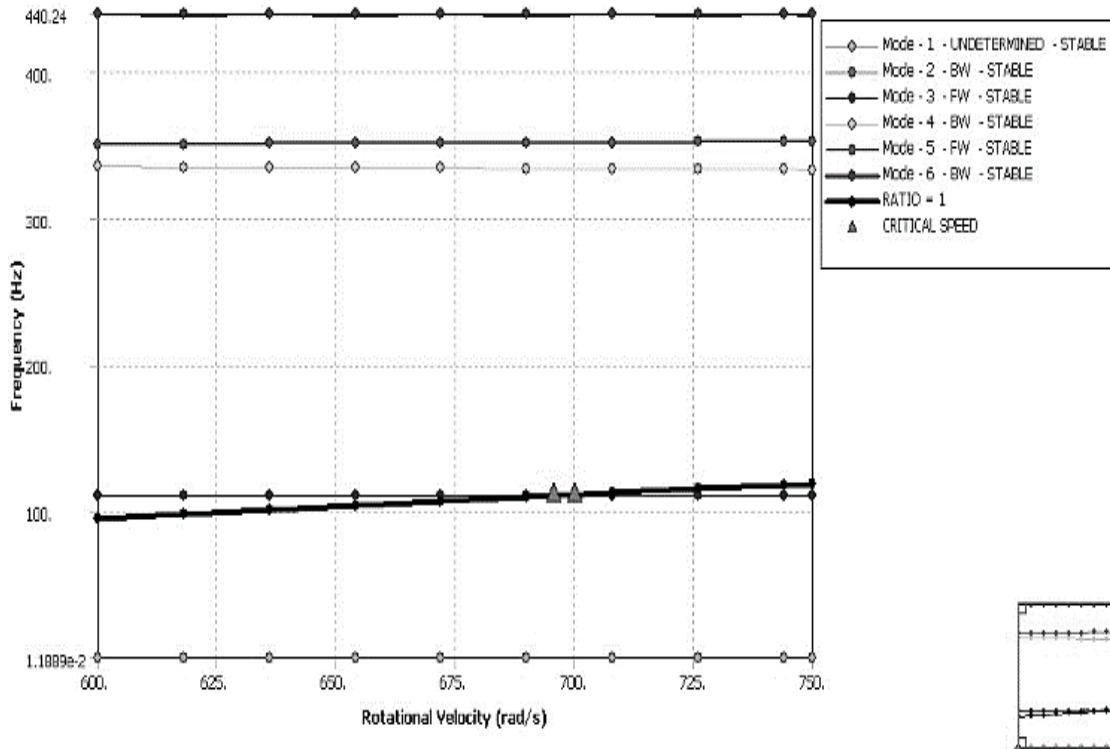
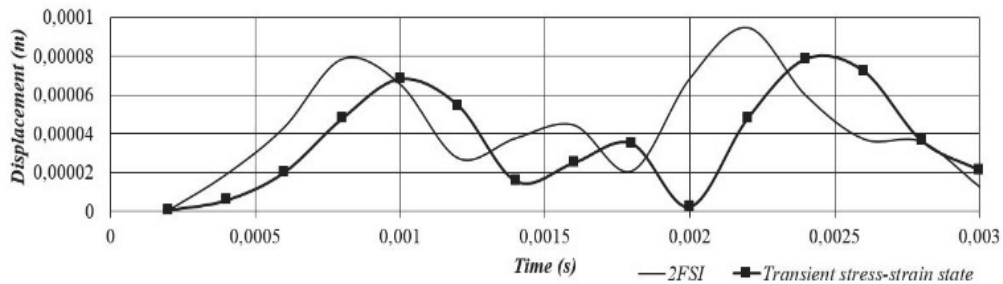

Fig. 12 Campbell diagram

The basic calculation time dependences analysis (Fig. 13) demonstrated that oscillations of the gas-dynamic parameters in vicinity of a rotor blade occur with the frequency of about 200 Hz, and oscillations of the SSS parameters on the upper

blade edge occur with the frequency of approximately four times higher, i.e. with almost “blade” frequency. In Table I computing experiment results are quoted.



(a)

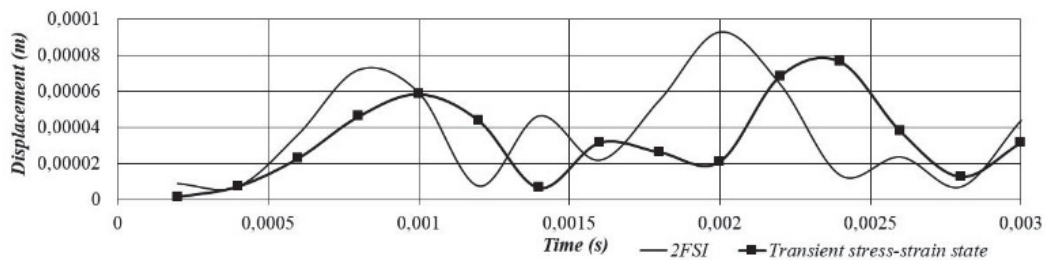

(b)

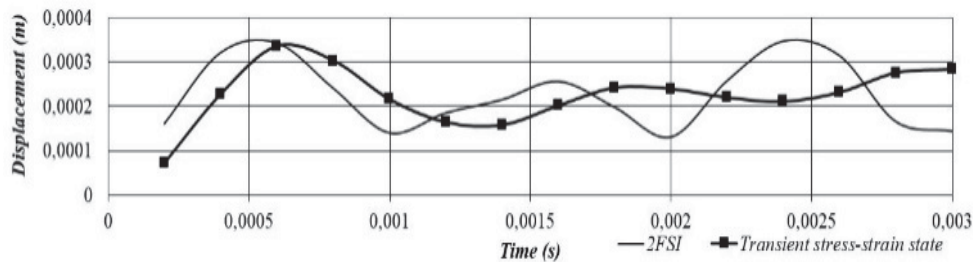

(c)

Fig. 13 Time dependences obtained for the basic calculation: a – displacements in the test point corresponding to MP1; b – displacements in the test point corresponding to MP2; c – displacements in the test point on the blade; d – full pressure in the point above the blade

TABLE I
 COMPUTATIONAL EXPERIMENT RESULTS

Area	1 Gas oscillations frequency, Hz	2 Structure oscillations frequency, Hz	3 Oscillation amplitude of structure, μm	4 Displacement s' nominal values, μm	5 Oscillation frequency, Hz	6 Maximum displacements' difference, μm	7 Minimum displacements' difference, μm	8 Amplitude difference, μm
Basic calculation								
MP1	-	726	25,5	53,1	685	10.33	11.8	-0.779
MP2	-	1,754	32,2	39.56	1,649	13.3	0.857	6.22
Blade	227.58	909	101	241.5	824	8.18	-17.8	13
Rotation speed, $\omega=4000$ rpm								
MP1	-	909	5.22	25.7	492	11.3	19.2	-3.94
MP2	-	1,090.5	3.34	24.5	600	11.5	19.3	-3.88
Blade	189.39	946.97	18.9	25.5	537	-29.7	-6.9	-11.4
Material's elasticity modulus, $E=9 \times 10^{10}$ Pa								
MP1	-	1,032.3	29.3	174.5	1,000	4.82	96.3	-45.8
MP2	-	1,084.6	36	125.5	1,084.6	16.5	65	-24.3
Blade	228.57	653.59	171	560	621.36	-16	40.3	-28.2

Columns 1, 2, 3, 4 – gas flow is considered; Column 5 – gas flow is not considered; Column 6, 7, 8 – comparison of the 2FSI calculation and the nonstationary SSS.

B. Analysis of the Influence Made by the Modulus of Structure's Material Elasticity

It can be seen from Table I that with the tenfold increasing of the elasticity modulus, the pressure oscillation amplitude (in the aeroelastic statement) drops about two times, from 4.92×10^3 m to 2.79×10^3 m. Increase in the modulus of the structure's material elasticity results in the rise of displacement oscillations' frequencies, namely, 1.4 times in the test point on the blade (Table I) and 1.6 times in the test point on MP2 (Table I). Displacement oscillations frequency in the test point on MP1 decreases 1.4 times (Table I).

When having increased the modulus of material elasticity, the displacement amplitude oscillation in the test points at MP1 and MP2 decreased insignificantly, by $3.8 \mu\text{m}$. At that, the average displacement values decreased three times. Despite the significant decrease of the average displacement values at the abovementioned modulus of the structure's material elasticity, oscillation amplitude changes insignificantly.

C. Analysis of the Rotor Rotation Speed

The analysis of the influence made by the rotation speed on the oscillations revealed that its increase results in the rise of frequency and amplitude of the aeroelastic pressure oscillations. The 50% rotation speed growth can cause the

displacement oscillation frequency in the test point on MP2 (by 60%), and its decrease in the test point on MP1 (by 20%) and in the test point on the blade (by 4%). At that, the displacement oscillation amplitude increases in all test points.

D. Comparison of the 2FSI Calculation and Nonstationary SSS

In the 2FSI statement, related to elastic nonstationary SSS, an initial shift of the aeroelastic oscillations is observed. In the baseline scenario, it equaled $(-\pi/4)$ in the test point on MP1 (Fig. 13 (a)). Oscillations' amplitudes in the 2FSI statement are higher than in the nonstationary SSS; for the test point in MP1 in the basic calculation this value equaled $10 \mu\text{m}$. The values for the other test points and calculations are presented in Table I.

Along with that, oscillations' modulations caused by the oscillatory process running on with "rotor" frequency are observed both in the gas and in the structure.

VI. CONCLUSION

Differences between the aeroelastic oscillations and those calculated in the "classical" nonstationary statement both by the amplitude (up to $45 \mu\text{m}$), and the initial phase (being $-\pi/4$ for the baseline scenario) are observed. At the low rotation speeds, the frequency difference up to two times was revealed.

The difference between the oscillations' frequencies in the gas in vicinity of the blade (equaling 227.6 Hz for the baseline scenario) and the oscillations' frequencies in the blade (equaling 909 Hz for the baseline scenario) is observed in the test point on MP1 (726 Hz), and in the test point on MP2 (1,754 Hz).

The effect made by the interaction in the system of gas-dynamic flow and magnetic suspension rotor is more visible at low values of the material elasticity modulus.

Change in the rotor rotation speed causes the oscillation frequencies redistribution in the magnetic bearings and on the blades.

To carry out the regimes analysis both in the area of critical frequencies and in working regimes, the aeroelastic processes shall be metered.

With the rotation speed increase in the aeroelastic statement, regimes both with decrease of the oscillations' characteristic frequency in MP1 and on the blade, and with decrease in MP2 were revealed.

It was revealed that with the increase of the structure material's elasticity modulus, oscillations frequencies decreased in one support and increased in another one.

ACKNOWLEDGMENT

The research is financed by the grant of the Russian scientific fund (project No. 14-19-00877).

REFERENCES

- [1] V.F. Makarov, S. Beloborodov, A.Y. Kovalev, Application of methods adaptive balancing and assembly to ensure the dynamic stability of the rotors of gas-transmittal units (In Russian). Compressor equipment and pneumatics, no. 6, pp. 37-40. 2010. (Применение методов адаптивной балансировки и сборки для обеспечения динамической устойчивости роторов газотурбинных агрегатов).
- [2] V.F. Makarov, S. Beloborodov, A.Y. Kovalev, Technological support vibration protection of shafting elements (In Russian). Compressor equipment and pneumatics, no. 3, pp. 14-17. 2011. (Технологическое обеспечение виброзащиты элементов валопровода).
- [3] V.E. Saren, Aeroelastic vibrations blade row axial turbomachine (In Russian). Problems of mechanical engineering and reliability of machines, no. 1, pp. 21-27. 2010. (Аэроупругие колебания лопаточного венца осевой турбомашин).
- [4] G.S. Pisarenko, Aeroelasticity of turbomachinery (In Russian). Ed by GS Pisarenko. Kiev: Naukova Dumka, 1980. (Аэроупругость турбомашин)
- [5] G.S. Samoylovich. Unsteady flow and aeroelastic vibrations of turbomachinery lattices (In Russian). Ed by GS Samoylovich. Moscow: Nauka Publisher, 1969. (Нестационарное обтекание и аэроупругие колебания решеток турбомашин).
- [6] E. V. Mekhonoshina, V.Ya. Modorskiy, On a phase-shift of waves at the medium interface, (In Russian). Computer Optics, vol. 39, no. 3, pp. 385-391. 2015.
- [7] V. Y. Modorskiy, A. F. Shmakov, Numerical Modeling of Gas-dynamic Processes and Processes of Deformation in Compressor of Model Test Bench of the Gas-Distributing Unit, Applied Mechanics and Materials, Vols. 799-800, pp. 865-869, Oct. 2015.
- [8] S.K. Betyaev, On the history of fluid dynamics: Russian scientific schools in the 20th century, Moscow: Physics-Uspekh, vol. 173, no. 4, pp. 419-446. 2003.
- [9] T. P. Arsentiev, The Abstract of the thesis Fluctuations of a wing in a supersonic stream of gas (In Russian): PhD thesis abstract physical and mathematical science. St. Petersburg State. University, St. Petersburg., 2009— Source: <http://www.dissertat.com/content/kolebaniya-krylavsverkhzvukovom-potoke-gaza-0>
- [10] H. Blasius, Über Schwingungserscheinungen an Einholmigen Unterflügeln, Zeitschrift für Flugtechnik und Motorluftschiffahrt, vol. 16, pp. 39-45. 1925.
- [11] A.S. Volmir, Nonlinear dynamics of plates and Covers" (In Russian). Ed by Kildibekov IG. Moscow: Nauka Publisher, 1972.
- [12] A. G. Gorshkov, V.I. Morozov, A.T. Ponomarev, F.N. Shklyarchuk, Aero hydroelasticity of designs (In Russian). Moscow: Fizmatlit Publisher, 2000.
- [13] V.Ya. Modorskiy, Yu.V. Sokolkin, Gas-elastic processes in power installations (In Russian). Ed by YuV Sokolkin. Moscow: Nauka Publisher, 2007.
- [14] N. V. Shuvaev, Numerical modeling methodology for the aeroelastic interaction of the gas turbine engine compressor blades with the subsonic ram air stream (In Russian). : Ph.D. thesis in Engineering Science. – Perm, 2014 . – 133 p. (Методика численного моделирования аэроупругого взаимодействия компрессорных лопаток газотурбинного двигателя с дозвуковым набегающим потоком воздуха).
- [15] Y. Galerkin, A. Rekestin, K. Soldatova, Aerodynamic Designing of Supersonic Centrifugal Compressor Stages, World Academy of Science Engineering and Technology, International Journal of Mechanical, Aerospace, Industrial, Mechatronic and Manufacturing Engineering Vol:9, No:1, 2015, pp. 123-127.
- [16] Y. B. Galerkin, E. Y. Popova, K. V. Soldatova, Calculation Analysis of an Axial Compressor Supersonic Stage Impeller, World Academy of Science Engineering and Technology International Journal of Mechanical, Aerospace, Industrial, Mechatronic and Manufacturing Engineering Vol:9, No:1, 2015, pp. 118-122.
- [17] Y. Galerkin, O. Solovieva, Flow Behavior and Performances of Centrifugal Compressor Stage Vaneless Diffusers, World Academy of Science Engineering and Technology, International Journal of Mechanical, Aerospace, Industrial, Mechatronic and Manufacturing Engineering Vol:9, No:1, 2015, pp. 128-133.
- [18] R. A. Zagitov, N. V. Shuvaev, A. N. Dushko, Y. N. Shmotin Numerical Simulation of Unsteady Flow Around Oscillating Blade, Proceedings of ASME Turbo Expo 2012, June 11-15, Copenhagen, Denmark, 2012. – GT2012- 69458
- [19] Ch. Xiangying, Zh. Ge-Cheng, Ya. Ming-Ta, Numerical simulation of 3-D wing flutter with fully coupled fluid–structural interaction, Computers & Fluids, vol. 36, pp. 856–867. 2007.
- [20] Z. Jianping, G. Liang, W. Helen, Zh. Aixi, H. Danmei, R. Jianxing, The influence of wind shear on vibration of geometrically nonlinear wind turbine blade under fluid–structure interaction, Ocean Engineering, vol. 84, pp. 14-19. 2014.
- [21] D. H. Kim, Y. H. Kim, Performance Prediction of a 5MW Wind Turbine Blade Considering Aeroelastic Effect, World Academy of Science Engineering and Technology, International Journal of Mechanical, Aerospace, Industrial, Mechatronic and Manufacturing Engineering Vol:5, No:9, 2011, pp. 1855-1859.
- [22] S.P. Kopysov, L.E. Tonkov, A.A. Chernova, Bilateral binding when modeling interaction of a supersonic stream and deformable plate. Comparison of numerical schemes and results Experiment (In Russian). Computational Continuum Mechanics, vol. 6, no. 1, pp. 78-85. 2013.
- [23] J. Giordano, G. Jourdan., Y. Burtshell, M. Medale, D.E. Zeitoun, L. Houas, Shock wave impacts on deforming panel, an application of fluid-structure interaction, Shock Waves, vol. 14, no. 1-2, pp. 103-110. 2005. DOI 10.1007/s00193-005-0246-9.
- [24] ANSYS Structural Analysis Guide, Release 15.0. Source: <http://www.ansys.com/>.
- [25] E. Wang, T. Nelson, Structural Dynamic Capabilities of ANSYS. Source: <http://easc.ansys.com/staticassets/ANSYS/staticassets/resource library/confpaper/2002-Int-ANSYS-Conf-200.PDF>.

Evgeniia V. Mekhonoshina was born in Belorussian Soviet Socialist Republic in 1991. In 2013, she graduated with honors from Perm National Research University (PNIPU), Perm, Russia. In the same year, she took a postgraduate course at PNIPU, Perm, Russia.

Since 2013, she has been working as an engineer in the High-performance Computer Systems Centre at PNIPU, Perm, Russia. The main papers: On a phase-shift of waves at the medium interface (Samara, Russia: Computer Optics, 2015), a section of the multi-authored monograph, Solving of the engineering problems using the high-performance computer complex of Perm

National Research University. (Perm, Russia: PNIPU publishing office, 2013) («Решение инженерных задач на высокопроизводительном вычислительном комплексе Пермского национального исследовательского политехнического университета»), Numerical evaluation of the stress-strain state of compressor blade in the aeroelastic formulation (Kazan, Russia: Scientific and Technical Bulletin of the Volga Region, 2015). The area of her scientific interest is related to aeroelasticity, vibrations and numerical modeling.

Miss Mekhonoshina won the open competition for award of Lobachevsky State University of Nizhny Novgorod for postgraduate students and students in master's programs of Russian and foreign higher educational institutions and scientific organizations (2014). The oral report named "Numerical evaluation of the compressor blade stress strain behavior in the aeroelastic statement" made by Evgeniia V. Mekhonoshina in the scientific and technical conference in Perm, October 2015, was awarded by the III degree Diploma.

Vladimir Ya. Modorskii, born 1964. In 1987, graduated with honour from Perm Polytechnic Institute (PPI, at present Perm National Research University (PNIPU), Perm, Russia. From 1993 to 1995, he took a full-time postgraduate study in Perm State Technical University. In 1995, Vladimir Ya. Modorskii defended a PhD thesis in Engineering Science at Perm State Technical University. In 1998, Vladimir Ya. Modorskii was assigned an assistant professor academic status.

Since 1995, Vladimir Ya. Modorskii has been working as a Deputy Dean for academic affairs. In 2007, he defended a doctoral thesis. Since 2005, he has been working as a Director of the AMD-PNIPU regional technical competency center; since 2007, he has been working as a professor of PNIPU, in 2008, he became a Director of the High-performance Computer Systems Centre at PNIPU, Perm, Russia. The main papers are the following: the monograph "Computational investigation of the urgent problems of machine manufacturing and mechanics of continuous and granular media using the large-particle method: monograph" ("Численное исследование актуальных проблем машиностроения и механики сплошных и сыпучих сред методом крупных частиц: монография") / Yu.M. Davydov [and others]. – M.: National Academy of Applied Sciences, International association of the large-particle method users and developers, 1995. – 1595 p.; "Modeling of cooling processes in the variable section channel of a gas conduit", Kozlova A.V., Modorskii V.Ya., Ponik A.N. // RUSSIAN AERONAUTICS. – 2010. – No. 4 (53). – P. 401-407; "Numerical modeling of flow mixing and cooling processes in a perforated exhaust duct", Kozlova A.V., Modorskii V.Ya., Sokolkin Y.V., Ponik A.N. // Russian Aeronautics, 57(2), 2014. - pp. 181-186. The scope of Mr. Vladimir Ya. Modorskii's scientific interest includes the problems of numerical and experimental modeling of the aeroelasticity processes, gas- and hydroelasticity, and evaluation of the structures' stress strain behavior, programming and high-performance computations, etc.

In 2000-2001, Mr. Modorskii was awarded a study grant from the Perm Region Administration for his achievements in the scientific field. In 2001, Vladimir Ya. Modorskii was elected a corresponding member of the Russian Academy of Natural Sciences (RAEN). Vladimir Ya. Modorskii took part in implementation of the scientific programmes of the Ministry of Education of the Russian Federation. In 2003, Vladimir Ya. Modorskii was awarded the Certificate of Merit from the Ministry of Education of the Russian Federation. In 2011, he was awarded the Letter of Gratitude from the Perm Territory Governor and the Certificate of Merit from the Minister of Industry of the Perm Territory. Vladimir Ya. Modorskii is a scientific coordinator of the Grant of the Russian Scientific Foundation "Numerical modeling of the GTU rotors dynamical stability, with due consideration of the heat and gas-dynamic loads" and of the Grant of Russian Fundamental Research Fund "Technological platform of the experimental and computing studies of the high-speed hydroelasticity process on the basis of a Super Computer" (2014 to 2016), etc.

Vasilii Yu. Petrov, born 1946. In 1970, he graduated from the Department of Mechanical Engineering of Perm State Polytechnic Institute, Russia. In 1979, Vasilii Yu. Petrov defended the Ph.D. thesis related to the research of problems of the structure manufacturing technologies, which was carried out on the basis of the composite materials in Leningrad military mechanical institute. In 2000, Vasilii Yu. Petrov defended a doctoral thesis, and in 2002, he was assigned a doctor degree in technical sciences.

Since 1972, Vasilii Yu. Petrov has been working in Perm State Technical University (PGTU, at present Perm National Research University (PNIPU)). At first, he took a teaching assistant position in the chair of Machinery Technologies. In 1985, Vasilii Yu. Petrov became a dean of the Motor-Road Department of PGTU, Russia. Within the period from 1992 to 2000, Vasilii

Yu. Petrov was holding a position of Prorector for academic affairs in PGTU. In 2000, he was elected a Rector of PGTU. Since 2011, he is holding a position of the President of PNIPU, Russia. The scope of Vasilii Yu. Petrov's scientific interest covers the problems of industrial production and environment conservation, interdisciplinary problems.

Mr. Petrov is a corresponding member of the Russian Ecological Academy and a member of a board of the Department for Education and Science in the Perm Regional Administration.