

Enhance the Modeling of BLDC Motor Based on Fuzzy Logic

Murugan Marimuthu, Jeyabharath Rajaih

Abstract—This paper describes a simple way to control the speed of PMSM motor using Fuzzy logic control method. In the conventional PI controller the performance of the motor system is simulated and the speed is regulated by using PI controller. These methods used to improve the performance of PMSM drives, but in some cases at different operating conditions when the dynamics of the system also vary over time and it can change the reference speed, parameter variations and the load disturbance. The simulation is powered with the MATLAB program to get a reliable and flexible simulation. In order to highlight the effectiveness of the speed control method the FLC method is used. The proposed method targeted in achieving the improved dynamic performance and avoids the variations of the motor drive. This drive has high accuracy, robust operation from near zero to high speed. The effectiveness and flexibility of the individual techniques of the speed control method will be thoroughly discussed for merits and demerits and finally verified through simulation and experimental results for comparative analysis.

Keywords—Hall position sensors, permanent magnet brushless DC motor, PI controller, Fuzzy Controller.

I. INTRODUCTION

THE brushless dc motor drives have been widely used in electric vehicles, robotics and chemical industrial applications. In recent years the Brushless dc motors are preferred as small horsepower control motors due to their high efficiency, reliability and low maintenance. The conventional controllers are being used for some control applications. The mathematical model is essential for the system in designing the controllers for practical applications [1]. In the shaft position sensors the Hall Effect sensors are usually used to detect the rotor position. The brushless DC motor has trapezoidal Electro Motive Force (EMF) and quasi-rectangular current waveforms. Hall Effect sensors are usually used for every 60 degree electrical positions. In addition to the servo drive application with high stationary accuracy of speed and rotor position, the brushless DC motor which requires a rotor position sensor and absolute encoder. Recently, DC motors have been gradually replaced by the BLDC motors as industrial applications require more powerful actuators in small sizes were the Elimination of brushes and commutators also solves the problem which are associated with contacts and improved reliability and enhances long life [2]. The BLDC

motor has low inertia, very large power to volume ratio and low noise, when compared to the permanent magnet DC servo motor having the same output rating.

The conventional PI controller is one of the most common approaches for speed control in industrial electrical drives due to its simplicity. It also the basis for many advanced control algorithms and their strategies. These control strategies are fixed gains may perform as well for different operating conditions but not for all conditions, because the involved processes are in general complex, time variant and non-linearity as well as uncertainties. In fact, the PI speed controller has some main disadvantages such as load disturbance, parameter variations to increasing inertia and rotor resistance variations [3]. Based on the proposed control technique in order to improve the dynamic performance and control robustness. This technique is one of the most successful expert system technique applied in a wide range of control applications. It also combines with conventional PI controller to build fuzzy tuning controllers and in order to achieve a more robust control. However the fuzzy adaptation can be built and updating the fuzzy sets functions, fuzzy control rules and controller gains.

The contribution of this paper is a simple and high performance hence fuzzy tuned PI speed controller of the BLDC motor. The fuzzy rules which update the two gains of the PI controller with fixed structure and it based on a qualitative knowledge and also established from a lot of simulation results of several transient speed responses obtained for different operating conditions such as response to step speed command from standstill conditions. The conventional controllers are being used for some control applications. The responses of the system are found to be complex and nonlinear form. As the linear systems are approximated to obtain their mathematical model and the controller are designed for such systems may give the satisfactory as dynamic responses and the transient steady state responses but there is no optimum responses [4]. In some of the literatures, the system parameters never changes during the operating conditions it has been assumed but for the practical applications the mechanical parameter such as the inertia and the friction changes due to their decoupling inertia elements. The ratio of no load based to the full load friction and the inertia changes [5] from 10-20 times due to decoupling inertia for the positioning applications. The disadvantage for the conventional controllers is load disturbance and the parameter variations etc.

The system parameters which are designed, can provide better transient steady state responses while remain

Murugan Marimuthu is with the Department of Electrical and Electronics Engineering, K. S. Rangasamy College of Technology, Tiruchengode – 637215, Tamilnadu, India (e-mail: marimurugan@rediffmail.com)

Jeyabharath Rajaih is with the Department of Electrical and Electronics Engineering, K. S. R. Institute for Engineering and Technology, Tiruchengode – 637215, Tamilnadu, India (e-mail: jeya_psg@rediffmail.com).

unchanged. Almost in the system the parameters changes practically for their responses during the operating conditions [6]. The pulse width modulation and digital control schemes for the BLDC motor controller is the most commonly used methods for electric applications. Hysteresis current controller is used to maintain the actual currents flowing into the motor to close as possible to the rectangular reference value [7]. The dynamic performance of the BLDC motor system, the effect of change in motor parameters The system parameters which are designed can provide better transient steady state responses while remain unchanged [8], [9]. In the PI controller several tuning methods are described in [10]. For the level of desired results, the several tuning method [11] and hence in these methods are adapted for determining PI controller for the parameter gain. While modeling and the dynamic performance analysis of fuzzy logic control (FLC) for various applications in the BLDC motor drive and the drive has a trapezoidal back EMF and the rectangular stator currents are needed to produce a constant electric torque. [12].

The PID based method for the determination of PI controller parameters for achieving the dynamic performance. It is based on some control schemes used to compensate for the dynamic uncertainties in the motor drive [13]-[18]. The phase resistance of the BLDC motor slightly changes due to their terminal resistance where there are some changes in winding resistance and on-state resistance of the semiconductor switching devices due to temperature changes during operating conditions. The system parameters which are designed and it can provide better transient steady state responses while remain unchanged. Almost in the system the parameters changes practically for their responses during the operating conditions.

II. BLOCK DIAGRAM OF PROPOSED MODEL

Fig. 1 describes the block diagram of BLDC motor using FLC. The motor drive consists of speed controller, reference current generator, the PWM current controller, position sensor, were the motor and IGBT based current controlled voltage source inverter. The speed of the motor is compared with the reference value and the speed error is processed in FLC speed controller. The output for this controller is considered as the reference torque and the limit is put on the speed controller output depending on the permissible maximum winding currents. While the reference current generator block this generates the three phase reference currents using the limited peak current magnitude decided by the controller and the position sensor. The references current have the shape of quasi-square wave in phase with respective back EMF and also develop the constant unidirectional torque. The reference currents the motor currents are compared with the reference currents and the switching commands are generated to drive the inverter devices.

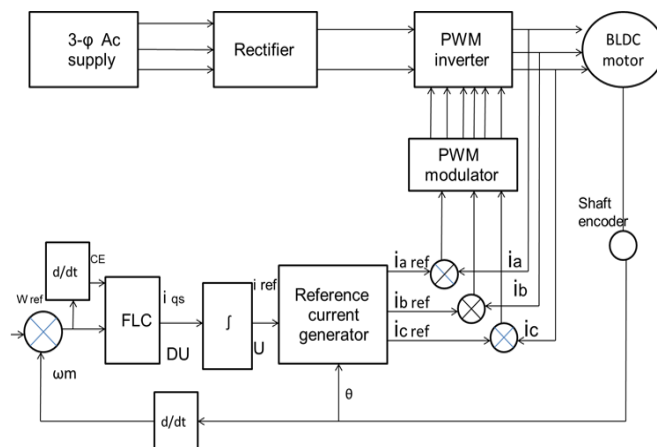

Fig. 1 Block Diagram of BLDC Motor using FLC

III. MODELING OF BLDC MOTOR DRIVE

Permanent Magnet machines are electromechanical devices which use magnets to produce a magnetic flux in the air-gap. These Permanent Magnet machines are categorized into two types based on flux density distribution and the shape of current excitation. They are;

- Brushless Alternating Current machines (BLAC), which have uniformly rotating stator field inducing sinusoidal back EMF.
- Brushless Direct Current machines (BLDC), which have trapezoidal back EMF.

Permanent Magnet machines have a stator constituted of copper windings distributed in three phases, and a rotor made of iron and permanent magnets. BLDC motors are widely classified into three types depending on the magnet position in the rotor and they are surface mounted magnet, inset magnet and buried magnet. Out of these three types, surface mount Permanent Magnet machines are cheaper because the rotor is only made of iron and the magnets are simply glued on afterwards. The positioning of the magnets increases the mechanical strength of the rotor, and makes the machine suitable for very high-speed operation through flux weakening.

In Permanent Magnet (IPM) machines, the reluctance of the magnetic flux path varies according to the rotor position. Due to the inductance, the control for an IPM machine is more difficult than surface mount Permanent Magnet machine. Hence, surface mount Permanent Magnet motors are more common in practical applications. The model provides a platform to design an electrical system to estimate rotor position of the motor. Given the non-sinusoidal flux distribution, a model of the surface mount BLDC motor in phase variables is derived. The equivalent circuit of BLDC motor with three phase six switch inverter is shown in Fig. 2. The model of BLDC motor involves line currents, line back-EMF and the line voltages of the motor. In loop a-n-b of considering switches S_1 and S_4 are switched ON; the voltage between nodes 'a' and 'n' is given by

$$V_{an} = R(i_a) + L \frac{d}{dt}(i_a) + E_{an} \quad (1)$$

and voltage between node b and n is written as

$$V_{bn} = R(i_b) + L \frac{d}{dt}(i_b) + E_{bn} \quad (2)$$

The difference between phase voltages (V_{an} and V_{bn}) constitutes to line voltage V_{ab}

$$V_{ab} = R(i_a - i_b) + L \frac{d}{dt}(i_a - i_b) + E_{ab} \quad (3)$$

Similarly, line voltages V_{bc} and V_{ca} are obtained by turning ON appropriate switches of the inverter.

$$V_{bc} = R(i_b - i_c) + L \frac{d}{dt}(i_b - i_c) + E_{bc} \quad (4)$$

$$V_{ca} = R(i_c - i_a) + L \frac{d}{dt}(i_c - i_a) + E_{ca} \quad (5)$$

The above equation is re-written as

$$\frac{d}{dt}(i_a - i_b) = -\frac{R}{L}(i_a - i_b) - \frac{1}{L}E_{ab} + \frac{1}{L}V_{ab} \quad (6)$$

$$\frac{d}{dt}(i_b - i_c) = -\frac{R}{L}(i_b - i_c) - \frac{1}{L}E_{bc} + \frac{1}{L}V_{bc} \quad (7)$$

$$\frac{d}{dt}(i_c - i_a) = -\frac{R}{L}(i_c - i_a) - \frac{1}{L}E_{ca} + \frac{1}{L}V_{ca} \quad (8)$$

Hence, (2) and (3) are modified as

$$\frac{d}{dt}E_{ab} = 0 \quad (9)$$

$$\frac{d}{dt}E_{bc} = 0 \quad (10)$$

If the sampling period is significantly less than the electrical and mechanical time constants then the back EMF can be assumed to be constant during each sampling period and hence the time derivative of the back EMF equals zero as shown in (9) and (10).

The third back EMF E_{ca} between the two phases (c and a) is deduced using

$$E_{ab} + E_{bc} + E_{ca} = 0 \quad (11)$$

The electromagnetic torque is given by

$$T_e = \frac{(E_a \cdot i_a + E_b \cdot i_b + E_c \cdot i_c)}{\omega_m} \quad (12)$$

The equation of motion is

$$\frac{d}{dt}\omega_m = \frac{(T_e - T_L - B \cdot \omega_m)}{J} \quad (13)$$

The amplitude of back EMF is proportional to the rotor speed, and is given by

$$E = k \cdot \omega_m \quad (14)$$

IV. CONTROLLING OF BLDC MOTOR DRIVE

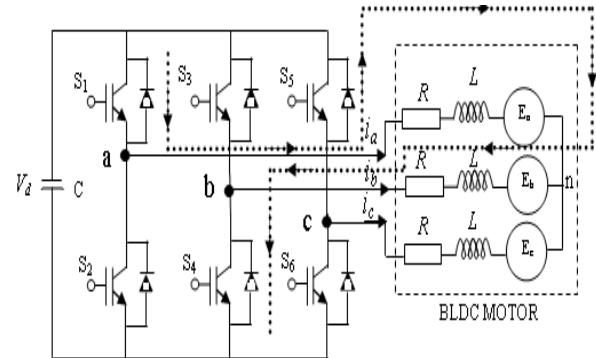

Fig. 2 BLDC Motor Drive with Inverter

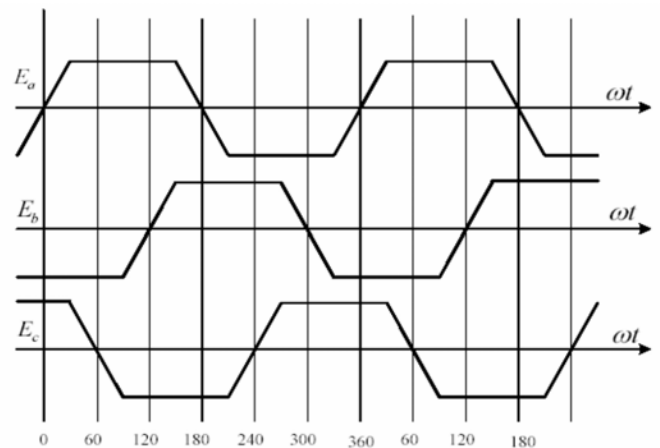

Fig. 3 Phase currents (i_a, i_b, i_c) of BLDC motor

While controlling the speed of the BLDC motor drive system it needed the rectangular stator current to produce a constant electric torque. With the small parameters perturbation technique observers is developed for the position and the speed measurements of the current. The state of art is the speed enhancement which depends upon the electromotive force and the flux linkage. It established the performance prediction over the wide range of operating conditions. The Hall Effect sensor which senses the rotor position because the controller must direct the rotor rotation were the controller which needs the rotor position relative to the stator coils.

In BLDC motor at any instant only two of the three phases conducts the current. This current conduction depends upon the rotor position of the motor. Usually, Hall sensors are used to determine the rotor position of the motor. The digital

signals from these Hall sensors are then used to determine the rotor position and switch gating signals for the inverter switches. Switching sequence of the inverter switches in accordance with the Hall sensor output is shown in Table I. The switching pulses for clock-wise rotation of motor are shown in Fig. 3. The pulses to the top switches of inverter are chopped according to the required speed while the bottom switches are switched ON for 120° electrical.

TABLE I
SWITCHING SEQUENCE

Hall A	Hall B	Hall C	Clockwise Rotation (abc)		Counter Clockwise Rotation (abc)	
1	0	0	S ₁	S ₆	S ₅	S ₄
1	0	1	S ₁	S ₂	S ₅	S ₆
0	0	1	S ₃	S ₂	S ₁	S ₆
0	1	1	S ₃	S ₄	S ₁	S ₂
0	1	0	S ₅	S ₄	S ₃	S ₂
1	1	0	S ₅	S ₆	S ₃	S ₄

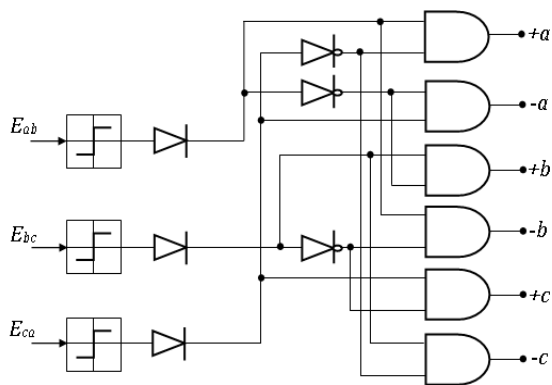

Fig. 4 Estimation of six commutation points

In this scheme of rotor position estimation, the outputs of the proposed method provide an estimate of the line back EMF. The estimated back EMF is then fed to the ZCDs to estimate the commutation points. The detection of the six rotor positions of the motor can be easily determined from the estimated line back-EMFs. For instance, during the commutation of transistor 'S_a', one can deduce that the line back-EMF E_{ab} is always positive and the line back-EMF E_{ca} is always negative. This means that it is possible to obtain a sufficient condition to switch ON the transistor 'S_a', it is enough to have $E_{ab} > 0$ and $E_{ca} < 0$. Similarly, for the other switching commutations, the same logic is employed. Based on this logic a digital circuit as shown in Fig. 4 is developed to find the commutation points. The rotor speed estimation with the help of mathematical relationship between speed and estimated back EMF. The magnitude of the back EMF is calculated and then with the back EMF constant, speed is being estimated as

$$\omega_r = \frac{E_{\max(\text{line})}}{2K_{EMF}} \quad (15)$$

$$E_{\max(\text{phase-to-neutral})} = \omega_r \cdot K_{EMF} \quad (16)$$

In other words,

$$E_{\max(\text{phase-to-neutral})} = \frac{E_{\max(\text{line})}}{2} \quad (17)$$

Using the estimated line back-EMF from sliding-mode observer and the six commutations points determined through the ZCD block, the amplitude of the line back EMF is obtained as depicted in Fig. 5.

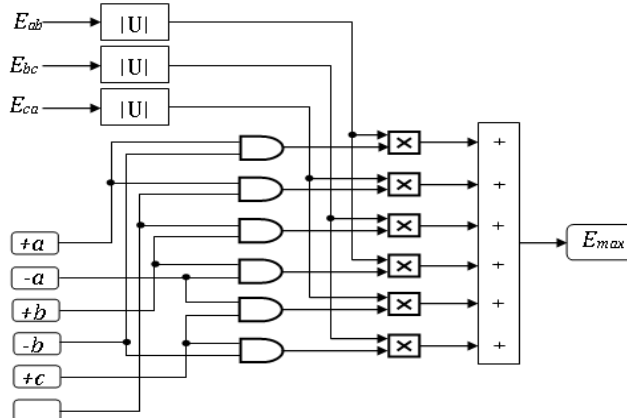

Fig. 5 E_{\max} Detection Circuit

V. IMPLEMENTATION OF FUZZY LOGIC CONTROLLER

The FLC is designed based on a simple analogy between the control surfaces of the FLC and a given Proportional-Integral controller for the same application. Fuzzy logic control may improve the quality of the speed response when compared to PI control. In case of permanent magnet motors usually speed control is achieved by using Proportional-Integral (PI) controller. PI controllers are widely used in the industry due to their simple control structure and ease of implementation these controllers have difficulties where there are some control complexity such that the nonlinearity, load disturbances and parameter variations. Moreover the PI controllers require precise linear mathematical models. In the Fuzzy logic controller it can model nonlinear systems. The design of conventional control system essential is normally based on the mathematical model of plant.

Fuzzy logic controller has adaptive characteristics. The adaptive characteristics can achieve robust performance to system with uncertainty parameters variation and load disturbances. In Fuzzification interface measures the values of input variable. It performs the function of Fuzzification that converts input data into suitable linguistic values. The inputs of the fuzzy controller are expressed in several linguist levels. As shown in Fig. 3 the seven of fuzzy membership function. As these levels can be described as Positive big (PB), Positive medium (PM), Positive small (PS) Negative small (NS), Negative medium (NM), Negative big (NB) or in other levels. Each level is described by fuzzy set.

In fuzzy Membership Function of a fuzzy set is a generalization of the indicator function in classical sets as

shown in Fig. 6. In the fuzzy logic control it represents the degree of truth as an extension valuation. Degrees of truth are often confused with probabilities, were they are conceptually distinct, because the fuzzy truth represents membership in defined sets, not as condition. Table II is used to frame the given rules. Based on the fuzzy variables selected the observation of the behavior of human operators and error the fuzzy rules base that can ensure the stability and steady state precision. The membership function input variable of error, change in error and the output variable of the reference torque are shown.

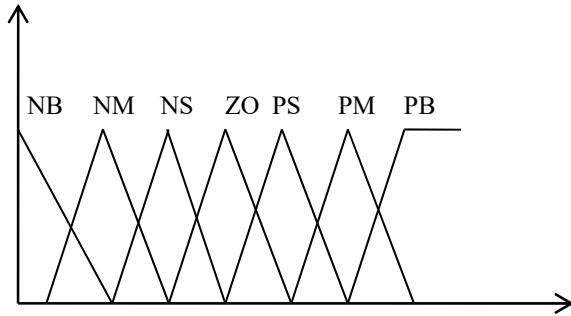

Fig. 6 Seven Levels Fuzzy Membership Function

To improve the dynamic performance and to overcome the problem the FLC is used. The fuzzy logic controller gets two inputs, one is error in speed in speed which is the difference between the actual speed and reference speed and another one is change in error, which is the difference between present error and previous error. Based on the inputs the fuzzy logic

controller gives the output to trigger the inverter switch when the input to fuzzy logic controller varies when the load varies. The membership function of a fuzzy set is generalization of the indicator function in classical sets. The membership function input variable of error, change in error and the output variable of reference torque.

TABLE II
 SPECIFICATIONS ADOPTED FOR THE SIMULATED INVERTER

e/ce	NB	NM	NS	ZO	PS	PS	PB
NB	NB	NB	NB	NM	NS	ZO	PS
NM	NB	NB	NB	NM	NS	ZO	PS
NS	NB	NB	NM	NS	ZO	PS	PM
ZO	NB	NM	NS	ZO	PS	PM	PB
PM	NS	ZO	PS	PM	PB	PB	PB
PB	ZO	PS	PM	PB	PB	PB	PB

VI. SIMULATION MODEL OF PROPOSED METHOD

The simulation model of closed loop fuzzy controller is designed and it is presented below. Fig. 7 shows the simulation diagram of BLDC motor using fuzzy logic controller. The DC source is connected to the inverter input and the gate pulses are given from the hall signals. From the inverter the output is given to the BLDC motor. Instead of PI controller Fuzzy logic controller is used for the speed regulation. The speed error is given as the input for the Fuzzy Logic Controller. The speed error is computed by comparing the reference speed and the actual speed of the BLDC motor. Fuzzy Logic Controller output is used for the reference current generation which is compared with the actual current and given to the hysteresis controller.

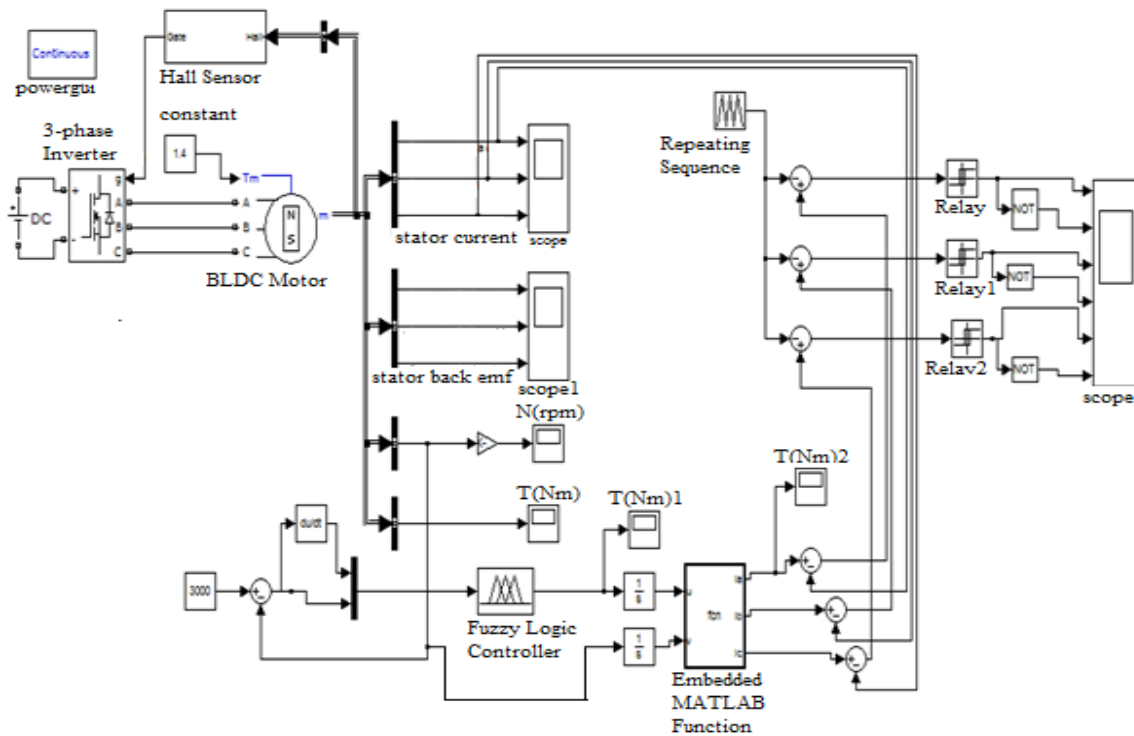

Fig. 7 Simulation Diagram of BLDC motor using Fuzzy Logic controller

VII. RESULTS AND DISCUSSION

The speed control of the proposed BLDC drive system using fuzzy logic controller is shown in Fig. 10. This method is tested by varying the load of the motor. The motor is operated at 1000 rpm with a load of 0.2 A. At rest stage the reference speed is set at 400rpm in motor with a settling time 0.02 seconds, the motor speed reaches the reference speed with a percentage overshoot of 6.667 with PI controller in Fig. 8. The motor is loaded to 0.4 A at $t=0.5$ sec. The speed returns to the original level within 0.3 seconds of loading which is depicted then the load is reduced to 0.2 A at $t=1.1$ s in Fig. 9. Hence, the speed of the motor depends with respect to the variation of the load. The phase currents at the time starting getting transient due to initial phase back EMF machine are zero. After the speed reaching reference speed, phase currents are reaches the reference current. For FLC the motor speed reaches reference speed with settling time of 0.03 seconds in Fig. 10.

Fig. 11 shows the electromagnetic torque of BLDC motor using FLC and the peak value of rotor speed is 31 rpm. The settling time of the rotor speed is 2.23sec. When using FLC controller in the feedback circuit based on its present error and the FLC it performs the operation and gives the output signal. The speed response of the BLDC drive with conventional PI controller response of the drive is slower than that of FLC speed controller. The results prove that the response of the drive is faster with FLC controller than the conventional PI controller. Improved response in case of FLC controller is of immense help to industrial applications.

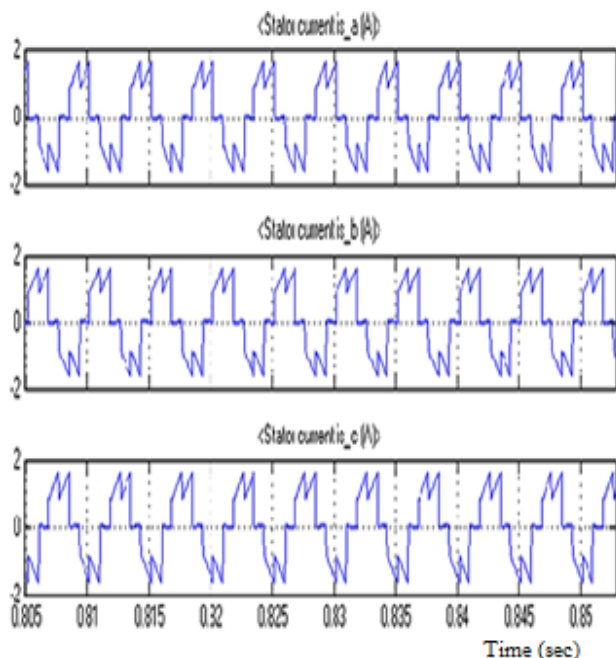

Fig. 8 Stator currents variation of BLDC motor using Fuzzy Logic Controller

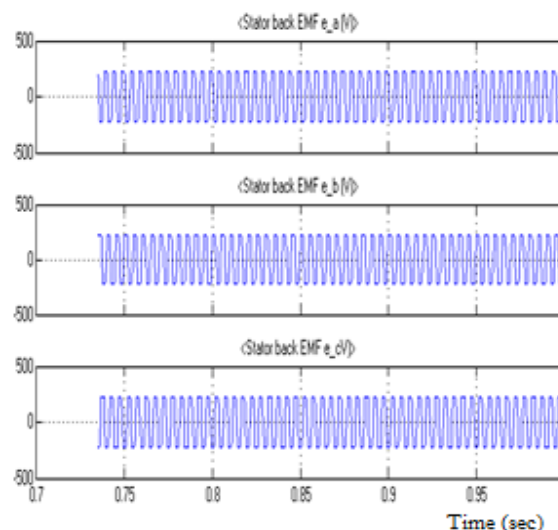

Fig. 9 Stator Back EMF of BLDC motor using FLC

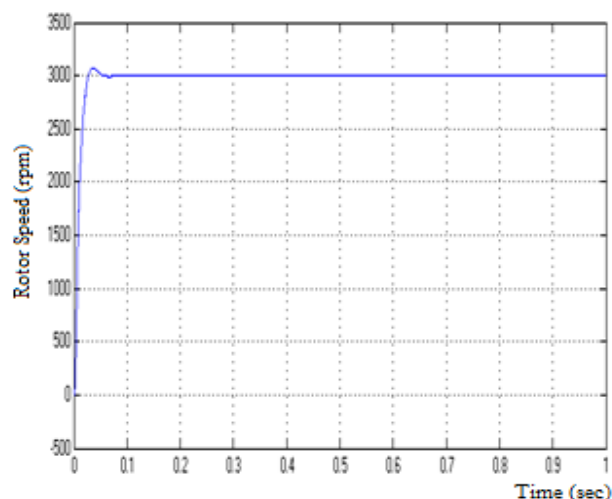

Fig. 10 Speed Response of BLDC motor using FLC

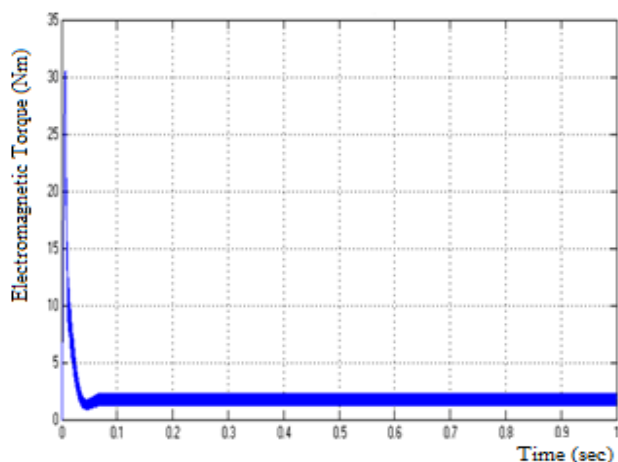

Fig. 11 Electromagnetic Torque of BLDC Motor using FLC

VIII. CONCLUSION

The investigation results of a BLDC motor using FLC

controller are presented. The main focus of conventional PI controller is to estimate the rotor position of the motor. In the presence of proposed FLC controller leads the unwanted parameter chattering in the estimated rotor position. The theoretical basis of the proposed scheme is carried out using MATLAB/SIMULINK to demonstrate the viability of the proposed strategy. The simulation has been carried out for different operating conditions using conventional PI controller and FLC controller. The simulation results of the two controllers are compared based on the settling time and rise time for steady state condition and for dynamic condition sudden change in load and set speed variation. This chattering problem is eliminated by using a FLC controller however in the FLC controller with the noted unaltered back EMF works well only for its designed range of speed. Hence the speed is incorporated in the FLC controller and performance is improved for all range of speeds. Thus, the performance of the Fuzzy Logic Controller is better than the other controller.

ACKNOWLEDGMENT

The author(s) would thank to Dr. P. Veena Department of Electrical and Electronics Engineering, KSR Institute for Engineering and Technology, Tiruchengode, for his valuable technical suggestion throughout this work, and Mrs. T. Anandhi for providing language help, writing assistance and proof reading the paper.

REFERENCES

- [1] B.-K. Lee, T.-H. Kim, and M. Ehsani, (2003) "On the feasibility of four-switch three-phase BLDC motor drives for low cost commercial applications: Topology and control," IEEE Transaction on Power Electronics vol. 8, no. 1, pt. 1, pp. 164–172.
- [2] S. Ogasawara and H. Akagi, (2009) "An approach to position sensorless drive for brushless dc motors," IEEE Transaction on Industrial Applications vol. 27, no. 5, pp.928–933.
- [3] H. Melkote and F. Khorrami, (1999) "Nonlinear adaptive control of directdrive brushless dc motors and applications to robotic manipulators," IEEE Transaction on Mechatronics, vol. 4, no. 1, pp. 71–81.
- [4] H. Grabner, W. Amrhein, (2010) S. Silber, and W. Gruber, "Nonlinear feedback control of a bearingless brushless dc motor," IEEE Transaction on Mechatronics, vol. 15, no. 1, pp. 40–47.
- [5] Seyed Mohammad Hossein Mousavi, Mehrdad Jafarboland, "Modeling the Dynamic Behavior of 9-Phase BLDC Motor and Examining the Effect of the Increased Number of Phases", International Review of Modelling and Simulation, Vol. 5 no. 3, pp. 1254-1265, June 2012.
- [6] R. Shanmugasundram, K. M. Zakariah, and N. Yadaiah, (2009) "Digital implementation of fuzzy logic controller for wide range speed control of brushless dc motor," in Proceedings IEEE International Conference on Vehicle Electronics Safety, Pune, India, Nov. 10–12, pp. 119–124.
- [7] P. Pillay and R. Krishnan, (1989) "Modeling, simulation, and analysis of permanent-magnet motor drives, part ii: The brushless dc motor drive," IEEE Transaction on Industrial Applications, vol. 25, no. 2, pp. 274–279.
- [8] Y.-W. Tu and M.-T. Ho, (2012) "Robust second-order controller synthesis for model matching of interval plants and its application to servo motor control," IEEE Transaction on Control Systems Technology, vol. 20, no. 2, pp. 530–537.
- [9] Lekshmi A., Sankaran R., Ushakumari S. "Modelling and Simulation of PM Brushless DC Motor Based Spooler Drive System with Speed and Current Feedback", International Review of Modelling and Simulation Vol. 5 N. 1, pp. 231-238, February 2012
- [10] Q. Wang, T. Lee, H. Fung, Q. Bi, and Y. Zhang, (1999) "PID tuning for improved performance," IEEE Transaction on Control Systems Technology, vol. 7, no. 4, pp. 457–465.
- [11] J. C. Basilio and S. R. Matos, (2002) "Design of PI and PID controllers with transient performance specification," IEEE Transaction on Edu. vol. 45, no. 4, pp. 364–370.
- [12] J.-W. Kim and S. W. Kim, (2003) "Design of incremental fuzzy PI controllers for a gas-turbine plant," IEEE Transaction on Mechatronics, vol. 8, no. 3, pp. 410–414.
- [13] M. Murugan, R. Jeyabharath and P. Veena, (2013) "Stability analysis of BLDC Motor based on Input Shaping" International Journal of Engineering and Technology, Vol No.5, pp -4339-4348
- [14] Rubaai, D. Ricketts, and M. D. Kankam, (2002) "Laboratory implementation of a microprocessor-based fuzzy logic tracking controller for motion controls and drives," IEEE Transaction on Industrial Applications, vol. 38, no. 2, pp. 448–456.
- [15] Y.-S. Lai, F.-s. Shyu, and Y.-H. Chang, (2004) "Novel loss reduction pulse width modulation technique for brushless dc motor drives fed by MOSFET inverter," IEEE Transaction on Power Electronics, vol. 19, no. 6, pp. 1646–1652.
- [16] R. Shanmugasundram, K. M. Zakariah, and N. Yadaiah. (2012). "Modelling, simulation and analysis of controllers for brushless direct current motor drives" Journal of Vibrations and Control, pp. 1–15.
- [17] K. Wallace and R. Spee, (1990) "The effects of motor parameters on the performance of brushless dc drives," IEEE Transaction on Power Electronics, vol. 5, no. 1, pp. 2–8.
- [18] V. M. Varatharaju, B. L. Mathur, and K. Udhayakumar, (2010) "Speed control of PMSM motor using MATLAB/Simulink and effects of load and inertia changes," in Proceedings on second International Conference on Mechanical and Electrical Technology, pp. 543–548.



M. Murugan was born in Tamil Nadu, India. He is graduated in 2002 from Madurai Kamarajar University, and post graduated in 2004 at Anna University, Chennai. He is a Research scholar in Anna University, Chennai. He is currently working as an Assistant professor in the department of EEE at K. S. Rangasamy College of Technology, Tiruchengode from June 2004 onwards. He is guiding UG, PG Students. He is an ISTE member. He published 5 international/national conferences. His research interest involves in Power Electronics and drives, Special Electrical Machines and Control Systems.



Dr. R. Jeyabharath was born in Tamil Nadu, India. He is graduated in 2001 from Madurai Kamarajar University, and post graduated in 2003 at Bharathiar University, Coimbatore, and he got doctoral degree in 2008 at Anna University, Chennai. He is currently working as a Professor in the department of EEE at K. S. Rangasamy College of Technology, Tiruchengode from June 2003 onwards. He is guiding UG, PG Students. He is an ISTE, IETE member. He published 15 international/national conferences, journals. His research interest involves in Power Electronics and drives, Special Electrical Machines and optimization techniques.