

A Two-Way Wilkinson Power Divider Realized Using One Eighth Wave Transmission Line for GSM Application

G. Kalpanadevi, S. Ravimaran, M. Shanmugapriya

Abstract—In this paper, a modified Wilkinson power divider for GSM application is presented. The quarter-wavelength microstrip lines in the conventional Wilkinson power divider (WPD) are replaced by one-eighth wavelength transmission line. Wilkinson power divider is designed using $\lambda/4$ and $\lambda/8$ transmission line. It has the operating frequency of 915 MHz which is used in the GSM standard. The proposed Wilkinson Power Divider is designed using the simulation tool Advanced Design System. The results of $\lambda/8$ transmission line are very close to the results of $\lambda/4$ transmission line. The isolation loss of $\lambda/8$ transmission line is improved by introducing a capacitor between the output ports. The proposed Wilkinson power divider has the best return loss of greater than -10 dB and isolation loss of -15.25 dB. The $\lambda/8$ transmission line Wilkinson power divider has the reduced size of 53.9 percentages than $\lambda/4$ transmission line WPD. The proposed design has simple structure, better isolation loss and good insertion loss.

Keywords—Wilkinson Power Divider, Quarter wave line, one eighth wave transmission line, microstrip line.

I. INTRODUCTION

POWER divider is a passive microwave component used as feeding network for antenna array, power amplifiers and also used as mixers, phase shifter, radar, measurement systems, etc. Among various kinds of power dividers, Wilkinson power divider is widely used because of its simple structure, better isolation, and design simplicity [1]. Both equal and unequal power division are possible in Wilkinson power divider. Power dividers with various arbitrary division ratios are designed [2].

The miniaturization of a microstrip Wilkinson power divider is achieved by substituting the quarter wave transmission lines employed in conventional Wilkinson power dividers with its equal circuit consisting of two stubs and an inductor [3]. Size reduction of the device length is achieved at 53% for the frequency of 2140MHz.

The feasibility of using FR4 is investigated via the testing of Wilkinson power dividers operating in portions of the L-band (1-2 GHz) [4]. The 1-2 GHz band serves significant

wireless applications such as cellular mobile and mobile satellite data. Double-sided parallel-strip lines and Defected Ground Structure (DGS) Wilkinson power divider for GSM applications are presented in [5], [6], [9].

An UWB Wilkinson power divider using tapered transmission lines is proposed [7]. Using tapered transmission lines in microwave components results in reduction of the element length. This power divider has superior performance in the UWB band (3.1GHz-10.6GHz) and is smaller in size as compared to traditional power dividers.

Two new compact Wilkinson power dividers are proposing is the first power divider that uses dual and T-shaped transmission lines to replace the two quarter-wavelength ($\lambda/4$) transmission lines in the conventional equal-split Wilkinson power divider. The second divider utilizes new dual transmission line section, which is composed of one single uniform and one T-shaped transmission lines, to replace each $\lambda/4$ transmission line in the conventional equal-split Wilkinson power divider [8].

The design of the Wilkinson power divider is more complicated to reduce the size of the power divider in previous techniques. To reduce the complexity of the design, a 2 way Wilkinson power divider is realized by using one eighth wave transmission lines. The conventional Wilkinson power divider is shown in Fig. 1. In the proposed WPD, $\lambda/4$ transmission line is replaced by $\lambda/8$ transmission line and it proves that the new proposed model has better isolation loss and good insertion loss with reduced size.

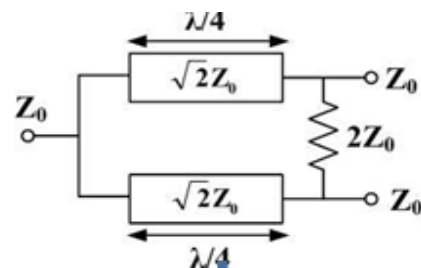

Fig. 1 Conventional Wilkinson power divider

II. DESIGN AND ANALYSIS

The proposed one eighth wave transmission line is designed by using the following techniques. The effective dielectric constant is a function of the relative permittivity of the substrate, the substrate thickness, and the conductor width. It can be approximately determined using (1):

G.Kalpanadevi is with Department of Electronics and Communication Engineering, M.A.M. College of Engineering., Trichy – 621 105, India. (Phone: 9443780910; e-mail: gkdmamce@gmail.com).

Dr. S. Ravimaran is with Department of Computer Science and Engineering, M.A.M. College of Engineering, Trichy – 621 105, India (Phone: 9443076222; e-mail: ssg_ravimaran@mamce.org).

Dr. M. Shanmugapriya is with Department of Electronics and Communication Engineering, M.A.M. College of Engineering., Trichy – 621 105, India (Phone: 9443633367; e-mail: ssg_priya@mamce.org).

$$\epsilon_{eff} = \frac{\epsilon_r + 1}{2} + \frac{\epsilon_r - 1}{2} * \left(\frac{1}{\sqrt{1 + 12D/W}} \right) \quad (1)$$

The effective dielectric constant can be interpreted as the dielectric constant of a homogeneous medium that replaces the air and dielectric regions of the microstrip.

The wavelength, λ_m (in millimetres) in the microstrip is related to the phase velocity and can be determined using:

$$\lambda_m = \frac{300}{F\sqrt{\epsilon_{eff}}} \quad (2)$$

where F is the intended frequency of operation in GHz.

With the dimensions of the microstrip line, the characteristic impedance can be calculated as

$$Z_0 = \begin{cases} \frac{60}{\sqrt{\epsilon_e}} \ln \left(\frac{8D}{W} + \frac{W}{4D} \right) & \text{for } \frac{W}{D} \leq 1 \\ \frac{120\pi}{\sqrt{\epsilon_e} [W/D + 1.393 + 0.667 \ln(W/D + 1.444)]} & \text{for } \frac{W}{D} \geq 1 \end{cases} \quad (3)$$

The characteristic impedance of a microstrip line is also related to the conductor width and dielectric thickness. More conveniently, the ratio of conductor width to dielectric thickness can be determined for giving characteristic impedance and relative permittivity using the following equations given [4]

$$\frac{W}{D} = \begin{cases} \frac{8e^A}{e^{2A} - 2} & \text{for } \frac{W}{D} < 2 \\ \frac{2}{\pi} \left[B - 1 - \ln(2B - 1) + \frac{\epsilon_r - 1}{2\epsilon_r} \left\{ \ln(B - 1) + 0.39 - \frac{0.61}{\epsilon_r} \right\} \right] & \text{for } \frac{W}{D} > 2 \end{cases} \quad (4)$$

$$A = \frac{Z_0}{60} \sqrt{\frac{\epsilon_r + 1}{2}} + \frac{\epsilon_r - 1}{\epsilon_r + 1} \left(0.23 + \frac{0.11}{\epsilon_r} \right) \quad (5)$$

$$B = \frac{377\pi}{2Z_0\sqrt{\epsilon_r}} \quad (6)$$

The width of microstrip line is

$$W = \text{calculated value} * D \quad (7)$$

The length of microstrip line is

$$l = \frac{90^\circ (\pi/180^\circ)}{\sqrt{\epsilon_e} K_0} \quad (8)$$

where

$$K_0 = \frac{2\pi f}{c} \quad (9)$$

where W=Width of microstrip line in mm; l=Length of microstrip line in mm; D=1.6, Thickness of FR4 Substrate in mm; ϵ_r =4.4, Relative permittivity $C^2 N^{-1} M^{-2}$; ϵ_e = Effective permittivity $C^2 N^{-1} M^{-2}$; f=915MHz, Operating frequency in MHz; c=Velocity of light in free space (m/s); λ_g = guided wavelength in mm.

The design of microstrip power divider is constructed using one input and two output ports which are terminated by 50 ohm impedance.

By using the above mentioned formulas the design parameters for conventional $\lambda/4$ transmission line and $\lambda/8$ transmission line is calculated and shown in Table I. It is observed that $\lambda/8$ transmission line has reduced length than the conventional $\lambda/4$ transmission line.

TABLE I
 COMPARISON BETWEEN $\lambda/4$ TRANSMISSION LINE AND $\lambda/8$ TRANSMISSION LINE PARAMETERS

Parameter	$\lambda/4$ Transmission line	$\lambda/8$ Transmission line
Length (L)	44.82 mm	22.41 mm
Width (W)	1.61 mm	1.61 mm
Radius (R)	29.27 mm	14.64 mm

The performance of the $\lambda/4$ transmission line power divider and proposed $\lambda/8$ transmission line power divider has been analyzed by using simulation tool and the results are listed in Table II.

TABLE II
 PERFORMANCE ANALYSIS OF $\lambda/4$ TRANSMISSION LINE AND $\lambda/8$ TRANSMISSION LINE PARAMETERS

Parameter	$\lambda/4$ Transmission line	$\lambda/8$ Transmission line
Return loss S_{11}	-30 dB	-16.83 dB
Isolation loss S_{23}	-29.482 dB	-15.25 dB
Insertion loss $S_{12}=S_{13}$	-3.115 dB	-3.49 dB
Area	11.5cm x 6.2cm	5.3cm x 4.3cm
Operating Frequency	915MHz	915MHz

From Table II, it is proved that proposed $\lambda/8$ transmission line Wilkinson power divider produces a size reduction of 53.9% of the conventional Wilkinson power divider. Also proposed $\lambda/8$ transmission line has better return loss and isolation loss. The proposed model has been fabricated by FR4 substrate with dielectric constant of 4.4.

III. SIMULATION AND MEASUREMENT RESULTS

The structure of the $\lambda/4$ transmission line Wilkinson power divider and proposed $\lambda/8$ transmission line Wilkinson power divider model is shown in Figs. 2 (a) and (b).

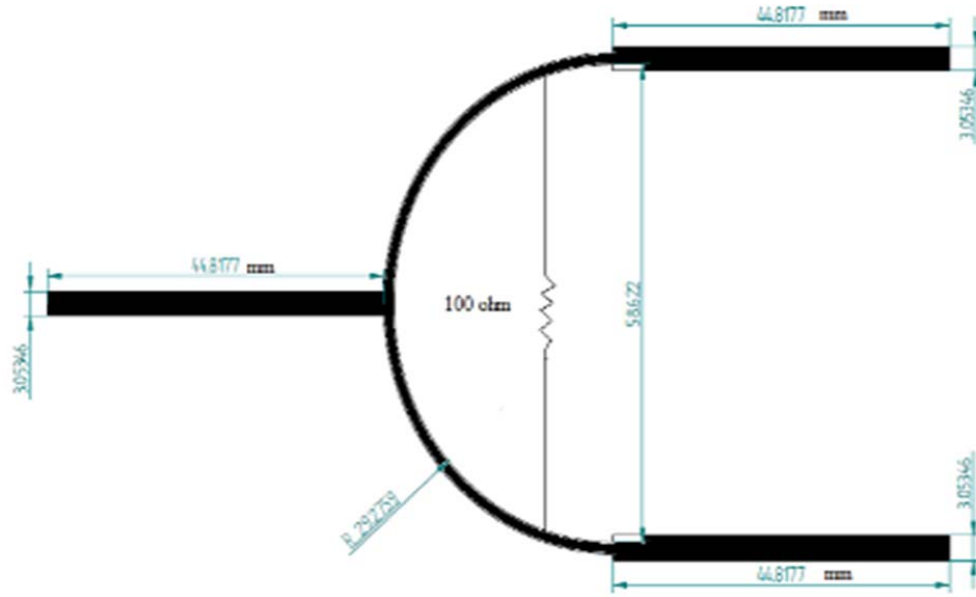

(a)

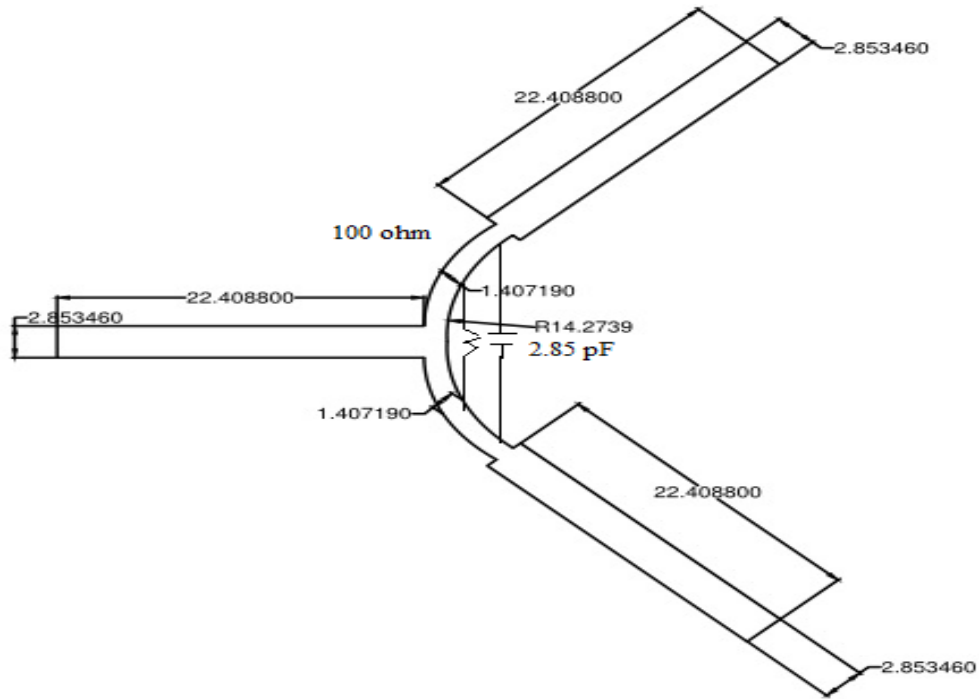

(b)

Fig. 2 Layout of the $\lambda/4$ transmission line Wilkinson power divider and $\lambda/8$ transmission line Wilkinson power divider respectively.

The simulation results of $\lambda/4$ and $\lambda/8$ transmission line Wilkinson power divider are shown in Figs. 3 (a) and (b). It shows that the proposed Wilkinson power divider has better return loss and isolation loss in the operating frequency of 915MHz.

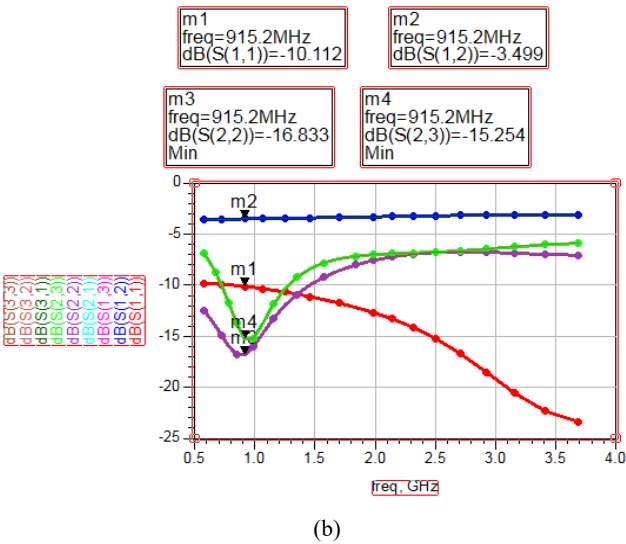
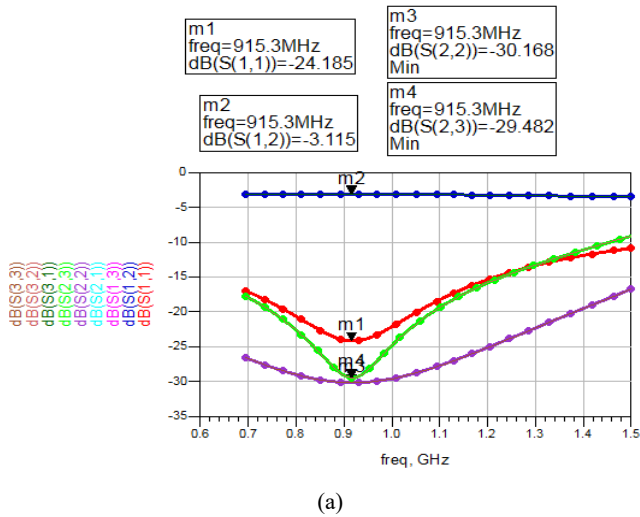

Fig. 3 Simulation results of the $\lambda/4$ transmission line Wilkinson power divider and $\lambda/8$ transmission line Wilkinson power divider respectively

The conventional $\lambda/4$ transmission line and proposed $\lambda/8$ transmission line Wilkinson power divider is fabricated by FR4 substrate and the fabricated prototype model is shown in Figs. 4 (a) and (b) respectively.

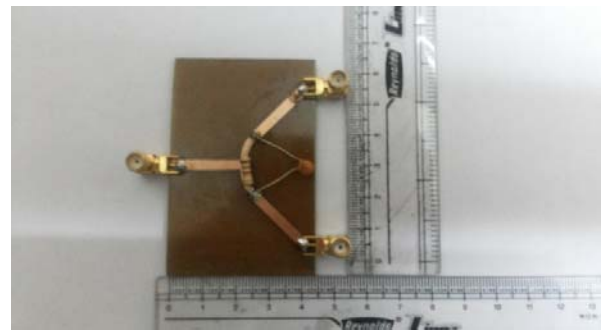
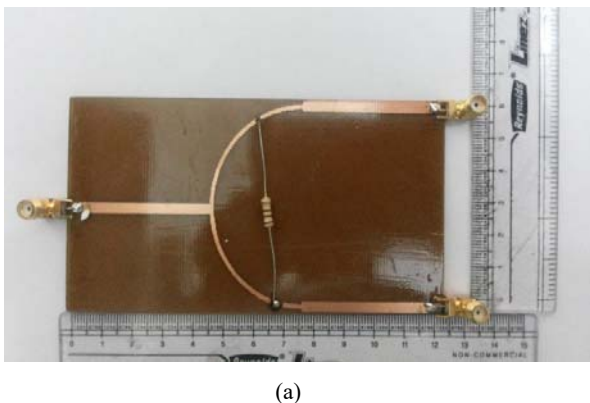

Fig. 4 Photograph of the fabricated model of the $\lambda/4$ transmission line Wilkinson power divider and $\lambda/8$ transmission line Wilkinson power divider respectively

The measurement results are shown in Fig. 5 and shows that the proposed Wilkinson power divider has a better insertion loss of -3dB, a good return loss of greater than -20 dB and isolation loss of greater than -10dB for the operating frequency of 915MHz. Deviation in simulation and measurement result occurs due to fabrication effect and connector losses. It is observed that the proposed power divider has good agreement between simulation and measurement results.

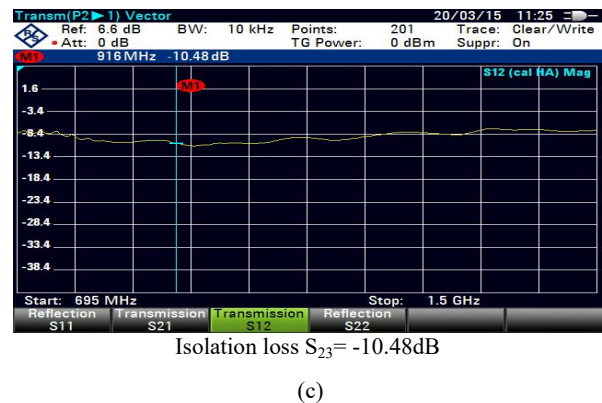
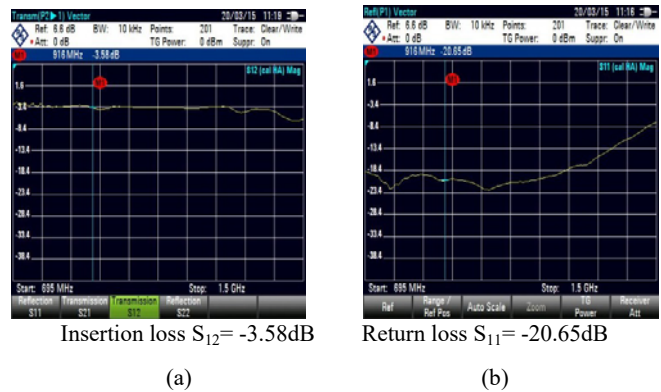

Fig. 5 Measurement results of the fabricated model of proposed $\lambda/8$ transmission line Wilkinson power divider

IV. CONCLUSION

The Wilkinson power divider realized using $\lambda/4$ transmission line has the area of 11.5cm x 6.2cm. The proposed Wilkinson power divider realized using $\lambda/8$ transmission line has the area of 5.3cm x 4.3cm. The proposed $\lambda/8$ transmission line Wilkinson power divider has a size reduction of 53.9% of the conventional Wilkinson power divider. The width and length of the microstrip line are based on the thickness of the substrate used. The design has simple structure, better isolation, and good insertion loss. The proposed $\lambda/8$ transmission line Wilkinson power divider is mainly designed for GSM application which has the operating frequency of 915MHz. The Wilkinson power divider that is realized using $\lambda/8$ transmission line has better input and output return loss of -16.833dB, insertion loss of -3.499 dB and isolation loss of -15.25 dB. Hence, $\lambda/8$ transmission line Wilkinson power divider has been designed with reduced size and better isolation loss.

REFERENCES

- [1] David M. Pozar, Microwave Engineering, Third Edition, pp 308-323, John Wiley and Sons, Inc., 2003.
- [2] Jia-Lin Li and Bing-Zhong Wang, "Novel Design of Wilkinson Power Dividers with Arbitrary Power Division Ratios," *IEEE Transactions on Industrial Electronics*, Vol. 58, No. 6, JUNE 2011, pp 2541-2546.
- [3] S. Shamsinejad, M. Soleimani, and N. Komjani, "Novel Miniaturized Wilkinson Power Divider For 3G Mobile Receivers", *Progress In Electromagnetics Research Letters*, Vol.3, pp 9-16, 2008.
- [4] Christos Kalialakis, "Feasibility of Microstrip Wilkinson Power Dividers on FR4 Substrates for L-Band (1-2 GHz) Applications", *High Frequency Electronics*, Vol 12(3), 03/2013, pp 24-28.
- [5] Lu, Yun Long, et al. "A Broadband Out-of-Phase Power Divider for High Power Applications Using Through Ground via (Tgv)", *Progress In Electromagnetics Research*, Vol.137, 2013, pp 653-667.
- [6] Gupta, Nisha, Pallabi Ghosh, and Megha Toppo, "A miniaturized Wilkinson power divider using DGS and fractal structure for GSM application", *Progress In Electromagnetics Research Letters*, Vol.27, 2011, pp 25-31.
- [7] Farooq Razzaz, Majeed A. S. Alkanhal, and Abdel-Fattah Sheta, "UWB Wilkinson Power Divider Using Tapered Transmission Lines", *PIERS Proceedings, Moscow, Russia*, August 19-23, 2012, pp 882-884.
- [8] Sung-Yen Juang, Li-Chi Dai, Yu-Ta Chen, Wen-Chian Lai, and Pu-Hua Deng, "New Wilkinson Power Dividers Using Dual and T shaped Transmission lines", *Progress In Electromagnetics Research Symposium Proceedings, Moscow, Russia*, August 19-23, 2012, pp 853-856.
- [9] S. A. Mohassieb, I. M. Barseem1, E. A.-F. Abdallah, and H. M. El-Hennawy, "A Compact Microstrip Power Divider Using Periodic DGS and HIOS", *Progress In Electromagnetics Research Symposium Proceedings, Xi'an, China*, March 22-26, 2010, pp 531-534.

G. Kalpanadevi has received her B.E in Electronics and Communication Engineering from Bharathidasan University, Trichirappalli, Tamil Nadu, India in 2003 and completed a Master Degree in Communication Systems from Anna University, Chennai, Tamil Nadu, India in 2011. Since 2013, she has been a research scholar, pursuing a PhD at Anna University, Chennai, Tamil Nadu; India. Now she is working as Associate Professor in the department of Electronics and Communication Engineering, M.A.M. College of Engineering, Trichirappalli, Tamil Nadu, India. Her main research interests are design and development of Microstrip power divider and combiner. She is member of IE (I).

Dr. S. Ravimaran, Principal and Professor in Computer Science and Engineering department of the M.A.M. College of Engineering, Tamil Nadu, India and he has received his B.E. in computer science and engineering from National Institute of Technology, Tiruchirappalli, India in 1997 and his M.E.

Computer science and engineering from Anna University, Chennai, Tamil Nadu, India in 2004. He has done his Ph.D. in Data and Transaction Management Using Surrogate Objects in Distributed Mobile Systems from Anna University Chennai, India in 2013. The Thesis was duly evaluated by the foreign and Indian examiners and both the examiners had unanimously recommended the *thesis* work as "Highly Commended". He has 24 years of experience in academics and research. He is an active member of computer society of India and holding the post of chairman – computer society of India, Tiruchirappalli chapter since April 2015. He has published 13 technical papers in national and international journals and currently he has guided 11 PhD scholars. His research interests are distributed System, cloud Mining, mobile Cloud and Utility mining.

Dr. M. Shanmugapriya has received her B.E in Electronics and Communication Engineering from Bharathidasan University, Trichirappalli, Tamil Nadu, India in 1996 and completed a Master Degree in Communication Systems from Anna University, Chennai, Tamil Nadu, India in 2005. She has done his Ph.D. in Design and development of miniaturized Antenna for WSN applications from Anna University Chennai, India in 2015. Now she is working as Professor in the department of Electronics and Communication Engineering, M.A.M. College of Engineering, Trichirappalli, Tamil Nadu, India. Her main research interests are design and development of Microstrip Antenna. She is member of IE (I).