

# Remote Training with Self-Assessment in Electrical Engineering

Zoja Raud, Valery Vodovozov

**Abstract**—The paper focuses on the distance laboratory organisation for training the electrical engineering staff and students in the fields of electrical drive and power electronics. To support online knowledge acquisition and professional enhancement, new challenges in remote education based on an active learning approach with self-assessment have been emerged by the authors. Following the literature review and explanation of the improved assessment methodology, the concept and technological basis of the labs arrangement are presented. To decrease the gap between the distance study of the up-to-date equipment and other educational activities in electrical engineering, the improvements in the following-up the learners' progress and feedback composition are introduced. An authoring methodology that helps to personalise knowledge acquisition and enlarge Web-based possibilities is described. Educational management based on self-assessment is discussed.

**Keywords**—Advanced training, active learning, distance learning, electrical engineering, remote laboratory, self-assessment.

## I. INTRODUCTION

THE specialists in electrical engineering are generally responsible for driving innovation and competition. Nowadays improvements in the industry sector, responses of enterprises to these novelties, as well as the progressive information and communication technologies pose a number of challenges to the staff [1], such as;

- lifelong learning the new professional tendencies and streams
- fast promotion of projects in the time restrictive conditions
- maintenance of electrical engineering systems using the Internet tools and resources
- increased knowledge and competency requirements

Companies expect from their engineers an intensive collaborative work, professional networking, concept generation, and decision-making, thus stimulating progress in educational environment, which gives all of these professionally-related skills.

Over the past decades, there has been increasing interest in effective remote learning technologies for continuous improvement of engineering level. To promote staff development, employees commonly attend online training courses, workshops, webinars, and conferences. With advancements in technology, universities and enterprises are engaging to introduce different educational media to teach students and enhance staff skills and knowledge. Additionally, advanced training on the workplace and situation-based

learning are increasingly penetrating to the contemporary engineering society. However, many studies and surveys [1]–[4] give evidence that the significant part of enterprises is restricted in participation in the staff training and vocational education. It was confirmed also by the authors' recent findings that companies are slow to implement new training approaches and the personnel does not benefit much from traditional courses because of their context of work, productivity and time limitations.

To recognize the best pathways to the regular and advanced training, the novel system of the professional profiles has been proposed in [2]. Using these profiles, company representatives may choose between multiple courses and learning institutions in searching the most appropriate for their specifics and targets. In [3], an overview of educational methodologies applied by universities and enterprises was also given and a set of attempts to enhance their effectiveness has been listed. With that end in view, instruction in industry can be divided between the formal training and the vocational one. The former approach covers enough broad areas with evidently defined topics and usually delivers certification whereas the latter one relates to training, which costs are supported by the company and the topics of which are related to individual jobs. Moreover, it has been presented [4] that, apart from the common working environment, staff training also takes place in some social events and in many everyday activities. Particularly, work is often carried out in the remote environment where employees collaborate and interact on specific subjects. Therefore, enterprises have an ability to integrate learning from economic, human, and social perspectives.

Competent equipment exploitation has always played an important role in all electrical, control and system engineers' activities. However, today industrial systems have become more and more complicated and, as a result, the demand for mastering the specialised and expensive equipment has increased. Nowadays, only respectable training and research centres may afford all the needed equipment for educational purposes, and even these institutions can only partially obtain what desire. In this connection, remote laboratories equipped with novel machines and devices represent a viable solution thanks to enlarged access to studying resources [5]. During the last years, some useful platforms have been developed and applied for distance teaching. The primary target of most such resources was to tackle issues related to hardware and software development for web-based instruction. Nevertheless, many other significant areas, including remote training methodology, were somewhat secondary. Since this

Z. Raud and V. Vodovozov are with Tallinn University of Technology, Ehitajate tee 5, Tallinn, 19086, Estonia (e-mail: zoja.raud@ttu.ee).

subject is still highly important for the qualification increase, new challenges in distance practice based on an active learning approach have been emerged by the authors. The research reported in this paper aims the following:

- to maintain high knowledge level of the students and staff in engineering by increasing the professional skill in power electronics, electrical and electronic experimentation
- to minimise the gap between remote mastering and other learning activities by improvement in the following-up the study of the professional equipment and feedback arrangement of learners' progress by creating an authoring methodology for personalisation of Web-based learning and professional improvement
- to enhance online self-assessment possibilities in a situation when a tutor cannot follow the trainee in the same manner as in the traditional workshop

The paper is organised as follows. After the literature review and explanation of the self-assessment methodology, the concept and basis of the training arrangement are stated. Next, it is shown how an active online learning methodology increases a comfort in sharing the knowledge between tutors and trainees. Then distance training management with self-assessment is described. In the conclusions, the results obtained are summarised.

## II. RELATED WORKS

As it was fairly shown in [6], [7], the demand for the use of online training instruments with simulators and remote equipment is currently prioritised in qualification enhancement of electrical, control and system engineers and engineering students.

The major criteria of the remote electrical installations needed for staff training were suggested in [8]–[10] where different approaches to Internet-based control of electrically driven machines have been shown. Nowadays the papers mainly concentrate on the discussion of the distance hardware and software that help the staff and trainers in appreciation the online methodology.

In literature, the problems and drawbacks of the remote resources are usually divided between technical and social spheres. In the former one, most authors, for example [11], [12], pay attention to the study of the fast physical phenomena because of difficulty in their online replication. On the other hand, consideration of the social aspect is crucial since traditional classroom contacts among tutors and trainees become complicated [13]. The same concerns the peer-to-peer interaction between the learning actors as well. In the classroom the learners and instructors can clarify doubts whereas in the remote environment such interaction is abated. Reduced social interplay was pointed in [14]–[16] as an important argument against the distance learning and advanced training.

In the majority of the traditional remote equipment the learners employ preliminary prepared tests and exercises with assigning the predefined input parameters [17]. They focus on the interactive cookbook-style tutorial aids and use them to

maintain equipment, produce measurements, filling data in the tables, and plotting the diagrams. Each student solves the similar problems and answers the same questions, often without any personal activity. Meanwhile, using such learning theory like constructivism [18] trainees might develop their knowledge by themselves successfully interacting with learning materials, objects, and actors within the curricula.

## III. LABORATORY ARRANGEMENT

A functional circuit of the laboratory designed in Tallinn University of Technology (TUT) for distance training in electrical drives and power electronics is presented in Fig. 1. The laboratory serves for two goals, namely, the onsite learning of TUT students and the distance advanced training of the foreign students and staffs for industrial enterprises. The remote facilities include educational equipment built on the basis of three groups of professionally designed stands. Here, the step drive and the servo drive computer-aided equipment from Festo accomplish the first group of setups whereas induction motor drives and power electronic converters from Lucas-Nülle arrange the second group.

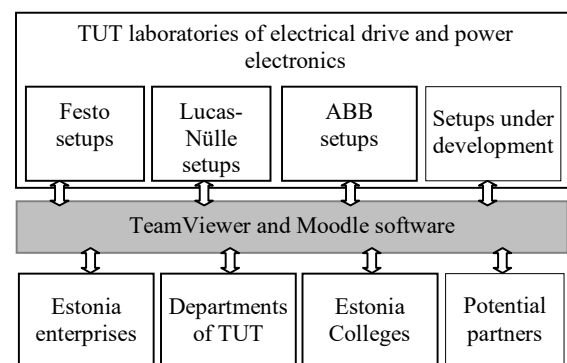

Fig. 1 Functional circuit of distance experimentation

The third group of setups is equipped with the set of original hardware-in-the-loop (HIL) simulators developed in TUT on the basis of ABB industrial equipment. This complex includes the pumping stand [19]; the electric auto and electric ship propulsion stand [20]. The general functional circuit of one of the developed HIL simulators is presented in Fig. 2. This setup incorporates two electrical drives of ACS800 series from ABB, namely the pump imitator and the pipeline imitator. Both have the similar structures consisting of induction motors, power converters, and remote consoles with housing, measuring, and cabling equipment.

The pump motor M2AA132S is of the nominal power 5.5 kW, voltage of 400 V, current of 11 A, torque of 36 Nm, and speed of 1450 rpm. The M2AA160L motor of the pipeline imitator has the power of 15 kW, voltage of 400 V, current of 29 A, torque of 98 Nm, and speed of 1460 rpm. The ACS800 converters provide the voltage variation from 0 to 415 V in the frequency range of 8 to 300 Hz and up to 75 kW capacities. Two main control modes of the motor drive are supported, namely, the scalar speed control at the constant voltage-frequency ratio and the direct torque control. To adjust

the pump drive imitator, the scalar mode is applied and to control the pipeline imitator, the direct torque control has been chosen.

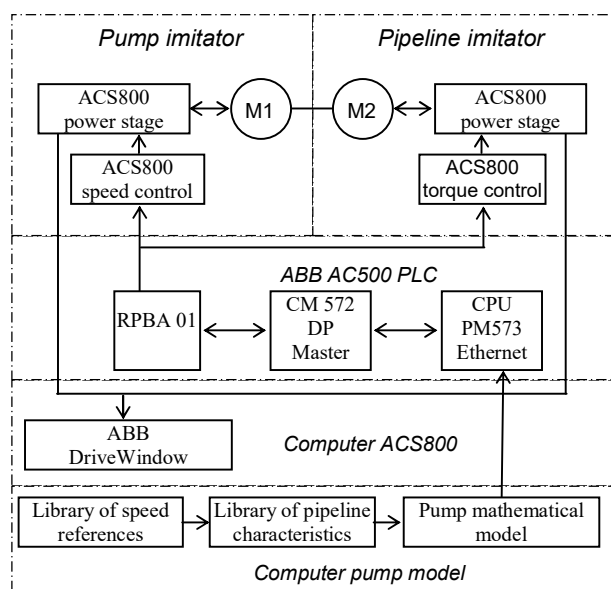

Fig. 2 HIL simulator of a pumping station

To support the online communication, the ACS800 are equipped with ABB DriveWindow model-based control and measurement software allowing the real-time parameter tracing and adjusting. DriveWindow provides the remote control of the pump and the pipeline imitators, their monitoring, graphical trending, tuning, and parameter registration. During the tests, the output data from the DriveWindow software related to the measuring parameters are recorded, displayed, and exported in graphical and numerical forms for the subsequent analysis. The pump model is communicated with the pump and pipeline imitators via the AC500 PLC consisting of the communication module CM572 DP, Profibus-DP Master module PM573, and Profibus DP adapter RPBA-01.

In the course of advanced training, the learners study equipment operation and maintenance procedures. They assign the desired pumping speeds and efficiency. In turn, the pipeline imitator is responsible for following the torque reference from the pump model to supply the required torque on the shaft thus permitting the drive running under all kinds of working conditions. This system takes the torque as a reference dependent on the shaft speed set by trainees. The ACS800 torque control system estimates the actual torque using the measured voltage and current signals and the built-in mathematical model. With the torque referred and actual values, the power converter manipulates the motor supply voltage supporting a fast dynamic torque response. Additionally, since the pipeline imitator is driven by the pump motor, just as a generator driven by a prime mover, electric power can feedback from the pipeline motor to its power stage, hence, electric energy may be either consumed or flied back to grid. In turn, an actual torque value of the pipeline

imitator can affect the speed reference of the pump imitator to change the speed at the load alternations. The appropriate controller is implemented in the frame of ACS500 PLC.

As a whole, the laboratory implies a significant decrease in cost and space for the equipment, air conditioning, illumination, consumed electricity, etc. compared to the establishment of the same laboratories in separate institutions. These costs drop in a distance scheme due to the fact that the training is conducted remotely. On the other hand, the number of learners in the laboratory grows as an access to the setups is open in non-working hours, including evening time and weekends prohibited at the traditional approach. This increases the resource utilization and attracts the students to make the laboratory works in these time slots.

#### IV. ACTIVE LEARNING MODE OF THE SKILL ACQUISITION

Starting from the year 2013, the students from different institutions took part in the distance learning. The first groups were from Virumaa College and Kuressaare College. Using the new educational approach, both groups successfully passed their laboratory sessions via Internet. Next, some groups from Estonian industrial enterprises have performed their advanced training.

During the last five years, an original learning environment has been prepared within the active learning context [21]. Our goal was to join the benefits of online experimentation with online learning activities that permit course participants to interact in a new fashion. Following this goal, the major method to increase student's activity in the skill acquisition and to suppress cheating was to apply the multi-variant multi-choice individual work and to increase the number of open problems where trainees could accomplish their own tasks. At that, the questions and tasks were randomly shuffled resulting in the great number of variants for experimentation. Along with this, the participants were supported with full access to the course materials in all the practical tasks that could be printed out prior to the experimentation. In addition, they could apply a lot of stimulus materials (simulations, animations, virtual experiments in the form of Java applets or flash objects, etc.) in their response generation and data analysing.

Currently, every distance training course incorporates five basic activities, namely: individual off-site preparation, collaborative on-site pre-work talk, per-variant experimentation, on-site summing-up discussion, and personal online reporting.

The first stage represents a virtual tour to ensure that the learners know the basic prerequisites and understand the specific hardware used. To this aim, a trainee has to answer some questions regarding the system performance. This part is conducted in a collaborative teamwork mode.

The most important part is the equipment study itself. In this stage, all participants are online connected with the testing equipment for remote control of the studied machines. The time required for this stage is very critical to allow all members handling their activities in turns. Each is responsible for implementation of his/her own duty, such as circuit

assembling, calculations, keeping the minutes and plotting the diagrams, etc. These duties change regularly therefore everybody learns to play all the roles.

To analyse the results and to draft the future report, after the labs implementation, the post-work discussion is employed in the collaborative manner as well.

#### V. SELF-ASSESSMENT IN DISTANCE LABORATORY PRACTICE

Progressive assessment is crucial in the learning outcomes understanding [22]. It should demonstrate whether the learners can apply, analyse, synthesise, remember, summarise, or evaluate skills from their practice. There exist a lot of difficulties in distance assessment [17], [22]–[26], mainly due to a problem of checking the person independence during the assessment procedure.

It is difficult to estimate whether the students can apply their knowledge and use it in the real engineering activity when the sole evaluation purpose is estimation of the students' ability to respond the questions stated in the form of credits and examinations [27]. It is the case when the assessment does not represent a part of the instruction process, but rather some scheduling event taking place at fixed times during the academic year. Meantime, the effectiveness of education and the overall study progress significantly depend on how the instructors understand the role of assessment, how strong it promotes learning, and how it influences on the subject the learners study and on the outcomes of their instruction. To stimulate the regular assessment, the students' evaluation is to be an integral part of everyday education activities without which the training process seems impossible [28], [29]. This is the reason why the evaluation methodology must be reformulated and redefined along with the learning process change thus helping a learner to receive the actual and useful feedbacks.

We consider the assessment methodology as an approach for overcoming the barrier between the theoretical knowledge and the practical work [30]. Unlike the traditional grading targeting to the learning process evaluation, an effort is made to transfer from estimation of learning towards an assessment aiming the learning improvement as recommended in [28], [31], [32].

The developed assessment model was first published in [33], [34] where we have chosen the formative role of mistakes to serve as the main driver for the student motivation. Next, our goal was to arrange the transition from the one-step grading process to continuous assessment. To this aim, we perform several iterations in the course time span by merging learning and evaluation into the common cycle. Our assessment procedures with a quick response and direct connection with the student's interest do not take place at some fixed instants during the semester but flow concurrently with the lessons. An evaluation built into the lectures, labs, and exercises uninterruptedly monitors the students' progress serving as a guideline of the learners' success. Thanks to such a point of view, assessment became a way of a feedback and reflection for instructors and staff in gauging questionable problems, finding unclear fields, and understanding how the

students follow their learning progress. It is substantially that the discussed approach changes the students' mind about the assessment as an educational instrument serving not just for examinations. By teaching and learning integration, an assessment serves now as a meaningful, authentic, and engaging pedagogical instrument the basic features of which relate to the students as the active participants in the assessment of their own activity and in the design of their reflective thinking [35].

Important benefits were obtained from the self-assessment procedures including automatically scoring answers on the questions concerning the labs preparation.

The process of students' competence self-assessment is conducted at all the stages of the laboratory session, including pre-work and post-work discussions, experiment conduction, and reporting. Each experiment involves both the mandatory and the optional items. The compulsory part assumes solution of only major problems whereas the other ones are optional. To obtain additional scores for self-assessment, participants and teams have to implement the optional points.

All the students' activities as well as the laboratory report are checked and, as soon as the learner completes the laboratory work, both his individual scores and the final grade are displayed. After reporting, the appropriate review options and the teacher's feedback help the student to understand whether his results are correct and how to further improve his skills. The report engine developed includes a suitable style for the result presentation. In the grade sheet published, all the laboratory participants can easily find the information for future reference.

To understand how the students perceive the work, the traditional conclusion section of the personal lab reports have been improved. There, the reporters are asked about ease of the laboratory access and the ability of the labs to clarify the concepts of the discipline. The students are asked also about their recommendations in stimulation their interest in experimentation as well as about mistakes in the methodology, circuits, tutorial aids, etc. Every fruitful advice is graded with additional score thus helping to enhance the future work and to improve teaching effectiveness. One useful peculiarity of the self-assessment approach is the deadline and cut-off time scheduling. It is prohibited to start the next lab while the previous work has not been reported, to start work in the case of coming late, as well as to acquire optional points behind the deadlines. This helps to support the learning discipline and increases the student's responsibility for each step and action.

#### VI. CONCLUSIONS

According to the first course evaluations, an active learning approach to advanced training via Internet received good marks from the trainees being graded between four and five, in average. The results of the lab reports, quizzes, and written final exams have shown high learners' activity. Analysis of these responses indicates a proper balance of the learning content in the trainee's minds.

Novel methodological resources for online studying of the laboratory electromechanical and electronic setups help to

develop such learner's habits like ability to effectively employ online software and hardware aiming to face the participants with real-world situations, interaction with peers in circumstances that require problem solving skills, and development of their close collaboration, initiative, and creativity. Additionally, the proposed active learning approach with a renewed self-assessment system based on interactivity and personalisation increases the learners' interest in the work and their learning motivation.

A self-assessment methodology in the scope of active learning electrical engineering promotes a development of theory appreciation, problem solving skills, effective circuit computation, experimentation experience, practical training, and acquisition of qualification. Analysis of students' participation in self-assessment, their lesson attendance, and final grades show that the proposed approach successfully contributes to the progress in the specialists' preparation.

The offered self-assessment system of the distance laboratory practice stimulates an evaluation of the students' procedural knowledge including applying the skills, answering "why and how" questions, result explaining, etc. It improves interacting with equipment and colleagues in a variety of paths. This focus is tailored to learners' engaging in development of such aspects like interdisciplinary context, discipline, pragmatic outcomes, and professional preferences for obtaining the most out of their education.

#### REFERENCES

- [1] V. Giannikopoulou, I. Hatzakis and A. Zafeiropoulos, "A technology enhanced flexible learning approach for SMEs," *18th IEEE International Symposium on Personal, Indoor and Mobile Radio Communications PIMRC 2007*, Athens, Greece, 2007, pp. 1 – 5.
- [2] L. Barreto, A. Vilaça and C. Viana, "NetStart – Achieving new abilities with ICT," *IEEE Technology and Engineering Education (ITEE)*, 4 (1), 2007, pp. 13 – 18.
- [3] V. Chang and C. Guetl, "E-Learning ecosystem (ELES) – A holistic approach for the development of more effective learning environment for small and medium sized enterprises," *Digital EcoSystems and Technologies Conference DEST 2007*, Cairns, Australia, 2007, pp. 420 – 425.
- [4] A. Cristea, A. Wentzler, E. Heuvelman and P. De Bra, "Adapting SME learning environments for adaptivity," *6th International Conference on Advanced Learning Technologies ICALT 2006*, Kerkrade, The Netherlands, 2006, pp. 130 – 132.
- [5] P. Piwek, "Supporting computing and technology distance learning students with developing argumentation skills," *4th IEEE International Conference EDUCON 2013*, Berlin, Germany, 2013, pp. 258 – 267.
- [6] E. Lindsay, S. Murray and B. D. Stumpers, "A toolkit for remote laboratory design & development," *First Global Online Laboratory Consortium Remote Laboratories Workshop*, Rapid City, SD, USA, 2011, pp. 1 – 7.
- [7] E. A. Mossin, L. C. Passarini and D. Brandão, "Networked control systems distance learning: state of art, tendencies and a new fieldbus remote laboratory proposal," *IEEE International Symposium on Industrial Electronics ISIE 2007*, Vigo, Spain, 2007, pp. 1870 – 1875.
- [8] A. Malek-Zadeh and H. Dietsch, "Web-based information technology for remote handling of electrical drives and control devices: An integrated approach," *International Conference on Networking, Systems, Mobile Communications and Learning Technologies ICN/ICONS/MCL 2006*, Morne, Mauritius, 2006, pp. 176 – 182.
- [9] K. Henke, S. Ostendorff, H. Wuttke and D. Simon, "Fields of applications for hybrid online labs," *10th International Conference on Remote Engineering and Virtual Instrumentation REV 2013*, Sydney, Australia, 2013, pp. 1 – 8.
- [10] J. Fraile-Ardanuy, P. Á. García-Gutiérrez, C. Gordillo-Iracheta and J. Maroto-Reques, "Development of an integrated virtual-remote lab for teaching induction motor starting methods," *IEEE Journal of Latin-American Learning Technologies*, 8 (2), 2013, pp. 77 – 81.
- [11] A. S. Araujo and A. M. Cardoso, "Pedagogical effectiveness of a remote lab for experimentation in Industrial Electronics," *3rd IEEE International Conference on E-Learning in Industrial Electronics, ICELIE 2009*, Porto, Portugal, 2009, pp. 104 – 108.
- [12] C. K. Maiti, S. Mahata and A. Maiti, "Design and development of a cost-effective online electronic circuits laboratory," *IEEE International Conference on Technology for Education, Chennai, India*, 2011, pp. 221 – 224.
- [13] G. Oriti, A. L. Julian and D. Zulaica, "Doubly fed induction machine drive distance learning laboratory for wind power and electric ship propulsion applications," *IEEE Energy Conversion Congress and Exposition ECCE 2011*, Phoenix, AZ, USA, 2011, pp. 1897 – 1903.
- [14] A. Rojko, D. Hercog and K. Jezernik, "Educational aspects of mechatronics control course design for collaborative remote laboratory," *13th Power Electronics and Motion Control Conference EPE-PEMC 2008*, Poznan, Poland, 2008, pp. 2349 – 2353.
- [15] S. Maarouf, M. Radhi, N. Vahe, D. A. Moustapha, S.-H. Hamadou, S. Sandra, O. Saber and B. Gerald, "Collaborative activities in the remote laboratory work," *15th International Conference on Interactive Collaborative Learning ICL 2012*, Villach, Austria, 2012, pp. 1 – 6.
- [16] P. Orduña, L. Rodríguez-Gil, I. Angulo, O. Dziabenko, D. Lopez-de-Ipina and J. Garcia-Zubia, "Exploring students' collaboration in remote laboratory infrastructures," *9th International Conference on Remote Engineering and Virtual Instrumentation REV 2012*, Bilbao, Spain, 2012, pp. 1 – 5.
- [17] I. Gustavsson, K. Nilsson, J. Zackrisson, J. Garcia-Zubia, U. Hernandez-Jayo, A. Nafalski, Z. Nedic, O. Gol, J. Machotka, M. I. Pettersson, T. Lago and L. Hkansson, "On objectives of instructional laboratories, individual assessment, and use of collaborative remote laboratories," *IEEE Transactions on Learning Technologies*, 2 (4), 2009, pp. 263 – 274.
- [18] Z. Raud, *Active Learning Technology in the Field of Electronics*. Saarbrücken, Germany: LAP Lambert Academic Publishing, 2014.
- [19] V. Vodovozov and I. Bakman, "Control of liquid density to prevent abnormal pumping performance," *7th WSEAS International Conference on Waste Management, Water Pollution, Air Pollution, Indoor Climate WWAI 2013*, Lemesos, Cyprus, 2013, pp. 217 – 222.
- [20] V. Vodovozov, Z. Raud and T. Lehtla, "A toolbox to design inverters for automotive applications," *11th WSEAS International Conference on Applications of Electrical Engineering AEE 2012*, Athens, Greece, 2012, pp. 190 – 195.
- [21] Z. Raud, V. Vodovozov. and T. Lehtla, "Educational thesaurus for learning electronics," *3rd WSEAS World Conference on Education and Educational Technologies WORLD-EDU 2012*, Athens, Greece, 2012, pp. 67 – 72.
- [22] C. Saul and H.-D. Wuttke, "Assessment 3.0 meets engineering sciences," *International Conference on Interactive Collaborative Learning ICL 2013*, Kazan, Russia, 2013, pp. 623 – 630.
- [23] S. T. Lundmark, A. Rabiei, T. Abdulahovic, S. Lundberg, T. Thiringer, M. Alatalo, E. A. Grunditz and C. Du-Bar, "Experiences from a distance course in electric drives including on-line labs and tutorials," *20th International Conference on Electrical Machines ICEM 2012*, Marseille, France, 2012, pp. 3050 – 3055.
- [24] A. M. Rashad, A. A. Youssif, R. A. Abdel-Ghafar and A. E. Labib, "E-assessment tool: A course assessment tool integrated into knowledge assessment," In: *Iskander, M. (Ed.), Innovative Techniques in Instruction Technology, e-Learning, e-Assessment, and Education*, New York: Springer, 2008, pp. 7 – 11.
- [25] H. Virolainen, "Digital portfolio as a learning tool," *The 7th International Conference on Education and Information Systems, Technologies and Applications EISTA 2009*, Orlando, Florida, 2009, pp. 248 – 252.
- [26] N. J. Powell, P. J. Hicks, W. S. Truscott, P. R. Green, A. R. Peaker, A. Renfrew and B. Canavan, "Four case studies of adapting enquiry-based learning (EBL) in electrical and electronic engineering," *International Journal of Electrical Engineering Education*, 45 (2), 2008, pp. 121 – 130.
- [27] Y. E. Woyessa, S. P. Van Tonder and D. Van Jaarsveldt, "Alternative student assessment in engineering education: Lecturers' perceptions and practices," *The 2nd International Multi-Conference on Engineering and Technological Innovation IMETI 2009*, Orlando, Florida, 2009, pp. 224 – 229.

- [28] H. Geysler, "Learning from assessment," In: *Gravett, S. and Geysler, H. (Eds), Teaching and Learning in Higher Education*, Pretoria: Van Schaik, 2004, pp. 90 – 109.
- [29] A. Raviv, "Academic skills: The key to meaningful learning in the higher education system – An action research conducted at Tel-Hai Academic College," *The 7th International Conference on Education and Information Systems, Technologies and Applications EISTA 2009*, Orlando, Florida, 2009, pp. 241 – 246.
- [30] Z. Raud, "Active learning power electronics: A new assessment methodology," *14th International Power Electronics and Motion Control Conference EPE-PEMC 2010*, Ohrid, Macedonia, 2010, pp. T14.1 – T14.5.
- [31] D. Rover, N. Santiago and M. M. Tsai, "Active learning in an electronic design automation course," *IEEE International Conference on Microelectronic Systems Education*, 1999, pp. 78 – 79.
- [32] J. F. Froyd and M. W. Ohland, "Integrated engineering curricula," *Journal of Engineering Education*, 1, 2005, pp. 147 – 164.
- [33] Z. Raud and V. Vodovozov, "Teaching, learning, and assessment in electronics using concept mapping technology," *1st WSEAS International Conference on Electronics and Electrical Engineering ELEL 2013*, Valencia, Spain, 2013, pp. 102 – 107.
- [34] V. Vodovozov, Z. Raud and L. Gevorkov, "Development of students' activity through on-lecture assessment in electrical engineering," *23rd IEEE International Symposium on Industrial Electronics ISIE 2014*, Istanbul, Turkey, 2014, pp. 2209 – 2213.
- [35] C. Savander-Ranne, O. Lunden and S. Kolari, "An alternative teaching method for electrical engineering courses," *IEEE Transactions on Education*, 51 (4), 2008, pp. 423 – 431.