

Influence of Driving Strategy on Power and Fuel Consumption of Lightweight PEM Fuel Cell Vehicle Powertrain

Suhadiyana Hanapi, Alhassan Salami Tijani, W. A. N Wan Mohamed

Abstract—In this paper, a prototype PEM fuel cell vehicle integrated with a 1 kW air-blowing proton exchange membrane fuel cell (PEMFC) stack as a main power sources has been developed for a lightweight cruising vehicle. The test vehicle is equipped with a PEM fuel cell system that provides electric power to a brushed DC motor. This vehicle was designed to compete with industrial lightweight vehicle with the target of consuming least amount of energy and high performance. Individual variations in driving style have a significant impact on vehicle energy efficiency and it is well established from the literature. The primary aim of this study was to assesses the power and fuel consumption of a hydrogen fuel cell vehicle operating at three difference driving technique (i.e. 25 km/h constant speed, 22-28 km/h speed range, 20-30 km/h speed range). The goal is to develop the best driving strategy to maximize performance and minimize fuel consumption for the vehicle system. The relationship between power demand and hydrogen consumption has also been discussed. All the techniques can be evaluated and compared on broadly similar terms. Automatic intelligent controller for driving prototype fuel cell vehicle on different obstacle while maintaining all systems at maximum efficiency was used. The result showed that 25 km/h constant speed was identified for optimal driving with less fuel consumption.

Keywords—Prototype fuel cell electric vehicles, energy efficient, control/driving technique, fuel economy.

I. INTRODUCTION

CONVENTIONAL energy and pollution are becoming the biggest problem around the world. Energy is one of the concerns of engineers out there trying to configure on how to generate power through several of techniques and applications. Therefore, novel renewable and clean energy power sources must be considered. One of the prevalent alternative sources of electric power is the fuel cell [1]. Fuel cells are devices that convert chemical energy directly into electrical energy without combustion. Proton Exchange Membrane (PEM) fuel cells have been considered as a replacement for the conventional internal combustion engine in automobile applications [1]. Automotive powertrain electrification can achieve low emission and high-energy efficiency to mitigate the energy shortage and air pollution brought by transportation sectors [2]. Research in fuel cell development, performances, and hybridization with application for vehicles has been taken seriously by many

institution especially automotive makers [3]. The Foundation for the Development of New Hydrogen Technologies in Aragon has developed a single seated fuel cell vehicle and successful achieve a maximum speed of 150 km/h [4]. The light electric vehicle (LEV) which powered by a 6 kW PEM fuel cell and able to run at a maximum speed of 60 km/h was developed by University of Tainan. Honda is one of the big automakers launching the FCX Clarity model that revolutionizes the automotive industry. The Toyota hydrogen fuel cell vehicles (FCV) start selling electric vehicles powered by hydrogen fuel cells by 2015. Specifically of the fuel cell vehicle developed is not limited, therefore many sectors are involved including military [5], public transportation [6], and recreation transportation [7]. PEM fuel cells have no advantages over the internal combustion engine at full load. Fuel cell system efficiency drop sharply at low power output because of balance of plants components such as blower and auxiliaries systems (i.e. fuel cell controller, DC/DC converters, motors, motor controller etc.).

To overcome the problem, optimization on powertrain of fuel cell vehicle need to be conduct to allow the fuel cell system operates more efficiently. Driving strategy methods are therefore being more considered in vehicle optimal designs [8] and controls [9] as well as infrastructure construction [10]. Driving conditions directly determine the energy consumption of on-road vehicles, and include driving speed, acceleration, idling time, etc. It is well established that individual variations in driving style have a significant impact on vehicle energy efficiency, whether this is the fuel economy of an internal combustion engine vehicle (ICE) or the allowable range of a hybrid or full battery electric vehicle (EV). Based on literature [11]-[16], the performance, fuel economy and emissions of vehicles depend on the way they are driven including driving distance and driving conditions. In [17]-[19], it was observed that driving parameters such as harshness of acceleration have an impact on the fuel economy and that changes to the driving behavior can significantly improve the vehicle energy consumption [20]. On the other hand, some recent studies of acceleration control of electric vehicle (EV), it was observed that adopting multiple accelerations during a speed change can reduce the energy consumption more than applying a constant acceleration value. Additionally, the power associated with accelerating an EV to a constant speed is generally much higher than the power associated with maintaining that constant speed [21]. Thus, it is very important to design a driving strategy by finding optimal acceleration value.

Suhadiyana Hanapi is with the Universiti Teknologi Mara, Uitm Shah Alam, Malaysia (e-mail: suhadiyanahanapi@yahoo.com).

The purpose of this research is to study the performance and fuel demands of a prototype PEM fuel cell vehicle undergoing different driving conditions. The types of driving techniques are also important since there is no need to accelerate every time. The driving conditions are changed rapidly and this varies with different topology. By conducting fixed amplitude speed range experiment, the vehicle can travel freewheeling and maybe can save a lot of energy and fuel. Energy efficiency identification and energy flow evaluation is a useful tool in identifying a detail performance of each component and sub-systems in a fuel cell vehicle system configuration.

II. METHODOLOGY

In this work, a lightweight prototype PEM fuel cell vehicle was used as the experimental target, which was combining a 1 kW air-blowing proton exchange membrane fuel cell (PEMFC) stack as a main source that provides electric power to a brushed DC motor. In order to characterize the behavior of PEM fuel cell vehicle system, it is necessary to understand its components and their functions. PEM fuel cell vehicles resemble normal gasoline or diesel-powered from the outside. Similar to electric vehicles (EVs), the vehicle use electricity to power a motor that propels the vehicle. Yet unlike the electric vehicles (EVs), which are powered by a battery, PEM fuel cell vehicles use electricity produced from on-board fuel cells to power the vehicle. The PEM fuel cell vehicle includes four major components such as fuel cell stack, hydrogen storage tank, electric motor and power control unit and DC/DC converter. All the components joint together in the system shows in Fig. 1 and the detail characteristics of the components illustrate in Table I.

A. Fuel Cell Stack

The fuel cell is an electrochemical device that produces electricity using hydrogen and oxygen. In simple terms, a fuel cell uses a catalyst to split hydrogen into protons and electrons, then the electrons travel through an external circuit. The hydrogen ions and electrons react with oxygen to

produces water. To obtain enough electricity to power vehicle; the individual fuel cells are combined in series to make a fuel cell stack. The overall cell reaction in a PEM fuel cell leads to the production of heat and water. The chemical reactions are given by (1)-(3).

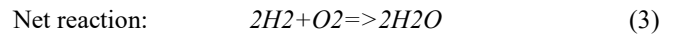
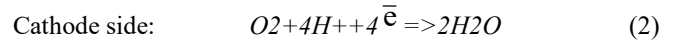
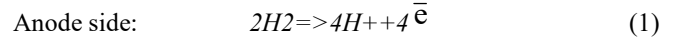

Theoretically, fuel cells have many advantages such as high efficiency and high power density; however have some weakness such as high sensitivity to load variations [22]. The stack efficiency directly related to the stack voltage by:

$$\eta_{stack} = \frac{v \cdot i}{mH_2 \cdot LHV \frac{m}{H_2}} = \frac{F}{\eta \cdot LHV \frac{m}{H_2}} \quad (4)$$

TABLE I
 SYSTEM PARAMETERS OF THE PEM FUEL CELL PROTOTYPE VEHICLE

Parameter	Value
<i>Vehicle</i>	
Size (m)	2.7 m x 0.6 m x 0.6 m
Vehicle mass + driver (kg)	104
<i>Fuel cell stack</i>	
No. of Cells	50
Nominal voltage (V)	30
Nominal power (W)	1000
Nominal current (A)	33.5
<i>DC Brushed Motor</i>	
Motor constant, K_m (Nm/A)	48
Supply voltage, V_s (V)	36
Armature resistance, R_a (Ω)	0.244
No load speed, N_o (rpm)	5680
No load current, I_o (A)	0.147

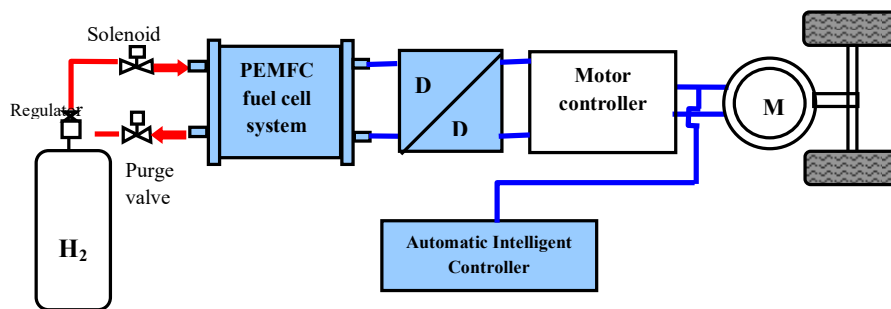

Fig. 1 A schematic diagram of the system configuration

where LHV is the lower heating value of hydrogen, V is the stack voltage, I is the stack current, mH_2 is the mass of hydrogen flow rate, F is Faraday constant and n is the cell number. This relation indicates that the higher stack voltage become the higher efficiency. However, the efficiency of the

stack decreases at very low power when the stack voltage is the highest point. Efficiency test for the stack show in Fig. 2 are conduct to ensure the efficiency point of fuel cell. Based on the experiment, the graph profile shows that the fuel cell efficiency is different for each load demand. The highest

efficiency of the fuel cell is at load 150 watt. The vehicle can maintain the best performance under this condition.

B. Hydrogen Storage Tank

The PEM fuel cell vehicles have a hydrogen storage tank. The hydrogen gas must be compressed at extremely high pressure to store enough fuel to obtain adequate driving range.

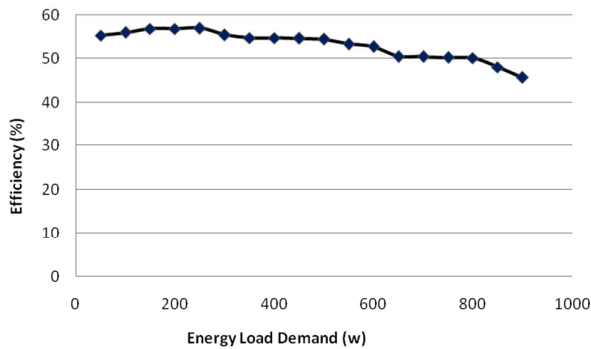

Fig. 2 Efficiency PEMFC Horizon 1000XP

C. DC/DC Converters

The component was interconnected between the fuel cell system and the external load brushed DC motor in order to rectify the variable stack voltage to the load required values.

D. Electric Motor and Power Control

The power control unit in the PEM fuel cell vehicle is governed by flow of electricity in the vehicle. By drawing power from battery or the fuel cell stack, it delivers electric power to the motor, which then uses the electricity to propel the vehicle. Maxon DC motor is choosing since efficiency of the motor is 94% (high enough compare with others manufacturer of dc motor). In order to ensure safe and correct power distribution during different stages such as start-up, normal operation and load variation, a central controller based on the Automatic Intelligent Controller. Usually, driver will control the acceleration and deceleration manually by increasing and decreasing the throttle. By increasing and decreasing manually, the possible where the driver maybe over accelerates during driving are usually occurs. General idea of automated intelligent controller is the driver just need to pushes one button only and then the system will run automatically until finishing line. The system runs at the speed range with the specific time given. Eagle-Tree data logger was used to coordinate all the components through efficient management as well as various parameter such as voltage, current, pressure and temperature of the system. The data acquisition (DAQ) unit was employed to monitoring and data collection. All the signals and operating parameters transmitted to software interface for real-time control and save in the personal computer (PC) for analysis purpose.

E. Modeling

In order to find the best acceleration, the dynamic behavior for prototype PEM fuel cell vehicle was designed. The knowledge about the physical and aspects of the vehicle

should know. The objective of the vehicle model is to predict the performance of the vehicle and understand the vehicle acceleration characteristic. The power train was designed by first evaluating the mechanical power needed by the car to run on the track. Then the best acceleration needed to minimize the energy demand, while maintaining maximum efficiency was simulated. The total tractive effort (F_{te}) can be determine from the sum of rolling resistance, F_{rr} , aerodynamic resistance, F_{ad} , climbing resistance, F_{hc} and acceleration resistance, F_{la} .

$$F_{te} = F_{rr} + F_{ad} + F_{la} + F_{hc} \quad (5)$$

In this study, assumption for hill climbing force is zero. All the forces are written in:

$$F_{te} = \mu_{rr}mg + \rho AC_d v^2 + ma + mgsin\theta \quad (6)$$

where μ_{rr} is rolling coefficient, A is vehicle frontal area, C_d is drag coefficient, m is vehicle mass, ρ is for air density, a is acceleration and $\sin \theta$ is a gradient. The following mechanical features of the prototype car were entered in the model shown as below:

- Drag coefficient, $C_d=0.062$
- Aerodynamic frontal area, $A=0.0016 \text{ m}^2$
- Mass, $m=104 \text{ kg}$
- Rolling coefficient of tire (manufacturer's data), $\mu_{rr}=0.0025$
- Traction wheel diameter, $r=0.2425 \text{ m}$

Fig. 3 shows the flat profile for the case study reference where the track consists 90° turns for every corner and the car needs to slow down for every turns. The vehicle run approximately on a flat road then the force due to climbing the hill can be neglected. The first phase of the race requires launching the car from rest. A mechanical model was used to assess the energy consumption and the corresponding traction power needed over a range of torques applied on the traction wheel to accelerate a car. The target speeds for the vehicle under average velocity of 25 km/h. For this study, to achieve the target speed, three driving techniques (i.e. 25 km/h constant speed, 22-28 km/h speed range, 20-30 km/h speed range) are embedded for the vehicle system.

III. RESULTS AND DISCUSSION

The lab tests were conducted for the three speed ranges. The vehicle was launched and accelerated until it reached the maximum speed in range. After that, the throttle pulled back until the vehicle decelerated to the minimum speed in the range. The experiment was conduct three times for each speed range to obtain accurate results. Since the average speed for each range is 25 km/h, the car distances go for each test is approximately same. For the 25 km/h constant speed, the time taken to accelerate or decelerate between the maximum and minimum speeds is less than other cases and the energy demand is lower than others are. The time to accelerate was set from 1 second to 355 seconds. Fig. 4 (a) shows the power

requirement needed the fuel cell to accelerate. Fuel cell power generation increase with vehicle speed due to the higher demands of the electrical motor high speeds. For the 25 km/h constant speed, the fuel cell needs approximately 210 watts of power to accelerate vehicle at the target speed. For the 20-30 km/h speed range, the fuel cell need more power compare to speed range at 22-28 km/h are 270 watts and 260 watts, respectively as shown in Figs. 4 (b) and (c). Fig. 5 presents the motor power requirement for each driving conditions. For the 20-30 km/h speed range (Fig. 5 (b)), the motor requires more energy because it must accelerate and decelerate within the range more frequently than other two cases. The idle time also reduced since the maximum speed is less than others. The 25 km/h constant speed is the best driving strategies to maintaining the system at maximum efficiency as shown in Fig. 5 (a). Moreover, the motor power needed less energy compared to others. From the experiment, the power demanded by the motor is 270 watts. Although the distance travelled and average speed (25 km/h) are the same, the total

power usage is different. Fuel consumption during the testing is recorded using hydrogen flow meter (before and after load is applied) and presented in Fig. 6. Theoretically, hydrogen consumption is a direct conversion of the electric current produced. In this case, the current is the load demand by the motor, which varies with the vehicle speed requirements. The results show that the measured hydrogen consumption closely follows the theory where the consumption increases linearly with the speed. For example, 9.98 litres per minutes of hydrogen is needed at 20-30 km/h speed range to accelerate the car at the speed target. The approach of using different driving strategies was found to be more effective in consuming less energy for the same acceleration duration and this concept was used to design the vehicle controller. Above this value, the energy consumption increases and fuel hydrogen also increases. This proves that an optimal driving strategy can be used to make a significant efficiency of the PEM fuel cell vehicle.

Open Science Index, Energy and Power Engineering Vol:10, No:1, 2016 publications.waset.org/10003195.pdf

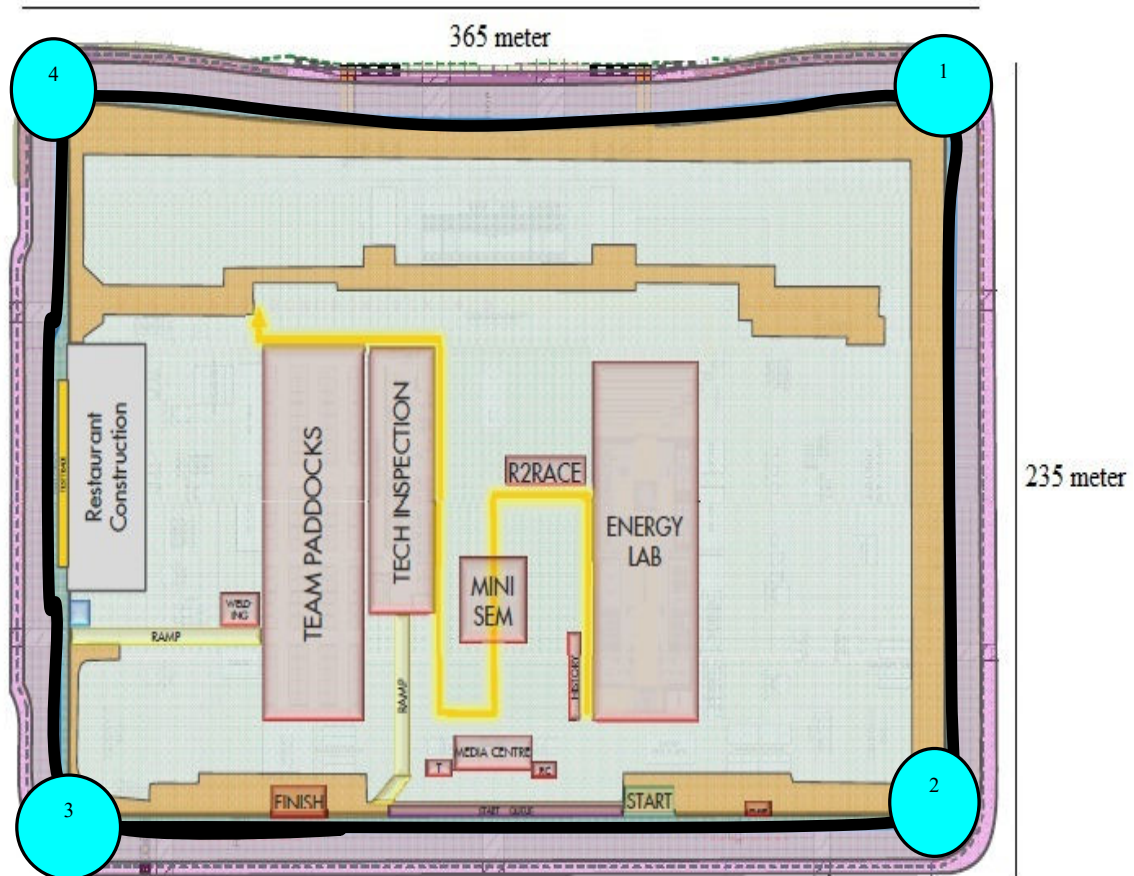
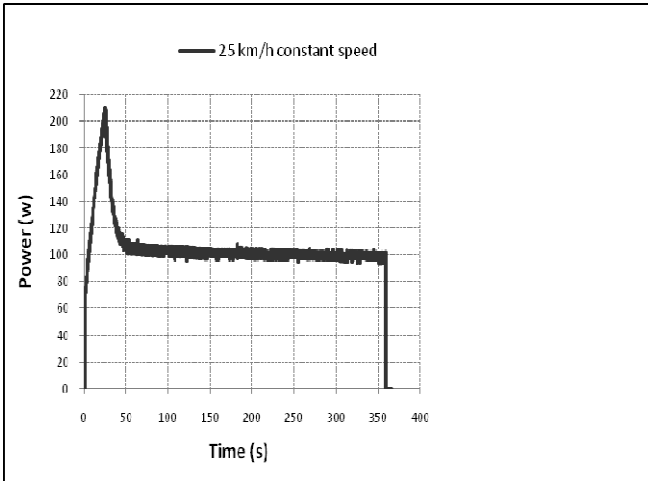
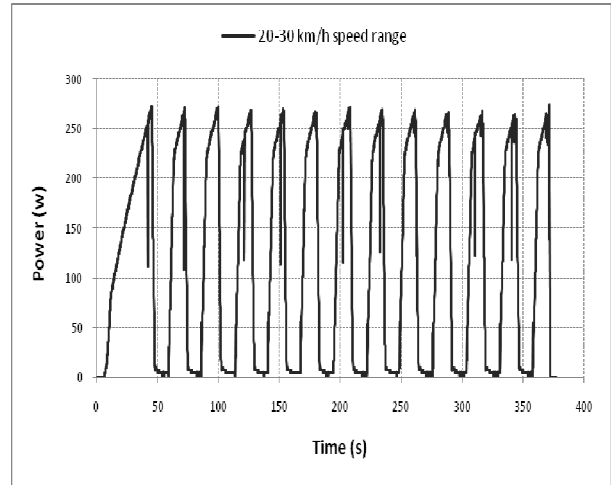

Fig. 3 Track Layout Luneta Park, Manila



(a)



(b)

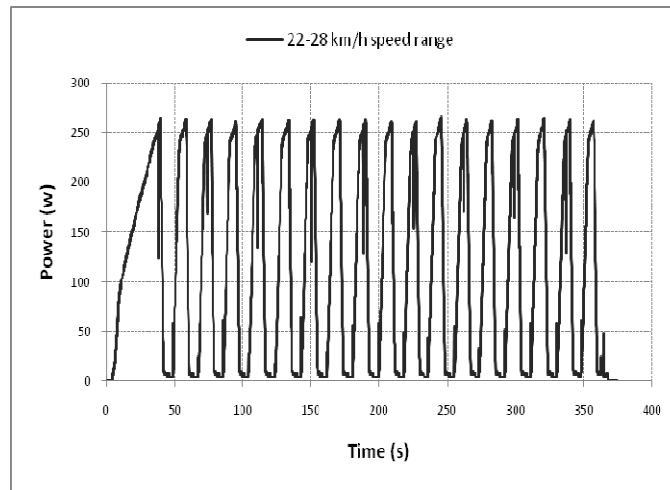

(c)

Fig. 4 Fuel cell power (a) 25 km/h constant speed (b) 20-30 km/h speed range (c) 22-28 km/h speed range

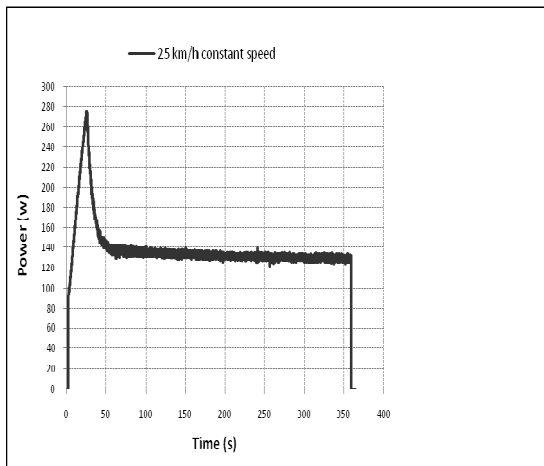

(a)

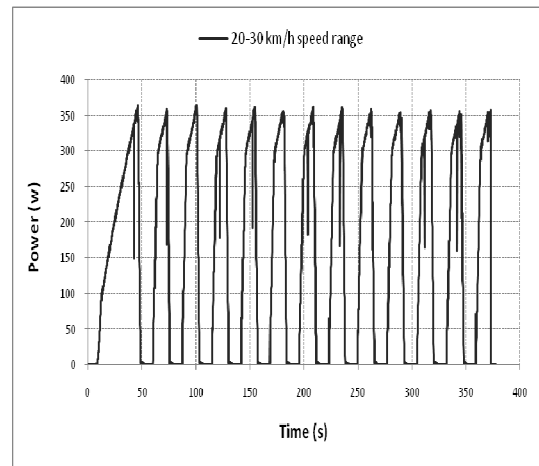

(b)

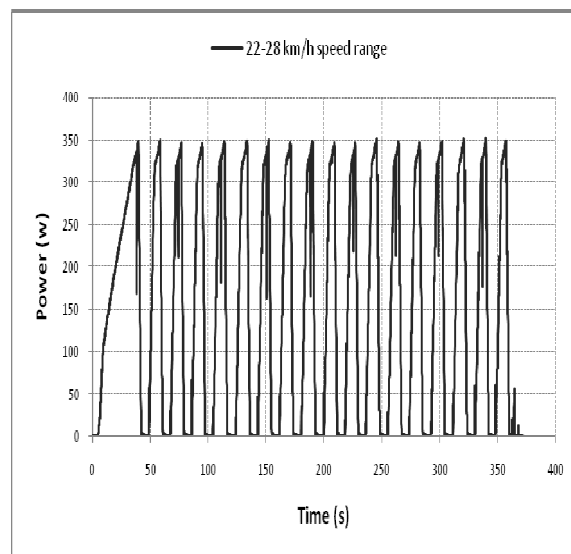

(c)

Fig. 5 Motor power (a) 25 km/h constant speed (b) 20-30 km/h speed range (c) 22-28 km/h speed range

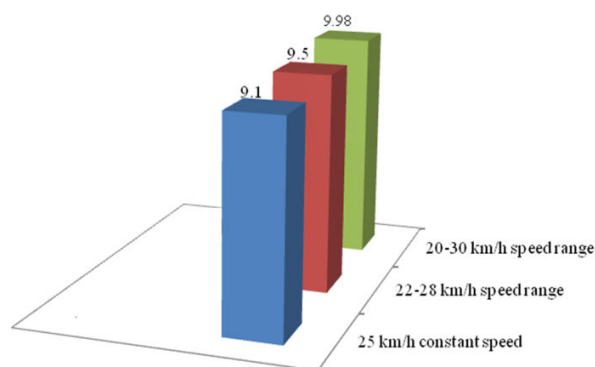

Fig. 6 Hydrogen consumption for three driving strategies (l/min)

IV. CONCLUSION

This paper presents a series of analysis to study and analyze the performance of a lightweight PEM fuel cell vehicle. A driving strategies is developed to minimize the total energy for a given distance and average velocity. This was done by determining an ideal velocity range through experimental test runs and modeling. The power consumption was calculated during acceleration (to the maximum speed) and power savings when the motor idles during deceleration (to the minimum speed). Based on this, 25 km/h constant speed was identified for optimal driving with less fuel consumption. Above this value, the energy consumption increases and fuel hydrogen also increases. The results of this study will be used to obtain the vehicle performance and embedded in the customized controller.

ACKNOWLEDGEMENT

The authors gratefully acknowledge the financial support given for this work by the Kementerian Pelajaran Malaysia (KPT) and thousands of thanks to Universiti Teknologi

MARA under the Faculty of Mechanical Engineering for this research development.

REFERENCES

- [1] Von Helmlolt R, Eberle U. Fuel cell vehicles: status 2007. *Journal of Power Sources* 2007; 165:833-43.
- [2] Wilbanks TJ, Greene DL. The importance of advancing technology to america's energy goals. *Energy Policy* 2010; 38(8).
- [3] Corbo P, Migliardini F, Veneri O. PEFC stacks as power sources for hybrid propulsion systems. *International Journal of Hydrogen Energy* 2009; 34: 4635-44.
- [4] Mora J, Romero L and Ruperez M. Formula zero: Development and kart's competition driven by PEM fuel cell. *Int. J. Hyg Energ* 2011; 36 8008-8016.
- [5] Jain M, Desai C, Kharm N, Williamson SS. Optimal powertrain component sizing of a fuel cell plug-in hybrid electric vehicle using multi-objective genetic algorithm. *IECON, Porto, Portugal*; 2009, November 3-5. p. 3741-6.
- [6] Ouyang M, Xu L, Li J, Lu L, Gao D, Xie Q. Performance comparison of two fuel cell hybrid buses with different powertrain and energy management strategies. *Journal of Power Sources* 2006; 163:467-79.
- [7] Thounthong P, Chunkag V, Sethakul P, Davat B, Hinaje M. Comparative study of fuel cell vehicle hybridization with battery or super capacitor storage device. *IEEE Trans Veh Technol* 2009; 58(8):3892-904.

- [8] Xu L, Ouyang M, Li J, et al. Optimal sizing of plug-in fuel cell electric vehicles using models of vehicle performance and system cost. *Appl Energy* 2013; 103:477–87.
- [9] Pearre NS, Kempton W, Guensler RL, et al. Electric vehicles: how much range is required for a day's driving? *Transport Res Part C: Emerg Technol* 2011; 19(6):1171–84.
- [10] Kelly JC, Macdonald JS, Keoleian GA. Time-dependent plug-in hybrid electric vehicle charging based on national driving patterns and demographics. *Appl Energy* 2012; 94:395–405.
- [11] Shiau, Ching-Shin Norman, Kaushal, Nikhil, Hendrickson, Chris T., Peterson, ScottB., Whitacre, JayF., Michalek, Jeremy J. Optimal plug-in hybrid electric vehicle design and allocation for minimum life cycle cost, petroleum consumption, and greenhouse gas emissions. *Journal of Mechanical Design* 2010; 132 091013—1 — 11.
- [12] Traut, E., Cherng, T.W., Hendrickson, C., Michalek, J. U.S. Residential Charging Potential for Plug-in Vehicles, Working Paper, Department of Mechanical Engineering 2013;, Carnegie Mellon University.
- [13] Kelly, J.C., MacDonald, J.S., Keoleian, G.A. Time-dependent plug-in hybrid electric vehicle charging based on national driving patterns and demographics. *Applied Energy* 2012; 94,395–40.
- [14] Neubauer, Brooker, Wood. Sensitivity of battery electric vehicle economics to drive patterns, vehicle range, and charge strategies. *Journal of Power Sources* 2012; 209, p269–277.
- [15] Neubauer, J., Brooker, A., Wood, E. Sensitivity of plug-in hybrid electric vehicle economics to drive patterns, electric range, energy management, and charge strategies. *Journal of Power Sources* 2013; in press.
- [16] Raykin, Leon, Mac Lean, Heather L., Roorda, Matthew J. Implications of driving patterns on well-to-wheels performance of plug-in hybrid electric vehicles. *Environmental Science and Technology* 2013; 46(11),p6363–6370.
- [17] C. Cheng, A. McGordon, J. Poxon, R. Jones, P. Jennings, A Model to Investigate the Effects of Driver Behaviour on Hybrid Vehicle Control. 25th World Battery, Hybrid, and Fuel Cell Electric Vehicle Symposium and Exhibition, November 5-9, 2010 (Shenzhen, China).
- [18] M. Knowles, H. Scott, D. Baglee, The effect of driving style on electric vehicle performance, economy, and perception, *Int. J. Electr. Hybrid Veh.* 4 (3) (2012) 228-247.
- [19] C. Bingham, C. Walsh, S. Carroll, Impact of driving characteristics on electric vehicle energy consumption and range, *IET Intell. Transp. Syst.* 6 (1) (2012) 29-35.
- [20] Fiat Eco: Drive, Eco-Driving Uncovered: the Benefits and Challenges of Eco- Driving based on the First Study using Real Journey Data, 2010. Available at: http://www.lowcvp.org.uk/assets/reports/Fiat_Eco-Driving%20Uncovered.pdf (accessed September 2015).
- [21] D.W. Gao, C. Mi, A. Emadi, Modeling and simulation of electric and hybrid vehicles, *Proc. IEEE* 95 (4) (2007) 729-745.
- [22] J. Larminie, "Electric Vehicle Technology Explained", John Wiley & Sons, Ltd, 2003.