

# Condition Monitoring for Controlling the Stability of the Rotating Machinery

A. Chellil, I. Gahlouz, S. Lecheb, A. Nour, S. Chellil, H. Mechakra, H. Kebir

**Abstract**—In this paper, the experimental study for the instability of a separator rotor is presented, under dynamic loading response in the harmonic analysis condition. The global measurement and analysis of vibration on the cement separator RC500 is carried, the points of measurement used are radial dots, vertical, horizontal and oblique. The measures of trends and spectral analysis for reconnaissance of the main anomalies, the main defects in the separator and manifestation, the results prove that the defects effect has a negative effect on the stability of the rotor. Experimentally the study of the rotor in transient system allowed to determine the vibratory responses due to the unbalances and various excitations.

**Keywords**—Rotor, experimental, defect, frequency, specter.

## I. INTRODUCTION

THE monitoring of rotating machinery vibration analysis have become an essential tool to detect faults and monitor their changes over time, which will project a predictive maintenance schedule. In order to improve the monitoring system and diagnostics of industrial equipment many researchers have worked on optimizing the vibration sensors. From regularly collected on rotating machine vibrations, vibration analysis is to detect any problems and follow their evolution in order to plan or postpone a mechanical intervention.

A rotating machine in operation generates the appearance of vibrations more or less variable. These vibrations can cause subsequent failures as they can be a result of earlier failures [1]. The extract vibration signal of a rotating machine is complex, the Fourier transform is a mathematical tool for decomposing the signals and represent sub amplitudes as a frequency spectrum [2]. The alternative methodology for conventional diagnostic techniques appeared during the past two years, to use an angular base instead of the classic time-based, and exploiting the angular position information. This methodology allows making the cyclo-stationary nature of rotating machines [3], [4]. Each fault has its own frequency component which distinguished from another and allows its detection easily on the spectrum. Out frequency signatures of different defects that can occur on a rotating machine have been defined [5], [6]. Interpret a peak on a spectrum therefore requires the identification of the kinematic and the various

constituent elements [7], [8]. This paper is worn on the use of vibration analysis for detection of various defects caused by the components of the separator, allowing to improve the sensitivity of certain indicators designed for this purpose and previously considered limited.

## II. SEPARATOR MONITORING

### A. The Objective Measurement

The vibration monitoring of an installation aims to:

- Check the evolution of the state of the plant in time.
- Conduct analysis of first level to the checks used in a conditional maintenance policy, you can:
  - Program a shutdown of a machine.
  - Assess the need for intervention at a date not provided in case of problems and possibly direct an analysis of the second level in case of serious or difficult problem.
  - Direct the maintenance operations before stopping.
  - Monitoring is carried out after a preliminary initiation in vibrational signature.

### B. Equipment Used

#### 1. Sensor (Accelerometer with Magnetic Base 100 mv / G)

One such type of sensor uses the accelerometer as this type provided greater benefits can be extracted acceleration, velocity and displacement simultaneously. This is a piezoelectric type accelerometer connected to MOVIOLOGII analyzer manifold.



Fig. 1 Accelerometer

#### 2. Data Collector (OneproD MVP-2C)

The apparatus used for this study is the (OneproD MVP-2C (Fig. 1), which is a portable vibration measuring battery operated and provided on a mobile.il use permits the overall measure of vibration parameter process, time signals and spectra, these measurements can be recorded on a special memory card.

A. Chellil, A. Nour, S. Chellil, H. Mechakra, S. Lecheb are with the Laboratory of Engines Dynamics and Vibroacoustics, University of Boumerdes, Algeria (e-mail: cchellil@yahoo.fr, umbb\_ldm@yahoo.fr, sami).

I. Gahlouz is with the Poly tech. Lille, LAGIS CNRS UMR 8219, 59655, Villeneuve d'Ascq cedex, France, France.

H. Kebir is with the Laboratory Roberval, University of Technology Compiègne, UTC, France.



Fig. 2 OneproD MVP-2C

*C. Work Description*

For the vibrational spectrums that will process one must follow the following steps:

- Collect data on PC (equipment technical data).
- Designation of measurement points on the way to the equipment on site.
- Measuring point programming on the software.
- Loading the route.
- Taking of vibration measurements on site.
- Unload the route collected by the analyzer on PC.
- Process data, and extract trends curves and spectra.
- In the end, we will interpret the results.

*D. The Thresholds of Judgment*

The outline of evolution of the vibrational amplitudes curves must be supplemented by comparison measurements with alarm and danger thresholds.

Quantification of these thresholds is very difficult and depends on many parameters, such as:

- Assembly (foundations, frame, bearings ...).
- Tolerance of the manufacturer.
- The experience of the machine.
- The needs of the user.

III. EXPERIMENTAL STUDY OF APPLICATION

This study includes the kinematics and frequency analysis of our equipment cement separator (Z2 S01).

*A. Measuring Points «Separator Z2-S01»*

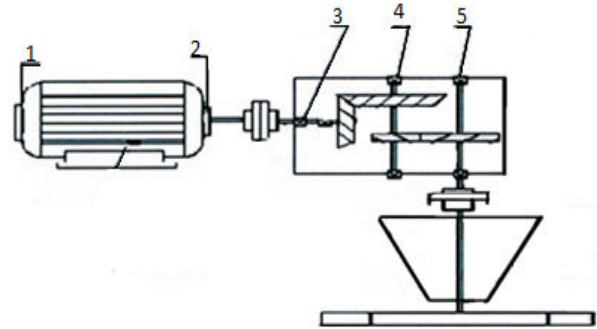

Fig. 3 Measuring points

We noticed that the vibration level by speed measurement in the bearings 02 and No. 03, in the alarm condition, requiring the intervention and the bearings 01 and No. 04 and 05 in alarm status but are acceptable and after the separator Z2 repair we noticed a reduction in the levels velocity and stabilization (correct state) in all bearings the trend curve and the spectrum defined defects in each measuring point.

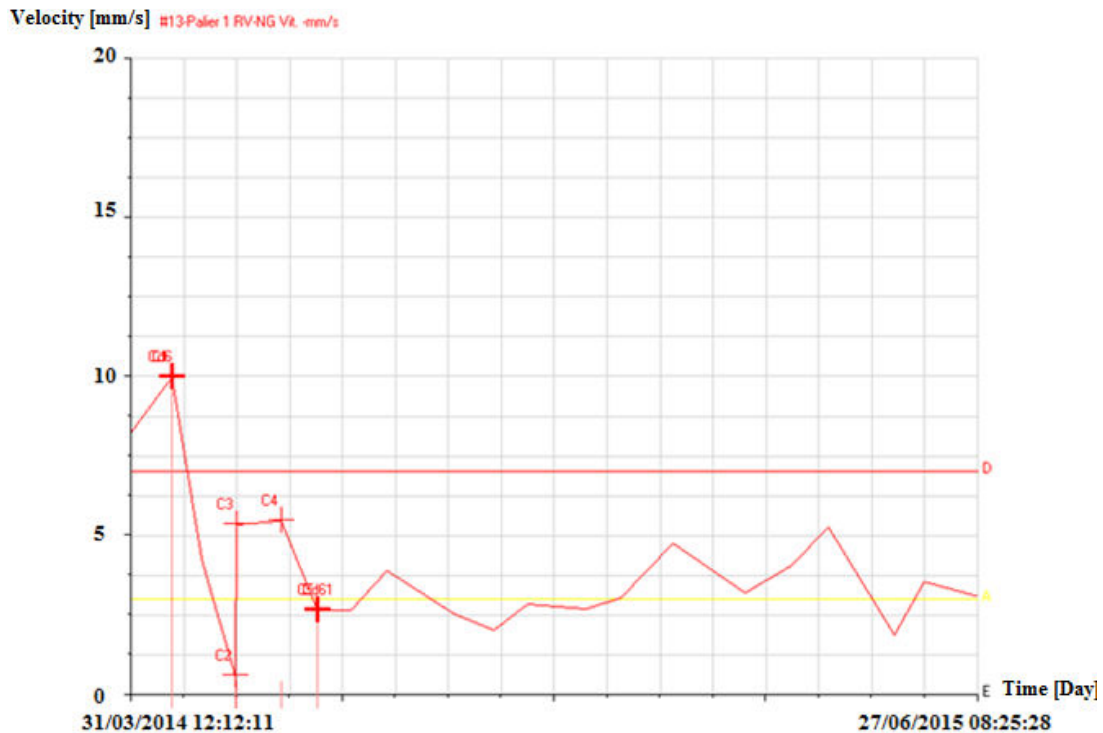

Fig. 4 Trend curve of bearing (01) RV-NG

*B. The Maximum Vibration Levels of the Machine*

TABLE I  
 MAXIMUM VIBRATION LEVELS OF THE MACHINE

Location of the measurement	bearing 01	bearing 02	bearing 03	bearing 04	bearing 05
vibration levels in 31.12.2011 (mm/s)	5.49	9.25	7.49	5.16	4.08
vibration levels in 02.03.2015 (mm/s)	2.79	2.98	2.33	1.71	1.86

Motor rotation speed of 31.12.2011: 825 r/min.  
 Motor rotation speed of 02.03.2015: 925 r/min.

*C. Analysis of Points of the Measures*

In this section, simulation can identify and indicate a set of modal analysis of the rotor to determine the eigenmodes and eigenfrequency.

The trend curve for the bearing N°01 (mm/s) is presented. There was an increase vibratory velocity level which exceeds the alarm threshold in point C4 (5.49 mm/s) which shows the presence of an anomaly, but we do not know their origin, after repair a speed decrease is observed with a reduction in (2.84 mm/s), for diagnosing the origin of the excess passes to spectral analysis.

The Specter of bearing N°01 (mm/s) is done in Fig. 5.

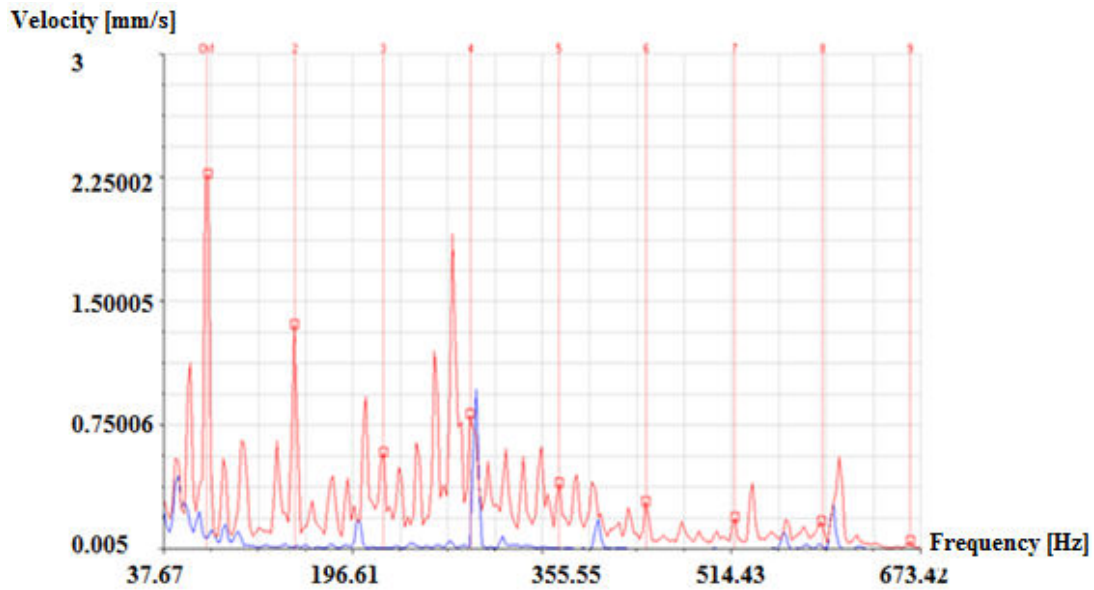

Fig. 5 Linear spectral image superimposed on bearing N°01 RV

■: spectrum before repair → net level rise in speed  
 ■: spectrum after repair → net improvement in speed level

The spectral signature represents a net increase of vibrational amplitude level of speed (red spectrum) in the medium frequency domain, corresponds to the frequency value equal to 73.05 Hz, this value corresponds at the same time to the frequency internal bearing ring, which shows a fault bearing inner ring. The recommendation is to change the bearing N°01.

After the repair performed (change bearing) we notice (blue spectrum) a net decrease in the speed level (the fault disappears), which confirms the accuracy of diagnosis.

Concerning the Bearing N°02, through the Trend curve we noticed a speed level of increase that exceeds the danger threshold Cd1 points (9.25 mm/s), indicating the presence of an anomaly but does not know their origin, this anomaly is more danger. According repair a speed decrease is observed with a reduction in (6.27 mm/s), for diagnosing the cause of the excess passes to spectral analysis. The spectrum N°02 (mm/s) is given in Fig. 6.

The spectral signature (red spectrum) represents a net increase in amplitude equal (7.51mm/s) in the low frequency

range corresponding to a frequency value equal to 27.41 Hz, this value corresponds to the 2nd harmonic of the rotation frequency of the motor shaft, which is a misalignment between the motor and reducer. The recommendation is the lineage of the line engine transmission – gearbox and the coupling change.

After the repair carried out (the coupling change) we notice (blue spectrum) a net decrease in the speed level (the fault disappears), which confirms the accuracy of diagnosis. The spectrum N°03 (mm/s) is given in Fig. 7.

The spectral signature (red spectrum) represents a net increase of amplitude in the medium frequency domain corresponds to a second frequency value that equals 250 Hz, this value corresponds to one of the first train of the gear meshing defect (pinion). The recommendation is changing the gearbox.

After the repair carried out (the gear change) we notice (blue spectrum) a net decrease in the speed level (the fault disappears), which confirms the accuracy of diagnosis.

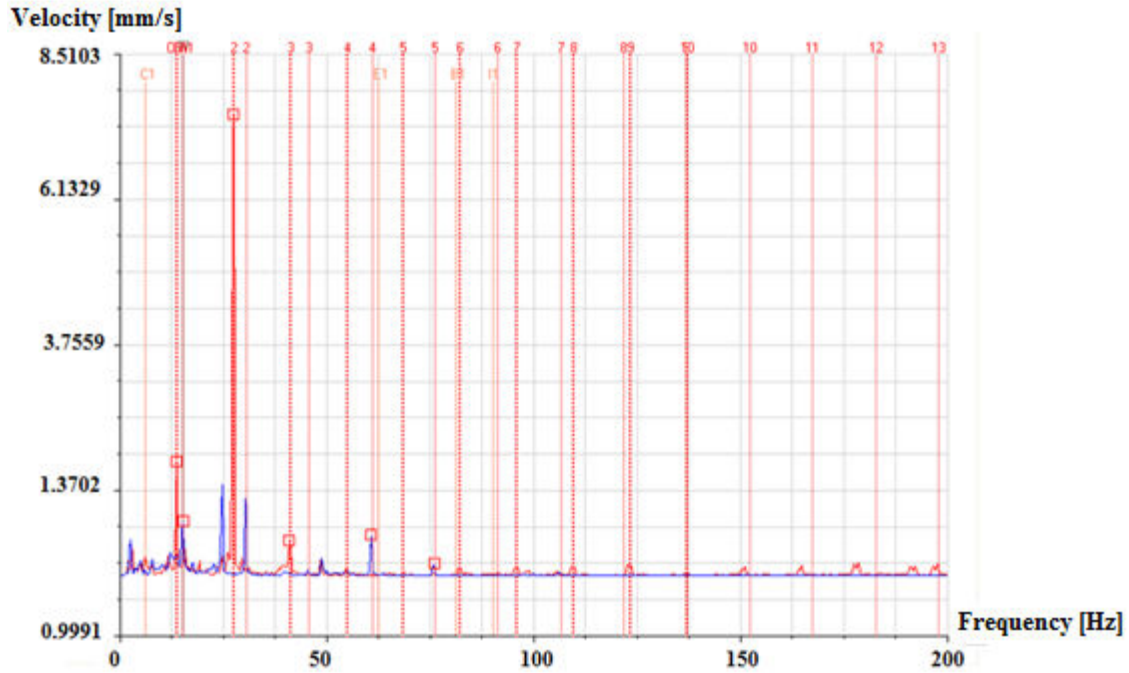

Fig. 6 Spectral Image superimposed on bearing N°02 RH

■: spectrum before repair N°03 RO  
 ■: spectrum after repair N°03 RO

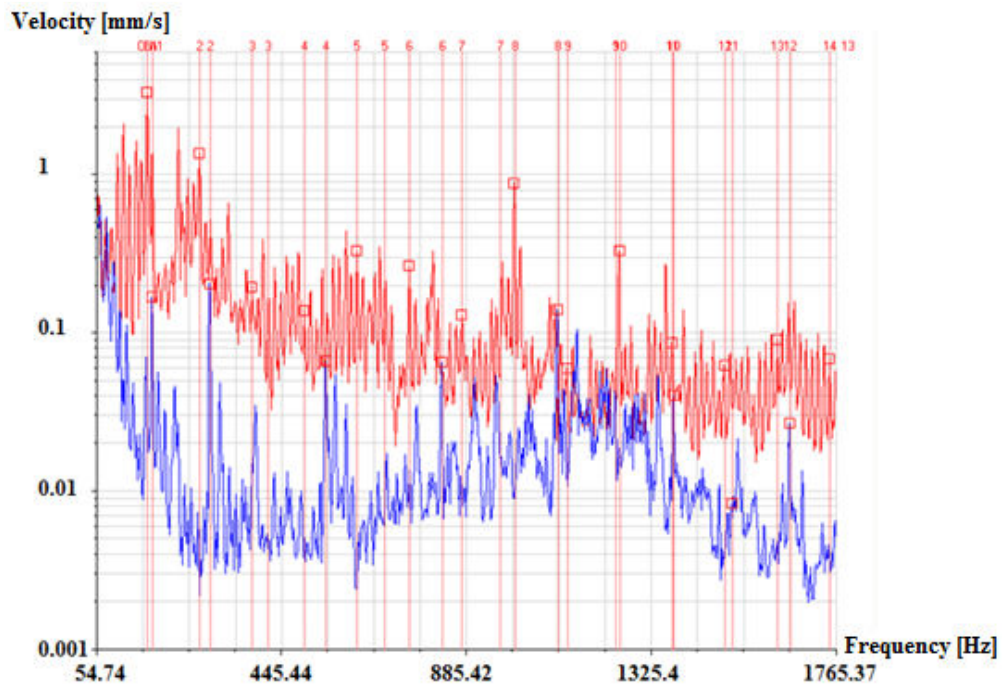

Fig. 7 Spectral Image superimposed on the logarithmic scale on bearing N°03 RO

■: spectrum before repair N°03 RO  
 ■: spectrum after repair N°03 RO

For the bearing N°04, According to the trend line oblique radial extent in remarks at point C2 (4.80 mm / s) an alarm threshold is exceeded, after repairing a decrease until Cd11 (1.86 mm/s), to diagnose original passes to frequency analysis.

The spectrum N°04 (mm/s) is given in Fig. 8. The spectral signature (red spectrum) represents a net increase of amplitude in the medium frequency domain corresponds to a frequency value equal to Ch1 = 70.15 Hz, this value corresponds to a discharge failure of the internal bearing ring.



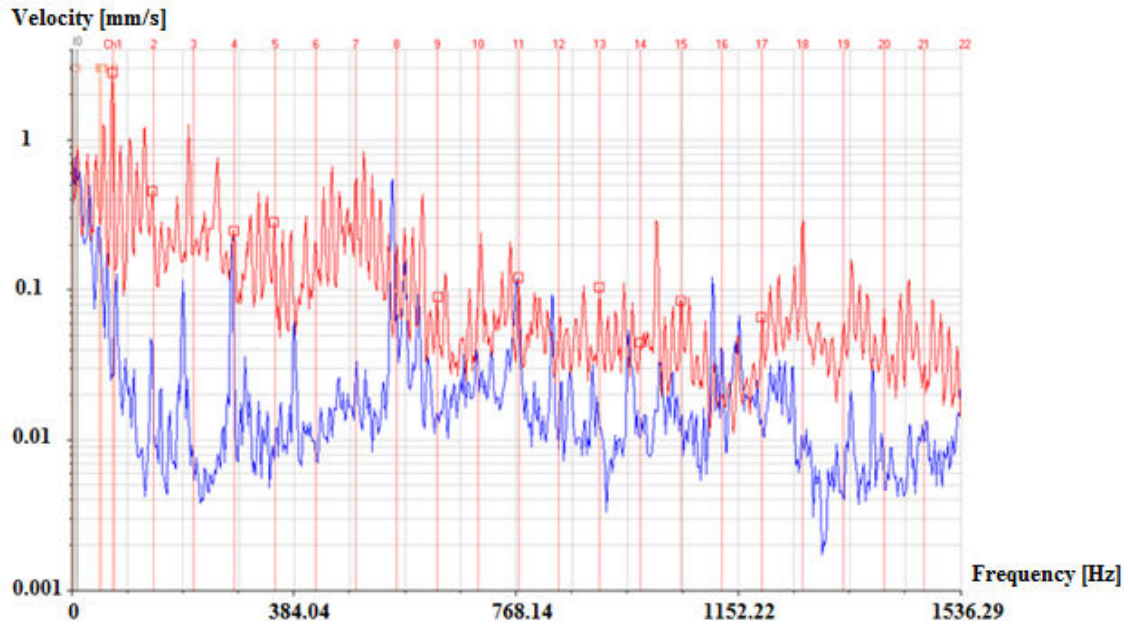

Fig. 8 Spectral Image logarithmic scale superimposed on bearing N°04 RO.

■: spectrum before repair N°04 RO  
 ■: spectrum after repair N°04 RO

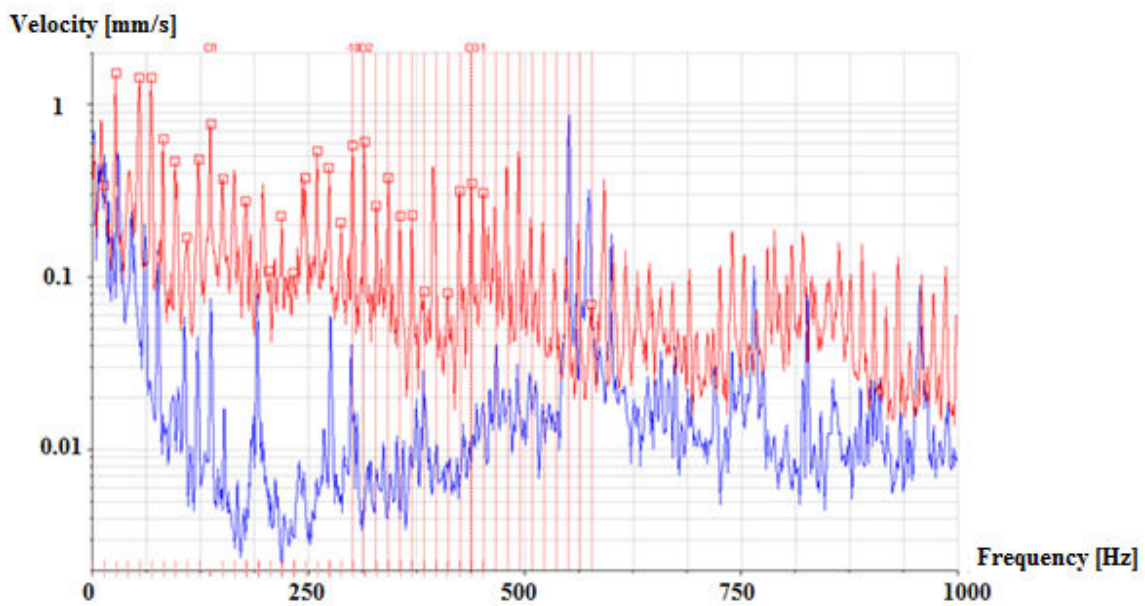

Fig. 9 Spectral Image superimposed on a logarithmic scale on bearing N°05 RO.

■: spectrum before repair N°04 RO  
 ■: spectrum after repair N°04 RO

The recommendations are changing the rolling bearing No 04. After the repair carried out (the gear change) we notice (blue spectrum) a net decrease in the speed level (the fault disappears), which confirms the accuracy of diagnosis.

For the bearing N°05, According to the oblique radial extent of the bearing 05, we note that the point C2 (4.08 mm / s) an alarm threshold is exceeded, after repair decreased to C3 (1.86 mm / s) is observed. The spectrum of bearing N°05 (mm/s) is given in Fig. 9.

The spectral signature (red spectrum) represents a net increase of the average amplitude in frequency domain corresponding to a shock to the frequency of rotation of the motor on the bearing supporting the shaft of the separator.

The recommendation is changing the rolling bearing No 05. After the repair performed (the change bearing and gearbox) we notice (blue spectrum) a net decrease in the speed level (the fault disappears), which confirms the accuracy of diagnosis.

#### IV. CONCLUSION

We found that the sets of knowledge about predictive maintenance by vibratory analysis expressed by a good use of the spectral analysis method and determination major defects our "RC500 cement separator" equipment.

Planning cement separator repair judgment concerning a larger gear defect that exceeds the danger threshold, the defect has influenced on the gearbox bearing, the gear change forced on us change the bearing to ensure a well-functioning despite defects in some levels are acceptable. According repair that resulted:

- The bearing fault on the motor shaft which is manifested primarily in low frequency in the vertical radial direction.
- Coupling fault which manifests itself by a misalignment between the motor and the gearbox in horizontal radial directions at low frequency.
- A gear on the pinion gear defect which occurs mainly in radial direction oblique average frequency.

#### REFERENCES

- [1] J. Morel. Surveillance vibratoire et maintenance prédictive. Techniques de l'ingénieur Comportement en service des systèmes et composants mécaniques, base docum. (bm5148) :0-21, 2005.
- [2] A. Djebala, N. Ouelaa, et N. Hamzaoui. Detection of rolling bearing defects using discrete wavelet analysis. *Meccanica*, 43(3) :339-348, Novembre 2007.
- [3] J. Antoni, J. Daniere, et F. Guillet. Effective vibration analysis of IC engines using cyclostationarity. Part IA methodology for condition monitoring. *Journal of Sound and Vibration*, 257 :815-837, 2002.
- [4] J. Antoni. Cyclostationarity by examples. *Mechanical Systems and Signal Processing*, 23(4) :987-1036, Mai 2009.
- [5] J. Morel, *Vibration des machines et diagnostic de leur état de fonctionnement*, Eyrolles, 1992.
- [6] K. Chinmaya et A.R. Mohanty, Monitoring gear vibrations through motor current signature analysis and wavelet transform, *Mechanical Systems and Signal Processing*, 20 (1) 2006, 158-187.
- [7] P.D. McFadden et J.D. Smith, Model for the vibration produced by a single point defect in a rolling element bearing, *Journal of Sound and Vibration*, 1984 96(1), 69-82.
- [8] P.D. McFadden et J.D. Smith, The vibration produced by multiple point defects in a rolling element bearing, *Journal of Sound and Vibration*, 1985 98(2), 263-73.