

Current Status of 5A LaB₆ Hollow Cathode Life Tests in Lanzhou Institute of Physics, China

Yanhui Jia, Ning Guo, Juan Li, Yunkui Sun, Wei Yang, Tianping Zhang, Lin Ma, Wei Meng, Hai Geng

Abstract—The current statuses of lifetime test of LaB₆ hollow cathode at the Lanzhou Institute of Physics (LIP), China, was described. 5A LaB₆ hollow cathode was design for LIPS-200 40mN Xenon ion thruster, and it could be used for LHT-100 80 mN Hall thruster, too. Life test of the discharge and neutralizer modes of LHC-5 hollow cathode were started in October 2011, and cumulative operation time reached 17,300 and 16,100 hours in April 2015, respectively. The life of cathode was designed more than 11,000 hours. Parameters of discharge and key structure dimensions were monitored in different stage of life test indicated that cathodes were health enough. The test will continue until the cathode cannot work or operation parameter is not in normally. The result of the endurance test of cathode demonstrated that the LaB₆ hollow cathode is satisfied for the required of thruster in life and performance.

Keywords—LaB₆, hollow cathode, thruster, lifetime test, electric propulsion.

I. INTRODUCTION

THE electric propulsion of space that utilize an electron discharge to ionize the propellant gas and create the plasma in the thruster require a cathode to emit the electrons. Cathode is electron sources which feature high electron emission capability and long life. It presents a single point failure because of the cathode fails to ignite and the thruster will not start up and operate [1].

The Lanzhou Institute of Physics (LIP) in China has been developed a 5A LaB₆ hollow cathode for LIPS-200 ion thruster [2] and LHT-100 Hall thruster which named LHC-5, the thrust of thruster is 40mN and 80mN respectively. Promising application of the LIPS-200 thruster that has been competed the space flight operation is attitude/orbit control of long-life geostationary satellites and deep space flight. The design life of LIPS-200 thruster is more than 15 years and accumulated operation time 11000 hours for orbit keeping of communication satellite. The lifetime test of LIPS-200 is nearly 7000 hours, which is developing in the TS-7 vacuum chamber in LIP, and the test is going on recently. Some cathodes were test in ground vacuum equipment, in order to supply the lifetime test of LIPS-200 and evaluate its life and reliability [3].

Life test of the discharge and neutralizer modes of LHC-5 hollow cathode were started in October 2011. This paper describes the current status of these tests.

Yanhui Jia, Juan Li, Yunkui Sun, Ning Guo, Tianping Zhang, Wei Meng, Hai Geng, Wei Yang, Lin Ma are with the Lanzhou Institute of Physics, Lanzhou, 730 000 China (phone: +86 0931 4585289; +86 0931 4585510; +86 0931 4585154; +86 0931 4585573, e-mail:jiayh510@163.com, leejuan-lip@foxmail.com, yunkui@qq.com, guoningaa@163.com, ztp@yahoo.cn, wmlanzhou@163.com, gengh88@163.com, weiyang83@qq.com, malinlpl@163.com).

II. EXPERIMENTAL ARRANGEMENT AND PROCEDURES

Two LHC-5 LaB₆ hollow cathodes were subjected to long life endurance test. The operation mode of one is main discharge and the other is ion beam neutralization. The following section describes the hollow cathode that has been tested, the test setup, procedures, parameters, and testing results.

A. The LaB₆ Hollow Cathode of LHC-5

The LHC-5 hollow cathode was design for main discharge cathode and neutralizer of LIPS-200 ion thruster, and the emitted current is 5A and 0.8A, respectively. Fig. 1 shows a schematic of the hollow cathode used in this study.

The cathode orifice plate was made from tantalum. This material was a low work function and sputter yield; it has a long history of use for hollow cathode orifice plate. The cathode insert was a cylindrical tube of polycrystalline LaB₆, compared to conventional impregnated dispensers, e.g. BaO-W 411, LaB₆ is the incredible robustness, high-current density, and long life. The LaB₆ cathode is insensitive to impurities and air exposures that can destroy a BaO dispenser cathode, which could withstand gas-feed impurity levels two orders of magnitude higher than dispenser cathodes at the same emission current density [4], [5]. The cathode tube was titanium, which was used because of its strength a high-temperature. A sheathed tantalum heater was wound and friction fit to the end of the cathode tube. Many wraps of 0.5mm thick tantalum foil were spot welded to the heater to serve as a radiation shield.

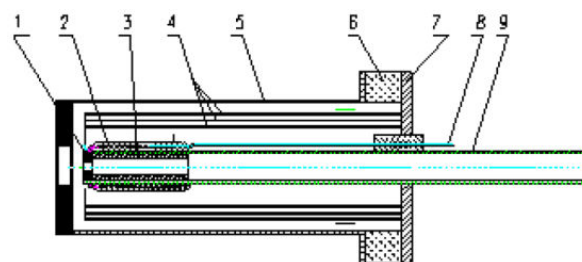

Fig. 1 The schematic of the hollow cathode; 1-the orifice plate, 2-heater, 3-LaB₆ insert, 4-thermal shield, 5-keeper, 6-isolator of ceramic, 7-mounted flange, 8- the cable of heater, 9-tube

B. Apparatus

A schematic of the test facility of TS-5 [6] is shown in Fig. 2. It consists of five basic components: vacuum chamber, vacuum pump system, flow system, control system and power supply. The main vacuum chamber is conducted within an 800mm inner diameter, 800mm long stainless steel. Four cathodes could be tested in the chamber at the same time. Base pressure

was on the order of 1.0×10^{-4} Pa as measured by an ion gauge. A low background pressure was necessary to preclude excessive oxidation of heater and cathode components which could result in inaccurate performance data and/or failure [7].

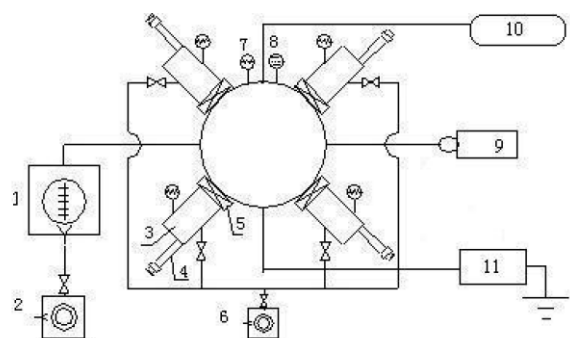

Fig. 2 Schematic of the Hollow Cathode Test Vacuum Facility; 1. 2X-15 Mechanical Pump 2. F250/1500 Molecular Pump 3. Subaltern chamber 4. Magnetic Driver 5. Valve 6. 2XZ-4 Mechanical Pump 7. Vacuum Gauge 8. Ionization Gauge 9. Xenon Bottle and Gas Flow Controller 10. Control System 11. Power Supply

C. Procedure and Parameters

Fig. 3 shows a schematic of the test apparatus. A computer data acquisition and control system are utilized for the testing. Currents and voltages are collected automatically at one-minute intervals by a data acquisition system, and these are measured and record in the test logs by manual every two hours. If an abnormal pressure detected, cathode operation is halted automatically. The tank pressure is maintained at approximately 2×10^{-3} Pa during the cathode operation. The cathode was secured to ceramic isolators that were mounted on a platform of vacuum chamber, as shown in Fig. 4.

The discharge current and cathode flow rate in the life test are almost identical to those in thruster operation. The discharge current and flow rate are 5.0A and 0.136mg/s Xenon for discharge cathode, and are 0.8A, 0.136 mg/s for neutralizer.

III. THE RESULT OF CURRENT STATUS

In this part, we will discuss the result of life test of cathode and neutralizer, respectively.

The variation of the discharge voltage in the life test is an important data for judge the cathode operation condition, which is shown in Fig. 5, and the value of voltage has been Non-dimensional treatment. Although the discharge voltage has been always in the design region. Its behavior is different during the test, especially the anode voltage. And an unexplained sharp rising of the anode voltage was occurred after 16,000 hours. We think that the reason of the voltage fluctuation is that the surface of insert might be polluted when the cathode was exposed in the air. The electron emitted surface condition was changed. And the ability of electron emitted would be return to a normal state after a short time because of the ion bombardment on the LaB6 surface. The keeper voltage has been fairly stable during the test.

The intentional and unexpected interruption has been occurred. The reasons for the interruptions were Xenon bottle

change, maintenance of equipment, and the measure of the structures parameter of cathode. Causes for the unexpected interruption were cool water leaking, central computer restated. All of the interruption will make the cathode exposition.

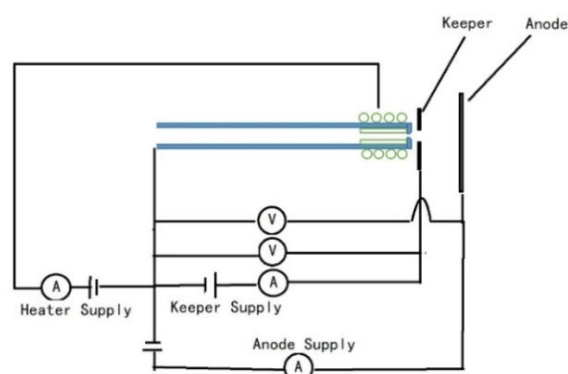

Fig. 3 Test apparatus for discharge cathode life test

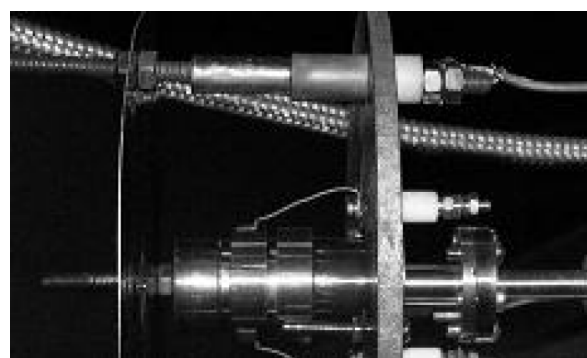

Fig. 4 The hollow cathode heater test platform

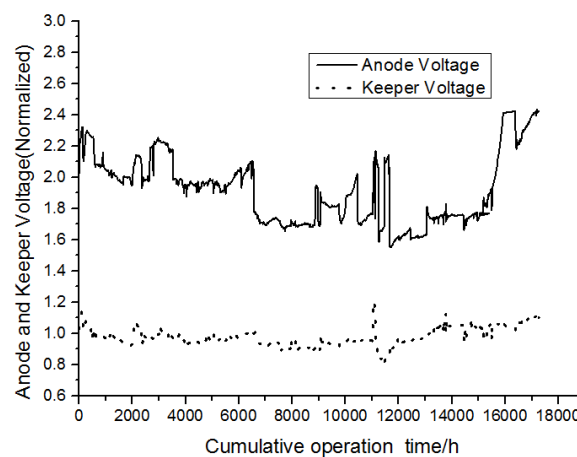

Fig. 5 The discharge voltage variation the during life time test

Close-up view of the downstream surface of the orifice plate in the life test is shown in Fig. 6. Microscopic observation was conducted many times during the life test. As shown in the figure, no remarkable signs of erosion can be observed on the orifice of the orifice plate, which can be demonstrated from the Fig. 7. Fig. 7 was shown that the cathode orifice diameter has not enlarged clearly. The orifice plate had a chamfer around the

orifice before the operation, however, it become unclear after 5430 hours operation or earlier. In addition, the surface looks rough after the operation compared with the initial surface. The reasons for that phenomenon have not clear, maybe because of ion-impingement, and detailed detection after the end of the life test might reveal them.

The test of neutralizer cathode was started with the discharge cathode at the same time. The cable and propellant injection connation are same as the discharge cathode.

The anode and keeper voltage during the test is shown in Fig. 8. The figure shows that the discharge voltage has increase before 1000 hour, and then has a slightly decrease, especially after 2000 hours the voltage slowed down remarkably. And the reason for this phenomenon is not clear, the author consider that the flow meter was failure during that time that was demonstrated by the last accuracy check. We think that the voltage increase after 11,000 hour due to the cathode deterioration.

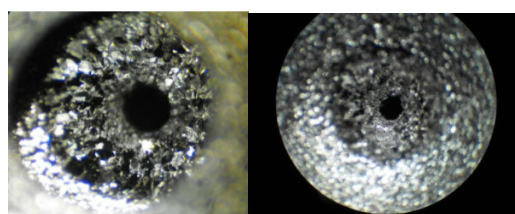

(a) 5430 hours (b) 6150 hours

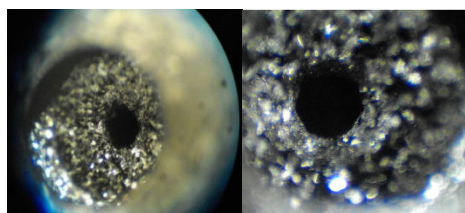

(c) 6750 hours (d) 8953 hours

Fig. 6 Close-up view of orifice plate during the life time test

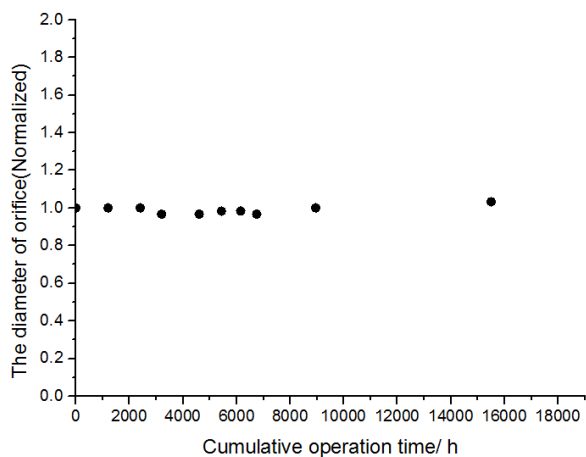

Fig. 7 The diameter of orifice versus operation time

Although some increase in the voltage has been observed, the life test of the neutralizer cathode continues without severe

problem at the present time. In addition, the voltage value is always in the design region. We can observe that the voltage has been almost constant until 12,000 hours. The neutralizer cathode is operating recently.

Microscopic views of the downstream surface of the neutralizer orifice plate in the life test are shown in Fig. 9. This figure indicated that there was some erosion on the chamfer surface of the tip, especially after, 8900 hours. The dimension of orifice versus with operation time is shown on Fig. 10. The figure was shown that the orifice diameter has slight increase during the test. After 15,500 hours, the diameter of the orifice become larger by approximately 6.7% compare with the initial condition.

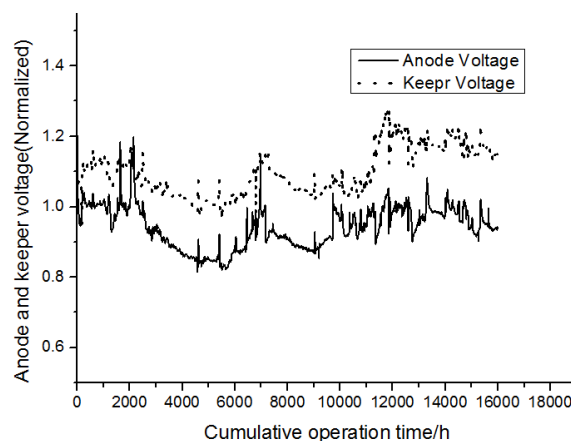
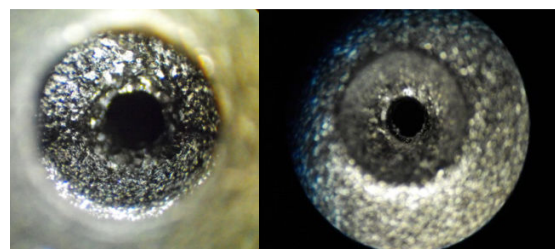
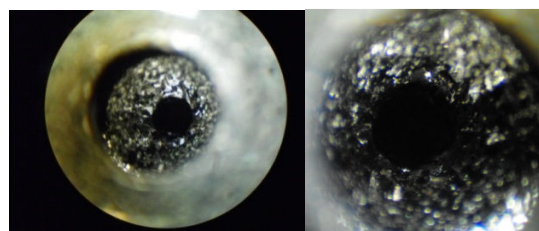

Fig. 8 The anode and keeper voltage variation the during life time test



(a) after 5478 hours (b) after 6200 hours



(c) after 6750 hours (d) after 8908 hours

Fig. 9 Close-up view of the neutralizer orifice plate during the life time test

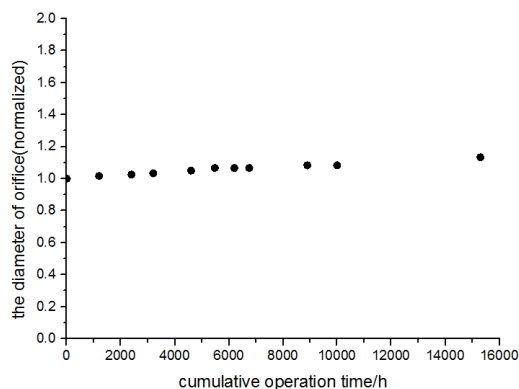

Fig. 10 The diameter of neutralizer orifice versus operation time

IV. CONCLUSION

Lifetime test of LHC-5 LaB6 hollow cathode (and neutralizer) design for LIPS-200 ion thruster and LHT-100 Hall thruster are being conducted. In the life test of the discharge cathode, the cumulated operation time reached 17,300 hours in April 2015. Some increase in the discharge voltage has been emerged, but it just in the designed value region at present time. The observation has shown that the orifice diameter has slightly changes, which will affect the cathode performance directly. The life test of the neutralizer has accumulated 16,100 hours until April 2015.

Both cathode and neutralizer have demonstrated high durability. The lifetime test result has shown that the LHC-5 LaB6 cathode could be sufficient for the communication satellite. The experiment would go on until the cathode failure or one of operation parameter does not in the region of designed.

ACKNOWLEDGMENT

The authors would like to acknowledge the experimenter Cheng Rong, He Fei, Luo junhua, Liu Xingwang, Zhang Peng, Zhao Zhen, et al.

REFERENCES

- [1] Tighe, W. G., Freick, K. and Chien, K.R., "Performance Evaluation and Life Test of the XIPS Hollow Cathode Heater," AIAA 2005-4066, July 2005.
- [2] T.P Zhang, X.Y. Wang, H.C. Jiang, "Initial Flight Test Results of the LIPS-200 Electric Propulsion System on SJ-9A Satellite," IEPC 2013-47, October 2013.
- [3] Y.H. Jia, N. Gou. "The reliability evaluation of LHC-5 hollow cathode heater," IEPC 2013-47, October 2013.
- [4] Goebel, D. M., Watkins, R. M. and Jameson, K. K., "LaB6 Hollow Cathodes for Ion and Hall Thrusters," Journal of Propulsion and Power, vol. 23, no. 3, pp.552-558, 2007.
- [5] D.M.Goebel, I.Katz. "Fundamentals of Electric Propulsion : Ion and Hall Thrusters," JPL Space Science and Technology Series. March 2008.
- [6] Guo, N., "Research of hollow Cathode for Ion thruster," Ph.D Dissertation, China Academy of Space Technology, Lanzhou, 2008.(In Chinese)
- [7] Soulas, G.C., "Status of Hollow Cathode Heater Development for the Space Station Plasma Contactor," AIAA 1994-3309, June 1994.