

Pose-Dependency of Machine Tool Structures: Appearance, Consequences, and Challenges for Lightweight Large-Scale Machines

S. Apprich, F. Wulle, A. Lechler, A. Pott, A. Verl

I. INTRODUCTION

Abstract—Large-scale machine tools for the manufacturing of large work pieces, e.g. blades, casings or gears for wind turbines, feature pose-dependent dynamic behavior. Small structural damping coefficients lead to long decay times for structural vibrations that have negative impacts on the production process. Typically, these vibrations are handled by increasing the stiffness of the structure by adding mass. This is counterproductive to the needs of sustainable manufacturing as it leads to higher resource consumption both in material and in energy. Recent research activities have led to higher resource efficiency by radical mass reduction that is based on control-integrated active vibration avoidance and damping methods. These control methods depend on information describing the dynamic behavior of the controlled machine tools in order to tune the avoidance or reduction method parameters according to the current state of the machine.

This paper presents the appearance, consequences and challenges of the pose-dependent dynamic behavior of lightweight large-scale machine tool structures in production. It starts with the theoretical introduction of the challenges of lightweight machine tool structures resulting from reduced stiffness. The statement of the pose-dependent dynamic behavior is corroborated by the results of the experimental modal analysis of a lightweight test structure. Afterwards, the consequences of the pose-dependent dynamic behavior of lightweight machine tool structures for the use of active control and vibration reduction methods are explained. Based on the state of the art of pose-dependent dynamic machine tool models and the modal investigation of an FE-model of the lightweight test structure, the criteria for a pose-dependent model for use in vibration reduction are derived. The description of the approach for a general pose-dependent model of the dynamic behavior of large lightweight machine tools that provides the necessary input to the aforementioned vibration avoidance and reduction methods to properly tackle machine vibrations is the outlook of the paper.

Keywords—Dynamic behavior, lightweight, machine tool, pose-dependency.

S. Apprich is with the Institute for Control Engineering of Machine Tools and Manufacturing Units, University of Stuttgart, Stuttgart, 70174 Germany (phone: 0049 (0)711 685-84626; fax: 0049 (0)711 685-74626; e-mail: Stefanie.Apprich@isw.uni-stuttgart.de).

F. Wulle is with the University of Stuttgart, Stuttgart, 70174 Germany (e-mail: Frederik.Wulle@web.de)

A. Lechler is with the Institute for Control Engineering of Machine Tools and Manufacturing Units, University of Stuttgart, Stuttgart, 70174 Germany (e-mail: Armin.Lechler@isw.uni-stuttgart.de).

A. Verl is member of the Executive Board of Fraunhofer research organization, Munich, Germany.

THE common phenomenon of the pose-dependent dynamic behavior of industrial robots within their working space has become established. For the new field of machining with industrial robots, the pose-dependency of robots has been investigated and considered in [1], [2]. Machine tools, especially large ones, show pose-dependent dynamic behavior over the working space as well. However, so far, this phenomenon has not been in the focus of consideration as common machine tools are constructed very massively and stiffly [3], [4]. Furthermore, feed drive controls are designed regarding the dynamical worst case. Hence, they are considering the most disadvantageous pose and thereby the lowest eigenfrequency of the machine tool. Two trends permit this approach no longer – on one hand, the general goal of increasing the resource efficiency of machine tools and, on the other hand, the enlargement of machine tools for the production of large parts, e.g. for the wind energy or the transport sector [5]. Concerning traditional machine tool designs, the larger the machine tool structure gets, the more construction material is necessary to guarantee static and dynamic stiffness. And the heavier the moved machine parts are, the more power and mass the feed drives need. This leads to an increasing consumption of resources like e.g. energy, rare earths and construction material. Furthermore, using common feed drives, a maximum of the possible dynamics in combination with the mass of the moved parts is reached at a certain point and cannot be increased arbitrarily [5]. These facts result in the necessity of lightweight construction of machine tools - at least of large ones. Actually, there are no constructive solutions to reduce the mass of large machine tool structures considerably and maintain the dynamic stiffness like in a massively constructed machine tool. So, the deficits in the dynamic stiffness of large lightweight machine tools must be compensated by control strategies. Commonly used cascade controls alone are not sufficient to meet this challenge. Instead, additional active vibration reduction or advanced control strategies need to be applied, which consider the pose-dependent dynamical behavior of a lightweight large-scale machine tool. However, this implies that the pose-dependent machine dynamics have to be investigated and mathematically described.

For guaranteeing accurate machining, active stiffness provided by active vibration reduction and control strategies have to be ensured. However, this requires that the dynamic machine tool behavior for the actual pose and machining

condition is exactly known, which, in turn, presents a major challenge.

The objective of this paper is to present the appearance, consequences and challenges of the pose-dependent dynamic behavior of lightweight large-scale machine tool structures in production. Therefore, starting from theoretical investigations on the reduced dynamical stiffness of lightweight machine tool structures, the appearance of the pose-dependent dynamical behavior is shown in Section II. Section III describes the results of the experimental modal analysis of a lightweight machine tool test structure. Section IV gives an overview on common vibration reduction methods and shows exemplarily the consequences of inaccurate dynamical machine tool models for the efficiency of vibration reduction strategies. Section V summarizes the state of the art of pose-dependent dynamical machine tool models. On basis of the discussion of Section V and the FE-model of the investigated test structure of Section III, the main criteria for a pose-dependent dynamic machine tool model are derived in Section VI. The paper ends with the outlook on a possible approach for a pose-dependent dynamic machine model for active vibration reduction and control strategies, which fulfills the mentioned criteria.

II. THE CHALLENGE OF USING LIGHTWEIGHT STRUCTURES IN MACHINE TOOLS

For machine tools consisting of lightweight structures it is a challenge to enable proper machining conditions. This is due to the reduced stiffness and the pose-dependency of the machine tool's eigenfrequencies. The reduced dynamical stiffness of a lightweight structure causes lower critical eigenfrequencies and higher vibration amplitudes.

Fig. 1, subplot 1 shows the example of a gantry type machine tool with a moveable processing head (e.g. laser, printer and machining spindle) at the cross beam. The beam model in subplot 2 (Fig. 1) exemplarily represents the cross beam of the gantry type machine tool. The maximum displacement $x(l_x)$ of the beam can be computed at the location l_x with the equation in [6]:

$$x(l_x) = \frac{Fa^2b^2}{3EI} \quad (1)$$

F is the weight of the processing head, l is the length of the beam, a and b are lengths to describe the position of F , E is the Young's Modulus and I the geometrical moment of inertia.

In order to reduce the moving mass it is advisable to reduce the mass of the cross beam. For a mass reduction far in excess of the actual possibilities, e.g. by topology optimization, it is suitable to change the design. A panel construction with a changed beam cross section (Fig. 1, subplot 3), an alternative construction material (Table I) or a combination of the two is conceivable. For such lightweight constructions the displacement of the beam (1) caused by a force F (e.g. weight of the processing head $F=m_{head}g$) is higher because E as well as I are usually reduced. The Young's Modulus of lightweight material like aluminum and aluminum foam is a fraction of the

Young's Modulus of steel (Table I). The same applies to the moment of inertia of a massive compared to a hollow cross section (Fig. 1).

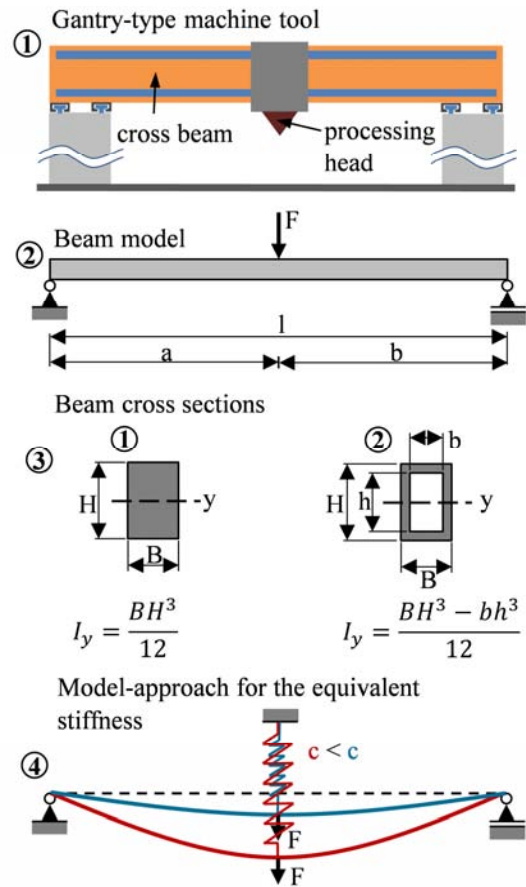

Fig. 1 Example of a lightweight gantry type machine tool (subplot 1); corresponding beam model (subplot 2); possible cross sections (subplot 3); model approach for the equivalent stiffness of the cross beam (subplot 4)

TABLE I
 YOUNG'S MODULUS OF DIFFERENT CONSTRUCTION MATERIALS

Material	Young's Modulus [GPa]
Steel	~ 210
Aluminum	~ 70
Aluminum metal foam	~ 22

The model approach in subplot 4 (Fig. 1) calculates the equivalent pose-dependent stiffness c_{eqv} of the cross beam using the Hook's law and the weight of the processing head (mass m_{head} times gravity g)

$$c_{eqv} = \frac{F}{x(l_x)} = \frac{m_{head}g}{x(l_x)} \quad (2)$$

Using (1) and (2) the equivalent pose-dependent eigenfrequency of the cross beam is calculated as follows

$$\omega(l_x) = \sqrt{\frac{c}{m}} = \sqrt{\frac{c_{eqv}}{m_{head}}} = \frac{1}{ab} \sqrt{\frac{3EI}{m}} \quad (3)$$

In (3) m is interpreted as m_{head} , which is assumed to be constant, as the mass for spindles, lasers or printing heads does not change for lightweight machine applications.

The very simple cross beam model (Fig. 1) and the derivation of its equivalent pose-dependent eigenfrequency allows the following conclusions:

- 1) The equivalent dynamic stiffness of lightweight machine tool structures is smaller than of massive ones (2). The reduction basically depends on E and I of the lightweight design.
- 2) The reduced dynamical stiffness of a lightweight structure causes a lower equivalent structural eigenfrequency (3).
- 3) The structural vibration amplitudes of lightweight structures are higher than of massive ones, as the displacement (1) is higher for lightweight machine tool structures than for massive ones.
- 4) The equivalent structural eigenfrequency (3) of lightweight machine tool structures is pose-dependent. The frequency depends on the position (represented by a and b) of the acting force. This model approach shows that the structural eigenfrequency of massive machine tools is as well pose-dependent. If it is assumed that the damping coefficients in lightweight machine tool structures are similar to the ones in massive machine tools, the pose-dependency of lightweight machine tool structures is nonetheless more challenging. The excited vibrations in smaller frequency ranges need more time to decay and the amplitudes are higher. Active pose-dependent vibration reduction is inevitable.

In the described very simple model approach the challenges of using lightweight structures in machine tools are basically discussed. However, the approach neglects effects like e.g. the mass of the structural components itself, the use of carbon fibres or material combinations for construction materials, anisotropic component behavior or variable component sections. The influence of these factors on the pose-dependent dynamic behavior of lightweight machine tool structures needs to be investigated in the future. Nevertheless, the experimental modal analysis of a lightweight machine tool test structure verifies the occurrence of pose-dependent structural eigenfrequencies in reality. Section III depicts the results of this experimental investigation. For further verification, the experimental modal analysis of an industrial lightweight gantry-type machine tool is planned.

III. EXPERIMENTAL INVESTIGATION OF A LIGHTWEIGHT MACHINE TOOL TEST STRUCTURE

The pose-dependency of the lightweight machine tool test structure in Fig. 2 is experimentally investigated in this section. The experimental modal analysis verifies the basic statement on the pose-dependent dynamic behavior of simply built lightweight machine structures. The test structure represents a travelling column machine kinematics with a manually moveable ram in vertical and horizontal direction.

The lightweight machine tool test structure consists mainly of continuous casting aluminum profiles with force-fit screw connectors. Its column is a frame design with a mass of approx. 80 kg and the dimensions depicted in Fig. 2. For this

modal testing, the test structure is a passive machine configuration with manually adjustable axes. Thus, the ram and its cage, with a mass of 12 kg and 9 kg, can be shifted in vertical and horizontal direction. The axis components such as bearings and guide rails are replicated. Like in a real machine tool, the guide rail of the ram cage has a vertical degree of freedom (dof) oriented to the travelling column. This dof is fixed by the clamping of the ram cage at the ball screw drive replica. Hence, the lightweight machine tool test structure contains all components of a real lightweight machine that are relevant for its dynamic behavior.

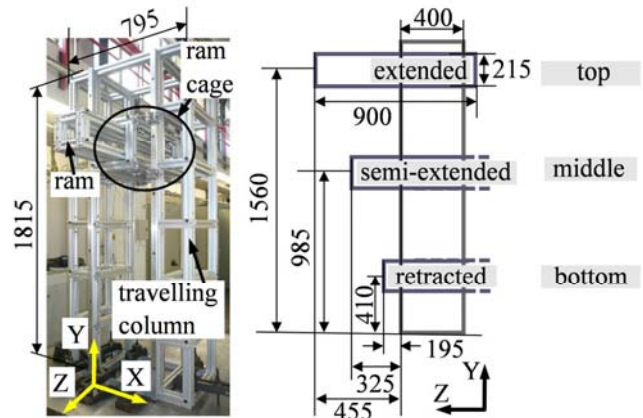

Fig. 2 Lightweight machine tool test structure (left: CAD-model (dimensions in mm); middle: real prototype; right: investigated poses)

In the experimental analysis, nine remarkable poses are chosen. Those are segmented in the configurations of the ram as depicted in Fig. 2 (top, middle, bottom and extended, semi-extended, retracted). The dynamic behavior is investigated through modal testing with an impact hammer and ICP accelerometers applied to the structure.

In Fig. 3 the eigenmodes of the lightweight machine tool test structure are represented as they generally appear in the frequency consecutively. Those are bending and torsion modes of first and higher degrees around the axes. The corresponding pose-dependent eigenfrequencies of the first bending mode around the x-axis is listed in Table II.

TABLE II
 EIGENFREQUENCIES OF THE 1ST BENDING MODE IN X-DIRECTION FOR THE NINE CONSIDERED POSES

Pose	extended [Hz]	semi-extended [Hz]	retracted [Hz]
top	11.87	11.88	11.89
middle	13.73	13.72	13.73
bottom	15.97	15.94	15.93

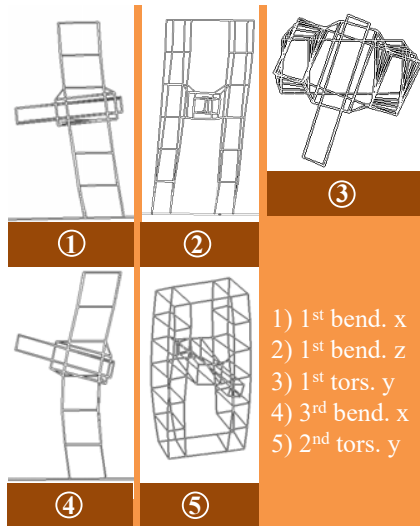

Fig. 3 First eigenmodes of the lightweight test structure in order of appearance in the frequency spectrum.

The comparison of the resulting eigenfrequencies for the first bending mode (Table III) of each pose shows that a pose-dependency is identifiable. Basically, the higher the ram is positioned, the lower are the eigenfrequencies. The differences are approx. 2 Hz, around 15%, compared to the vertical position. For the alteration of the dynamic behavior the displacements of the ram in vertical direction are much more significant than in horizontal. Between the horizontal configurations the frequencies differ hardly. The reason for this phenomenon is that the shift of mass and the change of inertia are quite different. In Fig. 4 the accumulated frequency response functions of all measurement positions for the configuration with a semi-extracted ram are shown. In every pose the first three eigenfrequencies are conspicuous. In the bottom pose the second and third eigenfrequencies are merging because the distance of 1 Hz and a damping ratio of approx. 1% causes no distinct antiresonance. The changing of the dynamic behavior seems to be linear in this example.

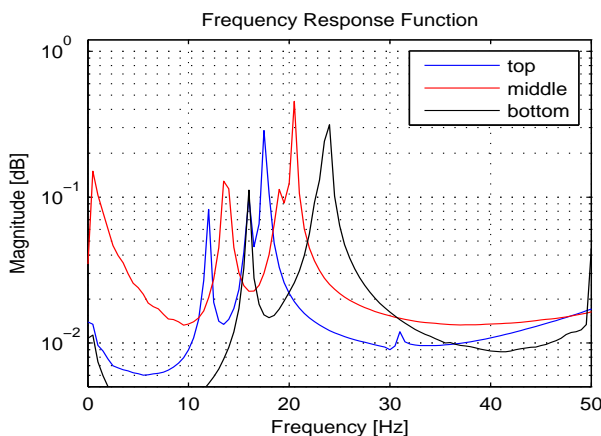

Fig. 4 Accumulated frequency response functions (FRFs) of the three prominent eigenfrequencies for a semi-extracted ram.

As the impact of horizontal shifting is not essential for the pose-dependency of the test structure it is not discussed any further. In Table III the further eigenfrequencies of the modes in Fig. 3 with a semi-extended ram are listed.

TABLE III
 EIGENFREQUENCIES OF THE HIGHER MODES OF THE LIGHTWEIGHT TEST STRUCTURE (RAM IN SEMI-EXTENDED POSITION) FROM EXPERIMENTAL MODAL ANALYSIS

Mode	1 st bend. x [Hz]	1 st bend. z [Hz]	1 st tors. y [Hz]	3 rd bend. x [Hz]	2 nd tors. y [Hz]
top	11.88	15.89	17.62	65.29	65.90
middle	13.72	19.09	20.50	62.42	86.31
bottom	15.94	22.72	23.78	57.00	74.37

It is obvious that also for higher eigenfrequencies pose-dependency exists. Like in Table II, the differences in the frequencies are around 2-3 Hz caused by a vertical movement of the ram, except for the second torsion mode. Between the first three and the higher eigenfrequencies, there is a large spectrum where no eigenfrequency appears. This can be explained by the vertical position of the ram. The ram and its fixing connectors are blocking a mode and the frequencies are increasing intensively (see pose: 2. torsion mode in Fig. 3). In comparison to the top and bottom poses, the middle positioned ram causes nearly half an oscillation length for higher torsion modes).

Summarized, the experimental modal analysis verifies that the lightweight test structure has a pose-dependent dynamic behavior in form of pose-dependent eigenfrequencies and eigenmodes. Generally, the first three eigenmodes of the test structure are the most relevant ones, as they have the highest vibration amplitudes. These three eigenmodes have a frequency range of about 12 Hz-24 Hz, depending on the position of the ram. Looking at the first eigenmode, the bending mode around the x-axis, its eigenfrequency varies about 25% between the highest and the lowest position of the ram. This aspect is very relevant for the active control, respectively vibration reduction, for lightweight machine tools. In the following section, first, an overview on vibration reduction for machine tools is presented. Afterwards, the consequences of the pose-dependent dynamic behavior of lightweight machine tool structures are presented.

IV. VIBRATION REDUCTION AND CONTROL STRATEGIES FOR LIGHTWEIGHT MACHINE TOOL STRUCTURES

The vibrations of machine tools can lead to the production of work pieces exceeding the production tolerances. These vibrations can be divided into externally excited and self-excited ones [7]. Externally excited vibrations are primarily caused by positioning movements, vibrations of the base or the machining process. Chattering as one possibility of self-generative vibrations is produced by interaction of the machining process with the flexible machine structure [8]. While acceleration and deceleration of the axes as well as shocks excite the machine structure transiently in its weakly damped natural frequencies, the machining process creates vibrations with the tooth passing frequency. The externally

excited vibrations and mostly the chattering are vibrations of the spindle and tool holder as well as the work piece mount within the range of several hundred to several thousand Hertz [3]. Structural vibrations lie usually between 30 Hz and 120 Hz, for lightweight machine tools even lower. For vibration reduction of lightweight machine tools various methods are available (Fig. 5).

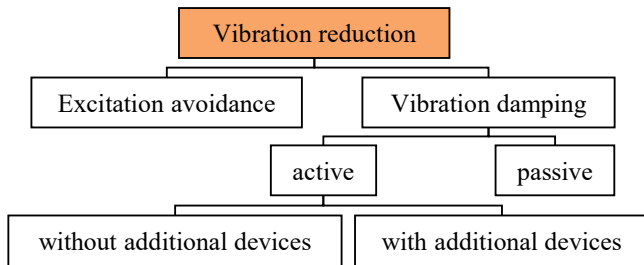

Fig. 5 Overview of vibration reduction in machine tools

Generally, a distinction is made between excitation avoidance and vibration damping. In case of excitation avoidance only the avoidable sources based on the interaction of acceleration and deceleration forces with the machine structure during axes motion are considered. The more continuous the jerks in the motion profile, the lower the excitation of the machine structure. Jerk-limited motion profiles with rectangular or even sin2-jerks are advantageous. The frequency spectra of these profiles show gaps that can be used to filter the critical structural resonance frequency. Besides the motion profile, also the path profile imprints vibrations into the machine tool structure if the path curvature is not continuous. In order to avoid this, various spline interpolations as, for example, the Cornu spline are developed [9]. A further possibility, at the risk of a path deformation, would be the filtering of the set points after their generation, or filtering of the manipulated variable within the velocity control loop [10], [11]. Vibration damping is divided into active and passive methods. The active methods regarded here can further be subdivided into methods with or without additional devices. In the latter case, this is mostly a drive-based vibration reduction. [10], for example, measures the disturbing vibration and generates a counteracting vibration with a phase shift of 180° via the feed drive. Drive-based vibration damping is limited to the bandwidth of the drive and, therefore, only applicable for low-frequency critical natural frequencies. Active vibration damping with additional devices is often done via inertial mass dampers. They are based on the principle that the acceleration of a suspended mass results in a reaction force at the supporting structure. The force between the inertial mass and the support structure can be generated electrically [12], [13], hydraulically, or piezoelectrically. Reference [14] developed an adaptronic rod using a piezo stack actuator, which directly introduces the force into the structure. Besides the additional costs, the control of the additional actuators can be somehow complicated. Due to the differing physical operating principles, vibration reduction methods can only be effective in a specified frequency range

and against defined causes. Whereas, for example, drive-based vibration reduction is mostly suitable only for low-frequency structural vibrations, piezo actuators are useful for damping high-frequency oscillations with small deflections. Using these methods for vibration reduction of lightweight machine tools, the pose-dependency and the low frequency range of the vibrations have to be considered. Input shaping, as one well-suited example for vibration avoidance for lightweight machine tools, needs the input of the exact frequency, which needs to be avoided. Otherwise, the critical frequencies cannot be eliminated efficiently. Fig. 6 shows the sensitivity curves for different input shapers which depict the residual percentage vibration depending on the normalized frequency.

A ZV shaper is applied to the lightweight test structure (Section III) and the filtering frequency is adjusted to the middle pose of the ram (13.72 Hz). Then, the bending mode in x-direction would not be excited if the ram is positioned vertically in the middle. But, if the ram is positioned at the bottom of the travelling column, a residual vibration of about 25% ($\omega_a/\omega_m \approx 1,16$) would be the consequence. Advanced control strategies like in [14], model predictive control or controls with inverted system models react very sensitive to uncertainties in the plant model as well. So, for the active control, respectively the vibration reduction of lightweight machine tools, this means that the pose-dependent dynamic behavior must be exactly known for the actual state of the machine. Otherwise, an efficient use of the presented methods is not possible. Therefore, in the following section, the state of the art of pose-dependent dynamic machine tool models is described.

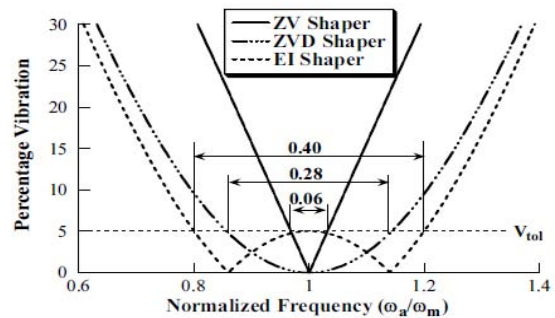

Fig. 6 Input shaper sensitivity curves [11]

V. STATE OF THE ART OF POSE-DEPENDENT DYNAMIC MACHINE TOOL MODELS

Generally, there are different approaches to model the dynamic behavior of machine tools. One possibility is the theoretical modelling based on physical considerations and equations. The other possibility is the parametric and non-parametric experimental modelling. The parametric experimental modelling emanates from a parametric model based on apriori-knowledge. Its parameters are identified experimentally. Afterwards, a mathematical model description in form of equations is available. The non-parametric modelling results in value tables and graphs gained by measurements and experiments.

Regarding the actual investigation and modelling of the (pose-dependent) dynamic behavior of machine tools, there are two different scenarios, when models of the dynamic and static machine tool behavior are relevant. The first is the simulation of the machine models for design improvements and the second the tuning of actual conventionally used feed drive controllers. Commonly, theoretical models are used in the design phase when no machine tool prototypes are available. When the dynamics of the real prototypes can be measured, (non-)parametric experimental dynamic models are also available.

Popular examples for experimental investigations and models are the measurement of frequency response functions, a modal analysis or an operational modal analysis. Frequency response functions (FRFs) are often used to tune controllers of feed axes. FRFs are mostly easy to measure as regular drives integrate these measurement options. However, systematical measurements of FRFs in each possible combination of the axes' positions are not commonly used as it means a high expenditure of time. Furthermore, these FRFs measure primarily the response behavior of the feed drive. Structural vibrations are not necessarily visible in the FRFs and very difficult to interpret.

An Experimental Modal Analysis (EMA) is a common tool for a reliable measurement of the dynamic behavior of an existing machine tool. However, the time expenditure for a detailed EMA in one pose is so high that it is unconceivable to systematically measure each machine for several defined poses, not least because expert knowledge is required. Furthermore, EMAs are performed on turned off machines or machines in standby. This machine state not always reflects the dynamic behavior the machine shows while processing.

The operational modal analysis (OMA) offers an improvement regarding the facts mentioned above. There, the eigenmodes and eigenfrequencies of the machine are measured while machining a special test work piece [15], [16]. That means, OMA offers the possibility to automatically measure the machine dynamics before the real machining process. However, it is still very time-consuming to repeat this measurement for many poses within the working space. Furthermore, there has to be the possibility to clamp the work piece in every position within the working space.

As the dynamical machine behavior changes in identically constructed machines and over a machine's entire life cycle [17], the experimental non-parametric modelling, respectively the measurements, have to be repeated in defined time steps. Furthermore, for using a pose-dependent dynamic machine model for active control and vibration reduction, the individual measurement results for each machine pose have to be merged to one global pose-dependent model. The global pose-dependent model has to be effective due to calculation time and data storage.

Theoretical modelling of the pose-dependent dynamic machine tool behavior for design improvements [18], [19] and real-time computation in controllers [20] is subject of research.

Reference [18], for example, models a flexible machine tool, a waterjet cutting machine, on several positions beforehand and used those linear models to predict the pose-dependent system behavior. For high accuracy, the dynamic behaviors in many poses have to be calculated. The effort of evaluating a FE-model in different positions is very high as the FE-model has to be manually changed for each pose.

A position-dependent, substructurally synthesized machine model of reduced order for structural design modifications and topology optimization is created by [19] considering the position-dependent process-machine interactions. The pose-dependency of the dynamic behavior like in [18] is evaluated at a few discrete positions with discrete machining process interactions.

Reference [20] follows a substructurally reduced order approach based on detailed finite element models. There, process force interactions are not considered, but the continuous machine movement is integrated into the dynamic machine model. Thus, this approach allows simulating a nearly continuous pose-dependent dynamic machine tool behavior. The model is real-time capable and can be used for autotracking of control parameters.

A great disadvantage of theoretical modelling is that there is no verification of the model compared to the real dynamic machine behavior. Consequently, no statements on the accuracy of these models can be posted. Therefore, in the following section, the accuracy of the FE-model of the lightweight machine tool test structure is compared to the results of the experimental modal analysis of the system in Section III.

VI. CRITERIA FOR POSE-DEPENDENT DYNAMIC MACHINE TOOL MODELS

Within this section, the criteria for a pose-dependent dynamic machine model for the use in active control algorithms are summarized. First, however, the correspondence of the computed eigenfrequencies of a simulation using a relatively simple FE-model of the lightweight test structure with the experimental results is analyzed.

For an exact prediction of the pose-dependent dynamic behavior of the FE-model, a numerical modal analysis is attempted. The lightweight machine tool test structure is modelled with FE-Analysis by ANSYS 13.0 Classic. The machine parts are meshed by Beamelement 188 (Timoshenko). A cross section is assigned to each element. Thus, extruded FE-parts are defined (Fig. 7) for the continuous casting aluminum profiles (all other machine parts such as fixing connectors are modelled in the same way).

The structure is modelled with the same positions of the ram and its cage like in the experimental measurement with the real machine tool test structure. In the first simulation, the material properties were defined with standard aluminum and steel values. Twice as high eigenfrequencies result because the profile screw connectors are modelled like rigid connectors. Thus, the parameters of the material properties are adapted for achieving the eigenfrequencies of the experimental analysis.

This adaption is based on the semi-extended pose in the middle for the eigenfrequencies of the modal tested investigation. Thereby, the Young's modulus of the aluminum strut profiles was decreased from 70 GPa to 27 GPa. The resulting eigenmodes fit well to those determined by the experiment, whereas the eigenfrequencies differ substantially as can be seen in Table IV. There, the relative differences of the frequencies based on the experimental solution are also listed. Nevertheless, the resulting values of the numerical analysis show pose-dependency as well. To improve the compliance of the results, the model can be defined in a more detailed way. For example, the profile connectors could be modelled not rigidly but with spring elements. However, definition and parameter settings of these elements are difficult for simulating the reality. Without comparison to measurement values, it is probably impossible to set them in the way that the model exactly reflects the real machine behavior. Furthermore, the best fitting parameter sets most likely differ for every eigenmode. This effect can be seen in Table IV as well. There, the eigenfrequencies fit for one eigenmode rather well, while the eigenfrequencies of the other modes differ very much. Here, the model parameters would need to be readjusted.

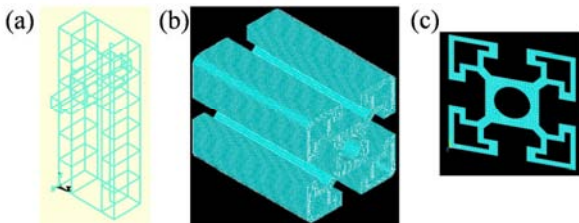

Fig. 7 FE-model approach for the lightweight machine tool test structure (a) edge model, (b) meshed beam element, (c) meshed beam cross section

TABLE IV
 EIGENFREQUENCIES OF THE HIGHER MODES OF THE LIGHTWEIGHT TEST STRUCTURE (RAM IN SEMI-EXTENDED POSITION) FROM MODAL ANALYSIS OF THE MODEL IN ANSYS

Mode	1 st bend. x [Hz]	1 st bend. z [Hz]	1 st tors. y [Hz]	3 rd bend. x [Hz]	2 nd tors. y [Hz]
top	15.19 (+28%)	14.64 (-8 %)	18.06 (+2 %)	54.47 (-17 %)	57.31 (-13 %)
middle	17.04 (+24%)	17.27 (-10 %)	19.88 (-3 %)	53.41 (-14 %)	85.65 (-1 %)
bottom	19.07 (+19%)	19.00 (-17 %)	22.03 (-7 %)	49.54 (-13 %)	63.45 (-15 %)

The pose-dependent numerical evaluation of an FE-model is very time-consuming (compare [18]). Furthermore, this example shows that for a correct pose-dependent dynamic machine tool behavior simulation a highly detailed FE-model is needed. But, the more detailed the model is, the more expensive parameter identification and parameter settings are necessary. A pose-dependent FE-model for active control of lightweight machine tool structures without verification with experimental analysis is hardly expedient.

Based on these results and the results of section V, a pose-dependent dynamical machine tool model for the efficient use

for active control, respectively vibration reduction algorithms must meet the following criteria:

- Sufficient accuracy: The model has to reliably fit to the real machine tool dynamics within defined boundaries depending on the vibration reduction strategy the model is applied for.
- The model has to reliably describe the pose-dependent dynamic behavior.
- The model has to reliably fit the real machine tool dynamics for different machining states within the whole machine tool's lifecycle.
- Simple applicability (without expert knowledge and with efficient use of time).
- Real-time capability.

In the outlook, one approach for a pose-dependent dynamical machine model for the use for vibration reduction of lightweight machine tool structures is presented.

VII. OUTLOOK – NEW APPROACH FOR A POSE-DEPENDENT DYNAMIC MACHINE TOOL MODEL FOR VIBRATION REDUCTION

The goal of this approach is to combine theoretical and parametric experimental modelling for the aim of an exact pose-dependent dynamic machine model, which can be used for the active vibration reduction of large lightweight machine tools. In Fig. 8, general parametric machine models for large lightweight machine tool structures are derived. The options for machine kinematics for large work pieces are limited. Because of the space available and the mass ratios, kinematics with just tool-sided movements are preferred [5]. So, for the generalized parametric machine model, only gantry-type or travelling column machine tool kinematics are considered. The model parameters are updated online depending on the actual machine tool dynamic behavior (Fig. 8). The parameter adjustments due to changes in the pose of the machine tool structure are of central importance. Therefore, internal measurement systems (positions, velocity, forces and moments) as well as additional external sensors (e.g. acceleration) are used. The general machine model, which represents the actual dynamic behavior of the large lightweight machine tool structure, can be applied e.g. for vibration reduction methods.

Because of realtime-capability and easy applicability, the general machine model is to be modelled as simply as possible. But, the adjusted model has to fit the dynamic machine tool behavior within defined boundaries. The necessary accuracy of the adjusted model is defined by the vibration reduction method the model knowledge is used for. Besides that, the vibration reduction method defines the following points:

- Kind and number of eigenmodes, which have to be modelled by the general machine model. These modes are controlled afterwards.
- Frequency range of interest.
- Modelling of the compliance by a finite segment (FS) approach is sufficient or a flexible multi-body system (FMBS) approach is necessary.

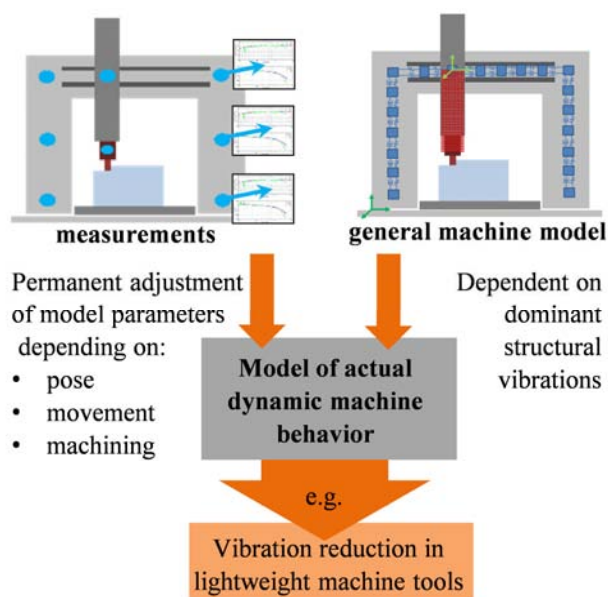

Fig. 8 Approach for a pose-dependent dynamic machine tool model for vibration reduction of lightweight machine tools.

Since the general machine model is very simple, but the dynamic behavior of the real machine changes permanently within the working space and under real machining conditions, the parameters of the general machine model need to be adjusted online. The used updating method also defines the specific structure of the general machine model:

- Number of parameters to be updated: Depending on the amount of bodies and the modelling strategy of compliances (FS or FMBS approach). This defines the quantity of necessary input signals for parameter updating.
- Consideration of axes' movement within the model: This defines if the model is invariant or variant in its structure.
- Storage of the model knowledge and usage of previously acquired knowledge.
- Real-time capability.

The structure of the equation of movement of the model and the dependency of the parameters to be updated is most relevant for the definition of the parameter updating method. This defines the system of equations for the calculation of the unknown parameters.

Applying the presented approach to a large-scale lightweight machine tool in combination with the active control of this machine tool is subject of the authors' future work.

ACKNOWLEDGMENT

The author S. Apprich would like to thank the German Research Foundation (DFG) for financial support of the project within the Cluster of Excellence in Simulation Technology (EXC 310/2) at the University of Stuttgart.

REFERENCES

- [1] A. Karim, A. Verl, and R. Höhne, "Schwingungsanalyse an Bearbeitungsrobotern. Durchführung einer experimentellen Modalanalyse an Industrierobotern," *wt Werkstatttechnik online*, vol. 104, pp. 49–54, 2014.
- [2] H. Vieler, A. Karim, and A. Lecher, "Drive Based Damping for Robots with Secondary Encoders," in *The International Conference on Flexible Automation and Intelligent Manufacturing 2015*.
- [3] J. J. Zulaika, F. J. Campa, and Lopez de Lacalle, L. N., "An integrated process-machine approach for designing productive and lightweight milling machines," *International Journal of Machine Tools and Manufacture*, vol. 51, pp. 591–604, 2011.
- [4] P. Sekler, A. Dietmair, A. Dadalau, H. Rüdeler, J. Zulaika, J. Smolik, et al., "Energieeffiziente Maschinen durch Massenreduktion. Energiebedarf von Produktionsmaschinen senken durch Reduktion bewegter Massen und steuerungstechnische Kompensation der Steifigkeitsverluste," *wt Werkstatttechnik online*, vol. 97, pp. 320–327, 2007.
- [5] L. Uriarte, M. Zatarain, D. Axinte, J. Yagüe-Fabra, S. Ihlenfeldt, J. Eguia, et al., "Machine tools for large parts," *CIRP Annals - Manufacturing Technology*, vol. 62, pp. 731–750, 2013.
- [6] H. Dubbel, W. Beitz, K.-H. Küttner, and B. J. Davies, *Dubbel. Handbook of mechanical engineering*. London, New York: Springer-Verlag, 1994.
- [7] A. Dietmair, P. Sekler, J. Larranaga, J. Sveda, M. Sultika, and A. Bustillo, "Schwingungsreduktion bei Produktionsmaschinen. Ein Überblick über Methoden zur Schwingungsunterdrückung und Anregungsvermeidung," *wt Werkstatttechnik online*, vol. 97, pp. 307–313, 2007.
- [8] Y. Altintas, *Manufacturing automation. Metal cutting mechanics, machine tool vibrations, and CNC design*. Cambridge, New York: Cambridge University Press, 2012.
- [9] C. Dripke, F. Groh, M. Keinert, and A. Verl, "A New Approach to Interpolation of Tool Path Trajectories with Piecewise Defined Clothoids," pp. 249–254.
- [10] A. Dietmair and A. Verl, "Drive Based Vibration Reduction for Production Machines," in *International Congress MATAR 2008*, Prag, September 16-17.
- [11] W. Singhose, "Command shaping for flexible systems: A review of the first 50 years," *Int. J. Precis. Eng. Manuf.*, vol. 10, pp. 153–168, 2009.
- [12] N. Loix and J. P. Verschueren, "Stand Alone Active Damping Device," in *9th International Conference on New Actuators (ACTUATOR 2004)*, Bremen, June 14-16.
- [13] E. Abele, M. Roth, C. Ehmann, and M. Haydn, "Aktiver Strukturdämpfer. Dimensionierung, Konstruktion und Verifikation an einem Bearbeitungszentrum," *wt Werkstatttechnik online*, vol. 100, pp. 105–111, 2010.
- [14] A. Ast, S. Braun, P. Eberhard, and U. Heisel, "An adaptionic approach to active vibration control of machine tools with parallel kinematics," *Prod. Eng. Res. Devel.*, vol. 3, pp. 207–215, 2009.
- [15] B. Li, H. Cai, X. Mao, J. Huang, and B. Luo, "Estimation of CNC machine-tool dynamic parameters based on random cutting excitation through operational modal analysis," *International Journal of Machine Tools and Manufacture*, vol. 71, pp. 26–40, 2013.
- [16] I. Zaghbani and V. Songmene, "Estimation of machine-tool dynamic parameters during machining operation through operational modal analysis," *International Journal of Machine Tools and Manufacture*, vol. 49, pp. 947–957, 2009.
- [17] M. Reuss, A. Dadalau, and A. Verl, "Friction Variances of Linear Machine Tool Axes," *Procedia CIRP*, vol. 4, pp. 115–119, 2012.
- [18] A. Jönsson, J. Wall, and G. Broman, "A virtual machine concept for real-time simulation of machine tool dynamics," *International Journal of Machine Tools and Manufacture*, vol. 45, pp. 795–801, 2005.
- [19] M. Law, Y. Altintas, and A. Srikantha Phani, "Rapid evaluation and optimization of machine tools with position-dependent stability," *International Journal of Machine Tools and Manufacture*, vol. 68, pp. 81–90, 2013.
- [20] P. Sekler and A. Verl, *Real-Time Computation of the System Behaviour of Lightweight Machines. A Possible way for Vibration Reduction for Production Machines*. Porto, 20-25 September.