

Determination of the Pullout/Holding Strength at the Taper-Trunnion Junction of Hip Implants

Obinna K. Ihesiulor, Krishna Shankar, Paul Smith, Alan Fien

Abstract—Excessive fretting wear at the taper-trunnion junction (trunnionosis) apparently contributes to the high failure rates of hip implants. Implant wear and corrosion lead to the release of metal particulate debris and subsequent release of metal ions at the taper-trunnion surface. This results in a type of metal poisoning referred to as metallosis. The consequences of metal poisoning include; osteolysis (bone loss), osteoarthritis (pain), aseptic loosening of the prosthesis and revision surgery. Follow up after revision surgery, metal debris particles are commonly found in numerous locations.

Background: A stable connection between the femoral ball head (taper) and stem (trunnion) is necessary to prevent relative motions and corrosion at the taper junction. Hence, the importance of component assembly cannot be over-emphasized. Therefore, the aim of this study is to determine the influence of head-stem junction assembly by press fitting and the subsequent disengagement/disassembly on the connection strength between the taper ball head and stem.

Methods: CoCr femoral heads were assembled with High stainless hydrogen steel stem (trunnion) by Push-in i.e. press fit; and disengaged by pull-out test. The strength and stability of the two connections were evaluated by measuring the head pull-out forces according to ISO 7206-10 standards.

Findings: The head-stem junction strength linearly increases with assembly forces.

Keywords—Wear, modular hip prosthesis, taper head-stem, force assembly, force disassembly.

I. INTRODUCTION

JOINT Arthroplasty (JA) is a procedure of orthopaedic surgery whereby the arthritic or diseased joint surface is exchanged with an artificial orthopaedic prosthesis for significant improvement in the relief of pain, mobility and quality of life. With rising life expectancy, hip and knee joint problems are increasingly common over the recent years. Broadly speaking, total hip replacement (THR) identifies about one million THR surgeries performed worldwide each year [1]. Studies have demonstrated that approximately 90,000 Australians undergo joint replacement surgery each year [2]. Whereas about 200,000 and 80,000 interventions/year are conducted in the USA and UK, respectively, and they are estimated to increase by about 170% by 2030 i.e. similar data from USA predicts that by 2030 the number of replacements

Obinna. K. Ihesiulor is with the School of Engineering and Information Technology, University of New South Wales Canberra, Northcott Drive, Campbell ACT 2612, Australia (Corresponding author, e-mail: o.ihesiulor@adfa.edu.au).

Krishna Shankar and Alan Fien are with the School of Engineering and Information Technology, University of New South Wales Canberra, Northcott Drive, Campbell ACT 2612, Australia.

Paul Smith and Diana Perriman are with the Trauma and Orthopaedic Research Unit, Canberra Hospital, PO Box 11, Woden, ACT 2606, Australia.

in a given year will increase to 4.05 million [3]. Joint replacement technologies have improved in recent years with average time to revision increasing. Damaged natural hip joints replaced with prostheses are usually expected to have a life expectancy of 15-20 years [4]. Unfortunately, though the success rates of the procedures performed have increased substantially since the 1960s, up to 10% of procedures conducted are revision operations to replace joints, which have failed prematurely.

Hip replacement (hip arthroplasty) is defined as a surgical procedure to replace a worn out or diseased/damaged hip with an artificial joint called prosthesis, a device that substitutes a joint. This surgery may be performed due to hip fracture or severe pain caused by arthritis. Hip replacement is composed of a femoral stem, sunk into the medullary canal of the femur; a femoral neck, connecting the stem to the head and an acetabular cup that is embedded in the pelvis, in some cases through a backing insert as shown in Fig. 1.



Fig. 1 Components of a hip prosthesis

With the increasing familiarity of larger bearing diameters, the need to achieve a secure stable connection of the head-stem is essential. Manufacturers presently provide only peripheral procedure such as to apply “a light tap” to seat the head and that “excessive forces” could destroy the head-stem junctions [5], [6]. Influence of the assembly procedure on the head-stem stability has been successfully used to evaluate several different prostheses as well as to optimize designs. Although this is not fully incorporated to yield expected results, there are a number of valuable contributions [7]-[9]. This study therefore, potentially focuses on the influence of assembly force on the taper head-stem junction strength for tapered head-head stem as shown in Fig. 2.

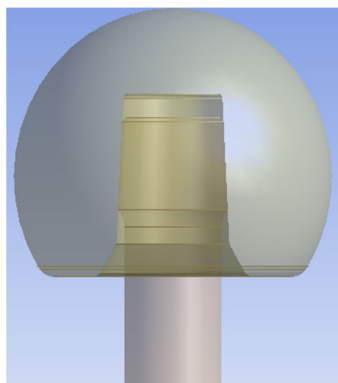

Fig. 2 Tapered stems (Taper head-stem)

II. MATERIALS AND METHODS

A. Materials

Two ball heads (tapered heads) with tapered holes made up of cobalt chrome material used in this study were obtained from the manufacturer and supplier, Signature Orthopaedics, Australia. The stems/trunnions used for the testing were made up of High Stainless Hydrogen Steel. These were machined up to five pieces as shown in Fig. 2 from the High Stainless Hydrogen Steel rod supplied by the same manufacturer.

The femoral heads are of 12/14 taper with 40 mm diameter and offset of +4 and -4 were used for testing. Taper angle of the taper head were measured by the manufacturer to be 5042'30'' while other design parameter dimensions are shown in Fig. 2. The distal part of the stem was completed fixed in order not to allow stem movement at the bottom.

The two different combinations of tests were investigated:

- Taper ball head and stem assembly
- Taper ball head and stem disengagement

B. Materials properties for the testing

Different materials are used in the present study to simulate the pull-out forces for the different designs of hip implants. These materials are Cobalt Chromium (Co Cr Mo) for the head and High Hydrogen Stainless Steel for the stem implant. They are utilized owing to their high strength and sufficient biocompatibility in clinical conditions. All the materials for the hip joint components are assumed to be isotropic and linearly elastic obeying Hooke's Law. The values of elastic modulus and Poisson's ratio of the hip joint materials are summarized in Table I.

C. Assembly Procedure

Ball head and stem were assembled by quasi-static 'Push-in'. Peak applied force of 3kN was chosen to be tested as the input variable with regard to taper head-stem connection strength. For quasi-static assembly, the load was applied through a 50 kN SHIMADZU universal testing machine with a constant loading rate of 2 mm/min. This was put under force control according to ISO 7206-10. The test fixture designed to carry out the experiment for the force application/assembly is shown typically in Fig. 3. The force application is done by carrying out a compression testing using the SHIMADZU

machine. Fig. 4 shows the test setups of the assembly procedure under different applied loads.

TABLE I
 MECHANICAL PROPERTIES OF THE MATERIALS USED IN THE HIP

Material	Young's Modulus (GPa)	Poisson's Ratio
Co-Cr-Mo (Ball head)	210	0.31
High Hydrogen Stainless Steel (Stem/Trunnion)	195	0.3

For the Push-in test, measurement of compressive applied forces required to assemble the taper unto the stem/trunnion (force of impact/assembly) were taken i.e. compression tests with tapered stems to determining the push-in force required for assembly. The Push-in assembly procedure is shown in Figs. 3 and 4. Six axially applied peak assembly forces were used 0.5kN, 1kN, 1.5kN, 2kN, 2.5kN and 3kN. These are within the range commonly used by surgeons for femoral head seating, 2kN corresponding to a 'light' hammer blow and 4kN to a 'firm' hammer blow using a surgical metal hammer [8].

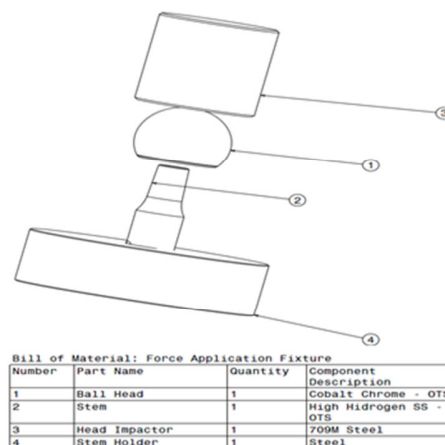

Fig. 3 Test fixture designed for the force assembly/impaction using the Shimadzu machine via compression testing



Fig. 4 Test setup of the Push-in assembly used for force application of the ball head against the stem

D. Disassembly

The disassembly procedure used was a pull-out test performed at a rate of 2mm/min according to ISO 7206-10. This is carried out to determine the pull-out forces required to disengage the ball head from the stem. Pull-out tests are

commonly used to determine the junction strength between femoral head and stem [7]-[9] as shown in Figs. 5 and 6. For the pull-out tests, measurements of tensile forces required to disassemble the taper from the trunnion after impaction/assembly (force of pull-out/disassembly) i.e. tensile tests to determine the pull-out force as a function of push-in force is carried out.

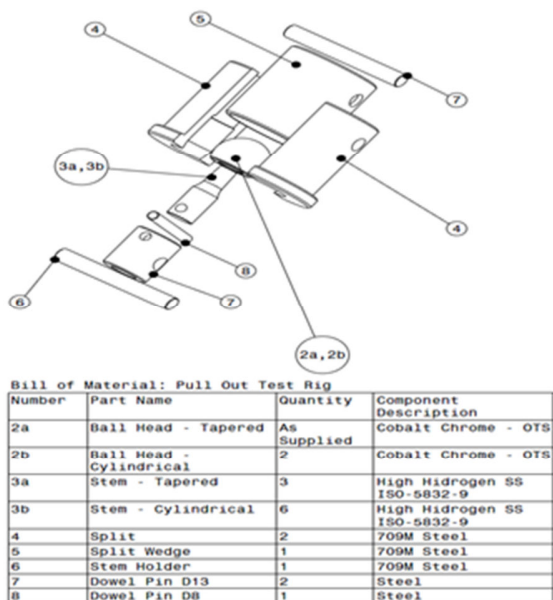

Fig. 5 Pull-out test rig to disengage/disassemble the head unto the stem

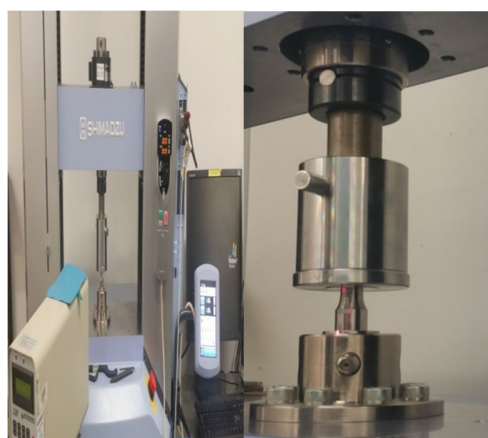

Fig. 6 Test setup of the pull-out forces as a result of the Push-in force

III. RESULTS

Mean pull-out forces relative to the assembly forces for all assembly procedures with applied forces of 0.5kN, 1kN, 1.5kN, 2kN, 2.5kN and 3kN for Sample 1 as shown in Fig. 7 were 43.4% which matches with the results tabulated by [10]. Their result showed that the mean pull-off forces relative to force assembly were 44%. All samples were tested five times (Sample 1, Sample 2 and Sample 3) and the average taken. Results indicate that pull-out forces increased linearly with higher assembly forces with average gradients of 43.4%,

32.9% and 35.5% for Samples 1, 2 and 3 respectively as shown in Fig. 7.

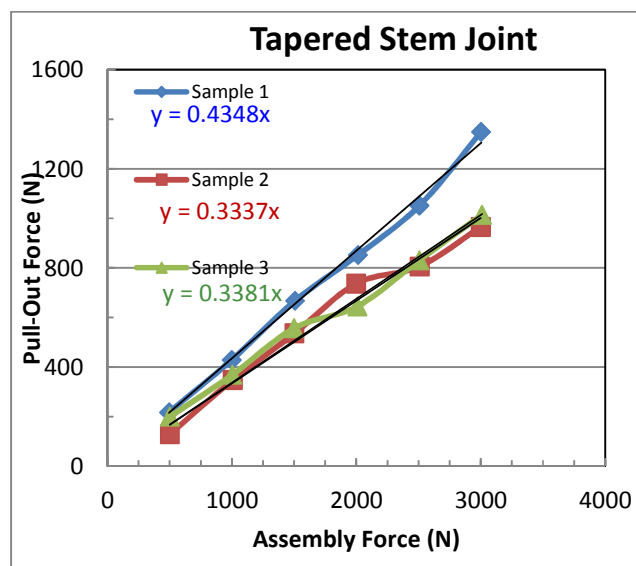

Fig. 7 Pull-out forces achieved for the three samples for the tapered stems depending on different assembly forces

IV. DISCUSSION

Assembly force for taper designs with press fits significantly influence the pull-out forces necessary to disassemble the junction connection between femoral ball head and stem/trunnion of a modular hip prosthesis. The linear correlation found between assembly force and pull-out force corresponds to the results of previous studies [10], [11]. The following deductions are summarized from the obtained results:

- The difference in the gradients of the trend lines observed between the first sample and the other two may be attributed to differences in sample geometry, taper ratio, surface roughness, etc. and may be considered as indicators of the upper and lower trends of pull-out forces required to disassemble tapered stem trunnion joints.
- Even using the upper trendline, for a joint assembled with a firm hammer blow of 4kN, the pull-out force will be less than 1.8kN; and once pulled out it will remain loose and cause wear.
- A comprehensive finite element model is being developed to simulate the wear in the taper trunnion joint and the experimental data will be used to validate the model before studies are performed to analyze and determine the wear in the joint.
- The FE model will further be used to optimize the design of the joint by studying the influence of geometric parameters such as taper ratio, stem diameter and length and head diameter on the pull-out strength.

V. CONCLUSION

This study ultimately represents the attempt to understand the role of assembly forces at the head-stems in the stability of

the modular junction, and thus prevention of micromotion and subsequent wear. It was our hypothesis that the applied force of assembly for the tapered stems has a significant influence on the looseness and tightness of the modular junction of hip prosthesis. The results of this research have shown different withdrawal strength behavior under varying assembly forces. This greatly affects the initial stability at the head-stem junction. This study suggests that to provide sufficient fixation strength and stability between the head and stem connection of modular hip implants that the degree and amount of assembly force is required. Hence, it is necessary to adopt optimization techniques to determine the optimum values of assembly forces to be used and also to determine if wear rates in the tapered-trunnion joints decrease with such forces values while recommending ranges of forces to be used for implants to different dimensions/geometries/loads. These findings would be established in our future work.

ACKNOWLEDGMENT

Obinna K. Ihesiulor is grateful to UNSW Canberra for provision of tuition fee waiver and living allowance support.

REFERENCES

- [1] U. Holzwarth and G. Cotogno., Total hip arthroplasty: State of the art, challenges and prospects. 2012: Joint Research Centre of the European Commission.
- [2] A. O. Association., National Bone and Joint Registry Annual Report. 2011.
- [3] S. Kurtz et al., Projections of primary and revision hip and knee arthroplasty in the United States from 2005 to 2030. *The Journal of Bone & Joint Surgery*, 2007. 89(4): p. 780-785.
- [4] L. Blunt et al., The role of tribology and metrology in the latest development of bio-materials. *Wear*, 2009. 266(3): p. 424-431.
- [5] B. Orthopedics, Precautionary Statement. 2006.
- [6] B. Orthopedics, BIOLOX®delta Option Ceramic Femoral Head System Product Features and Instructions for Use. 2010.
- [7] R. Bruhn, C. Schaerer, N. Gronau and U. Wyss, 2010.
- [8] J. P. Heiney, S. Battula, G. A. Vrabec, A. Parikh, R. Blice, A. J. Schoenfeld et al., Impact magnitudes applied by surgeons and their importance when applying the femoral head onto the Morse taper for total hip arthroplasty. *Arch. Orthop. Trauma Surg*, 2009. 129: p. 793-796.
- [9] M. L. Mroczkowski, J. S. Hertzler, S. M. Humphrey, T. Johnson, C. R. Blanchard, Effect of impact assembly on the fretting corrosion of modular hip tapers. *Journal of Orthopaedic Research*, 2006. 24: p. 271-279.
- [10] Annelie Rehmer, N. E. Bishop, Michael M. Morlock, Influence of assembly procedure and material combination on the strength of the taper connection at the head-neck junction of modular hip endoprostheses. *Clinical Biomechanics*, 2012. 27: p. 77-83.
- [11] A.T. Pennock, A.H.S., C.A. Bourgeault, Morse-type tapers—factors that may influence taper strength during total hip arthroplasty. *Journal of Arthroplast*, 2002. 17: p. 773-778.

Obinna K. Ihesiulor is presently a PhD student at the University of New South Wales, Canberra, Australia. He obtained his Master's degree in 2012 at the same university. His current research interest is in the area of prosthetic devices for joint replacements. His PhD research work is on the investigation of wear of total hip replacement at the taper-trunnion junction. In order to quantify the amount of material loss to ultimate locations in the surrounding joint space, the taper-trunnion project for wear investigation is conceptualized and motivated. In a broader sense, the principal goal is to work toward the minimization of wear debris produced in the hip joint, thereby resulting in a longer prosthetic lifetime.