

Up Scaling of Highly Transparent Quasi-Solid State, Dye-Sensitized Solar Devices Composed of Nanocomposite Materials

Dimitra Sygkridou, Andreas Rapsomanikis, Elias Stathatos, Polycarpos Falaras, Evangelos Vitoratos

Abstract—At the present work, highly transparent strip type quasi-solid state dye-sensitized solar cells (DSSCs) were fabricated through inkjet printing using nanocomposite TiO₂ inks as raw materials and tested under outdoor illumination conditions. The cells, which can be considered as the structural units of large area modules, were fully characterized electrically and electrochemically and after the evaluation of the received results a large area DSSC module was manufactured. The module design was a sandwich Z-interconnection where the working electrode is deposited on one conductive glass and the counter electrode on a second glass. Silver current collective fingers were printed on the conductive glasses to make the internal electrical connections and the adjacent cells were connected in series and finally insulated using a UV curing resin to protect them from the corrosive (I⁻/I₃⁻) redox couple of the electrolyte. Finally, outdoor tests were carried out to the fabricated dye-sensitized solar module and its performance data were collected and assessed.

Keywords—Dye-sensitized solar devices, inkjet printing, quasi-solid state electrolyte, transparency, up scaling.

I. INTRODUCTION

THE gradual depletion, the cost increase and the environmental impact of the fossil fuel has led to an increase in the investigation of renewable energies. Among them, solar energy may successfully meet the ever increasing energy demands and photovoltaics can assist towards this direction. Particularly, third generation solar cells, as dye-sensitized solar cells, have attracted intense interest over the past decades due to their simple and environmentally friendly fabrication procedures, low cost and the fact that it is possible to manufacture transparent cells that can be integrated as photovoltaic windows at building facades operating by front-face light incidence, but also by diffuse light and even by back face light incidence [1], [2].

Dimitra Sygkridou is with the Physics Department, University of Patras, 26500, Greece (e-mail: dsygridou@upatras.gr).

Andreas Rapsomanikis is with the Department of Geology, University of Patras, 26500, Greece (e-mail: rapsosan@gmail.com).

Elias Stathatos is with the Electrical Engineering Department, Technological-Educational Institute of Western Greece, 26334 Patras, Greece (Corresponding author, phone: 0030-2610-369242; e-mail: estathatos@teiwest.gr).

Polycarpos Falaras is with the Institute Nanoscience and Nanotechnology (INN) National Center for Scientific Research "Demokritos" 153 10 Aghia Paraskevi Attikis, Athens, Greece (e-mail: p.falaras@inn.demokritos.gr).

Evangelos Vitoratos is with the Physics Department, University of Patras, 26500, Greece (Corresponding author, phone: 0030-2610-997487; E-mail: vitorato@physics.upatras.gr).

The long term goal and the motivation to go from the laboratory scale to large area dye sensitized solar devices, which would also lead to their commercialization and to an industrially mass production, is to reach a satisfactory efficiency and an increased life expectancy. By now their efficiency has reached an almost 13% overall performance for small sized cells and there is even more room for improvement [3]. Over the past years, research groups have attempted manufacturing large area dye-sensitized solar modules, trying to overcome the difficulties that they come across which will lead to the fabrication of an optimized device [4]-[7].

In this work, we started by investigating the effect of the varying length of strip shaped dye-sensitized solar cells, employing a quasi-solid state electrolyte, to their electrical parameters, since strips can be considered as the structural units of large area devices. Electrodes, photoanode and counter electrode were fabricated through inkjet printing ensuring uniformity of the samples. Firstly, the basic individual components of a cell were studied. In particular, the cells' photoanode was structurally characterized and the electrolyte was subjected to thermal treatment. Secondly, the strips were characterized electrically and electrochemically and after evaluating the obtained results we proceeded with the up-scaling, fabricating a sandwich module sized 24.5 cm x 21 cm with an active area of 253 cm² consisting of serially connected strips. Silver collecting grid was also printed on the conductive glass for an efficient current collection.

II. MATERIALS AND METHODOLOGY

A. Materials

Commercially available lithium iodide, iodine, 1-methyl-3-propylimidazolium iodide, tert-butyl pyridine, guanidine thiocyanate, chloroplatinic acid hexahydrate (H₂PtCl₆), O, O'-Bis(2-aminopropyl) polypropylene glycol-block-polyethylene glycol-block-polypropylene glycol (Jeffamine® ED-600), 3-isocyanatopropyltriethoxysilane and all solvents were purchased from Sigma-Aldrich and used as received: 3 - *Cis*-diisothiocyanato - bis (2,2'-bipyridyl-4,4'- dicarboxylato) ruthenium(II) bis(tetrabutylammonium), N719 was purchased from Solaronix S.A, Switzerland. SnO₂: F transparent conductive electrodes (FTO, TECTM A10) 10 Ohm/square were purchased from Pilkington NSG Group. UV cured resin Dymax 429 gel was used to cover silver grids inkjet printed on FTO glasses using Cabot silver ink. Commercial ultra-pure

titanium butoxide (TTBU, 97%, Aldrich), Triton X-100 (polyethylene glycol p-tert-octylphenyl ether) surfactant (99.8%, Fisher Scientific), glacial acetic acid (AcOH, Aldrich) were used to make precursor TiO₂ sols.

B. Preparation of TiO₂ Nanostructured Photoanodes Sensitized With Dye and of Platinum Counter Electrode

TiO₂ transparent thin films were fabricated via the sol-gel method following a previously reported procedure [8]. Briefly, for 5.4 ml solution, 0.72 g of Triton X-100 was mixed with 4 ml of ethanol, followed by addition of 0.4 ml of glacial acetic acid and 0.37 ml of titanium butoxide under vigorous stirring. After a few minutes stirring, the solution was deposited on the FTO glasses with inkjet printing (Dimatix Materials Printer DMP-5000). The films were heated up to 500°C for 30 minutes using 20°C/min heating ramp rate. This procedure, of sequential printing and sintering steps, was repeated several times until the TiO₂ thickness was approximately 2 μm. Finally the TiO₂ films were immersed in an ethanol/acetonitrile (1/1 v/v) solution of N719 (the dye concentration was 4*10⁻⁴ M) in order to sensitize the TiO₂ electrode in the visible. Excessive dye molecules that weren't adsorbed on the TiO₂ surface were removed by rinsing with acetonitrile. The platinized FTO glasses were made by inkjet printing of a H₂PtCl₆ solution (5 mg/1 ml of n-propanol) followed by heating at 500°C for 10 minutes.

C. Quasi-Solid Electrolyte Preparation

In the construction of the solar cells a quasi-solid state electrolyte was used. This was chosen as a promising approach to DSSC technology as it combines the high ionic conductivity of liquids while it reduces the risk of leaks and minimizes sealing problems in the cells. For the gel electrolyte applied to the DSSCs, we used a hybrid organic-inorganic material [9], [10]. Briefly, O, O'-Bis(2-aminopropyl) polypropylene glycol-block-polyethylene glycol-block-polypropylene glycol (Jeffamine® ED-600), of molecular weight 600 and 3-isocyanatopropyltriethoxysilane (ICS; molar ratio ICS/diamine=2) react in a vessel (acylation reaction), producing urea connecting groups between the polymer units and the inorganic part. The gel electrolyte was synthesized by the following procedure: 0.0788 g of the functionalized alkoxide precursor (ED600-ICS) was dissolved in 0.2 g of sulfolane and 0.1 g of methoxypropionitrile under vigorous stirring. Then, 0.046 g AcOH were added followed by 0.015 g 1-methyl-3-propylimidazolium iodide, 0.015 g LiI and 0.0075 g I₂. Finally, the electrolyte solution was completed by adding 0.0255 g tert-butyl pyridine and 0.00445 g guanidine thiocyanate. After a few minutes of stirring, one drop of the obtained sol was placed on the top of the titania electrode with adsorbed dye molecules and a slightly platinized FTO counter electrode was pushed by hand on the top. The two electrodes tightly stuck together by Si-O-Si bonds developed by the presence of the hybrid material.

D. Fabrication of Strip Shaped Dye-Sensitized Solar Cells and Up-Scaling

Before transitioning to the fabrication of large area modules we fabricated and tested strip shaped dye-sensitized solar cells with constant width of 1 cm and variable length from 1 to 25 cm, as the strips can be considered to be the structural units for big size solar cells and modules. A visual appearance of the proposed cells can be seen in Fig. 1. After evaluating the results of the strip shaped DSSCs, we proceeded with the fabrication of dye-sensitized solar modules using a sandwich Z-interconnection where the working electrode is deposited on one glass and the counter electrode on a second glass. A silver paste was printed on the glasses to make the internal electrical connections and serially connect the adjacent cells. After the deposition of the silver wires the glasses were sintered at 400°C for 10 minutes. A UV curing resin was used to insulate the silver wires to avoid their corrosion from the electrolyte.

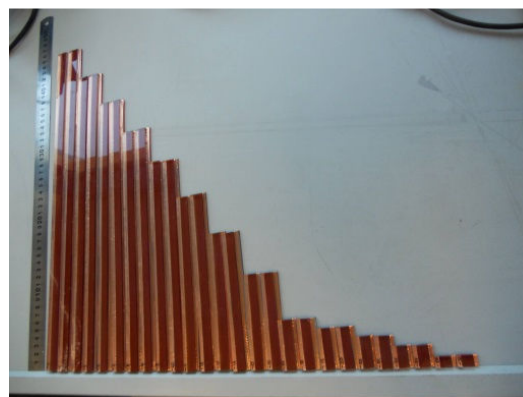

Fig. 1 Strip shaped DSSCs with variable length from 1 to 26 cm and constant 1 cm width

E. Characterization Techniques

The photoanode and the electrolyte were characterized separately before characterizing the complete cell. Firstly, the structural properties of the TiO₂ films were investigated through nitrogen sorption-desorption analysis using Micromeritics Tristar 3000 and the surface area, porosity, and pore size distribution were derived by differentiating them according to BET method. Secondly, the materials responsible for the jellification of the electrolyte, namely the hybrid organic-inorganic material and the acetic acid were diluted in the electrolyte solvents, sulfolane and 3-methoxypropionitrile, under vigorous stirring and the solution was left in an open bottle to speed up its solidification. The formed gel was used to perform thermal gravimetric analysis (TGA) measurements using a Perkin Elmer Simultaneous Thermal Analyzer STA6000 controlled by Pyris Manager Software. The measurements were carried out from a temperature of 15°C to 440°C.

For the J-V curves, the cells were subjected to outdoor solar irradiation. The light intensity was almost constant at 950 W/m² during all experiments and measured with a Newport power meter (Model 843-R). Finally, the J-V plots were recorded by connecting the devices to a Keithley Source Meter

(model 2420) which was controlled by Keithley computer software (LabTracer). The cells' total active area varied from 1 cm x 1 cm to 1 cm x 25 cm. For each case, we made two devices which were tested under the same conditions in order to avoid any misleading estimation of their efficiency. Cell performance parameters, including short-circuit current density (J_{SC}), open circuit voltage (V_{OC}), maximum power (P_{max}), fill factor (FF) and overall cell conversion efficiency, were measured and calculated from each J-V characteristic curve.

Electrochemical impedance spectroscopy measurements (EIS) were also carried out under outdoor illumination at some strip cells with indicative length. EIS measurements were performed with Metrohm Autolab 3.v potentiostat galvanostat (Model PGSTAT 128N) through a frequency range of 100 kHz-0.01 Hz using a perturbation of ± 10 mV over the open circuit potential. Experimental data are presented by scattering symbols while lines represent the fitted plots obtained using Nova 1.10 software.

III. RESULTS AND DISCUSSION

A. Photoanode Characterization

The measurement for the porosity of the TiO_2 film was carried out on powder which resulted by scratching thick films made on glass microscope slides and grinding the obtained flakes to break all agglomerations. The sample was degassed for 2h at $100^\circ C$ before N_2 sorption analysis. The particle surface area and pore structure of the TiO_2 powder are summarized in Table I, while the results are presented in Fig. 2. The hysteresis loop in Fig. 2 appears at low relative pressure ($0.4 < P/P_0 < 0.8$) which is attributed to smaller mesoporosity of the material. The sample's Brunauer, Emmett and Teller (BET) specific surface area was high while the Barrett, Joyner and Halenda (BJH) pore volume was relatively low. Moreover, the TiO_2 sample had a small mean pore diameter. In addition, based on SEM cross section image (Fig. 3 (a)), the film was thin highly homogeneous without cracks and the desirable thickness of $2 \mu m$ was achieved. Besides, the film is consisted of very small nanoparticles of spherical shape with an average diameter of ~ 10 nm. The particles appear in a dense agglomerated form but any of them was very small.

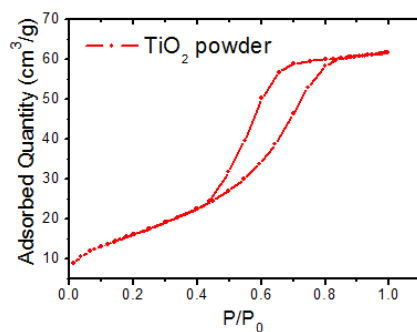

Fig. 2 Sorption-desorption isotherm of TiO_2 powder

B. Electrolyte Characterization

The solution used for the thermal gravimetric analysis was composed by sulfolane, 3-methoxypropionitrile, the hybrid organic-inorganic material and acetic acid for the solvolysis. The bottle containing the solution was left without a cap to expedite the gelation process and the measurements were carried out using the resulting gel.

TABLE I
 STRUCTURAL PROPERTIES OF TiO_2 POWDER

Sample	Porosity (%)	S_{BET} (m^2/g)	Pore diameter (nm)	Pore volume (cm^3/g)	Pore width (nm)
TiO_2 powder	26.51	60.46	4.45	0.095	6.31

From the thermal gravimetric analysis curve (Fig. 4) the weight of the gel started to be slightly reduced after $50^\circ C$. The fact that the weight starts to be reduced at a temperature lower than $100^\circ C$ probably is an indication of water presence in the sample [11]. The weight loss increased significantly in the temperature range of $150^\circ C$ - $250^\circ C$ probably because of the evaporation of the gel's solvents.

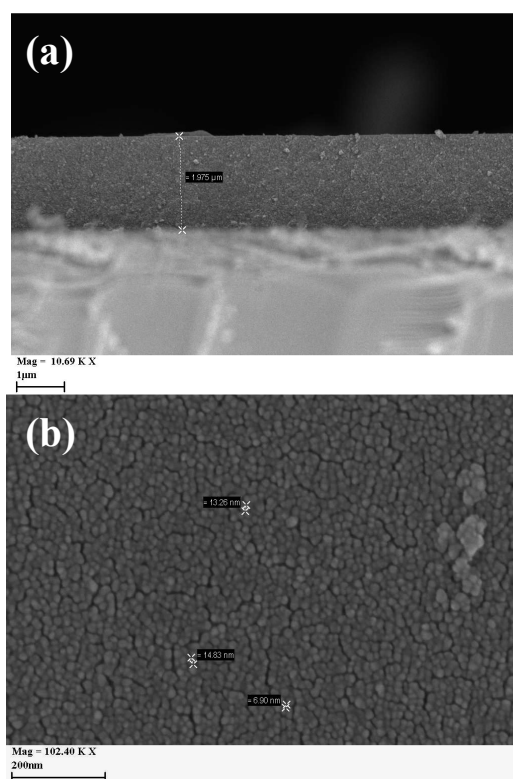

Fig. 3 (a) Cross section of the TiO_2 film with an average thickness of $2 \mu m$ and (b) image of the surface of the film consisted of nanoparticles with average size 10 nm

C. Solar Cells' Performance

Figs. 5 (a) and (b) present the current density-voltage (J-V) characteristic curves of the strips with the varying length. The electrical parameters measured and calculated for all cells are summarized in Table II.

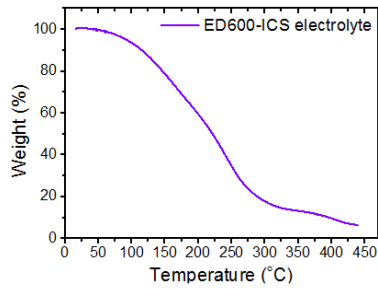

Fig. 4 TGA curves of the formed gel

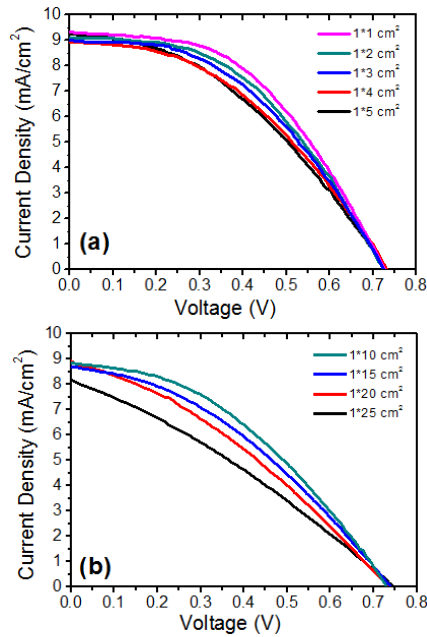

Fig. 5 Photocurrent density-voltage characteristic curves of dye-sensitized solar cells of length from (a) 1 to 5 cm and (b) from 10 to 25 cm

It can be seen that the short circuit current density values measured have small variations as the length increases from 1 to 25 cm. The V_{oc} values recorded for the cells with the different strip length had small variations as expected, since the same anode and electrolyte was used for manufacturing the cells. Variations were mainly noticed at the fill factor values calculated and as a result to the overall efficiency. This decrease is attributed to the fact that the size of the cell affects the FF due to the total internal in series resistance of the cell (R_s). Finally, we considered that a solar module with an almost square form and dimensions between 20 and 25 cm for each side could provide adequately satisfactory results.

D. Electrochemical Impedance Spectroscopy (EIS)

Fig. 6 shows the Nyquist plots obtained for some of the strip shaped cells. The first semicircle, starting from left to right, at the high frequency, corresponds to the charge transfer resistance of the Pt/electrolyte interface, R_{pt} . The resistance element related to the response in the intermediate frequency represents the charge transport at the TiO_2 /dye/electrolyte interface (R_{tr}) and shows diode like behavior. The semicircle at the low frequency, which is attributed to the diffusion of

redox species in the electrolyte (R_{dif}), was small and not well distinguished, indicating a fast diffusion. Finally, the intercept of the horizontal axis stands for the resistance of the sheet resistance of the FTO substrate and the contact resistance of the FTO/ TiO_2 (R_h) [12], [13].

TABLE II
 ELECTRICAL CHARACTERISTICS OF DSSCS OF VARIABLE LENGTH

Strip size (cm ²)	J_{sc} (mA/cm ²)	V_{oc} (V)	FF	n (%)
1x1	9.33	0.73	0.48	3.3
1x2	9.07	0.72	0.47	3.1
1x3	9.03	0.73	0.45	3.0
1x4	9.05	0.73	0.43	2.9
1x5	9.26	0.73	0.42	2.8
1x10	8.84	0.73	0.39	2.6
1x15	8.70	0.74	0.40	2.6
1x20	8.85	0.73	0.36	2.4
1x25	8.12	0.75	0.33	2.1

The total series resistance of the cell can be calculated using (1):

$$R_s = R_h + R_{pt} + R_{dif} \quad (1)$$

The equivalent circuits, which were used to fit the experimental data, are presented in Fig. 7. For electrodes having a rough surface the capacitance element in Fig. 7 (a) is replaced by a constant phase element (CPE, Q) which depends on the parameters Y_o and N (Fig. 7 (b)) [14]. According to instrument software's manual Y_o is the admittance of an ideal capacitance while N is an empirical constant ranging from 0 to 1. It is possible to convert a CPE element, which is in parallel with a resistance, to a pseudo capacitance using (2). As shown in (2) for $N=1$ the CPE element describes a pure capacitor, while for $N=0$ an ideal resistor.

$$C_{pseudo} = Y_o^{1/N} \cdot R \left(\frac{1}{N} - 1 \right) \quad (2)$$

Moreover, for $N=0.5$ the CPE element is equivalent to the Warburg element often used to describe the diffusion in the electrolyte.

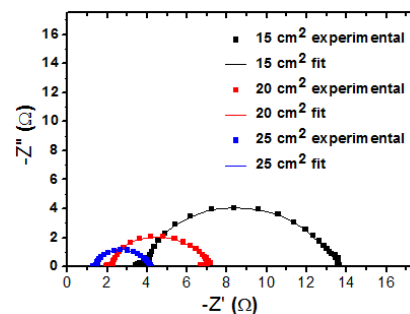

Fig. 6 Impedance spectra of dye-sensitized solar cells with varying length measured at open circuit voltage under outdoor illumination

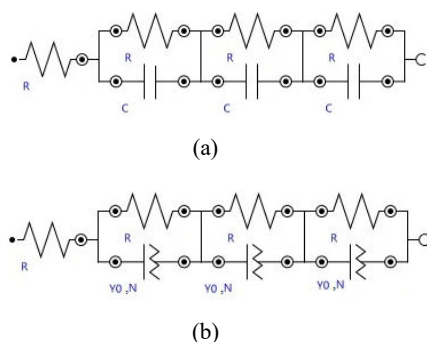

Fig. 7 DSSCs equivalent circuits (a) R(RC)(RC)(RC) and (b) R(RQ)(RQ)(RQ) used to fit the experimental data from the EIS measurements

It is generally thought to arise from the lack of homogeneities in the electrode-material system. The fitted parameters are summarized in Table III. Since the tested cells have different active area, due to their different length, it is not accurate to compare their total series resistance in Ω using (1). Thus, we decided to multiply the obtained values from (1) with the active area of each cell and derive a conclusion from the final values calculated in $\Omega \text{ cm}^2$.

TABLE III
ELECTROCHEMICAL IMPEDANCE SPECTROSCOPY FITTED PARAMETERS FOR STRIP SHAPED DSSCs WITH VARYING LENGTH

Strip size (cm ²)	R _h (Ω)	R _{pt} (Ω)	C _{pt} (F) (10 ⁻⁴)	R _{tr} (Ω)	C _{tr} (F) (10 ⁻³)	R _{dir} (Ω)	C _{dir} (F) (10 ⁻¹)
1x15	3.44	0.54	0.41	7.86	2.61	2.09	0.73
1x20	1.97	0.50	0.80	3.49	5.53	2.27	0.64
1x25	1.41	0.55	1.27	2.15	8.40	1.96	1.95

The values of R_S for the cells with strip length 15 cm, 20 cm and 25 cm were 91.05 $\Omega \text{ cm}^2$, 94.8 $\Omega \text{ cm}^2$ and 98 $\Omega \text{ cm}^2$ respectively. It can be seen from these values that the total series resistance didn't increase significantly as the length increased, which was very encouraging for the transition to large scale.

E. Dye-Sensitized Solar Module

A module employing optimized electrode width of 1 cm was realized on a 24.5 cm x 21 cm FTO plate consisting of nine independent solar cells serially connected by mechanical scribing of the FTO substrate to test the reliability of serial connection in DSSC scaling up (Fig. 8).

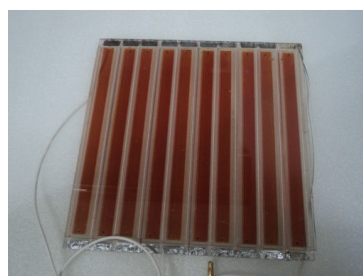

Fig. 8 A highly transparent 253 cm² DSSC module with 10 serially connected elements

The use of thin films of TiO₂ as described in the experimental section, low content Pt inkjet printed strips on the counter electrode and the low-surface density of N719 dye allow for a high transparency of the module.

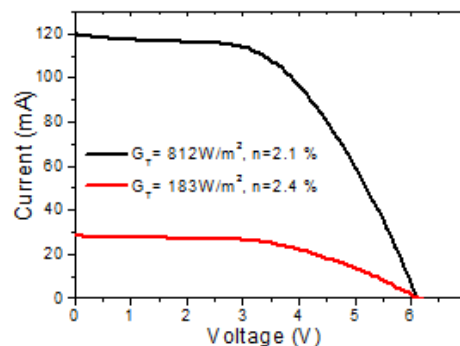

Fig. 9 Photocurrent density-voltage characteristic curves of dye-sensitized solar module of active area 253 cm²

High transparency and serial connection have demonstrated that the module I-V characteristics were almost independent from the light direction i.e. front or back illumination providing similar performances. The I-V curves of the module measured at two different light intensities (183 and 812 Wm⁻²) are presented in Fig. 9. As it can be seen, there are no serious differences among the efficiencies obtained for 1x20cm² strip type DSSC cell and the 253 cm² module.

IV. CONCLUSIONS

At the present work we prepared DSSCs at different sizes varying their length by keeping constant their width at 0.5 cm. The cells were constructed with thin nanocrystalline TiO₂ films made with inkjet process using appropriate sols. We have shown that the serial connection of individual cells with a suitably chosen size to encompass a simple electrode pattern while keeping current losses at minimum values, was demonstrated to be a successful approach. The use of gel electrolytes in such geometry was possible employing low sheet resistance FTO glass, a thin film of TiO₂ and a low dye concentration that allowed dye regeneration not to be limited by slow electrolyte diffusion processes. The gel electrolyte DSSCs realized reached an almost 2.5% efficiency. Stability issues can be addressed by the use of gel electrolytes, which avoids leakage problems and leads to a stable shelf life.

ACKNOWLEDGMENTS

This research has been co-financed by the European Union (European Social Fund-ESF) and Greek national funds through the Operational Program "Education and Lifelong Learning" of the National Strategic Reference Framework (NSRF) - Research Funding Program: ARCHIMEDES III, Investing in knowledge society through the European Social Fund.

REFERENCES

- [1] M. Späth, P. M. Sommeling, J. A. M. Van Roosmalen, H. J. P. Smit, N. P. G. van der Burg, D. R. Mahieu, N. J. Bakker, J. M. Kroon, "Reproducible Manufacturing of Dye-Sensitized Solar Cells on a Semi-Automated Baseline", *Progress in Photovoltaics: Research and Applications*, vol. 11, pp. 207-220, February 2003.
- [2] F. E. Gálvez, E. Kempainen, H. Míguez and J. Halme, "Effect of Diffuse Light Scattering Designs on the Efficiency of Dye Solar Cells: An Integral Optical and Electrical Description", *J. Phys. Chem. C*, vol. 116, pp. 11426-11433, May 2012.
- [3] S. Mathew, A. Yella, P. Gao, R. Humphry-Baker, B. F. E. Curchod, N. Ashari-Astani, I. Tavernelli, U. Rothlisberger, Md. K. Nazeeruddin, M. Grätzel, "Dye-Sensitized Solar Cells with 13% Efficiency Achieved through the Molecular Engineering of Porphyrin Sensitizers", *Nature Chemistry*, vol. 6, pp. 242-247, February 2014.
- [4] J. Goldstein, I. Yakypov, B. Breen, "Development of Large Area Photovoltaic Dye Cells at 3GSolar", *Solar Energy Materials and Solar cells*, vol. 94, pp/ 638-641, April 2010.
- [5] G. R. A. Kumara, S. Kawasaki, P. V. V. Jayaweera, E. V. A. Premalal, S. Kaneko, "Large Area Dye-Sensitized Solar Cells with Titanium based Counter Electrode", *Thin Solid Films*, vol. 520, pp. 4119-4121, April 2011.
- [6] "Fabrication and Characterization of Interconnected Grip-type Dye-Sensitized Solar Modules", *Int. J. Electrochem. Sci.*, vol. 7, pp. 11904-11916, December 2012.
- [7] "Design Methods for Large Scale Dye-Sensitized Solar Modules and the Progress of Stability Research", *Renewable and Sustainable Energy Reviews*, vol. 14, pp. 3178-3184, June 2010.
- [8] E. Stathatos, P. Lianos, A. Surca Vuk, B. Orel, "Optimization of a Quasi-Solid-State Dye-Sensitized Photoelectrochemical Solar Cell Employing a Ureasil/Sulfolane Gel Electrolyte", *Adv. Funct. Mater.*, vol. 14, pp. 45-48, January 2004.
- [9] E. Stathatos, "Organic-Inorganic Nanocomposite Materials Prepared by the Sol-Gel Route as New Ionic Conductors in Quasi Solid State Electrolytes", *Ionics*, vol. 11, pp. 140-145, November 2004.
- [10] E. Stathatos, P. Lianos, U. L. Stangar, B. Orel, and P. Judeinstein, "Structural Study of Hybrid Organic/Inorganic Polymer Gels Using Time-Resolved Fluorescence Probing", *Langmuir*, vol. 16, pp. 8672-8676, June 2000.
- [11] J. E. Benedetti, F. S. Freitas, F. C. Fernandes, A. S. Gonçalves, A. Magalhães, A. F. Nogueira, "Investigation of the Structural Properties of Poly(Ethylene Oxide) Copolymer as Gel Polymer Electrolyte and Durability Test in Dye-Sensitized Solar Cells", *Ionics*, vol. 21, pp. 1771-1780, December 2014.
- [12] F. Fabregat-Santiago, G. Garcia-Belmonte, I. Mora-Seró, J. Bisquert, "Characterization of Nanostructured Hybrid and Organic Solar Cells by Impedance Spectroscopy", *Phys. Chem. Chem. Phys.*, vol. 13, pp. 9083-9118, March 2011.
- [13] Q. Wang, J.-E. Moser, M. Grätzel, "Electrochemical Impedance Spectroscopic Analysis of Dye-Sensitized Solar Cells", *J. Phys. Chem. B*, vol. 109, pp. 14945-14953, July 2005.
- [14] E. Barsoukov, J. R. Macdonald, "Impedance Spectroscopy Theory, Experiment, and Applications", Wiley- Interscience, pp.65, 79, April 2005.

Dimitra Sygkridou received her diploma in Electrical and Computer Engineering from the University of Patras, Greece in 2010 and her M.Sc in Environmental Sciences from same university in 2013. She is a PhD candidate at the Department of Physics, University of Patras since 2013. Dimitra Sygkridou has published her research in peer reviewed scientific journals and international conferences. Her field of research focuses on third generation photovoltaics, materials science and building integration of photovoltaics. She is also a member of the Technical Chamber of Greece since 2010.

Andreas Rapsomanikis is an Electrical engineer from Technological Institute of Western Greece since 2013, who currently works at Nanotechnology and Advanced materials laboratory at Technological Institute of Western Greece. He is an M.Sc candidate at the Department of Geology, University of Patras studying Environmental Sciences. Andreas Rapsomanikis has published his research in peer reviewed scientific journals. His field of research includes dye-sensitized solar cells, photocatalytic applications, electrochromic devices, and perovskite solar cells.

Elias Stathatos was born in 1968 in Patras, Greece. He obtained his first degree in Physics from University of Patras and then his Ph.D. degree from Engineering Science Department also in University of Patras. Prof. Stathatos was a postdoctoral research fellow in University of Cincinnati, USA at the Civil & Environmental Engineering Dept. Professor Stathatos is the head of the Nanotechnology and Advanced materials laboratory and he has more than 100 publications in peer review journals and five chapters in books which are recognized of more than 3600 citations (h -factor=31). He is an editorial board member for Journal of Advanced Oxidation Technologies, Materials science in semiconductor processing, Heliyon and international Journal of Photoenergy.

Polycarpus Falaras was born in Karditsa, Greece (1960). Following his basic studies in Physics at the Aristotle University of Thessaloniki (Greece), Dr. Falaras joined the Physique des Liquides et Electrochimie Laboratory/CNRS/University Pierre et Marie Curie (Paris VI-France), where he received his DEA in Electrochemistry (1983) and Ph.D. in Chemistry (1986, Tres Honorable). In 1989 he entered the Institute of Physical Chemistry at the National Center for Scientific Research 'Demokritos' in Athens (Greece), where he is still working as a Research Director, leading a group of 16 people. He disposes strong expertise in Research Management, he has been the Director of the Institute of Physical Chemistry at NCSR Demokritos (2007-2012), member of the board of Directors of NCSR Demokritos (2004-2012), member of the board of Directors of EBETAM S.A., member of the Scientific Council of the National Center of Documentation (Greece, 2006-2010) and National representative to ESFRI and expert to EFSA. He has more than 200 publications in peer review journals which are recognized of more than 5000 citations (h -factor=39).

Evangelos Vitoratos is currently member of condensed materials section in Physics department at the University of Patras. His research interests include Electronic Transport properties in solids (Conducting polymers - semiconductors) and Materials for Organic Electronics. He has more than 60 publications in peer review journals which are recognized of more than 700 citations (h -factor=13).