

Design of Power System Stabilizer with Neuro-Fuzzy UPFC Controller

U. Ramesh Babu, V. Vijay Kumar Reddy, S. Tara Kalyani

Abstract—The growth in the demand of electrical energy is leading to load on the Power system which increases the occurrence of frequent oscillations in the system. The reason for the oscillations is due to the lack of damping torque which is required to dominate the disturbances of Power system. By using FACTS devices, such as Unified Power Flow Controller (UPFC) can control power flow, reduce sub-synchronous resonances and increase transient stability. Hence, UPFC is used to damp the oscillations occurred in Power system. This research focuses on adapting the neuro fuzzy controller for the UPFC design by connecting the infinite bus (SMIB - Single machine Infinite Bus) to a linearized model of synchronous machine (Heffron-Phillips) in the power system. This model gains the capability to improve the transient stability and to damp the oscillations of the system.

Keywords—Power System, UPFC, (ANFIS) Adaptive Neuro Fuzzy Inference System, transient, Low frequency oscillations.

I. INTRODUCTION

DUE to the advancements in technology and industrial growth, today's power system has become a highly complex in nature. It is essential to improve the power transfer limits and the stability limits of the existing Power system lines for the effective implantation of these policies to overcome the constraints imposed by the cost of construction, right of way issues and environmental factor.

Unified Power Flow Controller (UPFC) is power electronics based system that can provide the control of the Power system line impedance, phase angle and reactive power [1]. This versatility of the UPFC makes it a prime FACTS device that can provide many of the control functions required to solve a wide range of dynamic and Steady state problems encountered in power systems [2]-[4]. Conventional fixed structure power system stabilizers (CPSS) are widely used by power system utilities to damp out small oscillations [5], [6]. The parameters of the power system stabilizer (PSS) must be re-tuned so that it can provide the desired performance. Self-tuning PSS have been proposed to overcome such problem [7]. Such as Artificial Neural Network (ANN), Fuzzy Logic Systems (FLC) and Genetic Algorithms (GA) have been applied to various power system problems including PSS design [8]-[10]. By designing a suitable UPFC controller, an effective damping control is achieved. It is usual that Heffron-

U.Ramesh Babu is with the Electrical Engineering Department, Neduramalli Balakrishna Reddy Institute of Science and Technology, Andhra Pradesh, India (phone: 91-9949360473; e-mail: uramesh25@gmail.com).

V. Vijaya Kumar Reddy is with the Neduramalli Balakrishna Reddy Institute of Science and Technology, Andhra Pradesh, India.

S. Tara kalyani is with the Electrical Engineering Department, JNTUH, Telangana, India.

Phillips model is used in power system to study small signal stability.

II. SYSTEM MODEL

In this Section, Power system consists of UPFC as shown in Fig 1. A Single Machine Infinite Bus (SMIB) system with synchronous generator provided with IEEE type-ST1A excitation system is considered. It is assumed that the UPFC performance is based on Pulse Width Modulation (PWM) converters. Here m_1, m_2 are the amplitude modulation ratio and δ_1, δ_2 are the phase angles of the reference voltage of each voltage source converter respectively. The nominal operating conditions and system parameters are given in appendix

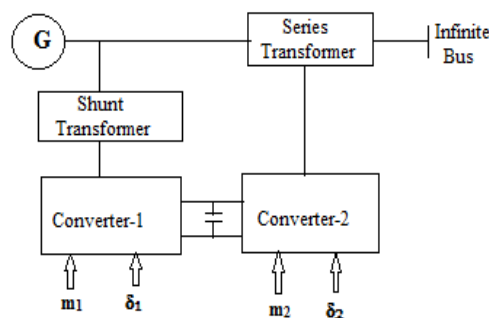

Fig. 1 UPFC connected to SMIB

The basic components of UPFC are two voltage source inverters (VSIs) sharing a common dc storage capacitor which is connected to the power system through coupling transformers. One of the VSI is connected to power system via a shunt transformer, while the other one is connected in series through a series transformer. A basic UPFC functional diagram is shown in Fig. 1.

The series inverter is operated to inject a symmetrical three phase voltage system (V_{sc}), of controllable magnitude and phase angle in series with the line to control active and reactive power flows on the power system. So, this inverter will exchange active and reactive power with the line.

The shunt inverter is operated in such a way that it demands the dc terminal power (positive or negative) from the line keeping the voltage across the storage capacitor V_{dc} constant. So, the net real power absorbed from the line by the UPFC is equal only to the losses of the inverters and their transformers. The remaining capacity of the shunt inverter can be used to exchange reactive power with the line so as to provide the voltage regulation at the connection point.

The two VSI's can work independently of each other by separating the dc side. In this case the shunt inverter is

operates as a STATCOM that generates or absorbs reactive power to regulate the voltage magnitude at the connection point. On the other hand the series inverter is operates as SSSC that generates or absorbs reactive power to regulate the current flow, and hence the power flow on the Power system.

The UPFC has many possible operating modes. In particular, the shunt inverter operates in such a way that it injects a controllable current, I_{sh} into the transmission line. The shunt inverter can be controlled in two different modes.

A. VAR Control Mode

The reference input is an inductive or capacitive VAR request. The shunt inverter control translates the var reference into a corresponding shunt current request and adjusts gating of the inverter to establish the desired current. For this mode of control a feedback signal representing the dc bus voltage, V_{dc} , is also required.

B. Automatic Voltage Control Mode

The shunt inverter reactive current is automatically regulated to maintain the transmission line voltage at the point of connection to a reference value. For this mode of control, voltage feedback signals are obtained from the sending end bus feeding the shunt coupling transformer.

C. Direct Voltage Injection Mode

The reference inputs are directly the magnitude and phase angle of the series voltage. The series inverter controls the magnitude and angle of the voltage injected in series with the line to influence the power flow on the line. The actual value of the injected voltage can be obtained in several ways.

D. Phase Angle Shifter Emulation Mode

The reference input is phase displacement between the sending end voltage and the receiving end voltage.

E. Line Impedance Emulation mode:

The reference input is an impedance value to insert in series with the line impedance.

F. Automatic Power Flow Control Mode

The reference inputs are values of P and Q to maintain on the transmission line despite system changes.

III. LEAD LAG CONTROLLER

Low frequency oscillations occur frequently due to disturbances such as changes in loading conditions or a loss of a transmission line or a generator unit. These conditions need to be controlled to maintain system stability. Several control devices, such as power system stabilizers, are used to enhance power system stability. Recently, it has shown that oscillations can be damped by introducing a supplementary signal, based on the real power flow along the transmission line, to the series converter side through the modulation of the active power flow reference sign the damping controllers used so far were of lead-lag type with the transfer function similar to the one shown in Fig. 2.

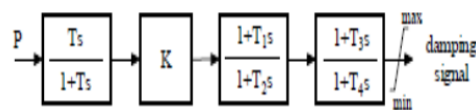

Fig. 2 Lead lag controllers

IV. ANFIS

Fig. 3 shows the architecture of a typical ANFIS (Adaptive Neuro Fuzzy Inference System) with two inputs 1 and 2 and one output f, 18 if-then rules for the first order Sugeno fuzzy model, where each input is assumed to have 18 associated membership functions (MFs) shown in Fig. 4. For a first-order Sugeno fuzzy model a typical rule set with two fuzzy if-then rules can be expressed as [11]-[14].

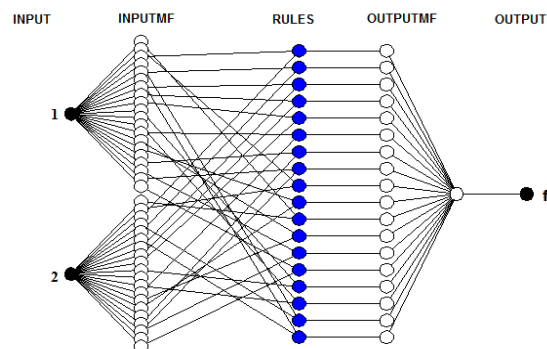

Fig. 3 ANFIS structure

Rule (1). If input1 is A1 and input2 is B1, then $f_1 = m_1 \text{input}_1 + n_1 \text{input}_2 + q_1$,

Rule (2). If input1 is A2 and input2 is B2, then $f_2 = m_2 \text{input}_1 + n_2 \text{input}_2 + q_2$.

Output function parameters are m_1, n_1, q_1 and m_2, n_2, q_2

Both the premise (non-linear) and consequent (linear) parameters of the ANFIS should be tuned, based on the learning process, to optimally represent the factual mathematical relationship between the input space and output space. Normally, as a first step, an approximate fuzzy model is initiated by the system and then improved through an iterative adaptive learning process. ANFIS model basically takes the initial fuzzy model and tunes it by means of a hybrid technique combining i.e. gradient descent back propagation and mean least-squares optimization algorithms.

Because a neuro-fuzzy system is based on linguistic rules, by integrating prior knowledge into the system shorten the learning process. One of the popular integrated systems is an ANFIS, which is an integration of a fuzzy inference system with a back-propagation algorithm [15]. These adaptive techniques can be used to customize the membership functions so that the fuzzy logic controller best models the data. The fuzzy inference system (FIS) based on neuro-adaptive learning techniques is termed adaptive neuro-fuzzy inference system

In order for an FIS to be mature and well established so that it can work appropriately in prediction mode, its initial structure and parameters (linear and non-linear) need to be tuned or adapted through a learning process using a sufficient

input-output pattern of data [16]

One of the most commonly used learning systems for adapting the linear and nonlinear parameters of an FIS, particularly the first order Sugeno fuzzy model is the ANFIS. ANFIS is a class of adaptive networks that are functionally equivalent to fuzzy inference systems [12].

One of the advantages of using neuro-fuzzy controller is that we can utilize one of the designed controllers for instance Δm_1 controller in place of the other controllers. While if we use conventional lead-lag controller, for each controls parameters, a controller must be designed.

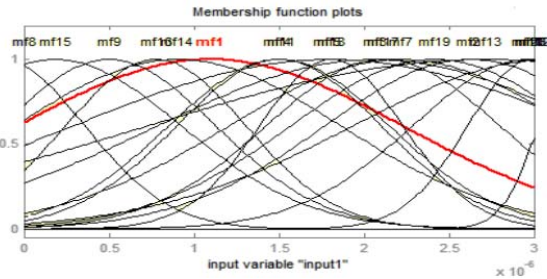

Fig. 4 The membership functions for input variable

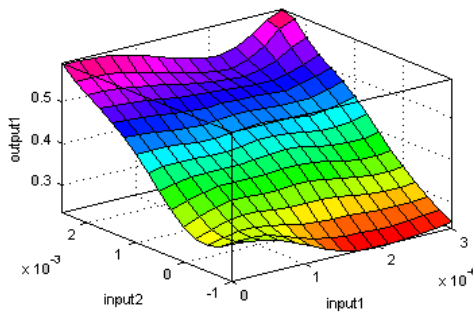

Fig. 5 The rule surface view

The output of fuzzy controller versus inputs is depicted in Fig. 5. As it can be seen that the rules surface is smooth and is desirable in design procedure

V. RESULTS AND DISCUSSIONS

According to the above analysis, the Power system UPFC is simulated by direct control to the Low frequency oscillations for different type of loads in the environment of MATLAB/SIMULINK. In this study, two steps are observed with the change in mechanical power. First step is deviation in rotor angle and the second one is voltage change. The basic parameters are shown in appendix. Simulation results for the system including comparison of Neuro fuzzy controller with traditional lead-lag controller is shown in Figs. 6-11. From the results, Neuro fuzzy controller is good when compared to traditional lead lag controller response and also reduction of peak overshoot is observed with Neuro fuzzy. Consequently, simulation results show that Neuro fuzzy controller efficiently increases the damping rate and decreases the amplitude of transients.

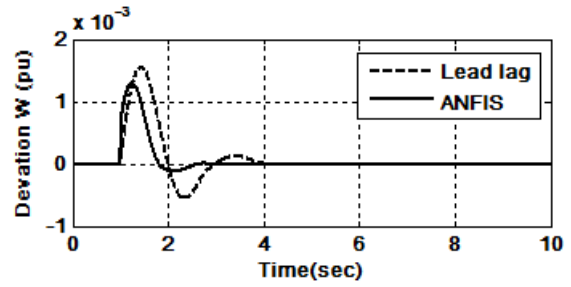

Fig. 6 Angular Velocity deviations during step change in Mechanical input power for nominal load (m_1 controller)

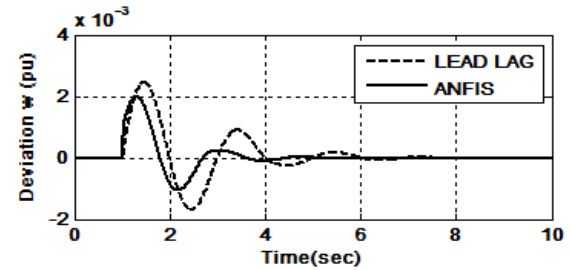

Fig. 7 Angular Velocity deviations during step change in Mechanical input power for light load (m_1 controller)

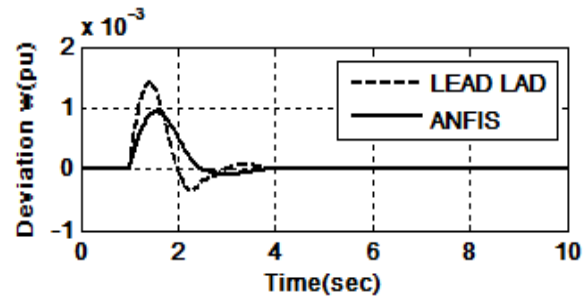

Fig. 8 Angular Velocity deviations during step change in Mechanical input power for nominal load (δ_1 controller)

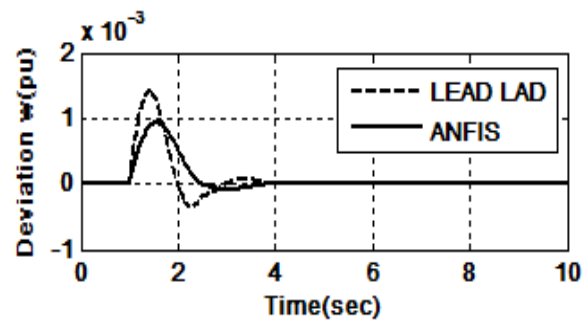

Fig. 9 Angular Velocity deviations during step change in Mechanical input power for nominal load (m_2 controller)

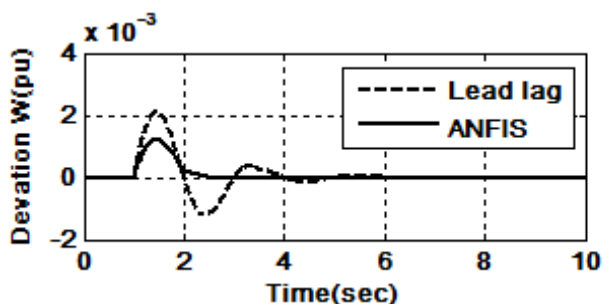

Fig. 10 Angular Velocity deviations during step change in Mechanical input power for nominal load (δ_2 controller)

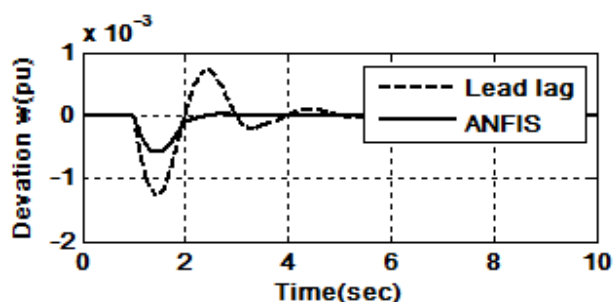

Fig. 11 Response of Angular Velocity for 5% step change in reference voltage in the case of nominal load (δ_2 controller)

VI. CONCLUSION

The proposed power system stabilizer based on the Neuro fuzzy Controller is effective in damping power oscillations and increases transient stability. Simulation results have shown that, controller exhibits good damping characteristics for different operating conditions and shows superior performance when compared to the conventional controller.

APPENDIX

A. Generator:

$$M=2H=8.0/MVA, D=0.0, T_{d0}'=5.044s$$

$$X_d=1.0pu, X_q=0.6pu, X_d'=0.3pu$$

B. Exciter (IEEE Type ST1):

$$K_A=100, T_A=0.01s$$

C. Reactances:

$$X_{IE}=0.1pu, X_E=X_B=1.0pu, X_{BV}=0.3pu, X_c=0.5pu$$

D. Operation Condition:

$$P_e=0.8pu, V_t=1pu, V_b=1pu$$

E. UPFC Parameters:

$$m_E=0.4013, m_B=0.0789, \delta_1=-85.3478, \delta_2=-78.2178$$

F. DC Link:

$$V_{dc}=2pu, C_{dc}=1pu$$

REFERENCES

[1] Gyugyl, "The Unified Power Flow Controller. A New Approach to Power Transmission Control", IEEE Trans on Power Deliv, Vol. 10, No.2, April 1995, pp.1085-1093.

[2] CD. Schauder, L. Gyugyl, M R Lund, D.M. Hamal, T R. Rletman. D. RTorgerson, and A Edns, "Operation of the Unified Power Flow Controller (UPFC) under Practical Constraints", IEEE Trans. On Power Delivery, Vol 13, No.2, Aprd 1998, pp 630-639.

[3] S. Limyingchal-oen, U, D. Annakkage, and NC. Pahalawaththa, "Effects of Unified Power Flow Controllers on Transient Stability", IEEE Proc - GenerTrfm.rn Distrib, Vol. 145, No.2, March 1998, pp 182-188.

[4] Y. Morloka. M. Kate, Y. Mlshlma, and Y. Nakachi, "Implementation of Undied Power Flow Controller and Verdicatlon for Transmm.lion Capablilty Impl-ovement", IEEE Trans on Power Systems, Vol. 14, No.2, May 1999, pp.575-581.

[5] F.P. Demello and C. Concordia, "Concept of synchronous machine stability as affected by excitation control", IEEE Trans. PAS Vol. 88, 1969, pp 316-329.

[6] E.V. Larsen and D.A. Swann, "Applying Power System Stabilizers", Part I- III, IEEE Trans. PAS Vol. 100, no 6, 1981, pp 3017-3046.

[7] P. Kundur, "Power System Stability and Control", McGraw Hill Inc.1993.

[8] Cheng S, Malik O.P., Hope G.S., "Design of self-tuning PID stabilizer for a multi machine power system", IEE Proceedings, Part C, 1986; 133(4), pp 176-185.

[9] Hsu Y.Y., Liou K.L., Hsu Y.Y, Cheng C.V., "Design of fuzzy power system stabilizers for multi machine power systems ", IEE Proceedings, Part C,1990, 137(3).

[10] Y. Zhang, G.P. Chen, O.P. Malik and G.S. Hope, "An artificial neural based adaptive power system stabilizer ", IEEE Transactions on Energy Conversion, Vol.8, No.1, March 1993, pp.71-77.

[11] Y.Zhang, O.P.Malik and G.P.Chen, "Artificial neural network power system stabilizers in multi-machine power system environment ", IEEE Transactions on Energy Conversion, Vol. 10, No.1, March 1995, pp.147-154

[12] J. R. Jang, "ANFIS: Adaptive-network-Based Fuzzy Inference System", IEEE Trans. Syst. Man Cybernetics, vol. 23, no.3, pp. 665-685, May 1993

[13] T. Takagi, and M. Sugeno, "Derivation of fuzzy control rules from human operator's control actions", IFAC Symp. Fuzzy Inf. Knowledge Repres. Dec. Analysis, pp. 55-60, 1983.

[14] E. M. Abdelrahim, and T. Yahagi, "A new transformed input-domain ANFIS for highly nonlinear system modeling and prediction", Electrical and Computer Engineering, 2001. Canadian Conference on, vol. 1, pp. 655-660, 2001

[15] Jyh-Shing Roger Jang, Chuen-Tsai Sun, Eiji Mizutani, "Neuro-fuzzy and soft computing: a computational approach to learning and machine intelligence", Prentice-Hall, 1997

[16] Ravi Segala, Avdhesh Sharma, M.L. Kothari, "A self-tuning power system stabilizer based on artificial neural network", Electrical Power and Energy Systems 26 (2004) 423-430