

Tracking Performance Evaluation of Robust Back-Stepping Control Design for a Nonlinear Electrohydraulic Servo System

M. Ahmadnezhad, M. Soltanpour

Abstract—Electrohydraulic servo system have been used in industry in a wide number of applications. Its dynamics are highly nonlinear and also have large extent of model uncertainties and external disturbances. In this paper, a robust back-stepping control (RBSC) scheme is proposed to overcome the problem of disturbances and system uncertainties effectively and to improve the tracking performance of EHS systems. In order to implement the proposed control scheme, the system uncertainties in EHS systems are considered as total leakage coefficient and effective oil volume. In addition, in order to obtain the virtual controls for stabilizing system, the update rule for the system uncertainty term is induced by the Lyapunov control function (LCF). To verify the performance and robustness of the proposed control system, computer simulation of the proposed control system using Matlab/Simulink Software is executed. From the computer simulation, it was found that the RBSC system produces the desired tracking performance and has robustness to the disturbances and system uncertainties of EHS systems.

Keywords—Electro hydraulic servo system, back-stepping control, robust back-stepping control, Lyapunov redesign.

I. INTRODUCTION

ELECTROHYDRAULIC servo systems are widely used in many industrial applications because of their high power-to-weight ratio, high stiffness, and high payload capability, and at the same time, achieve fast responses and high degree of both accuracy and performance [1], [2]. However, the dynamic behavior of these systems is highly nonlinear due to phenomena such as nonlinear servo valve flow-pressure characteristics, variations in trapped fluid volumes, time varying behavior, nonlinear transmission effects, flow forces acting on spool, friction and associated stiffness which is not only largely uncertain but is greatly influenced by external load disturbances. These advantages, in turn, cause difficulties in the control of such systems.

Control techniques used to compensate the nonlinear behavior of hydraulic systems include adaptive control, sliding mode control, fuzzy control, feedback linearization and other less applicable methods such as genetic algorithm and optimum control.

M. Soltanpour is with the Department of Mechatronic Engineering, Science and Research Branch, Islamic Azad University, Sanandaj, Iran (corresponding author phone: +98 912 486 3071; e-mail: m_r_soltanpour@yahoo.com).

M. Ahmadnezhad is with the Department of Mechatronic Engineering, Science and Research Branch, Islamic Azad University, Sanandaj, Iran (e-mail: maria.ahmadnezhad@gmail.com).

Adaptive techniques to control EHS position have been proposed by researchers, which the most recent papers are [3]–[8], assuming linearized system models. These controllers have the ability to cope with small changes in system parameters such as valve flow coefficients, the fluid bulk modulus, and variable loading. However, there is no guarantee that the linear adaptive controllers will remain globally stable in the presence of large changes in the system parameters.

Variations of sliding mode controllers have also been developed for electrohydraulic servo systems. In according to the recently studies [9]–[14], these controllers are robust to large parameter variations, but the nearly discontinuous control signal excites unmodeled system dynamics and degrades system performance. This can be reduced by smoothing the control discontinuity in a small boundary layer bordering the sliding manifold as introduced in simulations [15], [16].

In order to cope with the nonlinear characteristics of EHS system such as saturation between voltage and current and dead zone due to the static friction, different fuzzy control techniques have been presented [17]–[25]. Fuzzy control have advantages such as Intuitive design, rules document the control action, no precise model needed, controller can be built up by experience and new rules can be added. On the other hand its advantages are: completeness of rules and their consistency, no stability is guaranteed, optimization by trial and error, care must be given for the control of critical systems, many tuning parameters (fuzzification, inference, defuzzification).

The nonlinear nature of the system behavior resulting from valve flow characteristics and actuator nonlinearities have been taken into account in application of the feedback linearization techniques [26], [27]. The main drawback of the resulting linearizable control law is that it relies on exact cancellation of the nonlinear terms. In addition, time scale difference of inner and outer loop must be large enough (inner loop must be much faster than desired overall closed loop dynamics) [28].

In addition to the above-mentioned methods, there are several less common methods for position controlling of EHS system. For instance, [29] presented the application of Genetic Algorithm Technique based on new fitness function to optimally tune the three terms of the classical PID controller to regulate a valve controlled hydraulic servo-system as a nonlinear process. The optimized PID improves the performances of the hydraulic servo-system in

order to achieve minimum settling time with no overshoot and nearly zero steady state error. A disadvantage of the proposed method is the necessity of the definition of parameters for a performance index by the user, which impedes the procedure to be fully automatic. P. Olanthichachat et al. proposed a new technique to design an optimal robust PI-controller for electro-hydraulic servo system to achieve both the robustness and performance [30].

In this paper, a robust back-stepping control (RBSC) scheme is proposed for EHS systems to obtain the desired tracking performance and the robustness to system uncertainties. First, to realize a stable back-stepping control (BSC) system with a closed-loop structure and to select new state variables, EHS system dynamics are represented with state equations and error equations. Defining the Lyapunov Control Functions (LCF), a BSC system can be designed, which can guarantee exponential stability for the nominal system without system uncertainties. However, the BSC system cannot achieve robustness to system uncertainties. To overcome the drawback of the BSC system, an RBSC scheme for EHS position control systems was proposed. To evaluate the tracking performance and robustness of the proposed EHS position control system, both BSC and RBSC schemes were evaluated by computer simulation. Procedure for Paper Submission

II. EHS DYNAMIC MODEL

Typical electro-hydraulic servo system is shown in Fig. 1 which consists of a position control system. The voltage applied to the solenoid coil results in the current flowing through the coil. The current is function of resistance and inductance of coil. Inductance in turn depends on spool position of the valve (spool and plunger are connected). The spool movement generates the orifice which causes the flow of fluid in the chambers of cylinders. Pressure in the chamber grows and pressure difference is created in cylinder. The pressure differential of fluid at piston of cylinder drives the load.

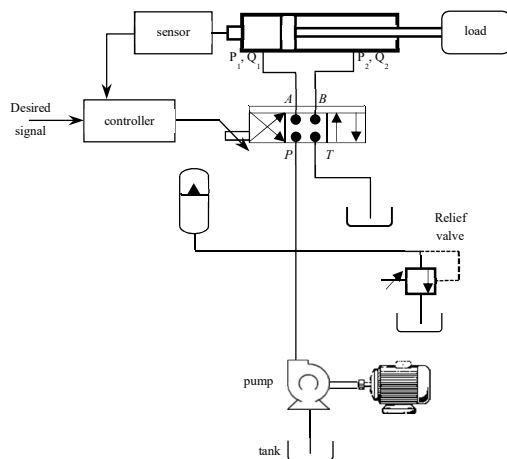

Fig. 1 Typical electro-hydraulic servo system

Mathematical model of electro-hydraulic actuator consists of the dynamics of the system disturbed by an external load and the dynamics of a servo valve. The relation between actuator-valve dynamics and load flow rate based on the Orifice law are given by:

$$Q_L = K_Q x_v - K_C P_L \quad (1)$$

where Q_L is load flow, $P_L = P_1 - P_2$ is load pressure, X_v is servo valve spool displacement, K_C is pressure gain under different performance points and K_Q is valve flow gain that changes in different performance points. So:

$$K_Q = K_v c_d \omega \sqrt{\frac{P_s - sgn(x_v) P_L}{\rho}} \quad (2)$$

where K_v is servo valve gain, c_d is cylinder discharge coefficient, ω is servo valve area gradient, ρ is oil density and P_s is tank pressure. When servo valve is considered as a zero level system then:

$$X_v = K_{ui} u \quad (3)$$

where K_{ui} is amplifier gain of the servo and u is input signal of servo valve controlling. Considering leakage and compressibility, the stream continuity equation for cylinder chamber is obtained:

$$Q_L = A \dot{X} + \frac{V_t}{4B} \dot{P}_L + K_{ce} P_L \quad (4)$$

where A is pressurized area in actuator, V_t is effective oil volume in system, B is effective viscosity coefficient of oil, K_{ce} is total leakage coefficient of cylinder and \dot{X} is cylinder shaft speed. The equilibrium equation for cylinder is obtained as:

$$A P_L = M \ddot{x} + n \dot{x} + K_s x + F_f \quad (5)$$

where M is effective mass of system, n is viscous friction factor, K_s is the elastic load hardness and F_f is the external disturbance. Combining (4) and (5) the set of system state equations are obtained as:

$$\dot{X}_1 = X_2 \quad (6)$$

$$\dot{X}_2 = X_3 \quad (7)$$

$$\dot{X}_3 = f(X(t), t) + g(X_1)u(t) - d(t) \quad (8)$$

$$f(X(t), t) = -a_1(X_1)X_2 - a_2(X_1)X_3 \quad (9)$$

$$a_1(X_1) = \frac{4B(AR(1+0.3 \sin(X_1)))^2 + 4BK_{ce}(X_1)n + k_\delta V_t}{IV_t} \quad (10)$$

$$a_2(X_1) = \frac{n}{I} + \frac{4BK_{ce}(X_1)}{V_t} \quad (11)$$

$$g(X_1) = \frac{4BAR(1+0.3 \sin(X_1))}{IV_t} K_Q K_v K_{ui} \quad (12)$$

$$d(t) = \frac{4BK_{ce}(X_1)}{IV_t} M(t) + \frac{1}{I} \frac{dM(t)}{dt} \quad (13)$$

where R is the effective length of connection arm, I is the inertia torque and K_δ is the position torque factor. $d(t)$ is demonstrated as system disturbances. Also:

$$K_{ce}(X_1) = C_e(X_1) + K_c = C_{ess} \left(1 - e^{-X_1/\delta_{ce}}\right) + K_c \quad (14)$$

III. CONTROLLER DESIGN

In this chapter, the BSC and RBSC schemes based on EHS system dynamics are considered as the position controller. Fig. 2 shows the control structure for a multivariable control system. The goal is to control the position x_d in order to follow a desired trajectory of position. In this section a robust multivariable control system is presented which reduces the sensitivity to changing parameters related to system disturbances and variety of uncertainties. The back-stepping approach [30] which is commonly known and relatively easy to implement will be used for the EHS system. The main contribution of this paper is the application of back-stepping techniques to an EHS system. A recursive framework is proposed to construct a Lyapunov function and corresponding control actions for the system stabilization [9]. This idea is adopted to design a nonlinear controller for position tracking in the EHS system.

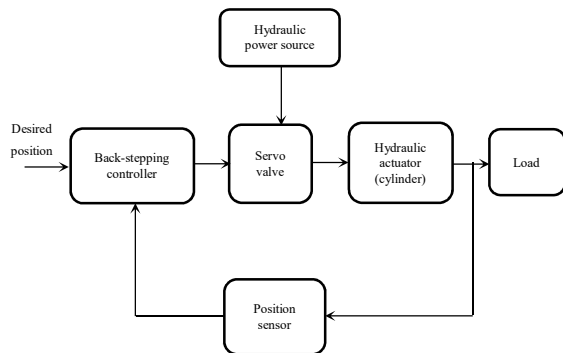

Fig. 2 Control structure for a multivariable control system

A. Standard Back-Stepping

In this chapter, we present our recursive back-stepping design procedure via Lyapunov functions for the EHS system. Firstly, to design a BSC system, (6), (7) and (8) that represent state equations is rewritten as:

$$\begin{cases} \dot{x}_1 = x_2 \\ \dot{x}_2 = x_3 \\ \dot{x}_3 = f + gu - d \end{cases} \quad (15)$$

And, in order to design the BSC system, new state variables are defined as:

$$z_1 = x_1 - x_d \quad (16)$$

$$z_2 = x_2 - \alpha_1(z_1) \quad (17)$$

$$z_3 = x_3 - \alpha_2(z_1, z_2) \quad (18)$$

where x_d is the desired position input, and α_1 and α_2 are the functions for new state variables, which can be obtained through the following BSC design procedure.

Step 1.

From (16), the state equation for z_1 can be described as

$$\dot{z}_1 = z_2 + \alpha_1(z_1) - \dot{x}_d \quad (19)$$

$\alpha_1(z_1)$ is the virtual control which should be selected to guarantee the stability of the control system through the Lyapunov control function(LCF) which is defined as

$$V_1(z_1) = \frac{1}{2} z_1^2 \quad (20)$$

Then

$$\dot{V}_1(z_1) = z_1 \dot{z}_1 = z_1[\alpha_1(z_1) - \dot{x}_d] + z_1 z_2 \quad (21)$$

From (21), if $\alpha_1(z_1) = -k_1 z_1 + \dot{x}_d$, (19) can be exponentially stable when $t \rightarrow \infty$ and $k_1 (> 0)$ is a design parameter.

Step 2

From (17), the state equation for z_2 can be described as

$$\dot{z}_2 = z_3 + \alpha_2(z_1, z_2) - \dot{\alpha}_1(z_1) \quad (22)$$

where

$$\dot{\alpha}_1(z_1) = \frac{\partial \alpha_1}{\partial z_1} \dot{z}_1 + \frac{\partial \alpha_1}{\partial \dot{x}_d} \ddot{x}_d = -k_1 \dot{z}_1 + \ddot{x}_d = -k_1(z_2 - k_1 z_1) + \ddot{x}_d \quad (23)$$

Since (22) includes the information of (19), the second LCF for obtaining the virtual control to guarantee the stability of the control system can be selected as

$$V_2(z_1, z_2) = V_1(z_1) + \frac{1}{2} z_2^2 \quad (24)$$

Then

$$\dot{V}_2(z_1, z_2) = \dot{V}_1(z_1) + z_2 \dot{z}_2 = -k_1 z_1^2 + z_2 z_3 + z_2 [z_1 + \alpha_2(z_1, z_2) - \dot{\alpha}_1(z_1)] \quad (25)$$

If the virtual control α_2 in the last term of (25) is defined as

$$\alpha_2(z_1, z_2) = -k_2 z_2 - z_1 + \dot{\alpha}_1(z_1) \quad (26)$$

where $k_2 (> 0)$ is a design parameter, then another expression of α_2 can be rearranged as

$$\alpha_2(z_1, z_2) = -(k_1 + k_2)z_2 - (1 - k_1^2)z_1 + \ddot{x}_d \quad (27)$$

Therefore

$$\dot{V}_2 = z_2 z_3 - k_1 z_1^2 - k_2 z_2^2 \quad (28)$$

Step 3.

From (18), the state equation for z_3 is described as

$$\dot{z}_3 = \dot{x}_3 - \dot{\alpha}_2(z_1, z_2) = f + gu - d - \dot{\alpha}_2(z_1, z_2) \quad (29)$$

where

$$\dot{\alpha}_2(z_1, z_2) = \frac{\partial \alpha_2}{\partial z_1} \dot{z}_1 + \frac{\partial \alpha_2}{\partial z_2} \dot{z}_2 + \frac{\partial \alpha_1}{\partial \hat{\alpha}_1} \dot{\hat{\alpha}}_1 = -\dot{z}_1 - k_2 \dot{z}_2 + \dot{\hat{\alpha}}_1 \quad (30)$$

and

$$\ddot{\alpha}_1 = \frac{\partial \dot{\alpha}_1}{\partial z_1} \dot{z}_1 + \frac{\partial \dot{\alpha}_1}{\partial z_2} \dot{z}_2 + \frac{\partial \dot{\alpha}_1}{\partial \ddot{x}_d} \ddot{x}_d = k_1^2 \dot{z}_1 - k_1 \dot{z}_2 + \ddot{x}_d \quad (31)$$

Substituting (19), (22), and (31) into (30), (30) can be rearranged as

$$\dot{\alpha}_2(z_1, z_2) = (k_1^2 - 1)\dot{z}_1 - (k_1 + k_2)\dot{z}_2 + \ddot{x}_d \quad (32)$$

Since (29) uses the information of z_1 and z_2 due to the property of the design procedure of the back-stepping control, the third LCF for (18) can be defined as

$$V_3(z_1, z_2, z_3) = V_2(z_1, z_2) + \frac{1}{2}z_3^2 \quad (33)$$

Then

$$\dot{V}_3(z_1, z_2, z_3) = \dot{V}_2 + z_3 \dot{z}_3 = -k_1 z_1^2 - k_2 z_2^2 + z_3(f + gu - d - \dot{\alpha}_2) \quad (34)$$

If the last term of (34) for satisfying the system stability is defined as

$$-k_3 z_3 = f + gu - d - \dot{\alpha}_2 \quad (35)$$

Then the BSC law can be selected as

$$u = \frac{1}{b}(\dot{\alpha}_2 - k_3 z_3 - f + d) \quad (36)$$

Now the negative semi-definite of \dot{V}_3 can be obtained by substituting (36) into (34) as

$$\dot{V}_3(z_1, z_2, z_3) = \dot{V}_2 + z_3 \dot{z}_3 = -k_1 z_1^2 - k_2 z_2^2 - k_3 z_3^2 \leq 0 \quad (37)$$

From (37), it is found that EHS position control systems using the BSC law of (36) can guarantee exponential stability.

B. Robust Back-Stepping

If system uncertainties can be exactly known, the BSC law of (36) can achieve the desired tracking performance and the robustness to the system uncertainties of EHS systems. However, the BSC law of (36) will cause a tracking error and does not achieve the robustness to the system uncertainties because the value of f cannot be exactly known. To improve the tracking performance and the robustness to the system uncertainties, the value of f , in which system uncertainties are included, should be estimated. Therefore, in this chapter, an ABSC scheme is proposed, which is the BSC scheme with the estimator of f . In order to design the ABSC system, the BSC law of (36) is modified as

$$u = \frac{1}{b}(\dot{\alpha}_2 - k_3 z_3 - \hat{f} - \rho \text{sign}(z_3)) \quad (38)$$

where \hat{f} is the estimator of the system uncertainties and ρ is a positive constant.

Substituting (38) into (15), (15) is modified as

$$\begin{cases} \dot{x}_1 = x_2 \\ \dot{x}_2 = x_3 \\ \dot{x}_3 = \hat{f} + \dot{\alpha}_2 - k_3 z_3 + \rho \text{sign}(z_3) \end{cases} \quad (39)$$

where $\tilde{f} = f - \hat{f}$

From (38), the LCF is defined as

$$V_4 = \frac{1}{2}z_1^2 + \frac{1}{2}z_2^2 + \frac{1}{2}z_3^2 \quad (40)$$

The derivative of (39) can be described as

$$\dot{V}_4 = z_1 \dot{z}_1 + z_2 \dot{z}_2 + z_3 \dot{z}_3 \quad (41)$$

Substituting \dot{z}_3 into (41), (41) is rearranged as

$$\dot{V}_4 = -k_1 z_1^2 - k_2 z_2^2 + z_3(f + gu - d - \dot{\alpha}_2) \quad (42)$$

Replacing gu from (38), (42) is modified as

$$\dot{V}_4 = -k_1 z_1^2 - k_2 z_2^2 + z_3(f + \dot{\alpha}_2 - k_3 z_3 - \hat{f} - \rho \text{sign}(z_3)) - d - \dot{\alpha}_2 \quad (43)$$

Then

$$\dot{V}_4 = -k_1 z_1^2 - k_2 z_2^2 - k_3 z_3^2 + z_3(\tilde{f} - \rho \text{sign}(z_3) - d) \quad (44)$$

Considering $\rho \text{sign}(z_3) = \rho \frac{z_3}{|z_3|}$, (44) is rearranged as

$$\dot{V}_4 = -k_1 z_1^2 - k_2 z_2^2 - k_3 z_3^2 + z_3(\tilde{f} - d) - \rho \frac{z_3^2}{|z_3|} \quad (45)$$

As regards to $\rho \frac{z_3^2}{|z_3|} = \rho |z_3|$, (42) can be rewritten as

$$\dot{V}_4 = -k_1 z_1^2 - k_2 z_2^2 - k_3 z_3^2 + z_3(\tilde{f} - d) - \rho |z_3| \quad (46)$$

The negative semi-definite of \dot{V}_4 can be obtained if

$$z_3(\tilde{f} - d) - \rho |z_3| \leq 0 \quad (47)$$

$$|\tilde{f} - d| \leq \rho \quad (48)$$

From (16), (17), and (18), these equations are the error equations for the velocity, acceleration and jerk of the piston, which include $\alpha_1(z_1)$ and $\alpha_2(z_1, z_2)$ that guarantee the exponential stability of EHS position control systems. Substituting these equations into (39), the error dynamics can be represented as

$$\begin{cases} \dot{z}_1 = z_2 - k_1 z_1 \\ \dot{z}_2 = z_3 - k_1 z_1 - z_1 \\ \dot{z}_3 = \tilde{f} - k_3 z_3 + \rho \text{sign}(z_3) \end{cases} \quad (49)$$

IV. RESULTS AND DISCUSSION

In order to evaluate the validity of the proposed control scheme for EHS position control systems, a sinusoidal reference input was considered as

$$x_d = \sin(2\pi t) \quad (50)$$

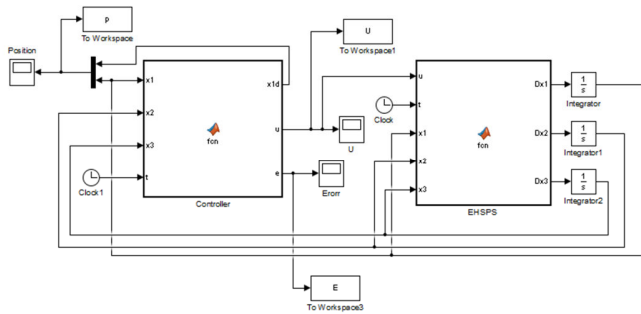

Fig. 3 Block diagram of the EHS position control system

This sinusoidal reference input is suitable for evaluating the tracking performance and the robustness of EHS position control systems because it reflects the various changes in the magnitudes of the position of the piston. Table I shows the system parameters of the EHS system which are used to computer simulation. Fig. 3 shows the block diagram of the EHS position control system.

TABLE I
 SYSTEM PARAMETERS OF THE ELECTROHYDRAULIC SERVO

Symbol	Quantity	amount
K_{hi}	amplifier gain of servo valve	0.005
K_v	gain of servo valve	8.67
K_Q	gain of servo valve flow	0.012
A	actuator area	0.001
R	effective length of connection arm	0.17
V_t	oil volume	$2e^{-4}$
C_{ess}	Total leakage coefficient	$2.4e^{-11}$
K_c	gain of servo valve pressure	$4.8e^{-12}$
B	oil viscosity	$1.17e^8$
n	viscous friction coefficient	30.65
I	inertia torque	1.16
δ_K	position torque coefficient	$5.8e^4$

The simulation is performed in usual, with disturbances states and with disturbances plus 10% uncertainties. In this paper, total leakage coefficient of cylinder and effective oil volume in system are considered as EHS system uncertainties.

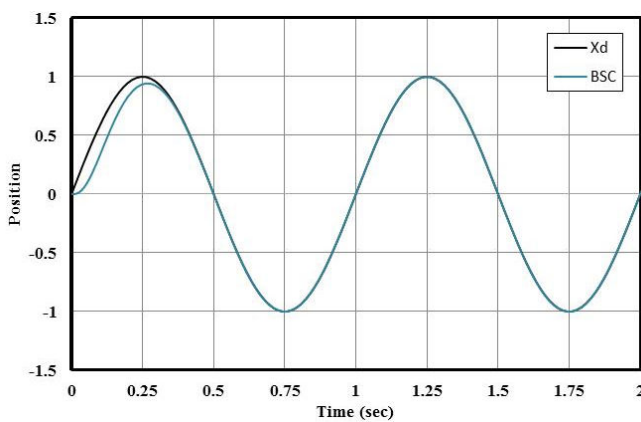

Fig. 4 Simulation of piston position tracking for standard back-stepping controller in the absence of disturbances and uncertainties

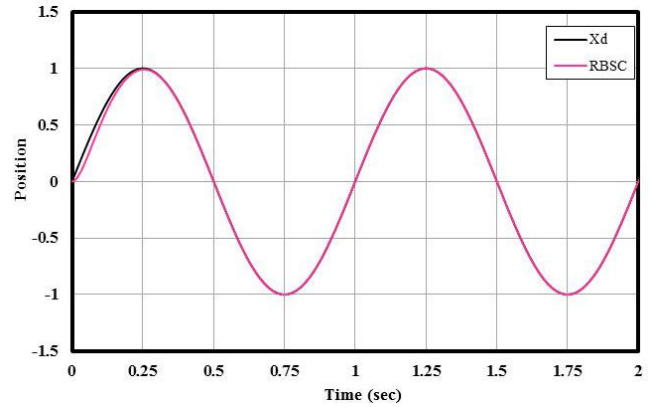

Fig. 5 Simulation of piston position tracking for robust back-stepping controller in the absence of disturbances and uncertainties

The controlling of piston position of EHS system using back-stepping and robust back-stepping is compared in Fig. 4. As shown in Fig. 4, in the absence of disturbances and any uncertainties, both controllers have shown good performance. But robust controller has better performance as illustrated in Fig. 5.

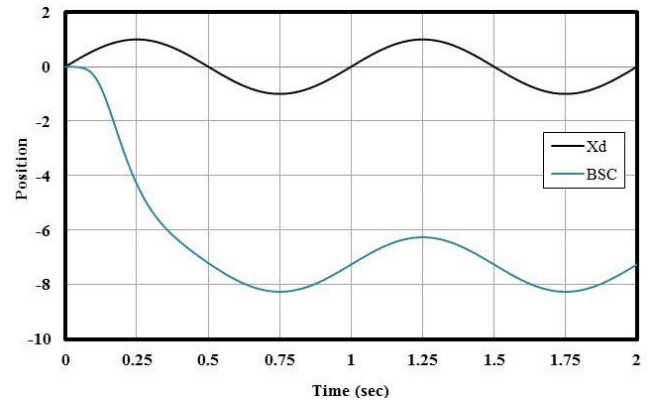

Fig. 6 Simulation of piston position tracking for standard back-stepping controller with disturbances

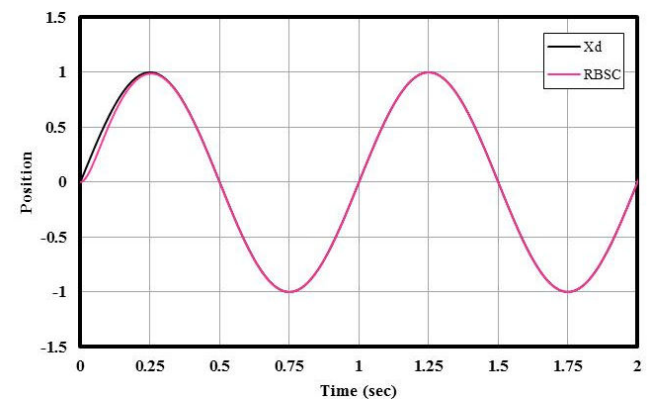

Fig. 7 Simulation of piston position tracking for robust back-stepping controller with disturbances

By applying disturbances in system, it is found that the distance of piston position will be further from desired

position in the standard back-stepping controller. In this situation, the controller tracked the desired position in the unknown range, as demonstrated in Fig. 6. In the other hand, robustness of proposed controller with disturbances is illustrated in Fig. 7. It can be seen that, robustness is done very well.

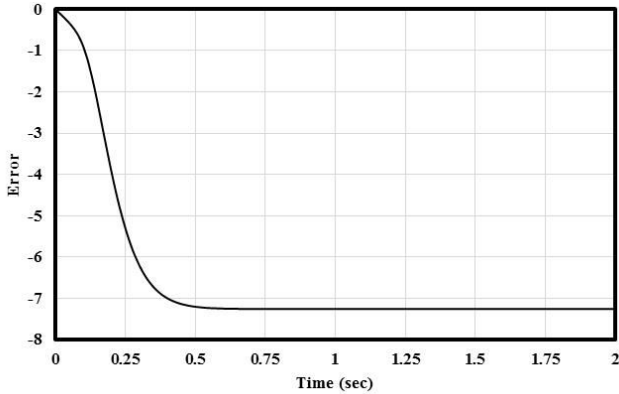

Fig. 8 Simulation of error for standard back-stepping controller with disturbances

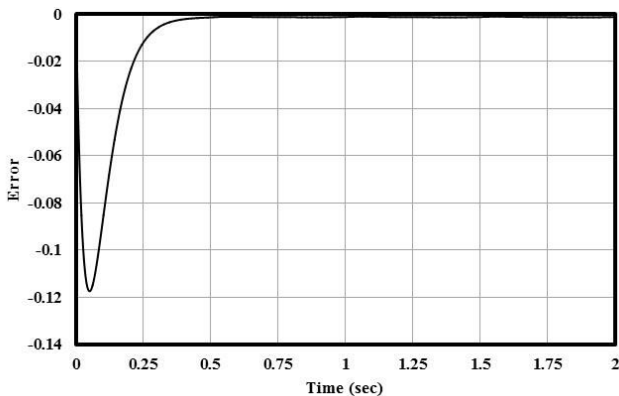

Fig. 9 Simulation of error for robust back-stepping controller with disturbances

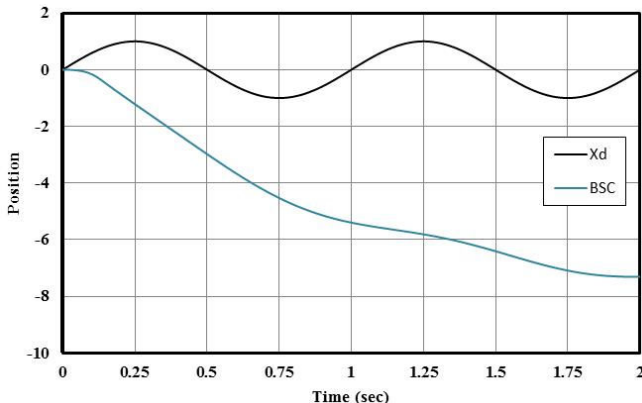

Fig. 10 Simulation of piston position tracking for standard back-stepping controller with disturbances and considering 10% uncertainties in total leakage coefficient of cylinder and effective oil volume in system

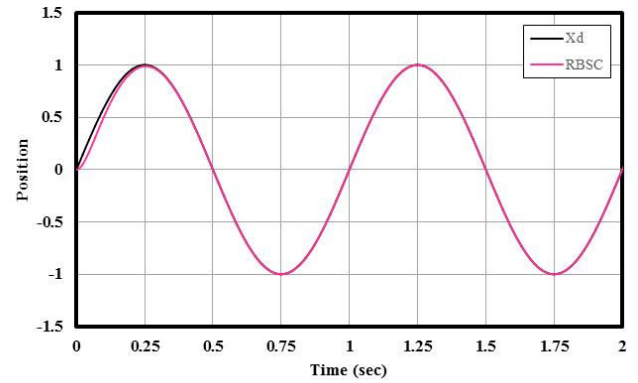

Fig. 11 Simulation of piston position tracking for robust back-stepping controller with disturbances and considering 10% uncertainties in total leakage coefficient of cylinder and effective oil volume in system

The error of back-stepping and robust back-stepping controller in the presence of disturbances is also shown in Figs. 8 and 9 respectively. From the figures, position control error of robust controller reached the zero in comparison to the increasing of standard back-stepping error.

In addition to the presence of disturbances, 10% uncertainties of EHS system is considered, In order to examine the proposed robust controller further.

In this step, the simulation results of EHS system position controlling are shown in Figs. 10 and 11, using back-stepping and robust back-stepping controller respectively. In Fig. 10 the position control performance deteriorated. And the curve trend is decreasing.

On the other hand a good performance is attained using robust back-stepping controller. Also the position controlling error of standard and robust back-stepping controller is shown in Figs. 12 and 13 respectively. Similar to the previous state, the error of standard back-stepping controller is growing increasingly while the error trend achieved in a short time using robust back-stepping controller.

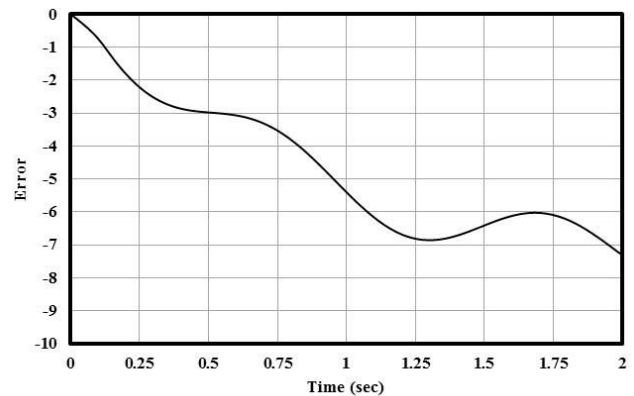

Fig. 12 Simulation of error for standard back-stepping controller with disturbances and considering 10% uncertainties in total leakage coefficient of cylinder and effective oil volume in system.

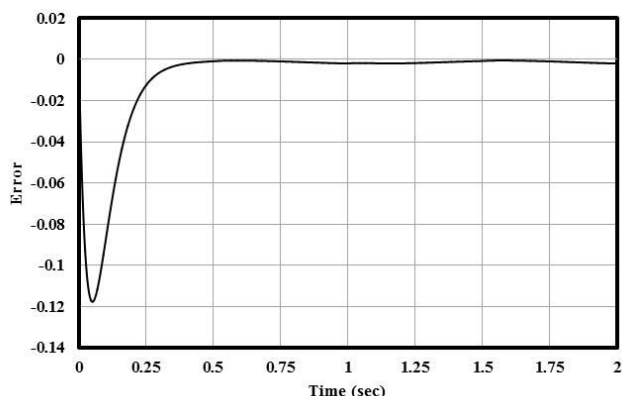

Fig. 13 Simulation of error for robust back-stepping controller with disturbances and considering 10% uncertainties in total leakage coefficient of cylinder and effective oil volume in system.

V.CONCLUSION

A robust position control of EHS systems was proposed by using the RBSC scheme, which has robustness to disturbances of viscous friction and also by considering uncertainties like total leakage coefficient and effective oil volume. Firstly, a stable BSC system based on the EHS system dynamics was derived. However, the BSC scheme had a drawback: it could not consider disturbances and system uncertainties. To overcome the drawback of the BSC scheme, the RBSC scheme was proposed. To evaluate the performance and robustness of the proposed EHS position control system, BSC and RBSC schemes were implemented in a computer simulation. It was found that the RBSC scheme can yield the desired tracking performance and the robustness to disturbances and system uncertainties.

REFERENCES

- [1] H. E. Merrit, *Hydraulic Control Systems*. New York: John Wiley & Sons Inc, 1967.
- [2] J. Watton, *Fluid Power Systems*. New Jersey: Prentice Hall, 1989.
- [3] J. E. Bobrow and K. Lum, "Adaptive, High Bandwidth Control of a Hydraulic Actuator," *Trans. of the ASME, Journal of Dynamic Systems, Measurement and Control*, Vol. 118, No. 4, pp. 714-720, 1996.
- [4] Yao, Jianjun, et al. "Adaline neural network-based adaptive inverse control for an electro-hydraulic servo system," *Journal of Vibration and Control* (2011).
- [5] H. M. Kim, et al. "Robust Position Control of Electro-Hydraulic Actuator Systems Using the Adaptive Back-Stepping Control Scheme Proceedings of the Institution of Mechanical Engineers," *Part I: Journal of Systems and Control Engineering*, 224: 737-746, September 2010.
- [6] W. Piotr, and R. Dindorf, "Adaptive Control of the Electro-Hydraulic Servo-System with External Disturbances." *Asian Journal of Control* 15.4, 1065-1080, 2013.
- [7] Y. Jianyong, J. Zongxia, "Electrohydraulic positioning servo control based on its adaptive inverse model," *6th IEEE Conference on Industrial Electronics and Applications*, 1698, 1701, 21-23, June 2011.
- [8] K. Claude, J-P. Kenne, and M. Saad. "Indirect adaptive control of an electrohydraulic servo system based on nonlinear backstepping," *IEEE/ASME Transactions on Mechatronics*, 16.6, 1171-1177, 2011.
- [9] S. Lasse, A. T. Ole, P. H. Clemmensen, "Robust Non-Chattering Observer Based Sliding Control Concept for Electro-Hydraulic Drives," *6th IFAC Symposium on Mechatronic Systems*, 99-108, Zhejiang University, Hangzhou, China, 2013.
- [10] C. Dong, J. Lu, Q. Meng, "Position control of an electro-hydraulic servo system based on improved Smith predictor," *International Conference on Electronic and Mechanical Engineering and Information Technology*, vol.6, pp.2818,2821, Aug. 2011.

- [11] S. Kurode, P. G. Desai, A. Shiralkar, "Modeling of electro-hydraulic servo valve and Robust Position Control using Sliding Mode Technique," *Proceedings of the 1st International and 16th National Conference on Machines and Mechanisms*, IIT Roorkee, India, Dec 2013.
- [12] W. M. Bessa, M. S. Dutra, E. Kreuzer, "Sliding Mode Control with Adaptive Fuzzy Dead-Zone Compensation of an Electro-hydraulic Servo-System," *Journal of Intelligent and Robotic Systems*, Volume 58, Issue 1, pp 3-16, 2010.
- [13] M. F. Rahmat, et al. "Modeling and controller design of an industrial hydraulic actuator system in the presence of friction and internal leakage." *International Journal of Physical Sciences*, 6.14, 3502-3517, 2011.
- [14] W. Hongyan, Q. Jihong, W. Qinglin, "A hybrid adaptive wavelet neural network control and sliding mode control for electro-hydraulic servo system," *29th Chinese Control Conference*, pp.2328, 2333, July 2010.
- [15] T. L. Chern and Y. C. Wu, "Design of Integral Variable Structure Controller and Application to Electrohydraulic Velocity Servosystems," *IEE Proceedings D (Control Theory and Applications)*. Vol. 138. No. 5. IET Digital Library pp. 439-444, 1991.
- [16] R. F. Fung and R. T. Yang, "Application of Variable Structure Controller in Position Control of a Nonlinear Electrohydraulic Servo System," *Computers & Structures*, Vol. 66, No. 4, pp. 365-372, 1998.
- [17] P. Pornjit, S. Thongchai, and S. Tansriwong. "A hybrid of fuzzy and proportional-integral-derivative controller for electro-hydraulic position servo system." *Energy Research Journal*, 1.2, 62-67, 2010.
- [18] S. Kwanchai, et al. "A hybrid of fuzzy and fuzzy self-tuning PID controller for servo electro-hydraulic system." *6th IEEE Conference on Industrial Electronics and Applications*, 2011.
- [19] A. Ramli, et al. "Self-tuning fuzzy PID controller for electro-hydraulic cylinder." *7th International Colloquium on Signal Processing and its Applications*, 2011.
- [20] Y. Lin-ke, et al. "Fuzzy PID control for direct drive electro-hydraulic position servo system," *International Conference on Consumer Electronics, Communications and Networks (CECNet)*, pp. 370-373, April 2011.
- [21] R. Mohd, et al. "Self-tuning position tracking control of an electro-hydraulic servo system in the presence of internal leakage and friction." *International Review of Automatic Control*, 3.6, 684-691, 2010.
- [22] O. Cerman, and P. Hušek, "Adaptive fuzzy sliding mode control for electro-hydraulic servo mechanism," *Expert Systems with Applications*, Volume 39, Issue 11, Pages 10269-10277, 2012.
- [23] Y. Bai, P. Li, "Adaptive fuzzy sliding mode control for Electro-hydraulic position servo system," *Control and Decision Conference*, Chinese, pp. 3249-3253, May 2010.
- [24] A. A. Aly, et al. "Intelligent PI Fuzzy Control of An Electro-Hydraulic Manipulator." *International Journal of Intelligent Systems and Applications (IJISA)*, 4.7, 43, 2010.
- [25] H. M. Kim, et al. "A robust control of electro hydrostatic actuator using the adaptive back-stepping scheme and fuzzy neural networks," *International Journal of Precision Engineering and Manufacturing*, Volume 11, Issue 2, pp. 227-236, 2010.
- [26] G. Vossoughi and M. Donath, "Dynamic Feedback Linearization for Electrohydraulic Actuated Control Systems," *Trans. of the ASME, Journal of Dynamic Systems, Measurement and Control*, Vol. 117, No. 3, pp. 468-477, 1995.
- [27] M. H. Angue, et al. "Feedback linearization-based position control of an electrohydraulic servo system with supply pressure uncertainty," *IEEE Transactions on Control Systems Technology*, 20.4, 1092-1099, 2012.
- [28] P. Gruber and S. Balemi, "Overview of non-linear control methods," Swiss, May 2010.
- [29] A. A. Aly, "PID Parameters Optimization Using Genetic Algorithm Technique for Electrohydraulic Servo Control System," *Intelligent Control and Automation*, 2, 69-76, 2011.
- [30] P. Olanthichachai, S. Kaitwanidvilai, "Design of Optimal Robust PI Controller for Electro-Hydraulic Servo System," *Engineering Letters*, vol. 19, no. 3, 2011.