

Supplementation of Annatto (*Bixa orellana*)-Derived δ -Tocotrienol Produced High Number of Morula through Increased Expression of 3-Phosphoinositide-Dependent Protein Kinase-1 (PDK1) in Mice

S. M. M. Syairah, M. H. Rajikin, A-R. Sharaniza

Abstract—Several embryonic cellular mechanism including cell cycle, growth and apoptosis are regulated by phosphatidylinositol-3-kinase (PI3K)/Akt signaling pathway. The goal of present study is to determine the effects of annatto (*Bixa orellana*)-derived δ -tocotrienol (δ -TCT) on the regulations of PI3K/Akt genes in murine morula. Twenty four 6-8 week old (23-25g) female balb/c mice were randomly divided into four groups (G1-G4; n=6). Those groups were subjected to the following treatments for 7 consecutive days: G1 (control) received tocopherol stripped corn oil, G2 was given 60 mg/kg/day of δ -TCT mixture (contains 90% delta & 10% gamma isomers), G3 was given 60 mg/kg/day of pure δ -TCT (>98% purity) and G4 received 60 mg/kg/day α -TOC. On Day 8, females were superovulated with 5 IU Pregnant Mare's Serum Gonadotropin (PMSG) for 48 hours followed with 5 IU human Chorionic Gonadotropin (hCG) before mated with males at the ratio of 1:1. Females were sacrificed by cervical dislocation for embryo collection 48 hours post-coitum. About fifty morulas from each group were used in the gene expression analyses using Affymetrix QuantiGene Plex 2.0 Assay. Present data showed a significant increase ($p < 0.05$) in the average number (mean \pm SEM) of morula produced in G2 (27.32 ± 0.23), G3 (25.42 ± 0.21) and G4 (27.21 ± 0.34) compared to control group (G1 - 14.61 ± 0.25). This is parallel with the high expression of *PDK1* gene with increase of 2.75-fold (G2), 3.07-fold (G3) and 3.59-fold (G4) compared to G1. From the present data, it can be concluded that supplementation with δ -TCT(s) and α -TOC induced high expression of *PDK1* in G2-G4 which enhanced the PI3K/Akt signaling activity, resulting in the increased number of morula.

Keywords—Embryonic development, morula, nicotine, vitamin E.

I. INTRODUCTION

FOLLOWING fertilization, preimplantation embryos continue to grow from 1-cell stage towards hatched blastocyst stage through a number of cellular mitosis. Morula (Fig. 1) is formed at Day 3-4 post-fertilization and it is recognized by its appearance of a number of cells attached together in a ball-like shape [1]. It is at this stage where the

process of compaction begins with the outer part of morula become tightly bounded with the formation of gap junctions and desmosomes [2]. Morula also is considered as an important stage of development because cells started to differentiate into functional body cells (reviewed in [3]).



Fig. 1 Murine morula at Day 3 post-fertilization (X40)

Embryonic development is controlled by a number of cellular signaling transductions; amongst them are the phosphatidylinositol-3-kinase (PI3K)/Akt pathway [4]. PI3K/Akt pathway is widely known to possess the central role in several cellular mechanism including cell proliferation and growth, development and apoptosis [5], [6]. One of the major role players in PI3K/Akt pathway is the 3-phosphoinositide-dependent protein kinase-1 (PDK1). PDK1 activation is essential as it is required for activation of the Akt protein. Activated Akt will modulate a number of regulatory substances which involve in cell proliferation and apoptosis [7].

Tocopherols (TOCs) and tocotrienols (TCTs) are the two major substances of Vitamin E present in the different form of isomers namely α -, β -, γ - and δ -tocopherol and α -, β -, γ - and δ -tocotrienol. They are essential nutrition in diet which helps in prevention of cancer, neurodegenerative and cardiovascular diseases [8]-[10]. In embryogenesis study, tocotrienol-rich fractions (TRFs) have been reported to reverse the adverse effects of oxidative stress induced by corticosterone [11], [12] and nicotine [13] on pregnancy and embryo development in mice. Reference [14] also reported that γ -TCT is able to improve development in porcine embryos subjected to hydrogen peroxide (H_2O_2) treatment. To our knowledge, the effect of δ -TCT on normal preimplantation embryonic growth has not been reported. Therefore, this study was conducted to determine the effects of δ -TCT following maternal

Syairah, S.M.M. is with the Faculty of Medicine, Universiti Teknologi MARA (UiTM) Sg. Buloh Campus, Selangor, Malaysia, on leave from Faculty of Pharmacy, UiTM, Puncak Alam Campus, Selangor, Malaysia (e-mail: syairah@puncakalam.uitm.edu.my).

Rajikin M.H. and Sharaniza A-R. are with the Faculty of Medicine, Universiti Teknologi MARA (UiTM) Sg. Buloh Campus, Selangor, Malaysia.

This study was financially supported by the Ministry of Education (MOE), Malaysia through Fundamental Research Grant Scheme (FRGS Grant) (600-RMI/FRGS 5/3/ (60/2012)

supplementation on morula production and the subsequent regulation of PI3K/Akt pathway using δ -TCT derived from the annatto plant (*Bixa orellana*) in mice.

II. MATERIAL AND METHODS

A. Ethics Approval

All procedures were carried out in accordance with the guidelines approved by Laboratory Animal Care Unit (LACU) as per the recommendations of the university's Committee on Animal Research and Ethics (CARE) and Animal Care and Use Committee (ACUC-7/13).

B. Animal Treatment

Twenty four of 6-8 weeks old (23-25g) male and female balb/c mice (purchased from Chenur Supplier, Kajang, Malaysia) were acclimatized in controlled temperature and humidity (24°C, 12-h light/dark cycle) with vitamin E-free pellets and water given *ad libitum* for one week. Following this, all females were randomly grouped into four groups (G1-G4) of six mice each. The groups were treated according to the following treatments (Table I) for 7 consecutive days:

TABLE I
TREATMENTS GIVEN TO THE EXPERIMENTAL GROUPS

Groups	Treatment	Route of Intake
G1 (control)	Corn oil tocopherol stripped (Acros Brand, Premier Diagnostics Sdn. Bhd., Malaysia)	Oral-gavage
G2	δ -TCT mixture (90% delta:10% gamma) (60 mg/kg/day)	Oral-gavage (δ -TCT mixture, pure δ - TCT and α -tocopherol were dissolved in tocopherol-stripped corn oil prior to force-feeding)
G3	Pure δ -TCT (delta >98% purity) (60 mg/kg/day)	
G4	α -tocopherol (60 mg/kg/day)	

C. Mating

Prior to mating, all females were superovulated with subcutaneous (s.c.) injection of 5 IU Pregnant Mare's Serum Gonadotropin (PMSG), followed with 5 IU of human Chorionic Gonadotropin (hCG) (s.c.) 48 hours later. All mice were individually housed in a cage for mating (48 hours) in the ratio of 1 male to 1 female. Mating was confirmed by the presence of vaginal plug. Animals were then sacrificed by cervical dislocation.

D. Embryo Collection and Culture

Sacrificed females were immediately dissected to retrieve the Fallopian tubes for embryo collection. Fallopian tubes were flushed with M2 medium (Sigma Aldrich, USA) under a dissecting microscope (Leica Zoom 2000, Japan). Collected embryos were washed in M2 medium before cultured *in vitro* in 100 μ l M16 medium (Sigma Aldrich, USA) and overlaid with mineral oil (Sigma Aldrich, USA). Culture mediums were prepared overnight for homogenization prior to use. Embryos were incubated at 37°C (5% CO₂). Embryonic development until morula stage was observed daily under the inverted microscope (Olympus 1X81 SF-3, Japan). An

average of fifty morulas were collected and kept in 100 μ l cryopreservation media (Gibco, USA) at -20°C until used in gene expression analysis.

E. Gene Expression Analysis

All collected morulas were processed for gene expression analysis using QuantiGene Plex assay (QGP) (Affymetrix, USA) at i-DNA Biotechnology (M) Sdn. Bhd., Kuala Lumpur, Malaysia. The genes being analyzed were *Pik3ca*, *Pik3cb*, *PDK1*, *Akt1*, *PTEN* and *GSK3 β* . The obtained raw data on the median fluorescence intensity (MFI) value were normalized against the hypoxanthine-guanine phosphoribosyl transferase 1 (*Hprt1*) gene (reference gene) and against control value. Fold-change values were statistically analyzed using one-way ANOVA to identify the significant (p<0.05) change in the gene expressions between the treatment and control groups.

III. RESULTS

A. Number of Morula

The number of morula produced following respective treatments is shown in Table II and Fig. 2. Present data shows a significant increase (p<0.05) in the number of morula in G2-G4 compared to control group (G1).

TABLE II
NUMBER OF MORULA RETRIEVED FOLLOWING *IN VITRO* CULTURE

Groups (Treatment)	Number of morula (Mean \pm SEM)
G1-Corn oil tocopherol stripped (Control)	14.61 \pm 0.25
G2- δ -TCT mixture (90% δ :10% γ)	27.32 \pm 0.23
G3-Pure δ -TCT (delta >98% purity)	25.42 \pm 0.21
G4- α -TOC	27.21 \pm 0.34

B. PI3K/Akt Gene Fold Change Value

Fold change value of PI3K/Akt gene expressions as shown in Fig. 3 indicate total inhibition of *Pik3ca*, *PTEN* and *GSK3 β* expressions in all treatment groups. Expression of *Pik3cb* declined at 50% (G2), 43% (G3) and 65% (G4). Meanwhile expression of *PDK1* significantly increased (p<0.05) in comparison to G1 with the value of 2.75-fold (G2), 3.07-fold (G3) and 3.59-fold (G4). *Akt1* gene expression however was decreased in G2 & G3, but increased by 71% in G4.

IV. DISCUSSION

Present data provided a novel finding on the ability of δ -TCT(s) to enhance the production of morula in mice (Table II, Fig. 2). In comparison to G1, the increases in the number of morula in G2 & G3 are similar to G4, which was supplemented with α -TOC. Previous studies have reported that α -TOC possess the ability to enhance embryonic development [15], [16]. From the present study, it is clear that δ -TCT(s) also possess the similar potential as α -TOC in enhancing the development of morula in mice.

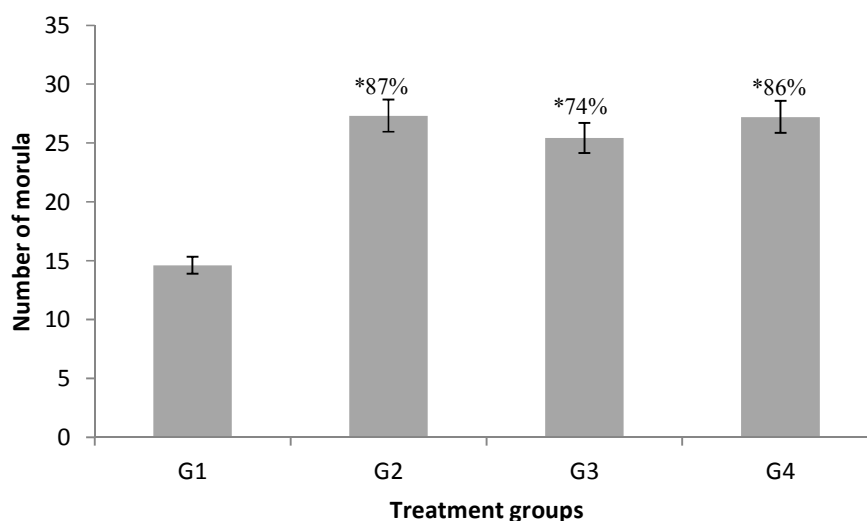

Fig. 2 Number of morula in each treatment groups. Numbers above bars indicate the value differences (in percentage) between the treatment groups and control (G1)

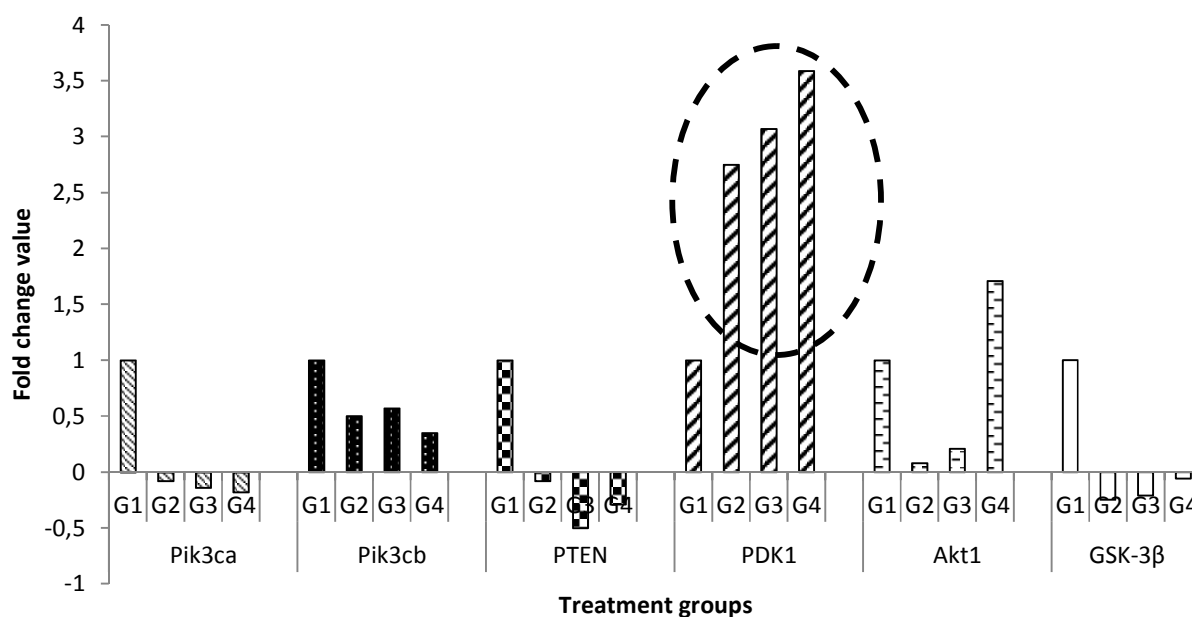

Fig. 3 Differences in fold change value of PI3K/Akt genes in morula. *PDK1* is highly expressed in all treatment groups, while *Pik3ca*, *PTEN* and *GSK3β* are totally inhibited. *Pik3cb* is downregulated and *Akt1* shows some changes between the groups

Data on the gene expression analysis shows that the increase in morula production in G2-G4 was associated with the high expression of *PDK1* gene following respective treatment of δ -TCT(s) and α -TOC (Fig. 3). In PI3K/Akt signaling pathway, the PI3-kinase (PI3K) is produced through heterodimerization of p85 regulatory and p110 (*Pik3ca* & *Pik3cb*) catalytic subunits [17]. PI3-kinase functions to produce PtdIns [3], [4] P2 (PIP2) and PtdIns [3]-[5] P3 (PIP3). PIP2 and PIP3 are essential in PI3K/Akt pathway where both serve as second messengers [18]. PDK1 is known as a ‘master

kinase’, whose activation is required in mouse embryonic development through phosphorylation and activation of several other kinases including *Akt1* [19]. PDK1 possesses a regulatory domain called Pleckstrin Homology (PH) domain that binds to PIP3. This binding of PDK1 to PIP3 is essential for efficient activation of *Akt1* [18]. *Akt1* also has an N-terminal PH domain that interact with equal affinity with PIP2 and PIP3, in which this binding induced a conformational change that converts *Akt1* into a substrate that can be activated by PDK1 [20] (Fig. 4). Therefore, present data suggest that

following high expression of PDK1 in G2-G4 (supplemented with δ -TCT(s) and α -TOC), the interaction of PDK1 with PIP3 and the subsequent activation of *Akt1* might increase the PI3K/Akt activity and results in the increased number of morula in G2-G4. Besides, the increase in the number of morula produced in G2 and G3 with the downregulated *Akt1* might be explained by two possibilities. First is that PDK1 proceeds with cell proliferation without the presence of activated *Akt1*, a mechanism known as *Akt1*-independent signaling [21]. The second possibility might be that downregulation of *Akt1* results in the increased production of

PIP3 [22]. In the condition of aberrantly activated PI3K/Akt pathway, PDK1 functions as a cellular sensor that balances the production of basal PIP3 at sufficient levels for survival and below the threshold of being harmful to the cells [22]. Thus, the high level of PDK1 in G2-G4 might help in the survival (high production) of morula. Nevertheless, the high number of morula production even in the condition of lacking *Akt1* expression following treatment with δ -TCT(s) need to be further studied to better understand the mechanism of proliferation influenced by δ -TCT.

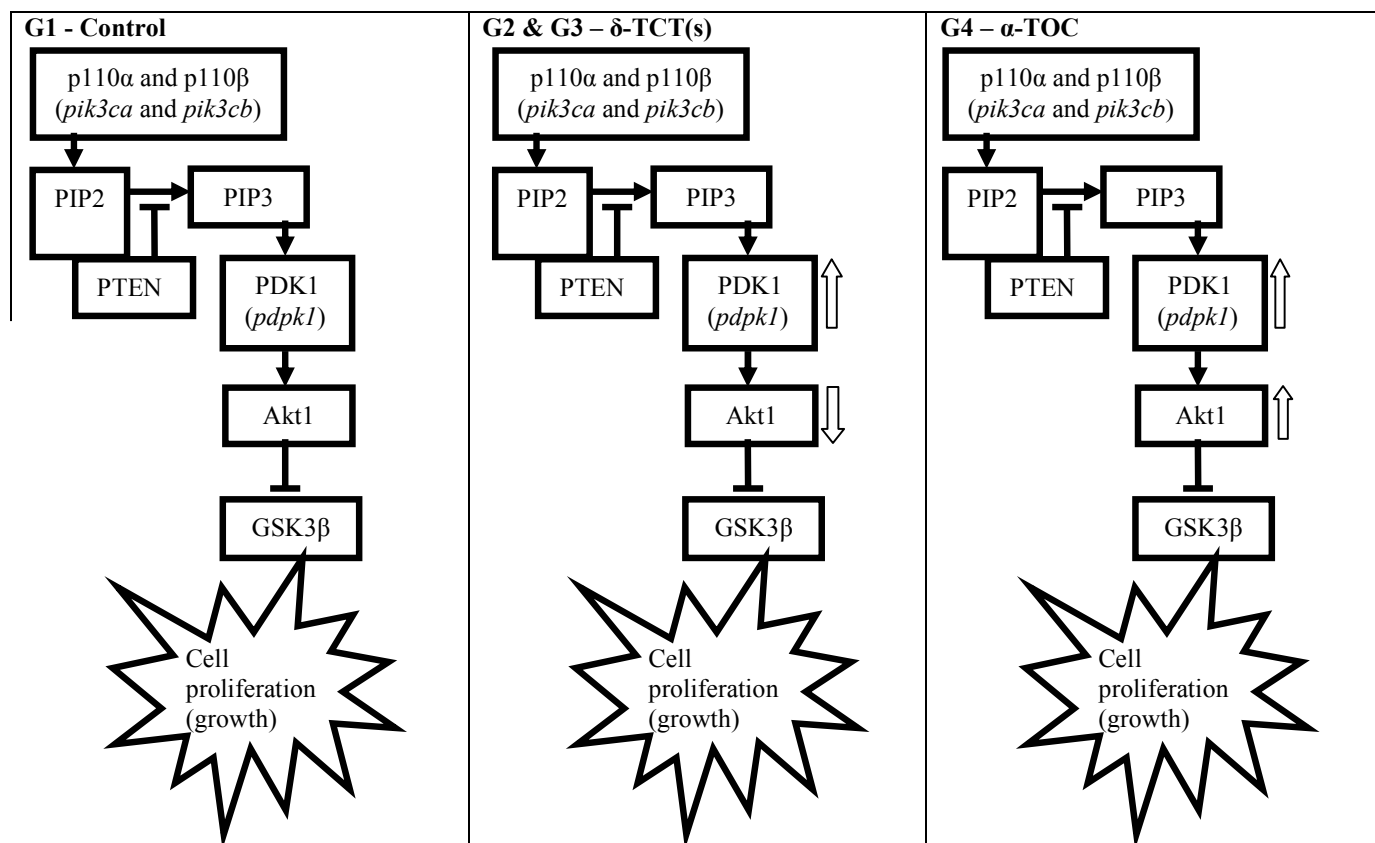

Fig. 4 Schematic diagram of PI3K/Akt pathway in morula. *PDK1* was upregulated in all treatment groups, but *Akt1* showed pattern of downregulation in G2 and G3, and upregulation in G4

ACKNOWLEDGMENT

A special thanks to Ministry of Education, Malaysia and Research Management Institute (RMI), UiTM Shah Alam, Selangor, Malaysia for all the support and assistance. Also a great thanks to American River Nutrition Inc., USA for providing the δ -TCT samples.

REFERENCES

- [1] S. Sherman, Lawrence, et al. Human embryology. 3rd ed. Elsevier Publications, 2001.
- [2] Marcader, Amparo et al. (2008) "Human embryo culture". in Essential stem cell methods, Lanza, Robert & I. Klimanskaya, Ed. Academic Press, 2008, pp343.
- [3] C. Lingyi, W. Dekun, W. Zhaoting, M. Liping, and Q. D. George, "Molecular basis of the first cell fate determination in mouse embryogenesis," Cell Res., vol. 20, pp. 982-993, 2010.
- [4] J. K. Riley, M. O. Carayannopoulos, A. H. Wyman, M. Chi, C. K. Ratajczak, and K. H. Moley, "The PI3K/Akt pathway is present and functional in the preimplantation mouse embryo," Dev. Biol., vol. 284, pp.377-386, 2005.
- [5] S. R. Datta, A. Brunet, and M. E. Greenberg, "Cellular survival: A play in three Akts," Genes Dev., vol. 13, pp.2905-2927, 1999.
- [6] F. J. A. Vara, E. Casado, J. de Castro, P. Cejas, C. Belda-Iniesta, and M. Gonzalez-Baron, "PI3K/Akt signaling pathway and cancer," Cancer Treat.Rev. vol. 30, no.2, pp.193-204, 2004.
- [7] M. A. Lawlor, and D. R. Alessi, "PKB/Akt: a key mediator of cell proliferation survival and insulin responses?" J. Cell Sci., vol. 114, pp.2903-10, 2001.
- [8] D. A. Butterfield, A. Castegna, J. Drake, G. Scapagnini, and V. Calabrese "Vitamin E and neurodegenerative disorders associated with oxidative stress," Nutr. Neurosci. vol. 5, pp.229-239, 2002.
- [9] T. Koga, P. Kwan, L. Zubik, C. Ameho, D. Smith, and M. Meydani, "Vitamin E supplementation suppresses macrophage accumulation and endothelial cell expression of adhesion molecules in the aorta of hypercholesterolemic rabbits," Atherosclerosis, vol. 176, no. 2, pp. 265-272, 2004.

- [10] W. N. Yap, P. N. Chang, H. Y. Han, D. T. W. Lee, M. T. Ling, Y. C. Wong, and Y. L. Yap, " γ -Tocotrienol suppresses prostate cancer cell proliferation and invasion through multiple-signalling pathways," *British Journal of Cancer*, vol. 99, no. 11, pp.1832-1841, 2008.
- [11] A. Nasibah, M. H. Rajikin, M. N. K. Nor-Ashikin, and A. S. Nuraliza, "Tocotrienol improves the quality of impaired mouse embryos induced by corticosterone," in *Conf. Rec. 2012 Symposium on Humanities, Science and Engineering Research (SHUSER2012)*, pp.135-138.
- [12] A. Nasibah, M. H. Rajikin, M. N. K. Nor-Ashikin, and A. S. Nuraliza, "Effects of tocotrienol supplementation on pregnancy outcome in mice subjected to maternal corticosterone administration," *Journal of Oil Palm Research*, vol. 24, pp. 1550-1558, 2012b.
- [13] Y. S. Kamsani, M. H. Rajikin, M. N. K. Nor-Ashikin, A.S. Nuraliza, and A. Chatterjee, "Nicotine-induced cessation of embryonic development is reversed by γ -tocotrienol in mice," *Med. Sci. Monit. Basic Res*, vol. 19, pp. 87-92, 2013.
- [14] E. Lee, S. H. Min, B. S. Song, J. Y. Yeon, J. W. Kim, J. H. Bae, S. Y. Park, Y. H. Lee, S. U. Kim, D. S. Lee, K. T. Chang, and D.B. Koo, "Exogenous gamma-tocotrienol promotes preimplantation development and improves the quality of porcine embryos," *Reprod. Fertil. Dev.*, DOI 10.1071/RD13167, 2014.
- [15] I. Miclea, M. Zhan, V. Miclea, A. Hettig, J. Roman, and F. Ghiuru, "Influence of alpha-tocopherol on swine embryo development," *Bulletin UASVM Animal Science and Biotechnologies*, vol. 67, pp. 1-2, 2010.
- [16] R. Natarajan, M. S. Bhawani, and M. Deecaraman, "Effect of α -tocopherol supplementation on in vitro maturation of sheep oocytes and in vitro development of preimplantation sheep embryos to the blastocyst stage," *J. Assist. Reprod. Genet.* vol. 27, no. 8, pp. 483-490, 2010.
- [17] D. A. Fruman, R. E. Meyers, and L. C. Cantley, "Phosphoinositide kinases," *Annual Review of Biochemistry*, vol. 67, pp. 481-507, 1998.
- [18] J. R. Bayascas, "Dissecting the role of the 3-phosphoinositide-dependent protein kinase-1 (PDK1) signaling pathways," *Cell Cycle*, vol. 7, no. 19, pp. 2978-82, 2008.
- [19] C. O'Neill, "Phosphatidylinositol 3-kinase signaling in mammalian preimplantation embryo development," *Reprod.* vol. 136, pp. 147-156, 2008.
- [20] C. C. Milburn, M. Deak, S. M. Kelly, N. C. Price, D. R. Alessi, and A. D. M. Van, "Binding of phosphatidylinositol3,4,5-triphosphate to the pleckstrin homology domain of protein kinase B induces a conformational change," *Biochem J.* vol. 1375, no. 3, pp. 531-538, 2003.
- [21] K. George, and J. W. Michael, "Akt-dependent and -independent survival signaling pathways utilized by insulin-like growth factor," *Mol. Cell Biol.* vol. 18, no. 11, pp. 6711-6718, 1998.
- [22] A. M. Dieterle, P. Böhler, H. Keppeler, S. Alers, N. Berleth, S. DrieBen, N. Hieke, S. Pietkiewicz, A.S. Löffler, C. Peter, A. Gray, N.R. Leslie, H. Shinohara, T. Kurosaki, M. Engelke, J. Wienands, M. Bonin, S. Wesselborg and B. Stork, "PDK1 controls upstream PI3K expression and PIP3 generation," *Oncogene.* vol. 33. no. 23. pp. 3043 – 3053, 2014.