

Comparison of Transparent Nickel Doped Cobalt Sulfide and Platinum Counter Electrodes Used in Quasi-Solid State Dye Sensitized Solar Cells

Dimitra Sygkridou, Dimitrios Karageorgopoulos, Elias Stathatos, Evangelos Vitoratos

Abstract—Transparent nickel doped cobalt sulfide was fabricated on a $\text{SnO}_2:\text{F}$ electrode and tested as an efficient electrocatalyst and as an alternative to the expensive platinum counter electrode. In order to investigate how this electrode could affect the electrical characteristics of a dye-sensitized solar cell, we manufactured cells with the same TiO_2 photoanode sensitized with dye (N719) and employing the same quasi-solid electrolyte, altering only the counter electrode used. The cells were electrically and electrochemically characterized and it was observed that the ones with the Ni doped CoS_2 outperformed the efficiency of the cells with the Pt counter electrode (3.76% and 3.44% respectively). Particularly, the higher efficiency of the cells with the Ni doped CoS_2 counter electrode (CE) is mainly because of the enhanced photocurrent density which is attributed to the enhanced electrocatalytic ability of the CE and the low charge transfer resistance at the CE/electrolyte interface.

Keywords—Counter electrodes, dye-sensitized solar cells, quasi-solid state electrolyte, transparency.

I. INTRODUCTION

A DSSC is composed of a nanocrystalline film of a wide band gap semiconductor oxide deposited on a $\text{SnO}_2:\text{F}$ transparent conductive electrode (negative electrode), a broad absorption spectrum dye adsorbed and chemically anchored on the semiconductor oxide's surface, an electrolyte bearing a redox couple, usually I^-/I_3^- , and a counter electrode on a $\text{SnO}_2:\text{F}$ electrode (positive electrode). The material of choice for the counter electrode is in most cases platinum, as it can be easily prepared by thermal decomposition of chloroplatinic acid and is a great electrocatalyst [1]. However extensive research has been devoted in replacing platinum with a different catalyst that also bears good catalytic properties, abundance and lower material cost. Other suitable materials that have been used and tested include carbonaceous materials, such as graphite [2], graphene [3], [4], multi-walled carbon nanotubes (MWCNT) [5], [6], conjugated polymers [7]-[9] and inorganic materials such as cobalt sulfides [10]-[13]. In an attempt not to compromise between the counter electrode's transparency and its electrocatalytic ability, we decided to

investigate the case of a nickel doped cobalt sulfide cathode [14]. Nickel doped cobalt sulfide counter electrode was chosen as an alternative CE based on the results reported from S. Srinivasa Rao et al. suggesting an enhancement of DSSCs' power conversion efficiency when compared with cell's employing Pt CE [14]. The cells that were used from Srinivasa Rao et al. to reach to these conclusions employed liquid I^-/I_3^- electrolyte. In order to examine the effect of this CE on the electrical characteristics of DSSCs employing a quasi-solid state electrolyte we used a similar nickel doped cobalt sulfide synthesis. The materials that were used to fabricate the nickel doped cobalt sulfide counter electrode were substantially cheaper than platinum and the deposition method used didn't require annealing at high temperature, which suggests that this counter electrode could be also used for manufacturing flexible DSSCs.

In this work, we investigate an alternative transparent counter electrode composed of nickel doped cobalt sulfide which we afterwards used for the fabrication of quasi-solid state dye sensitized solar cells. The electrical characteristics of these cells are compared against cells employing platinumized counter electrodes through photocurrent-voltage measurements and electrochemical impedance spectroscopy (EIS).

II. MATERIALS AND METHODOLOGY

A. Materials

Commercially available titanium(IV) butoxide (TTBU, 97%), lithium iodide, iodine, 1-methyl-3-propylimidazolium iodide, tert-butyl pyridine, guanidine thiocyanate, chloroplatinic acid hexahydrate (H_2PtCl_6), O, O'-Bis(2-aminopropyl) polypropylene glycol-block-polyethylene glycol-block-polypropylene glycol (Jeffamine® ED-600), 3-isocyanatopropyltriethoxysilane, thioacetamide (ACS reagent $\geq 99.0\%$), nickel(II) acetate tetrahydrate (98%) and all solvents were purchased from Sigma-Aldrich and used as received. Thiourea and cobalt(II) nitrate hexahydrate were purchased from Penta and used as received. 3-Cis-diisothiocyanato-bis(2,2'-bipyridyl-4,4'-dicarboxylato) ruthenium(II) bis (tetra butyl ammonium), N719 was purchased from Solaronix S.A, Switzerland. $\text{SnO}_2:\text{F}$ transparent conductive electrodes (FTO, TEC8) 8 Ohm/square were purchased from Pilkington NSG Group. Commercial ultra-pure titanium butoxide (TTBU, 97%, Aldrich), Triton X-100 (polyethylene glycol p-tert-octylphenyl ether) surfactant (99.8%, Fisher Scientific),

Dimitra Sygkridou, Dimitrios Karageorgopoulos, and Evangelos Vitoratos are with the Physics Department, University of Patras, 26500, Greece (e-mail: dsygridou@upatras.gr, dkarageorgop@upatras.gr, vitorato@physics.upatras.gr).

Elias Stathatos is with the Electrical Engineering Department, Technological-Educational Institute of Western Greece, 26334 Patras, Greece (corresponding author to provide phone: 0030-2610-369242; e-mail: estathatos@teiwest.gr).

glacial acetic acid (AcOH, Aldrich) were used to make precursor TiO_2 sols. Titania powder P25 was provided by Degussa, (Germany, 30% Rutile and 70% Anatase).

B. Preparation of TiO_2 Photoanodes Sensitized with Dye

TiO_2 films were fabricated in two steps. A thin layer of TiO_2 was first deposited on FTO glass substrates as blocking layer via sol-gel method following a previously reported procedure [15]. Briefly, for 5.4 ml solution, 0.72 g of Triton X-100 was mixed with 4 ml of ethanol, followed by addition of 0.4 ml of glacial acetic acid and 0.37 ml of titanium butoxide under vigorous stirring. After a few minutes stirring, the solution was deposited on the FTO glasses with a spin coating device (Spin150, APT Automation) at 1200 rpm for 10s. The films were heated up to 500°C for 30 minutes using 20°C/min heating ramp rate. The procedure was applied for the deposition of only two TiO_2 layers while the films thickness was approximately 150nm. Then, an additional thicker layer was coated on top of the above layers, made of nanocomposite TiO_2 paste using P25 commercial powder by doctor blade technique, followed by heating to 500°C. The fabrication of TiO_2 paste was as follows: 3 g of Degussa P25 was mixed with 0.5 ml of acetic acid in a mortar for about 3 min. After that, 2.5 ml of millipore water and 17.5 ml of ethanol were alternately added to break all TiO_2 aggregates and form a homogenous solution. The solution was transferred to a crucible with 50 ml of ethanol and was mixed with 10 g of terpineol and an amount of ethyl cellulose. The solution was ultrasonicated for about 2 minutes and then the crucible was placed in a rotary evaporator at 40-45°C to remove the excessive solvent and form the TiO_2 paste. Finally the TiO_2 films were immersed in an ethanol/acetonitrile (1/1 v/v) solution of N719 (the dye concentration was 4×10^{-4} M) in order to sensitize the TiO_2 electrode in the visible. Excessive dye molecules that weren't adsorbed on the TiO_2 surface were removed by rinsing with acetonitrile.

C. Preparation of the Counter Electrodes

An alternative counter electrode (CE) was prepared and used in quasi-solid state dye-sensitized solar cells to compare it against the commonly used Pt CE. The counter electrode that was fabricated was a nickel doped cobalt sulfide (Ni doped CoS_2) as it is suggested in literature that this CE can substitute and perhaps supersede the platinum counter electrode. The nickel doped cobalt sulfide counter electrode was fabricated through the chemical bath deposition (CBD) method. For the solution synthesis we used 0.1 M cobalt (II) nitrate hexahydrate, 0.2 M thiourea, 0.2 M thioacetamide in 3 ml of Millipore water. To the above solution we added 0.0471 gr of nickel(II) acetate tetrahydrate to complete the doping. The FTO glasses are placed horizontally into a closed glass bottle containing the solution and then the glass bottle is placed in a furnace at 90°C for 2 hours. The parts of the FTO glass that we didn't want to apply the CE solution were covered with an insulating tape, which was removed after the deposition. When the deposition was completed, the FTO glasses were removed from the glass bottle and were rinsed

using Millipore water and ethanol. Finally, the FTO glasses annealed at 60°C for half an hour. The platinized FTO glasses were made by casting a few drops of a H_2PtCl_6 solution (5mg/1ml of ethanol) followed by heating at 500°C for 10 minutes.

D. Quasi-Solid Electrolyte Preparation

In the construction of the solar cells a quasi-solid state electrolyte was used. This was chosen as a promising approach to DSSC technology as it combines the high ionic conductivity of liquids while it reduces the risk of leaks and minimizes sealing problems in the cells. For the gel electrolyte applied to the DSSCs, we used a hybrid organic-inorganic material [16], [17]. Briefly, O, O'-Bis(2-aminopropyl) polypropylene glycol-block-polyethylene glycol-block-polypropylene glycol (Jeffamine® ED-600), of molecular weight 600 and 3-isocyanatopropyltriethoxysilane (ICS; molar ratio ICS/diamine=2) react in a vessel (acylation reaction), producing urea connecting groups between the polymer units and the inorganic part. The gel electrolyte was synthesized by the following procedure: 0.0788 grams of the functionalized alkoxide precursor were dissolved in 0.2 g of sulfolane and 0.1 g of methoxypropionitrile under vigorous stirring. Then, 0.046 g AcOH were added followed by 0.015 g 1-methyl-3-propylimidazolium iodide, 0.015 g LiI and 0.0075 g I_2 . Finally, the electrolyte solution was completed by adding 0.0255 g tert-butyl pyridine and 0.00445 g guanidine thiocyanate. After six hours stirring, one drop of the obtained sol was placed on the top of the titania electrode with adsorbed dye molecules and a slightly platinized FTO counter electrode was pushed by hand on the top. The two electrodes tightly stuck together by Si-O-Si bonds developed by the presence of the hybrid material.

E. Characterization Techniques

For the J-V curves, the samples were illuminated with Xe light using a Solar Light Co. solar simulator (model 16S-300) equipped with AM 0 and AM 1.5 direct Air Mass filters to simulate solar radiation at the surface of the earth. The light intensity was kept constant at 1000 W/m^2 measured with a Newport power meter (Model 843-R). Finally, the J-V curves were recorded by connecting the cells to a Keithley Source Meter (model 2601A) which was controlled by Keithley computer software (LabTracer). The cells' total active area was 1 cm x 1 cm, but for the J-V curves an appropriate black mask was used, limiting the cell's active area to 0.514 cm x 0.514 cm. For each case, we made two devices which were tested under the same conditions in order to avoid any misleading estimation of their efficiency. Cell performance parameters, including short-circuit current density (J_{SC}), open circuit voltage (V_{OC}), maximum power (P_{max}), fill factor (FF) and overall cell conversion efficiency, were measured and calculated from each J-V characteristic curve.

Electrochemical impedance spectroscopy measurements (EIS) were carried out under illumination using the same Xe light source that was used for the J-V curves. EIS measurements were performed without the use of a mask with

Metrohm Autolab 3.v potentiostat galvanostat (Model PGSTAT 128N) through a frequency range of 100 kHz-0.01 Hz using a perturbation of ± 10 mV over the open circuit potential. Experimental data are presented by scattering symbols while lines represent the fitted plots obtained using Nova 1.10 software.

III. RESULTS AND DISCUSSION

A. Solar Cells' Performance

Fig. 1 presents the current density-voltage (J - V) characteristic curves of quasi solid-state dye sensitized solar cells with the different counter electrodes tested. All J - V measurements were carried out using a mask with an aperture area of 0.514 cm x 0.514 cm. The electrical parameters measured and calculated for all cells are summarized in Table I. Fig. 2 shows a picture which corroborates the counter electrodes' transparency.

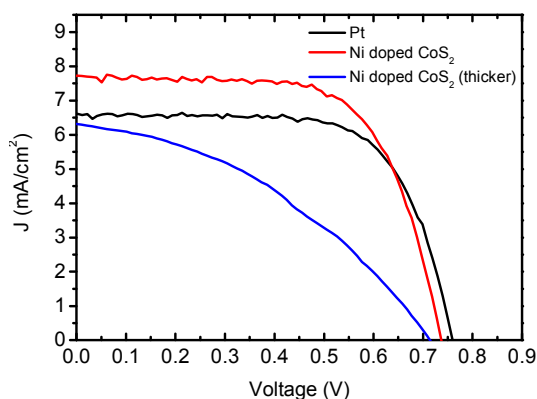

Fig. 1 Photocurrent density-voltage characteristic curves of dye-sensitized solar cells with different counter electrodes

In Fig. 1 there are two curves illustrated corresponding to cells employing nickel doped cobalt sulfide counter electrodes. At some point while preparing the Ni doped CoS_2 counter electrodes one of the cap of the glass bottles popped out resulting in the evaporation of some amount of the solvent (Millipore water), making the solution more dense, which resulted in a thicker and less transparent counter electrode. However, we decided to use both the thinner and the thicker nickel doped counter electrode for cells to compare it against each other.



Fig. 2 Platinum transparent counter electrode (on the left) and nickel doped cobalt sulfide counter electrode (on the right)

It can be seen that the cell with the thinner nickel doped cobalt sulfide counter electrode has a higher J_{sc} value

compared with the one employing the Pt CE. In general, cobalt sulfide counter electrodes have lower conductivity compared with Pt and lower electrocatalytic ability for reducing I_3^- . However, the use of small amount of nickel as a doping agent for the CoS_2 seems to enhance the catalytic ability and increase the current density through the reduction of the energy losses. The cells with the thicker nickel doped cobalt sulfide counter electrode were outperformed by the cells with platinum counter electrode and we didn't take them into account for the remaining measurements and calculations.

The V_{oc} values recorded for the different cells had small variations as expected, since the same anode and electrolyte was used for manufacturing the cells. Finally, the fill factor values were close, almost the same (0.68 and 0.67 for the DSSC with the Pt and the Ni doped CoS_2 counter electrode respectively).

TABLE I
ELECTRICAL CHARACTERISTICS OF DSSCS EMPLOYING DIFFERENT COUNTER ELECTRODES

Counter Electrode	J_{sc} (mA/cm ²)	V_{oc} (V)	FF	η (%)
Pt	6.6	0.764	0.68	3.44
Ni doped CoS_2	7.8	0.733	0.67	3.76

The dark current suppression was also examined to perceive the extent of the back electron transfer. Fig. 3 shows that dark current density in the cells made with the different counter electrodes. The onset of the dark current for the DSSCs fabricated with the platinum CE occurred at lower voltage compared with the cells employing the nickel doped CoS_2 counter electrode, which was an additional indication for the better performance of the cells with the latter counter electrode.

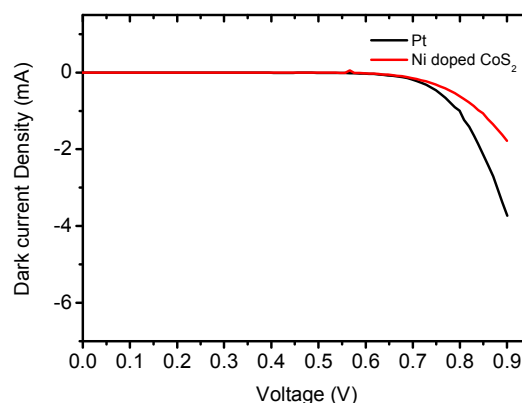

Fig. 3 Dark current-voltage characteristic curves of dye-sensitized solar cells with different counter electrodes

B. Electrochemical Impedance Spectroscopy (EIS)

Figs. 4 and 6 show the Nyquist and Bode plots obtained from cells with the different counter electrodes respectively. The first semicircle, starting from left to right, corresponds to the CE/electrolyte interface, R_{CE} . The charge transfer resistance at the counter electrode (R_{CE}) is represented as a semicircle in the impedance spectra and a peak in the Bode phase angle plot (peak at high frequency). The resistance

element related to the response in the intermediate frequency represents the charge transport at the TiO₂/dye/electrolyte interface (R_{tr}) and shows diode like behavior. The semicircle at the low frequency, which is attributed to the diffusion of redox species in the electrolyte (R_{dif}), was small and not well distinguished, indicating a fast diffusion. Finally, the intercept of the horizontal axis stands for the resistance of the sheet resistance of the FTO substrate and the contact resistance of the FTO/TiO₂ (R_h) [18], [19].

The total series resistance of the cell can be calculated using (1):

$$R_S = R_h + R_{CE} + R_{dif} \quad (1)$$

The equivalent circuits which were used to fit the experimental data are presented in Fig. 5. For electrodes having a rough surface the capacitance element in Fig. 5 (a) is replaced by a constant phase element (CPE, Q) which depends on the parameters Y_o and N (Fig. 5 (b)) [20]. According to instrument software's manual Y_o is the admittance of an ideal capacitance while N is an empirical constant ranging from 0 to 1. It is possible to convert a CPE element, which is in parallel with a resistance, to a pseudo capacitance using (2):

$$C_{pseudo} = Y_o^{1/N} \cdot R \left(\frac{1}{N} - 1 \right) \quad (2)$$

As shown in (2) for $N=1$ the CPE element describes a pure capacitor, while for $N=0$ an ideal resistor. Moreover for $N=0.5$ the CPE element is equivalent to the Warburg element often used to describe the diffusion in the electrolyte. It is generally though to arise from the lack of homogeneities in the electrode-material system. The fitted parameters are presented in Table II.

The fitted parameters are summarized in Table II. The fact that the only difference between the cells was the counter electrode that was used, the main variations are expected to be noticed at the EIS parameters that correspond to that interface, in other words, at the CE/electrolyte interface. The RCE was smaller for the cells with the nickel doped CoS₂ counter electrode indicating its better electrocatalytic performance. Moreover, difference was also observed at the R_{tr} values, while the total series resistance was calculated using (1) and the results were comparable. Specifically, R_s was 23.15 Ω for the cell with the platinum counter electrode, whereas R_s was 23.56 Ω for the cell with the Ni doped CoS₂ counter electrode.

TABLE II
ELECTROCHEMICAL IMPEDANCE SPECTROSCOPY FITTED PARAMETERS FOR DSSCs WITH DIFFERENT COUNTER ELECTRODES

CE	R_h (Ω)	R_{CE} (Ω)	C_{CE} (F) (10^{-4})	R_{tr} (Ω)	C_{tr} (F) (10^{-3})	R_{dif} (Ω)	C_{dif} (F) (10^{-1})
Pt	14.4	6.62	0.141	20.6	1.25	2.13	0.0198
Ni doped CoS ₂	14.6	4.46	0.138	12.3	1.28	4.5	0.104

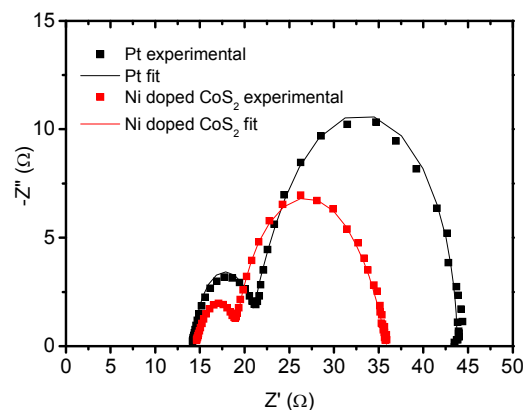

Fig. 4 Impedance spectra of dye-sensitized solar cells with different counter electrodes measured at open circuit voltage at 1 sun illumination

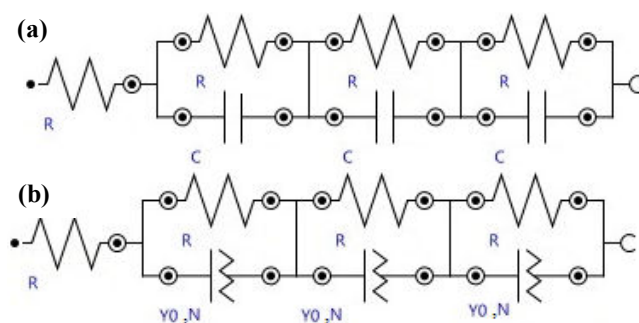

Fig. 5 DSSCs equivalent circuits (a) R(RC)(RC)(RC) and (b) R(RQ)(RQ)(RQ) used to fit the experimental data from the EIS measurements

The electron lifetime can be calculated from the mid frequency peak of the Bode plots presented in Fig. 6 using (3). According to the results presented in Table III, Pt had a higher electron lifetime than Ni doped CoS₂, which isn't in accordance to the J_{sc} values obtained from J-V curves.

$$\tau = \frac{1}{2 \cdot \pi \cdot f} \quad (3)$$

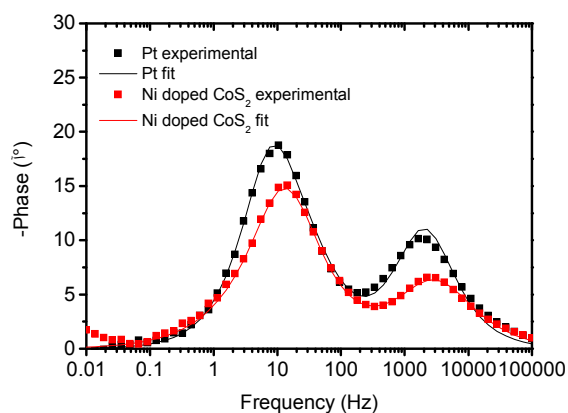

Fig. 6 Bode phase plots of dye-sensitized solar cells with different counter electrodes measured at open circuit voltage at 1 sun illumination

The longest electron lifetime of the Pt cells is due to the lower recombination of the injected electrons. Namely, the higher J_{sc} values obtained for the Ni doped CoS_2 cells aren't attributed to a lower recombination, rather to the increment of the CE's electrocatalytic ability and the low charge transfer resistance at the CE/electrolyte interface.

TABLE III
ELECTRON LIFETIME

Counter electrode	f (Hz)	τ (ms)
Pt	9.015	17.65
Ni doped CoS_2	13.14	12.11

IV. CONCLUSIONS

Transparent nickel doped cobalt sulfide counter electrode was fabricated and compared against platinum. The fabrication process of the former might be more time consuming than the latter, however the Ni doped cobalt sulfide synthesis requires low temperature thermal treatment, which can also be utilized for manufacturing flexible DSSCs and substantial lower cost. The cells that were manufactured employing the Ni doped CoS_2 counter electrode achieved the highest efficiency of 3.76%, while the ones with the platinum had a highest efficiency of 3.44%. Specifically, an increased photocurrent density value was obtained for cells with Ni doped CoS_2 counter electrode due to the low charge transfer resistance at the CE/electrolyte interface. Finally, over time, it was noted that the new transparent counter electrode worked well in combination with the quasi-solid state electrolyte without showing evidence of detachment between the two electrodes.

ACKNOWLEDGMENTS

"COOPERATION 2011 - Partnerships of Production and Research Institutions in Focused Research and Technology Sectors" of the Operational Programme "Competitiveness and Entrepreneurship (EPAN II) and regions in transition", co-financed by the European Fund regional Development Fund (ERDF) of the European Union and National Resources, no.11SYN-7-298.

REFERENCES

- [1] Z. Tang, J. Wu, M. Zheng, J. Huo, Z. Lan, "A microporous platinum counter electrode used in dye-sensitized solar cells", *Nano Energy*, vol. 2, pp. 622-627, September 2013.
- [2] G. Veerappan, K. Bojan, S.-W. Rhee, "Sub-micrometer-sized graphite as a conducting and catalytic counter electrode for dye-sensitized solar cells", *ACS Appl. Mater. Interfaces*, vol. 3, pp. 857-862, February 2011.
- [3] P. K. Singh, U. Singh, B. Bhattacharya, H.-W. Rhee, "Electrochemical synthesis of graphene oxide and its application as counter electrode in dye-sensitized solar cell", *J. of Renewable and Sustainable energy*, vol. 6, pp. 013125, January 2014.
- [4] H. Choi, H. Kim, S. Hwang, Y. Han, M. Jeon, "Graphene counter electrodes for dye-sensitized solar cells prepared by electrophoretic deposition", *J. Mater. Chem.*, vol. 21, pp. 7548-7551, April 2011.
- [5] S. A. Almohsin, M. Mohammed, Z. Li, M.A. Thomas, K. Y. Wu, J. B. Cui, "Multi-walled carbon nanotubes as a new counter electrode for dye-sensitized solar cells", *J. of Nanoscience and Nanotechnology*, vol. 12, pp. 2374-2379, March 2012.
- [6] H. J. Choi, H. H. Gong, J.-Y. Park, S. C. Hong, "Characteristics of dye-sensitized solar cells with surface-modified multi-walled carbon

- nanotubes as counter electrodes", *J. of Materials Science*, vol. 48, pp. 906-912, January 2013.
- [7] J. Xia, L. Chen, S. Yanagida, "Application of polypyrrole as a counter electrode for a dye-sensitized solar cell", *J. Mater. Chem.*, vol. 21, pp. 4644-4649, March 2011.
- [8] T. Makris, V. Dracopoulos, T. Stergiopoulos, P. Lianos, "A quasi solid-state dye-sensitized solar cell made of polypyrrole counter electrodes", *Electrochim. Acta*, vol. 56, pp. 2004-2008, November 2010.
- [9] J. Zhang, T. Hreid, X. Li, W. Guo, L. Wang, X. Shi, H. Su, Z. Yuan, "Nanostructured polyaniline counter electrode for dye-sensitized solar cells: Fabrication and investigation of its electrochemical formation mechanism", vol. 55, pp. 3664-3668, April 2010.
- [10] C.-W. Kung, H.-W. Chen, C.-Y. Lin, K.-C. Huang, R. Vittal, K.-C. Ho, "CoS acicular nanorod arrays for the counter electrode of an efficient dye-sensitized solar cell", *ACS Nano*, vol. 6, pp. 7016-7025, July 2012.
- [11] S. Srinivasa Rao, C.V.V.M. Gopi, S.-K. Kim, M.-K. Son, M.-S. Jeong, A. Dennyson Savariraj K. Prabakar, H.-J. Kim, "Cobalt sulfide thin film as an efficient counter electrode for dye-sensitized solar cells", *Electrochim. Acta*, vol. 133, pp. 174-179, April 2014.
- [12] J.-Y. Lin, J.-H. Liao and T.-C. Wei, "Honeycomb-like CoS counter electrodes for transparent dye-sensitized solar cells", *Electrochem. Solid-State Lett.*, vol. 14, pp. D41-D44, February 2011.
- [13] M. Wang, A. M. Anghel, B. Marsan, N. L. C. Ha, N. Pootrakulchote, S. M. Zakeeruddin, M. Grätzel, "CoS Supersedes Pt as Efficient electrocatalyst for triiodide reduction in dye-sensitized solar cells", *J. Am. Chem. Soc.*, vol. 131, pp. 15976-15977, October 2009.
- [14] H.-J. Kim, C.-W. Kim, D. Punnoose, C. V. V. M. Gopi, S.-K. Kim, K. Prabakar, S. Srinivasa Rao, "Nickel doped cobalt sulfide as a high performance counter electrode for dye-sensitized solar cells", *Applied Surface Science*, vol. 328, pp. 78-85, December 2014.
- [15] E. Stathatos, P. Lianos, C. Tsakiroglou, "Highly efficient nanocrystalline titania films made from organic/inorganic nanocomposite gels", *Microporous and Mesoporous Materials*, vol. 75, pp. 255-260, April 2004.
- [16] E. Stathatos, "Organic-inorganic nanocomposite materials prepared by the sol-gel route as new ionic conductors in quasi solid state electrolytes", *Ionics*, vol. 11, pp. 140-145, November 2004.
- [17] E. Stathatos, P. Lianos, U. L. Stangar, B. Orel, and P. Judeinstein, "Structural study of hybrid organic/inorganic polymer gels using time-resolved fluorescence probing", *Langmuir*, vol. 16, pp. 8672-8676, June 2000.
- [18] F. Fabregat-Santiago, G. Garcia-Belmonte, I. Mora-Seró, J. Bisquert, "Characterization of nanostructured hybrid and organic solar cells by impedance spectroscopy", *Phys. Chem. Chem. Phys.*, vol. 13, pp. 9083-9118, March 2011.
- [19] Q. Wang, J.-E. Moser, M. Grätzel, "Electrochemical Impedance Spectroscopic Analysis of Dye-Sensitized Solar Cells", *J. Phys. Chem. B*, vol. 109, pp. 14945-14953, July 2005.
- [20] E. Barsoukov, J. R. Macdonald, "Impedance Spectroscopy Theory, Experiment, and Applications", Wiley- Interscience, pp.65, 79, April 2005.

Dimitra Sygkridou received her diploma in Electrical and Computer Engineering from the University of Patras, Greece in 2010 and her M.Sc in Environmental Sciences from same university in 2013. She is a PhD candidate at the Department of Physics, University of Patras since 2013. Dimitra Sygkridou has published her research in peer reviewed scientific journals and international conferences. Her field of research focuses on third generation photovoltaics, materials science and building integration of photovoltaics. She is also a member of the Technical Chamber of Greece since 2010.

Dimitrios Karageorgopoulos got his diploma in Physics followed by a Master's degree in Electronics and Computer Science at the University of Patras, Greece in 2010. As an undergraduate student, he worked on the development of a computer based automatic method to measure the surface conductivity of semi-conductive samples, according to the Van Der Pauw technique of four-point probes. Currently he is a PhD student at the department of Physics, University of Patras. His specific research interest is focused on the third generation solar cells (based on dyes, perovskites, quantum dots).

Professor Elias Stathatos was born in 1968 in Patras, Greece. He obtained his first degree in Physics from University of Patras and then his Ph.D. degree from Engineering Science Department also in University of Patras. Prof. Stathatos was a postdoctoral research fellow in University of Cincinnati, USA at the Civil & Environmental Engineering Dept. Professor Stathatos is the head of the Nanotechnology and Advanced materials laboratory and he has more than 100 publications in peer review journals and five chapters in books which are recognized of more than 3500 citations (*h-factor*=30). He is an editorial board member for Journal of Advanced Oxidation Technologies, Materials science in semiconductor processing and international Journal of Photoenergy.

Professor Evangelos Vitoratos is currently member of condensed materials section in Physics department at the University of Patras. His research interests include Electronic Transport properties in solids (Conducting polymers -semiconductors) and Materials for Organic Electronics. He has more than 60 publications in peer review journals which are recognized of more than 700 citations (*h-factor*=13).