

Influence of Harmonics on Medium Voltage Distribution System: A Case Study for Residential Area

O. Arıkan, C. Kocatepe, G. Ucar, Y. Hacialiefendioglu

Abstract—In this paper, influence of harmonics on medium voltage distribution system of Bogazici Electricity Distribution Inc. (BEDAS) which takes place at Istanbul/Turkey is investigated. A ring network consisting of residential loads is taken into account for this study. Real system parameters and measurement results are used for simulations. Also, probable working conditions of the system are analyzed for 50%, 75%, and 100% loading of transformers with similar harmonic contents. Results of the study are exhibited the influence of nonlinear loads on %THD_v, P.F. and technical losses of the medium voltage distribution system.

Keywords—Distribution system, harmonic, technical losses, power factor (PF), total harmonic distortion (THD), residential load, medium voltage.

I. INTRODUCTION

THE efficiency of electric power distribution systems have more importance in last decades. Distribution companies are aimed to supply more reliable, sustainable and high quality electrical energy to their consumers.

Distribution losses and power quality are the most important problems of Electric Power Distribution Companies (EPDC). Many studies are presented in literature about power quality problems and distribution losses. Also, large projects are carried out especially at developing countries for reducing the distribution losses and to improve the power quality.

One of the main subjects of power quality is harmonic components of current and voltage waveforms [1]. Harmonics leads to the increase of power quality disturbances and losses in distribution systems.

Harmonic components at power systems have increased due to the increase of nonlinear loads. Particularly the loads which are used in residential areas have nonlinear characteristics [2]. Therefore; investigations of harmonic impact on distribution systems losses a great importance.

Electric power distribution system losses are classified into two groups: technical losses and non-technical losses [3], [4]. Technical losses occur due to energy transfer. The main sources of them can be described as line conductor losses and

transformer no-load and load losses. The general causes of non-technical losses are electricity theft, metering problems, problems of billing and collection, loose connections, etc. [3]-[5].

Technical experiences about the loss reduction projects carried out in Iran are given in [3]. Causes of losses and loss reduction methods are presented in this study. In another study which is realized for a Brazilian distribution company, distribution system is divided into eight segments and a methodology for calculating the technical losses is proposed [6]. A very useful study for distribution system loss minimization techniques is presented as a bibliographical survey in [7]. The accurate estimation of losses in distribution system is a significant subject for EPDC. An applicable approach for this purpose is given in [5].

Influence of harmonics on distribution system technical losses is a research area for engineers. Especially in distribution systems, because of the load characteristics, harmonics have an increasing effect on technical losses of the lines and transformers.

Investigations of Dalila M.S. et al shows that harmonics have a negative effect on the life of transformers and increase the loss of these devices [8]. Also, adverse impact of harmonics on faults, life, loss, power factor and efficiency of distribution network is known and a study about harmonic suppression is given in [9]. Another study is realized by M. T. Au and his friends to show the impact of loss reduction methods on harmonic performance of distribution system for medium voltage level, low voltage level and transformers [10]. A concept for optimal operation of distribution system including harmonics is proposed and implemented for 16-bus distribution system in [11].

In this study, influence of harmonics on medium voltage distribution system is analyzed. A ring network consisting of residential loads is taken into account and the operating voltage of the system is 34.5 kV. The simulations are realized by using CYME Power Engineering Software. Results of the study show that nonlinear loads have an undesired impact on the investigated area.

II. MATHEMATICAL BACKGROUND

A. Power System Harmonics

Harmonics are defined as sinusoidal voltage and current waveforms at integer multiples of the fundamental power frequency [1]. Due to the harmonic component content,

O. Arıkan is with Electrical Engineering Department, Yıldız Technical University, Istanbul, Turkey (corresponding author to provide phone: +90-212-3835823; fax: +90-212-3835858, e-mail: oarikan@yildiz.edu.tr).

C. Kocatepe is with Electrical Engineering Department, Yıldız Technical University, Istanbul, Turkey (e-mail: kocatepe@yildiz.edu.tr).

G. Ucar and Y. Hacialiefendioglu are with Boğaziçi Electricity Distribution Inc, Istanbul, Turkey (e-mail: gulten.ucar@bedas.com.tr, yagmur.hacialiefendioglu@bedas.com.tr).

waveforms of current and voltage have become non-sinusoidal. So, power equations that are defined for sinusoidal steady state conditions have to be redefined.

The instantaneous voltage and current can be defined as [12]:

$$v(t) = V_0 + \sqrt{2} \cdot \left(V_1 \cdot \sin(n\omega_1 t + \theta_1) + \sum_{n=2}^{\infty} V_n \cdot \sin(n\omega_1 t + \theta_n) \right) \quad (1)$$

and

$$i(t) = I_0 + \sqrt{2} \cdot \left(I_1 \cdot \sin(n\omega_1 t + \delta_1) + \sum_{n=2}^{\infty} I_n \cdot \sin(n\omega_1 t + \delta_n) \right) \quad (2)$$

where, V_0 and I_0 are the DC component of waveforms, V_1 and I_1 are rms values of fundamental frequency, V_n and I_n are rms values of voltage and current for nth harmonic level, θ_n and δ_n are phase angles of voltage and current for nth harmonic component, $\omega_1 = 2\pi f_1$ is the angular frequency of the fundamental frequency f_1 and n is the harmonic order.

Also, total rms values of voltage and current are expressed as:

$$V = \sqrt{\sum_{n=1}^{\infty} V_n^2} \quad (3)$$

$$I = \sqrt{\sum_{n=1}^{\infty} I_n^2} \quad (4)$$

Percentage content of n order harmonic voltage and current are given as:

$$\%HD_V = \frac{V_n}{V_1} \times 100 \quad (5)$$

$$\%HD_I = \frac{I_n}{I_1} \times 100 \quad (6)$$

Total Harmonic Distortion (THD) is one of the most commonly used indexes in standards. %THD values of voltage and current are defined as:

$$\%THD_V = \frac{\sqrt{\sum_{n=2}^{\infty} V_n^2}}{V_1} \times 100 \quad (7)$$

$$\%THD_I = \frac{\sqrt{\sum_{n=2}^{\infty} I_n^2}}{I_1} \times 100 \quad (8)$$

B. Technical Losses

In this study technical losses of a medium voltage distribution system is analyzed. The main source of the losses in this system is line losses and transformer losses [8], [9].

Line losses can be described as:

$$P_{Line_Losses} = 3 \cdot I^2 \cdot R \quad (9)$$

in sinusoidal conditions. But, when the harmonic components considered, we can redefine this equation as:

$$P_{Line_Losses} = 3 \times (I_1^2 + I_n^2) \cdot R = P_{L_1} + P_{L_n} \quad (10)$$

where, P_{L_1} is the losses at fundamental frequency and P_{L_n} is the loss belongs to harmonic components.

Transformer losses are expressed as [8]:

$$P_{Transformer_Losses} = P_{NL} + P_{LL} \quad (11)$$

where, $P_{Transformer_Losses}$ is total transformer loss, P_{NL} is no-load losses of transformer and P_{LL} is load losses of transformer. This equation is given for sinusoidal conditions; we can redefine it for non-sinusoidal conditions as:

$$P_{Transformer_Losses} = P_{Transformer_Losses_1} + P_{Transformer_Losses_n} \quad (12)$$

where, $P_{Transformer_Losses_1}$ is the total transformer losses at fundamental frequency and $P_{Transformer_Losses_n}$ is the losses caused by harmonics.

III. SYSTEM DESCRIPTION

In this study, a part of medium voltage distribution system which takes place at BEDAS is investigated. Real system parameters and measurement results of a ring network consisting of residential loads are taken into account and single line diagram of the system is given in Fig. 1.

There are 8 buses, 5 transformer substation, 5 feeder and 3 type of underground cable system is placed at the investigated part of distribution system.

Characteristic parameters of transformers, lines and measured feeder loads are given in Tables I, II, and III respectively.

TABLE I
CHARACTERISTICS OF TRANSFORMERS

Transformer No	Nominal Power (kVA)	Voltage Level (kV)	No Load Losses (kW)
TR_1	1600	34.5/0.4	2.8
TR_2	1600	34.5/0.4	2.8
TR_3	1600	34.5/0.4	2.8
TR_4	1250	34.5/0.4	2.25
TR_5	1600	34.5/0.4	2.8

TABLE II
CHARACTERISTICS OF LINES

Cable Type	Ampacity (A)	R (Ω /km)	X (Ω /km)
3x(1x240 mm ²)	510	0.099	0.1277
3x150 mm ²	400	0.1658	0.2435
3x95 mm ²	335	0.2529	0.1484

Residential loads with same characteristics are connected to the feeders. It is assumed that loading of the lines are balanced

and harmonic distortion of all the feeders are same. Power factor of the loads are taken as 0,9.

Harmonic components of the system were determined by the measurements which are realized by power quality analyzers. The measured current harmonic components of Feeder 5 are given in Table IV.

Harmonic content of the loads are modeled by using current injection method in simulation study.

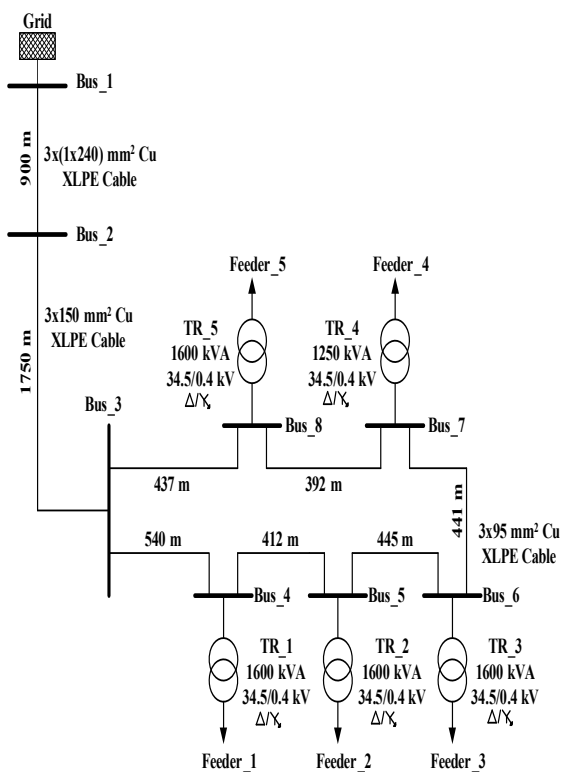

Fig. 1 Single line diagram of the system

TABLE III
LOADS OF FEEDERS

Feeder No	Load (kW)
Feeder 1	908
Feeder 2	853
Feeder 3	708
Feeder 4	518
Feeder 5	652

TABLE IV
HARMONIC COMPONENTS

Harmonic Order (n)	%HD _i	Harmonic Order (n)	%HD _i	Harmonic Order (n)	%HD _i
2	2.74	12	0.25	22	0.35
3	38.55	13	4.23	23	2.44
4	1.20	14	0.00	24	0.25
5	25.25	15	3.69	25	1.99
6	0.35	16	0.25	26	0.25
7	21.22	17	3.24	27	1.05
8	0.45	18	0.25	28	0.35
9	17.28	9	1.89	29	1.29
10	1.05	20	0.00	30	1.29
11	8.96	21	2.44	31	2.69
%THD_i		50.5			

IV. CASE STUDY

In this paper, technical losses, %THD_v values and power factor variations of the investigated system are analyzed for 4 different scenarios. Case studies are realized by using CYME Power Engineering Software. Cases which are taken into account in modeling are given below

Case 1: Real system parameters, loading conditions and measured values are considered.

Case 2: It is assumed that transformers loading rates are %50 of their nominal power.

Case 3: It is assumed that transformers loading rates are %75 of their nominal power.

Case 4: It is assumed that transformers loading rates are %100 of their nominal power.

Two diversified condition is carried out at simulations for all of the cases. In first one, harmonic components are ignored. This condition is shown by "A" at the tables of the simulation results. The second, harmonic components of the loads are considered according to the loading rates of the transformers. This condition is shown by "B" at the tables of the simulation results

A screenshot of CYME Power Engineering Software for the placement of the investigated distribution system is given in Fig. 2.

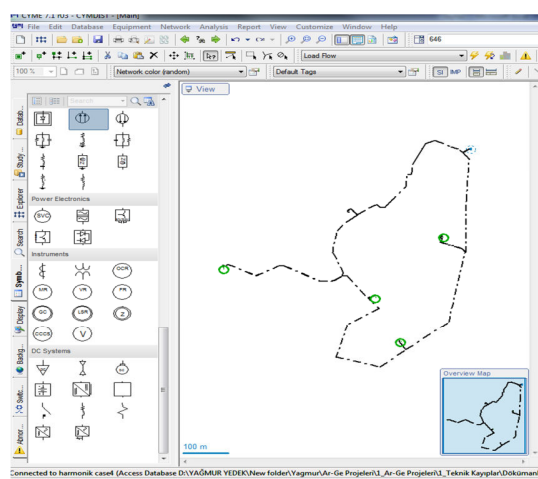

Fig. 2 Demonstration of the simulation program

The results of simulations show that harmonics which are caused by nonlinear loads, have an unfavorable influence on system behaviour. Total harmonic distortion levels of the buses are given in Table V for all the cases.

TABLE V
THD LEVELS OF THE BUSES

BUS NO	%THD _v			
	CASE 1	CASE 2	CASE 3	CASE 4
BUS 1	1.50	1.03	1.43	1.75
BUS 2	1.59	1.57	2.17	2.66
BUS 3	2.53	2.50	3.46	4.24
BUS 4	2.80	2.79	3.85	4.72
BUS 5	2.96	2.95	4.08	5.00
BUS 6	3.09	3.06	4.23	5.19
BUS 7	3.16	3.11	4.30	5.27
BUS 8	2.61	2.56	3.54	4.34

The outcomes of the study shows that %THD_v of the buses is decreasing when the bus is away from the nonlinear loads. Additionally, increasing loading rate of transformers has negative effect on distortion of bus voltages under nonlinear loading conditions.

Power factor variation of the considered system for different working conditions are given in Table VI.

It is clearly seen from the results that rise of loading rate and the presence of harmonics increases the loss of power transformers.

As presented about the transformers, harmonics have an influence on total distribution system losses. However, this impact is more adverse in low voltage systems; the performed study shows that a negative effect has seen at medium voltage distribution systems too.

According to the obtained results, harmonic components and increasing of loading are reducing the P.F.. Also, power factor of remote buses from the nonlinear loads are better than the neighbor ones.

TABLE VI
POWER FACTOR VALUES OF THE BUSES

BUS NO	POWER FACTOR (% P.F.)							
	CASE 1		CASE 2		CASE 3		CASE 4	
	A	B	A	B	A	B	A	B
BUS 1	92.01	91.98	92.33	92.30	90.61	90.59	89.40	89.38
BUS 2	91.19	91.16	91.47	91.44	90.02	90.00	88.95	88.93
BUS 3	90.66	90.63	90.92	90.88	89.67	89.65	88.71	88.70
BUS 4	90.43	90.40	90.54	90.51	89.41	89.39	88.51	88.50
BUS 5	90.36	90.33	90.58	90.55	89.44	89.42	88.54	88.52
BUS 6	89.99	89.96	90.61	90.57	89.46	89.43	88.55	88.53
BUS 7	89.51	89.48	90.73	90.69	89.54	89.51	88.61	88.59
BUS 8	88.64	88.62	88.96	88.94	88.35	88.33	87.72	87.70

In this study, impact of nonlinear loads on power losses is examined. The acquired results for transformer losses and total losses of investigated distribution system are shown in Tables VII and VIII respectively.

TABLE VII
TOTAL TRANSFORMER LOSSES

CASE NO		TRANSFORMER LOSSES (kW)				
		TR_1	TR_2	TR_3	TR_4	TR_5
CASE 1	A	6.40	5.05	7.06	10.19	9.90
	B	7.30	5.75	8.39	12.69	12.11
CASE 2	A	7.21	7.21	7.21	5.62	7.21
	B	7.48	8.61	8.61	6.69	8.60
CASE 3	A	12.96	12.97	12.97	10.03	12.96
	B	13.58	16.22	16.22	12.52	16.20
CASE 4	A	21.31	21.33	21.34	16.43	21.29
	B	22.45	27.33	27.34	21.05	27.27

TABLE VIII
DISTRIBUTION SYSTEM LOSS

CONDITION NO	TOTAL LOSSES (kW)			
	CASE 1	CASE 2	CASE 3	CASE 4
A	45.87	40.92	76.91	129.19
B	54.07	46.97	90.70	152.93

V. CONCLUSION

In this study, impact of harmonics and loading rate on %THD_v, P.F. and technical losses of medium voltage distribution system are investigated. The operating voltage of the system is 34.5 kV. CYME Power Engineering Software is used to realize the simulations.

Four different scenarios are used to analyze the effects of nonlinear loads on investigated system. The obtained results show that:

- %THD_v value of the busses are increasing according to the rising of the loading rate,
- %THD_v of the buses are decreasing when the bus is away from the nonlinear loads,
- The harmonic components and increase of loading rate are reducing the P.F.,
- The transformer losses and total system losses are increasing due to the loading rate and harmonic component content.

ACKNOWLEDGMENT

Authors would like to thank the Energy Market Regulatory Authority (EPDK) for full financial support of the project namely "Methodology and Software Development For Determining The Most Real-like Technical Lost Levels Dynamically in Distribution Networks", Project No: BDS.07.14.001. Also thanks to BEDAS R&D Department for the collaboration with Yildiz Technical University academician team.

REFERENCES

- [1] J. Arrillaga and N. R. Watson, *Power System Harmonics, 2nd Edition*, Wiley, 2003.
- [2] R. Singh and A. Singh, "Energy Loss Due to Harmonics in Residential Campus – A Case Study", 45th International Universities Power Engineering Conference (UPEC), p. 1-6, 2010.
- [3] A. Arefi, J. Olamaei, A. Yavartalab and H. Keshtkar, "Loss reduction experiences in electric power distribution companies of Iran", *Energy Procedia*, p. 1392 – 1397, 2012.
- [4] R. Nidhirithikrai, K. Audomvongseree, B. Eua-arporn, "Loss Assessment in a Low-Voltage Distribution System", 6th International Conference on Electrical Engineering/Electronics, Computer, Telecommunications and Information Technology (ECTI-CON 2009), Volume: 01, p. 10-13, 2009.
- [5] C. A. Dortolina and R. Nadira, "The Loss That is Unknown is No Loss At All: A Top-Down/Bottom-Up Approach for Estimating Distribution Losses", *IEEE Transactions on Power Systems*, Vol. 20, No. 2, p. 1119-1125, May 2005.
- [6] C. C. B. Oliveira, N. Kagan, A. Meffe, S. Jonathan, S. Caparroz and J. L. Cavaretti, "A New Method For The Computation of Technical Losses in Electrical Power Distribution Systems", 16th International Conference and Exhibition on Electricity Distribution, CIRED 2001, Conference Publication No. 482, 18-21 June 2001.
- [7] S. Kalambe and G. Agnihotri, "Loss minimization techniques used in distribution network: bibliographical survey", *Renewable and Sustainable Energy Reviews*, p. 184–200, 2014.
- [8] Dalila M. S., Khalid M. N. and Md Shah M., "Distribution Transformer Losses Evaluation Under Non-Linear Load", *Australasian Universities Power Engineering Conference (AUPEC 2009)*, p. 1-6, 2009.
- [9] K. Deng, J. Cao, P. Guo and X. Xu, "Energy Saving Analysis of Harmonic Suppression in a Distribution Network", 2013 Fourth International Conference on Networking and Distributed Computing (ICNDC), p. 121-125, 2013.

- [10] M. T. Au, T. M. Anthony, Ma. Mohamad, "Strategies in Technical Loss Reduction and Its Impact on Harmonic Performance of Distribution Network", IEEE Bucharest Power Tech Conference, p. 1-6, 2009.
- [11] Z. Yong, L. Jianhua and X. Daozhi, "Distribution Network Optimal Operation for Loss Reduction and Harmonic Mitigation", International Conference on Power System Technology (PowerCon 2002), Vol. 4, p. 2522-2525, 2002.
- [12] C. Kocatepe, R. Yumurtaci, O. Arikan, M. Baysal, B.i Kekezoglu, A. Bozkurt and C. F. Kumru, "Power Quality Issues - Chapter 7: Harmonic Effects of Power System Loads: An Experimental Study", Intech, p. 175-200, 2013.

Oktay Arikan was born in Edirne, Turkey, in 1978. He is currently working as an Assistant Professor at the Electrical Engineering Department of Yildiz Technical University, Turkey.

His research interests include analysis of power systems, high voltage engineering and power quality.

Celal Kocatepe was born in Kastamonu, Turkey, in 1962. He is currently working as a Professor at the Electrical Engineering Department of Yildiz Technical University, Turkey.

His research interests include analysis of power systems, high voltage engineering and power quality.

Gulten Ucar was born in Samsun, Turkey, in 1989. She received the B.S. degree in electrical engineering from Yildiz Technical University, İstanbul, Turkey, in 2012. Currently she is working in the electrical distribution sector since 2012.

Her main fields of research are medium voltage, harmonics in power system, compensation on distribution network, technical loss reduction of electrical power distribution system, distributed generation, electric vehicles, energy storage

Yagmur Hacialiefendioglu was born in Rize, Turkey, in 1987. She received the B.S. degree in electrical engineering from Sakarya University, Sakarya, Turkey, in 2009. Currently she is working in the electrical distribution sector since 2011.

Her main fields of research are medium voltage, harmonics in power system, and compensation on distribution network, technical loss reduction of electrical power distribution system, overcurrent protection & coordination.