

# Evaluation Using a Bidirectional Microphone as a Pressure Pulse Wave Meter

S. Fujiwara, T. Kaburagi, K. Kobayashi, K. Watanabe, Y. Kurihara

**Abstract**—This paper describes a novel sensor device, a pressure pulse wave meter, which uses a bidirectional condenser microphone. The microphone work as a microphone as well as a sensor with high gain over a wide frequency range; they are also highly reliable and economic.

Currently aging is becoming a serious social issue in Japan causing increased medical expenses in the country. Hence, it is important for elderly citizens to check health condition at home, and to care the health conditions through daily monitoring. Given this circumstances, we developed a novel pressure pulse wave meter based on a bidirectional condenser microphone: this device is used as a measuring instrument of health conditions.

**Keywords**—Bidirectional microphone, pressure pulse wave meter, health condition.

## I. INTRODUCTION

THE world is becoming with aging or super aging society. Elderly people easily become diseases and many of them go to hospital. It leads to an increase in medical expenses, and may degree the quality of medical care as hospital staff members are overworked. Furthermore, increase in the medical expenses not only has influenced our cost of living, but has influenced the national budget of country. In order to solve this social issue, it seems important for elderly citizens to check their health conditions at home through daily monitoring. To deal with this issue, the conventional study links a sensor with information technology, namely mobile phone or network systems, thus a physiological monitoring system that always monitors daily life or sleep condition has been developed [1]-[5]. In this study, we develop a physiological monitoring system that utilizes the physiological information detected from outside the body. The system can detect heartbeat. In this paper, we propose a novel pressure pulse wave meter using on a bidirectional condenser microphone.

Microphones with an audio amplifier can detect changes in pressure with amplitude of  $2 \times 10^{-5}$  Pa in the frequency range of 20 Hz to 20 kHz, which corresponds to the frequency range that is sensitive of the human auditory system. They are pressure sensors with high sensitivity. Further, mass-produced

S. Fujiwara and K. Konayashi are with the Hosei University, 3-7-2 Kajinocho Koganei-shi, Tokyo 184-8584, Japan.

T. Kaburagi is with the Department of Industrial and System Engineering, College of Science and Technology, Aoyama Gakuin University, 5-10-1 Fuchinobe, Chuo-ku, Sagamihara-shi, Kanagawa 252-5258, Japan.

Y. Kurihara is with the Department of Industrial and System Engineering, College of Science and Technology, Aoyama Gakuin University, 5-10-1 Fuchinobe, Chuo-ku, Sagamihara-shi, Kanagawa 252-5258, Japan (corresponding author, Phone: +81-42-759-6371; e-mail:kurihara@ise.aoyama.ac.jp).

microphones are highly reliability and economical. It has been considered the microphone can detect pulse wave if the pulsatory motion can be detected on the surface of any part of the body. Furthermore as the device can measure pulse wave so long by being attached on the body, its user is relieved from the burden from a long-time pulse wave measurement.

## II. MATHEMATICAL MODEL OF A BIDIRECTIONAL ELECTRIC CONDENSER MICROPHONE

### A. Characteristics of Bidirectional Microphone

#### 1. Structure of a Bidirectional Microphone

Fig. 1 shows the structure of the bidirectional microphone. The structural feature of the microphone is that it has two pressure detecting ports: one is usually on the front side, and the other is on the rear side. The manner in which the pressure wave propagates to the microphone and the physical variables and constants associated with the phenomenon occurring in the microphone are described in (I) to (XI) in Fig. 1.

#### 2. Pressures at the Front Port and Rear Port

The source acoustic pressure  $p(t)$  can be described from description (I) in Fig. 1 as:

$$p(t) = P \sin\{2\pi f(t + \tau)\} \quad (1)$$

The audio wavelength is sufficiently long in comparison to the length of the microphone  $L$  in (II). Frequency  $f$  satisfies the following condition:

$$f \ll \frac{c_0}{L} \quad (2)$$

For example, suppose  $L = 5 \times 10^{-3}$  m, which is a standard length of microphones, the frequency is as follows:

$$f = \frac{340 \text{ m/s}}{5 \times 10^{-3} \text{ m}} = 68 \text{ kHz}$$

which is higher than the maximum audio frequency. For applications when the frequency is less than the maximum frequency such as 1 kHz or 100 Hz, Equation (2) can be satisfied. The time taken for sound to travel from the acoustic pressure source in (I) to the front port (III) is  $\tau$  and the time taken to travel to the rear port (VIII) must be  $\tau + \frac{L}{c_0}$  because the rear port is located  $L$  away from the front port, as shown in Fig. 1, and the pressures at the front port at the rear port can be described respectively as;

$$p_f(t) = P \sin\{2\pi f(t + \tau - \tau)\} = P \sin(2\pi f t) \quad (3)$$

$$p_r(t) = P \sin \left[ 2\pi f \left\{ t + \tau - \left( \tau + \frac{L}{C_o} \right) \right\} \right]$$

$$= P \sin \left\{ 2\pi f \left( t - \frac{L}{C_o} \right) \right\} \quad (4)$$

The pressure at the rear port can be written using the addition theorem of trigonometric functions as:

$$p_r(t) = P \cos \left( 2\pi f \frac{L}{C_o} \right) \cdot \sin(2\pi f t)$$

$$- P \sin \left( 2\pi f \frac{L}{C_o} \right) \cdot \cos(2\pi f t) \quad (5)$$

From (2),  $f \frac{L}{C_o} \ll 1$ , then  $2\pi f \frac{L}{C_o} \cong$ , and thus  $\cos \left( 2\pi f \frac{L}{C_o} \right) \cong 1$  and  $\sin \left\{ 2\pi f \frac{L}{C_o} \right\} \cong 2\pi f \frac{L}{C_o}$ .

Consequently, the pressure at the rear port can be described as:

$$p_r(t) = P \sin(2\pi f t) - P 2\pi f \frac{L}{C_o} \cos(2\pi f t) \quad (6)$$

The pressure at the front port  $p_f(t)$  and that at rear port  $p_r(t)$  act in a differential manner to the electret film (V), and the differential pressure can be obtained from (3) and (6) as:

$$\Delta p(t) = p_f(t) - p_r(t) = P 2\pi f \frac{L}{C_o} (2\pi f t)$$

$$= \frac{L}{C_o} \cdot \frac{dp_f(t)}{dt} = \frac{L}{C_o} \cdot \frac{dp(t-\tau)}{dt} \quad (7)$$

### 3. Dynamics of the Electret Film

The dynamics of the electret film modeled by a lumped mass can be described from the equation of motion for the electret film as:

$$m \frac{d^2 x(t)}{dt^2} + d \frac{dx(t)}{dt} + kx(t) = A \Delta p(t) \quad (8)$$

### 4. Output Voltage from Capacitor Owing to Displacement $x(t)$

From the physics of static electricity, the voltage between the electret film (V) and the electrode (VI) are given as a function of displacement  $x(t)$  in (8) as:

$$v(t) = -\frac{Q}{\epsilon A} x(t) \quad (9)$$

### 5. Electric Circuit

From the electric circuit of the capacitor to the input of the FET amplifier (IX), we have the following circuit equation:

$$ri(t) + \frac{1}{C} \int_0^t i(t) dt = v(t) \quad (10)$$

$$e'(t) = ri(t) \quad (11)$$

The output voltage is given by:

$$e(t) = -G e'(t) \quad (12)$$

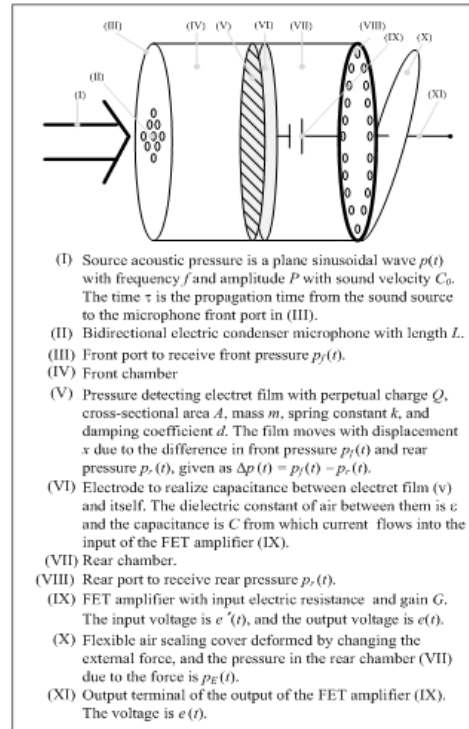

Fig. 1 Structure and elements of bidirectional microphone and associated variables and constant

Equations (7)–(12) lead to a transfer function of the output voltage  $e(t)$  with respect to the pressure  $p(t)$ , as shown in Fig. 2.

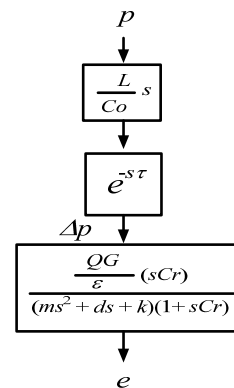

Fig. 2 Transfer function of output voltage  $e(t)$  with respect to source acoustic pressure  $p(t)$

The gain includes the temporal differential characteristic given by the differential element  $s \equiv \frac{d}{dt}$  and the gain  $\frac{L}{C_o}$ , which considerably reduces the gain in the low-frequency range.

### B. Characteristics of Microphone and Sensors

Consider the situation when the rear port is closed by cover (X) and the rear chamber (VII) in Fig. 1 is air sealed. The source acoustic pressure will be able to arrive at the front port but it will not be able to arrive at the rear chamber. When the flexible cover is pushed by an eternal vibratory force, the electret film is pushed to the front side by the pressure  $p_E(t)$ .

The electret film is pushed to front side by the pressure  $p_E(t)$ . Then, the transfer function for the abovementioned situation can be described as shown in Fig. 3.

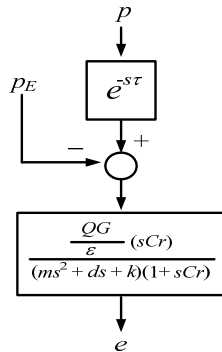

Fig. 3 Transfer function of output voltage  $e(t)$  with respect to source acoustic pressure  $p(t)$  and pressure  $p_E(t)$  caused by external vibratory force pushing flexible cover of rear port

Suppose,  $p_E(t) = 0$ , i.e., no external vibratory force is acting in Fig. 3, the bidirectional microphone acts as a high gain, low-frequency microphone with the gain  $\frac{L}{C_o}$ .

*C. Change in Characteristics of the Bidirectional Microphone by Switching the Cover of the Rear Port Open and Close*

As described in Sections A and B, the characteristics of the bidirectional microphone change simply change by opening or closing the rear cover. When the cover is open, the microphone acts as a bidirectional microphone, which is its original functionality; when the cover is closed, it becomes a low-frequency, high-gain microphone that detects pressure from the front port, as well as becomes a highly sensitive force vibration sensor that detects vibration through the flexible cover. Fig. 4 shows the frequency response for both cases derived by the transfer function in Figs. 2 and 3.

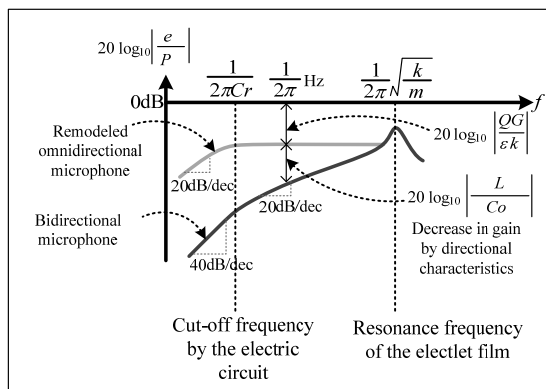

Fig. 4 Frequency response of the bidirectional microphone when the rear port is open or closed

From Fig. 4, the simple action of opening and closing of the cover (X) in Fig. 1 of the rear port considerably changes the microphone characteristics of frequency response. This simple action leads to a variety of novel and feasible application in the

health monitoring industry because such microphones are mass-produced and thus production lines are already developed for manufacturing. Hence, these microphones are highly reliable and economical.

III. EXPERIMENTAL VERIFICATIONS

A. Experiment Method

1. Fingertip Pressure Pulse Wave Meter

As an experimental model, we developed the fingertip pressure pulse wave meter that measures a fingertip put into the device. We focused on a fingertip because it is the part of the body where we can clearly measure the pulse wave. As the fingertip pulse wave meter typically exhibits photoelectric sphygmograph, we selected the fingertip as an appropriate part for the measurement. The mechanism of the fingertip pressure pulse wave measurement is as following: a rubber tube attached to the front of the microphone is put to a fingertip, covering the fingertip completely with the other end of the rubber tube sealed to be airtight. The reason for using the finger stall is that a finger stall is effective for catching a motion of the fingertip pulse. Fig. 5 shows the developed fingertip pressure pulse wave meter. The pressure in the pulse wave meter changes with motion of the pulse of a fingertip by sealing the fingertip like Fig. 5. It measures the pulse wave by detecting the pressure change in the bidirectional condenser microphone. The microphone uses the lower frequency wave amplifier, which combines an electric supply and the amplification. It corresponds to the lower frequency wave. For that reason, it is suited to the amplification of the lower frequency wave like the pulse wave. As for the measurement condition, the measurement is carried out by having a test subject sitting on a chair. The subject measures the pulse of the wrist while confirming its relation with the time by visual observation and feeling. If he comes to pulsate once per second, the measurement begins with the stable state of pulse. Measurement time is 10 seconds. As the measurement data is inserted as the output signal from the lower frequency wave amplifier, which performs the A/D conversion. This device can retain the output waveform and data. The fingertip pressure pulse wave meter, at the same time, carries out the measurement as photoelectric sphygmograph, like a general pulse wave meter. From the resulting data, we calculated the correlation coefficient, and examined the appropriateness of the fingertip pressure pulse wave meter. Earphone Type Pressure Pulse Wave Meter A microphone is used in an earphone and many people use an earphone for a long time. They are used in telephones, mobile phones, interphones, transceivers, computers, and various acoustic devices. We suggest a ubiquitous pulse wave meter, which enables the pulse wave measurement using an earphone. On that account, we developed earphone type pressure pulse wave meter.



Fig. 5 Fingertip pressure pulse wave meter

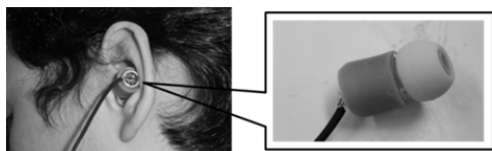

Fig. 6 Earphone type pressure pulse wave meter



Fig. 7 Systemic type pressure pulse wave meter

Fig. 6 shows the earphone type pressure pulse wave meter. A bidirectional condenser microphone is fitted inside one end of a rubber tube, and its other end is fixed to the pad of an earphone. A test subject puts on the earphone type pressure pulse wave meter without a break in the cavity of the ear. Therefore, the pressure in the ear is separated from the atmospheric pressure, and the device seizes the pulsatory motion inside the ear. The measurement mechanism is the same as that of the fingertip pressure pulse wave meter except the part to put in the fingertip. Systemic Type Pressure Pulse Wave Meter Utilizing the size of the device which facilitates the measurement of the pulse wave, we tried the measurement at other parts of the body in order to enable more proliferate application of the pressure pulse wave meter. Fig. 7 shows the systemic type pressure pulse wave meter. The bidirectional condenser microphone is fitted into one end of a rubber tube like the fingertip pressure pulse wave meter. Its other end is closed to be airtight, thus the pressure change in the rubber tube can be measured. By attaching the side of the rubber tube to a subject's body, the rubber tube warps with the pulse motion and pressure change is induced. The measurement was carried out with three body parts, the breast, the waist, and the leg. The photograph of the measurement with the breast shows the measurement over the clothes. This only shows the position of the measurement, and the actual measurement was carried out with the device attached directly to the body inside the clothes.

## A. Experimental Results

### 1. Fingertip Pressure Pulse Wave Meter

Fig. 8 shows the results from the measurement with the fingertip pressure pulse wave meter and the photoelectric pulse wave meter carried out at the same time.

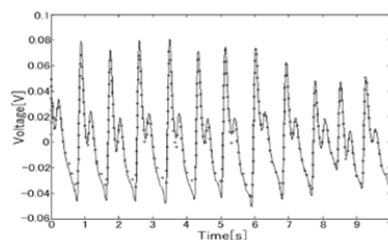

(a)

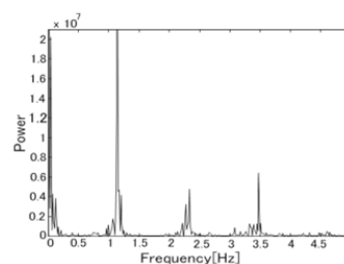

(b)

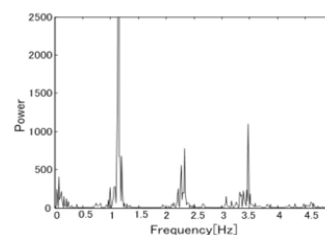

(c)

Fig. 8 (a) Waveform of pressure method (solid line), (b) Spectrum of pressure method, waveform of photoelectric method (broken line) (c) Spectrum of photoelectric method

Fig. 8 (a) shows the wave shapes of the fingertip pressure pulse wave meter and photoelectric pulse wave meter highly correspond with each other. The frequency is obtained from the undulated period. The interval between the peaks is 0.9s, and the frequency became about 1.1Hz in theoretical value. Figs. 8 (b) and (c) show the spectral graph, with the peaks around 1.1Hz, 2.2Hz, and 3.3Hz. The correlation coefficient between the fingertip pressure pulse wave meter and the photoelectric pulse wave meter was about 1.0.

### 2. Earphone Type Pressure Pulse Wave Meter

Fig. 9 shows the measured wave and the spectral graph obtained from the earphone type pressure pulse wave meter.

Fig. 9 (a) shows the peaks approximately with a 1.0s interval. Noise components were found at the parts other than the peaks. The spectral graph shows the frequency except for the 1 Hz, where the pulse wave could be confirmed.

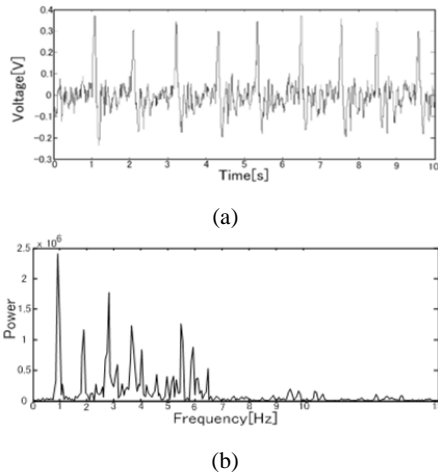

Fig. 9 (a) Waveform from the earphone type pressure pulse wave meter, (b) Spectrum

### 3. The Systemic Type Pressure Pulse Wave Meter

Fig. 10 shows the results from the measurements with the systemic type pressure pulse wave meter attached to three bed parts.

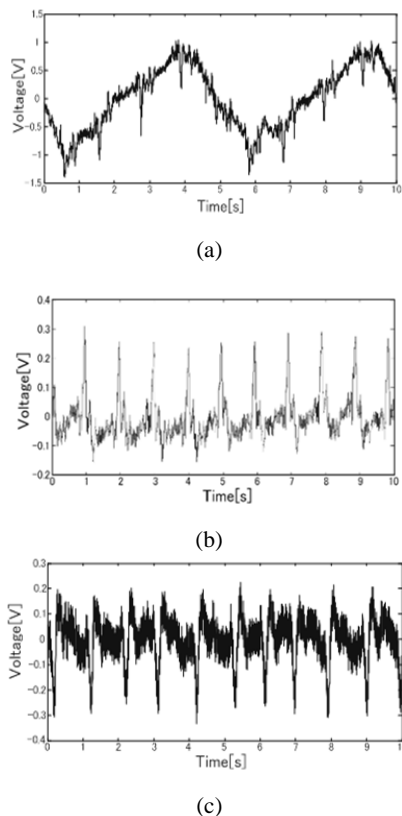

Fig. 10 (a) Waveform of the breast, (b) Waveform of the waist, (c) Waveform of the leg

These three graphs show the peaks detected mostly with a 1.0s intervals. With the measurements at the breast and the leg, the peaks which seem to be the pulse waves appeared in the minus direction. With the measurement at the waist, the peak appeared in the plus direction. The lower the measuring

position, the higher the noise effect is. Figs. 10 (a) and 11 show the noise components are lower than the pulse waves. In order to remove these low frequency noises, we used high-pass filter (HPF). Fig. 12 shows the result after the noise removal under 0.8Hz.

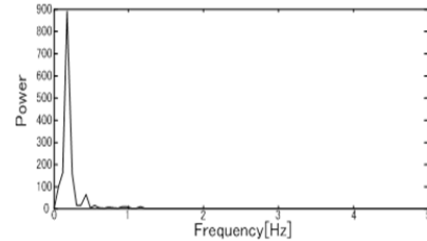

Fig. 11 Spectrum of a breast

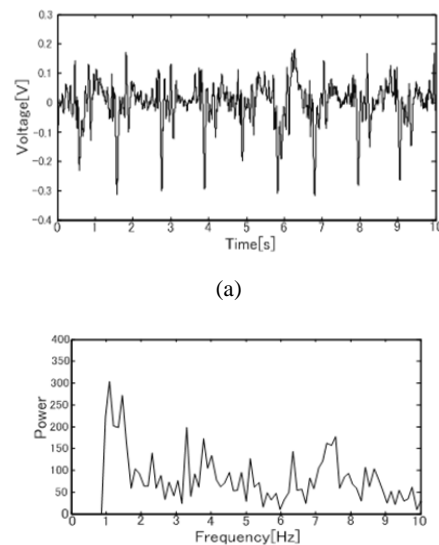

Fig. 12 (a) Waveform of a breast using high pass filter; (b) Spectrum

## VII. DISCUSSION

### A. Fingertip Pressure Pulse Wave Meter

Fig. 8 (a) shows the peaks with 0.9s intervals. This largely corresponds with the measurement of the pulse at the wrist. The peaks in the wave are considered to be the pulse motions. Figs. 8 (b) and (c) show three main peaks. The peak of the waveform at 1.1Hz is the same as theoretical value and its high frequencies are integral multiple. Compared with the two waves in (a), the shapes and the peaks showed larger correspondences, with the correlation coefficient was 1.0. The fingertip pressure pulse wave meter can detect the pulse wave with a closer accuracy to the photoelectric pulse wave meter.

### B. Earphone Type Pressure Pulse Wave Meter

Because the bidirectional condenser microphone, with its high sensitivity, detects small movements of face and head, the earphone type pressure pulse wave meter assumes much noise. The peaks appeared at about 1.0s intervals. The device seems capable of detecting pulse waves, and we considered a real-time measurement with the earphone type device by

separating from the components from the music frequency and that from the pulse wave.

### C. Systemic Type Pressure Pulse Wave Meter

The result from the measurement at the breast as shown in Fig. 10 (a) showed the wave had longer intervals than measurements at the waist and the leg. The wave form seems the respiration signals. The spectral graph in Fig. 11 emphasized the respiration signal without showing most of the pulse signals. So we used HPF to confirm the pulse signals as shown in the spectral graph in Fig. 12 (b). Furthermore this result could show the correspondence for both the pulse signal and the respiration signal by choosing the frequency. The result showed the measurement at the waist had much noise, but we consider the pulse signal still can be measured. The reason why the wave form for the waist is toward the plus direction is due to the difference of the applied pressure. The pulse signal could be detected at the leg, but much larger noise component appeared than the measurement at the waist. The noise effect increased as the measurement position is lowered. This is because the foot contacts the ground; the vibration is transmitted from the ground. The results of the study showed that the pulse signals can be detected from these three measurement points. In addition, the measurement at the breast enables the detection of the respiration signals.

## VIII. CONCLUSION

In this study, we developed novel method to measure the pulse wave using a bidirectional condenser microphone. The result of this study showed we successfully measured the pulse wave of low frequency, using the fingertip pressure pulse wave meter. In order to verify this measurement method, we compared its results with that obtained from a photoelectric pulse wave meter. The comparison resulted in the correlation coefficient of about 1.0, showing the pressure pulse wave meter could be a novel method. Hence, this verification was proven correct. We also verified the application of the method to other body parts. We developed an earphone type pressure pulse wave meter and a systemic type pressure pulse wave meter. The former can be applied to the ear, and the latter can applied to the breast, the waist or the leg. During the measurement, the respiration signals were also detected.

## REFERENCES

- [1] B. Sivertsen, et al.; "A Comparison of Actigraphy and Polysomnography in Older Adults Treated for Chronic Primary Insomnia," *SLEEP*, vol. 29, no. 10, pp.1353-1356, 2006
- [2] K. Watanabe, T. Watanabe, H. Watanabe, H. Ando, T. Ishikawa and K. Kobayashi, "Noninvasive measurement of heartbeat, respiration, snoring and body movement of a subject in bed via a pneumatic method," *IEEE Trans. Biomed. Eng.*, vol. 52, pp. 2100-2107, 2005
- [3] K. Watanabe, Y. Kurihara, and H. Tanaka, "Ubiquitous Health Monitoring at Home – Sensing of Human Biosignals on Flooring, on Tatami Mat, in the Bath tub, and in the Lavatory," *IEEE Sensors Journal*, vol. 9, no. 12, pp. 1847-1855, 2009
- [4] K. Watanabe, T. Watanabe, H. Watanabe, H. Ando, T. Ishikawa and K. Kobayashi, "Noninvasive measurement of heartbeat, respiration, snoring and body movement of a subject in bed via a pneumatic method," *IEEE Trans. Biomed. Eng.*, vol. 52, pp. 2100-2107, 2005

- [5] N. Bu, N. Ueno and O. Fukuda, "Monitoring of respiration and heartbeat during sleep using a flexible piezoelectric film sensor and empirical mode decomposition," *Proc. IEEE Eng. Med. Biol. Soc.*, pp. 1362-1366, 2007.

**Shunsuke Fujiwara** received the B.E. degree in applied informatics from Hosei University, Tokyo, Japan, in 2014. He is now attending graduate school at Hosei University. His current interest is sensing devices.

**Takashi Kaburagi** was born in 1980. He received his BSEE, ME, and Ph.D. degrees from Waseda University, Japan in 2003, 2005, and 2009, respectively. He is an Assistant Professor at the Department of Industrial and Systems Engineering, Aoyama Gakuin University. His current research interests are time-series data analysis, bioinformatics, and information efficient text input systems.

**Kazuyuki Kobayashi** received M.E. and Ph.D. degrees from Hosei University, Tokyo, Japan, in 1991 and 1994, respectively. After serving as a visiting researcher at Oakland University, USA, he became a lecture and then an associate professor at Hosei University; he has been an associate professor since 2007. From 2009 to the present, he has been a Professor at Hosei University. His research interests are control theory and automatic control.

**Kajiro Watanabe** received M.E. and Ph.D. degrees from the Tokyo Institute of Technology, in 1968 and 1971, respectively. From 1969 to 1971, he served as a Research Assistant at Faculty of Engineering Hosei University. From 1971, he served the Lecture; from 1974 to 1984, as an Assistant Professor; and from 1985 to present, as Professor. From 1980 to 1981, he was the Visiting Associate Professor at Oakland University, Rochester, MI; and from 1981 to 1982, as the Research Associate at the University of Texas, Austin. In the industrial field, he acts as an authorized C.E. He is Chief Researcher of several projects conducted by the Ministry of Economy, Trade, and Industry, Japan. His major interests include control and instruments and he is currently interested in bio-measurement, sports measurement, robotics, fault diagnosis, vehicle and environmental monitoring, and intelligent control. He holds 75 patents, has 15 publications in the control engineering field, and has been a part of more than 332 referenced journals and conference proceedings. Dr. Watanabe is a member of the Society of Instrument and Control Engineers.

**Yosuke Kurihara** received M.E. and Ph.D. degrees from Hosei University, Tokyo, in 2003 and 2009, respectively. He joined Hitachi Software Engineering Ltd. in 2003. From 2009 to 2013, he was an Assistant Professor at Seikei University. From 2013 to the present, he has been the Associate Professor at Aoyama Gakuin University. His research interests include system engineering, sensing methods, bio-sensing, and system information engineering. He is a member of the Japanese Society for Medical and Biological Engineering.