

Robotics and Embedded Systems Applied to the Buried Pipeline Inspection

Robson C. Santos, Julio C. P. Ribeiro, Iorran M. de Castro, Luan C. F. Rodrigues, Sandro R. L. Silva, Diego M. Quesada

Abstract—The work aims to develop a robot in the form of autonomous vehicle to detect, inspection and mapping of underground pipelines through the ATmega328 Arduino platform. Hardware prototyping is very similar to C / C ++ language that facilitates its use in robotics open source, resembles PLC used in large industrial processes. The robot will traverse the surface independently of direct human action, in order to automate the process of detecting buried pipes, guided by electromagnetic induction. The induction comes from coils that send the signal to the Arduino microcontroller contained in that will make the difference in intensity and the treatment of the information, and then this determines actions to electrical components such as relays and motors, allowing the prototype to move on the surface and getting the necessary information. This change of direction is performed by a stepper motor with a servo motor. The robot was developed by electrical and electronic assemblies that allowed test your application. The assembly is made up of metal detector coils, circuit boards and microprocessor, which interconnected circuits previously developed can determine, process control and mechanical actions for a robot (autonomous car) that will make the detection and mapping of buried pipelines plates. This type of prototype can prevent and identifies possible landslides and they can prevent the buried pipelines suffer an external pressure on the walls with the possibility of oil leakage and thus pollute the environment.

Keywords—Robotic, metal detector, embedded system, pipeline.

I. INTRODUCTION

THE oil industry in the world has a strong economic impact, and its actuation is not restricted to the exploration and production; much more essential that remove the hydrocarbon of reservoir is distribute it, and its distribution is usually made by ducts. Despite having a key role in logistics, employ pipelines require some care, so that do not will not compromising safety in general nor compromising the environment.

The pipelines are subjected to natural damages, of which anomalies originate, resulting in cracking, curvature, kneading and corrosion; damages these that can bring consequences

Robson C. Santos is with Fluminense Federal Institute, Macaé/RJ, Automation and Control Engineering164 km Amaral Peixoto Road, CO 27932-050 and with Estácio de Sá University, General Alfredo Bruno Gomes MartinsHighway, s/n -Braga - Cabo Frio / RJ - Brazil (phone/fax: 55-22-2796-5016; e-mail: rcunha@ifff.edu.br),

Julio C. P. Ribeiro, Iorran M. de Castro, Luan C. F. Rodrigues, Sandro R. L. Silva, Diego M. Quesada are with Estácio de Sá University, General Alfredo Bruno Gomes MartinsHighway, s/n -Braga - Cabo Frio / RJ-CO 28909-800Brazil (phone/fax: 55-22-2646-2100, 55-22-2646-2100, 55-22-2646-2100, 55-22-2646-2100; e-mail: julio.pereira@estacio.br, iorranpt@gmail.com, luancarlos@yahoo.com.br, sandrostange@bol.com.br, diego.quesada@estacio.br).

such as interruption, accident risks, environmental problems and legal proceedings, beyond not be favorable to the company's image in society and regulators. Companies operating pipelines carry out inspections of prevention to prevent the occurrence of such problems.

Other factors should also be observed when a pipeline is buried, the conditions of deviations and ground efforts cannot be neglected, can inevitably result in an accident.

The inspection carried out in the pipelines is very important in reducing accidents that cause big environmental impacts, and in the observation of irregularities along the strip that may cause mechanical stress on the pipeline or endanger the existing installation.

A large part of the technologies used in the inspection of pipelines on the market aims to detect flaws in the finished, generally based on the changes of tension and currents to the coating protection [1], [2]. The proposed prototype will make inspections, not for failures caused by corrosion, but to detect some kind of tension, which the pipeline is submitted, as a consequence of a landslide from unstable areas.

The project is intended to create an autonomous vehicle to detect, inspect and map coordinate of underground pipelines and contribute to the credibility of the data obtained in the inspections, streamline the whole process. The system in question operates in the inspection of these buried pipes through an autonomous vehicle equipped with sensors and metal detectors, inductive coils, Arduino platform implemented in own programming language is much like the C / C ++ languages, readers and writers SD Card, GPS modules (global positioning system), motors and batteries. This vehicle interacts with a system implemented in PHP language, where the collected data is stored and worked for to calculate possible deviations and monitor various inspections conducted on different dates.

II. GENERAL CONTEXT OF PROBLEMS IN BURIED PIPELINES

The depth of these products is up to two meters underground and link maritime terminals and river terminals, refineries, piers, oil, and gas production fields, distribution companies and consumers. Thus, the route of this product line can cross a wide variety of places, such as rural and urban areas, roads and avenues, condos, hills and mountains, mangroves and forests, rivers and valleys. These places are built and operated within safety standards but are subject to erosion, landslides, corrosion, falling rocks, acts of vandalism; which can cause damage and possible leaks. Typically operating at high-pressure pumping and with highly dangerous

substances, so when there are cases of leaks, environmental and socioeconomic damage is extremely significant. A zero-failure condition for scratches or defects and possible abnormalities is impossible.

There are three families of possible defects:

- 1) Volumetric Defects: loss of metallic material, such as internal and external corrosion, groove and gauge.



Fig. 1 Internal corrosion

- 2) Geometrical defects: on the change of form, as kneading/dent, roundness, wrinkle and local buckle.



Fig. 2 Wrinkle

- 3) Planar defects: cracks, double lamination, misalignment of welds etc.



Fig. 3 Crack

Among the various faults the main ones are:

- 1) Material failure;

- 2) Operating failure;
- 3) Project error;
- 4) Defective construction;
- 5) Failure from the actions of third parties;
- 6) Soil movement.

These inspections are a set of actions to assess the conditions of structural integrity, corrosive processes, and mechanical damage among others. The pipeline operator must develop and implement Periodic Inspection plan, in order to maintain the structural integrity and safe operating condition of facilities, safety, environmental protection and compliance with legal requirements.

III. PROBLEM MOTION SOIL

To start understanding the problems caused by movement of the soil, or land on a buried pipeline; it is necessary to understand some of the forces to which the product is submitted. The causes of soil movement are of natural origin because the relief tends to reach an equilibrium position forces or base level. Therefore, slopes can trigger mechanisms resulting from atypical rains or even human interventions. So this mechanical behavior is influenced by some forces that result or assist in soil movement.

This paper discusses only the soil movements, land flow and slip, being these the most significant causes of stress or strain in rows ducts.

A. Land Flow

The land flows correspond to deformation, or continuous movements, taking or not defined movement surface. In terms of movements receive two types of classification: run is the flow fluid-viscous and crawling is flow plastic [3].

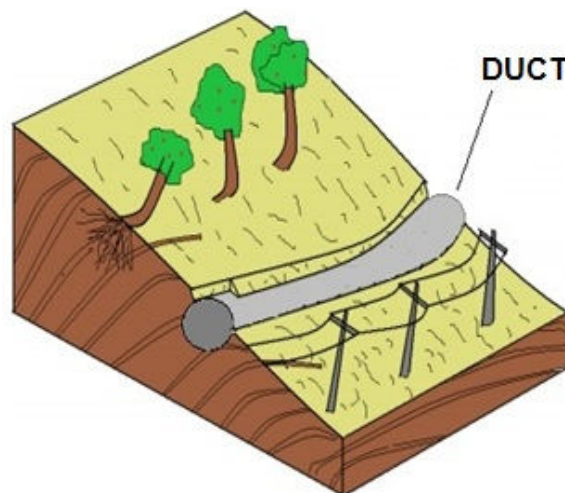

Fig. 4 Land flow

When the movement of the slope material is slow and the continuous way that is difficult to differentiate the moving part of the part at rest, called the crawl. In this case, the mass is moved by gravity via present factors such as temperature and humidity. Its speed can be on the order of millimeters per year, and it may be a slope of a whole region.

When the movement of the slope is faster and purely hydrodynamic by excess water can be defined as running.

B. Land Slip

Land slips are quick movements of soil and stones, the speed can reach some meters per second, occur by the nature of the terrain and surface slope, and downward and out the slope or hillside and is the result of the severity of the action [3].

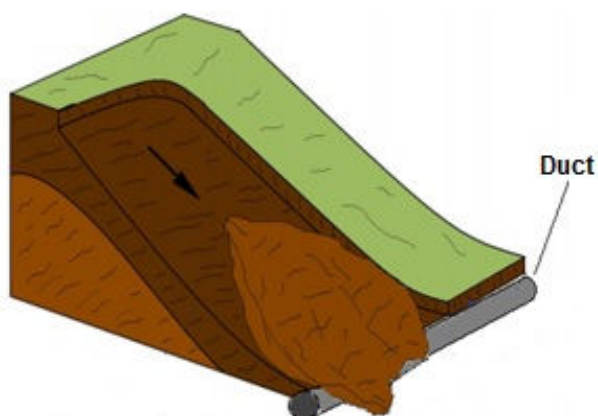

Fig. 5 Land Slip

The orientation of pipelines buried in soil mass, subject to movements, can be simplified as shown in Fig. 6, but may not represent the actual conditions found on site [3]. This is just a simplified guidance, in practice the movement can occur at an angle in relation to the pipeline, as well as also is common the lines presenting curved sections along its length.

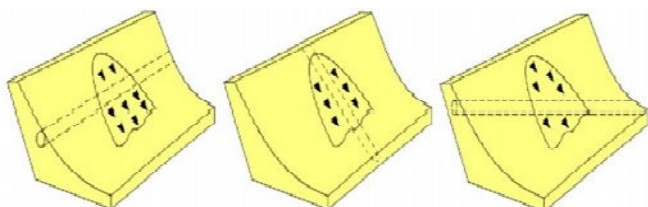

Fig. 6 The orientation of pipelines buried

The ducts are in need of structural design, but are not limited to just this, since there is necessity of considering geotechnical features in their design. Therefore, the soil that surrounds it is responsible for transmitting of efforts and is extremely relevant to consider the mechanical soil-duct.

Reference [4], "the duct line always will seek the configuration of least resistance to impose the movement against the ground. In half-buried ducts and less resistant soils, the displacement tends to the side with the weight of duct offering greater resistance to lifting. For buried pipes at greater depths and in more resistant soils, the shifting trend is vertical. In this case, the duct finds greater lateral soil resistance and consequently more difficult to break the soil sideways. From these considerations, it is concluded that the soil strength and the depth of burial of the pipeline are keys to the analysis of soil-pipe interaction".

The mechanical behavior of buried pipelines is one of the main factors to be considered the soil arching, that is, when a trench is excavated creating a cot, and it is placed any structure, Fig. 7. After in this the structure is buried in trench, and thus has a redistribution of the stresses arising at the site of interaction between the soil and the structure, altering the original system. So considering this structure a duct, the soil arching is the redirection of forces acting in this duct (own weight of the landfill and overloads) from the redistribution of stresses caused by the movement of masses of soil [5]. In this way can generate a load increase or reduction in the pipeline.

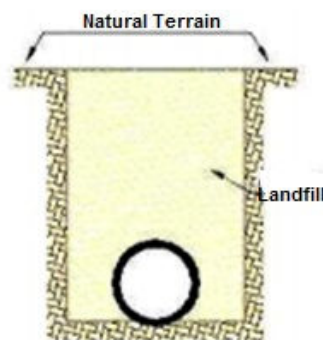

Fig. 7 Arching the soil

When the duct has the compacted soil in your top or the side, Fig. 8, a load is imposed; and if the material's resistance of duct to this load is exceeded, the wall of the duct suffers fissure or the cross section of the duct deform permanently.

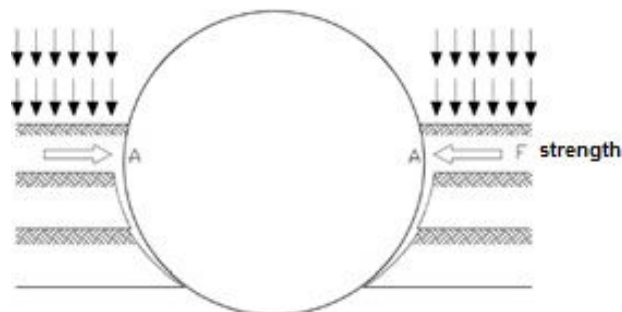

Fig. 8 Lateral strength applied to the duct

Reference [6], "for many of the buried pipeline deformation analysis, this deformation can be neglected but for others these should be considered, for it the collapse of duct can happen even if the tensions do not exceed their strength".

Land displacement, soil slip and thermal expansion also contribute to the emergence of forces acting on the duct, so that could cause damage to the pipeline or even a new mapping position of this duct is realized.

Reference [7] states:

"It should be noted on this inspection, along the entire length of the track, irregularities that may cause abnormal mechanical stress on pipes or jeopardize existing facilities, such as erosion, earth moving, collapsing, traffic of vehicle and/or heavy equipment on the track,

vegetation growth, track drainage system deficiency, fires, track invasion by third parties, realization of works near or that interfere with duct range (buildings and implosions), deficiency in its demarcation and signage warning, duct outcrop, crossing waterways with the apparent duct, subject to current water or with erosive processes that generate risk to the pipeline”.

IV. PROTOTYPE

Initially an electromagnetic signal is generated by the coil, when there is duct other electromagnetic field arises and disturbs the first, and then is perceived by the metal detector that sends a signal to the microcontroller (Arduino). The microcontroller is responsible for processing this signal and command the engines, Fig. 9 shows how a Project Overview.

The prototype is structured in two areas: the development of hardware (vehicle) and software development (system). The hardware is basically the construction of the vehicle with its electronic and mechanical devices; the software is to build the algorithm for the Arduino and implementing a PHP (Hypertext Preprocessor) for the treatment of the results.

A. Hardware/Metal Detector Module

The detector module comprises two electronic circuit boards previously elaborated to detect metal structures. Calls PI Polish Fig. 10, the plate generates an electromagnetic field that is disturbed by another magnetic field induced in the metal structures. So these disturbances will be received by the

Polish PI and in response sends a signal and analog electrical. This board is an electronic circuit composed of interconnections between capacitors, resistors, intergrades circuits, diodes and potentiometers arranged in this way has the ability to detect metals.

The device Pi Polish is responsible for detecting the duct. In this project, two of these boards are used, because each board triggers an induction coil that works as transmitter and receiver, Fig. 11.

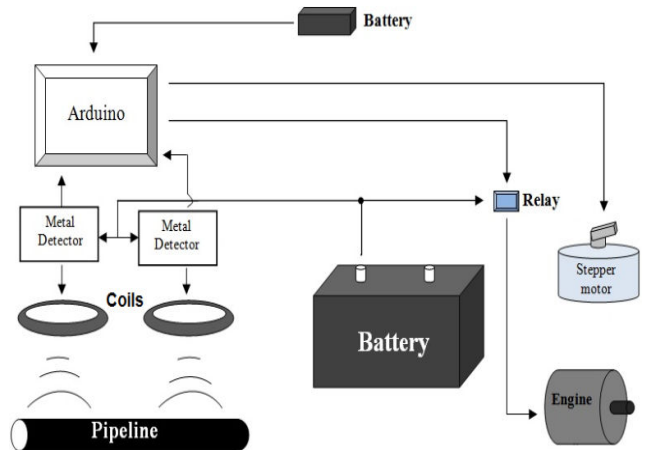

Fig. 9 Project Overview

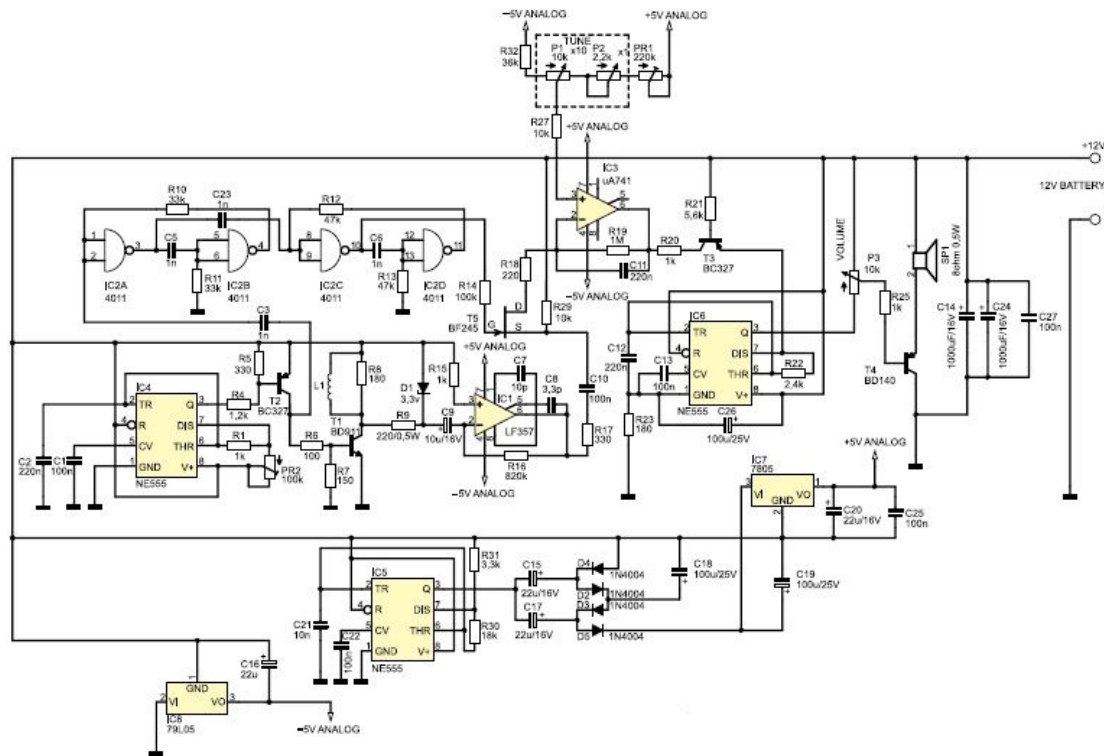

Fig. 10 Metal Detector

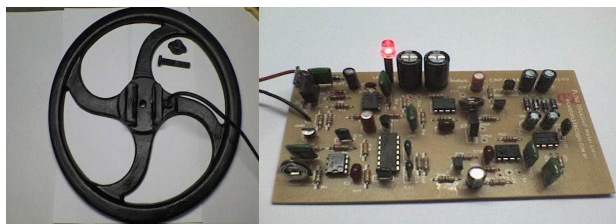

Fig. 11 Coil left and bord PI Polish right

B. Hardware/Arduino Module

Arduino is a flexible electronics prototyping platform open-source that uses the ATmega328 microcontroller. The Arduino can receive signals from several sensors and electronic handle this information to control motors, lights, servants and any other actuator [8]. The model used in the vehicle is the Arduino UNO Fig. 12.

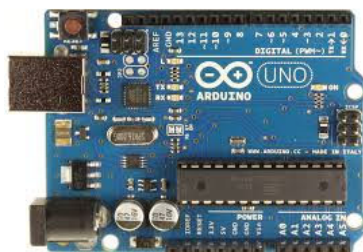

Fig. 12 Arduino UNO

The microcontroller used in the Arduino Uno is the ATmega328 from Atmel, which uses the Harvard architecture and is 8-bit, RISC, with 32KB of flash memory, 1KB of EEPROM, 2KB of SRAM, 32 general-purpose registers, 3 timers / counters , one USART, SPI communication ports, six AD7 converters of 10bits and watchdog timer, among other features [9]. His operating voltage is between 1.8 and 5.5 V. The Arduino is the brain of the prototype.

C. Hardware/Transmission Module

The transmission module has the function of mechanically driving the prototype, is composed of a relay, a DC motor, and a servo motor.

The DC motor is propellant and responsible for converting energy received by a battery in moving, driving the prototype forward as command Arduino. The relay has a switching function in an electronic circuit, in this prototype is used a unit whose function is to allow the arrival of electricity, battery coming to the engine Fig. 13, because this operate at a higher voltage and current that supported by Arduino.

The stepper motor, Fig. 14, has a closed circuit and operates proportionally to a command rather than spin freely without effective control of its position, the motor receives a control signal, it checks the current position and acts heading to the desired position.

With the algorithm developed is possible to control your turning, according to the predefined commands in the Arduino, so is this device that guides the prototype as seen in Fig. 15.

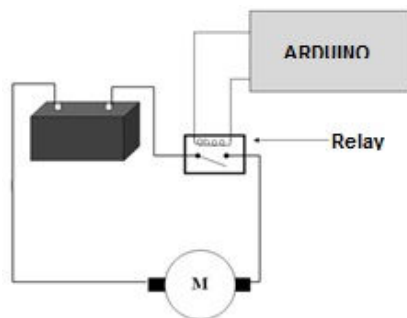

Fig. 13 Transmission Module



Fig. 14 Stepper motor

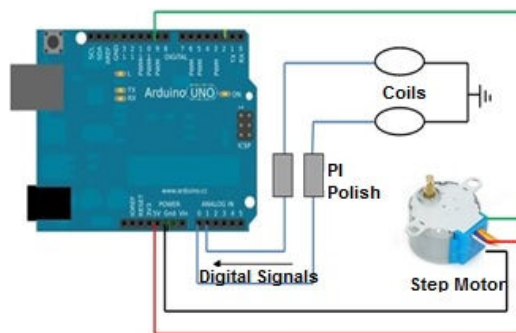

Fig. 15 Overview of Arduino/Coils/Stepper Motor

D. Hardware/GPS Module

The GPS receiver module, Fig. 16 is widely used. Typical applications are for use in navigation equipment. These modules feature small, easy application, low power consumption, high accuracy and a wide range of interfaces. The modules can be integrated antenna or interface for external antenna connection.



Fig. 16 GPS Receiver module

E. Hardwar/All Devices

An electric circuit diagram can be seen in Fig. 17, wherein this device by means of the two detector plates Polish PI (P1 and P2), a magnetic field is induced by coils (B1 and B2) in metallic structures. A other magnetic field arises in the presence of pipeline and will disturb the generated field. Thus, the Polish PI will perceive this disturbance and sending as response an analog electrical signal.

In Fig. 17 shows all physical devices, but only the relevant importance of devices have been described.

The Arduino (A) not does support receive this analogic sign. Therefore this sign passes before by current sensors (C1 and C2) to scale in the microcontroller parameters.

After receipt of the signals, the algorithm developed and stored in the EPROM (erasable programmable read only memory) of Arduino provides at the Stepper Motor (SM) the coordinate in degrees that the vehicle should be directed

(right, left or straight line). In the same time the Arduino sends a electric sign for relay module that automatically active the drive motor (DC), displacing the prototype.

For adapt the speed to the uneven ground the PWM circuit was inserted and finally the geographical coordinate the pipeline received in the GPS module (G), are stored on the SD card (SD) module.

F. Software/System

The Arduino IDE software used for microcontroller program includes a simple and intuitive graphical interface, and accepts code in C / C ++ but their language is their own. In order to develop a system able to present users with graphics possible deviations in the pipeline detected by autonomous vehicle a system was implemented in PHP (Hypertext Preprocessor) using the database management system MySQL which is a database management system and uses the SQL (Structured Query Language).

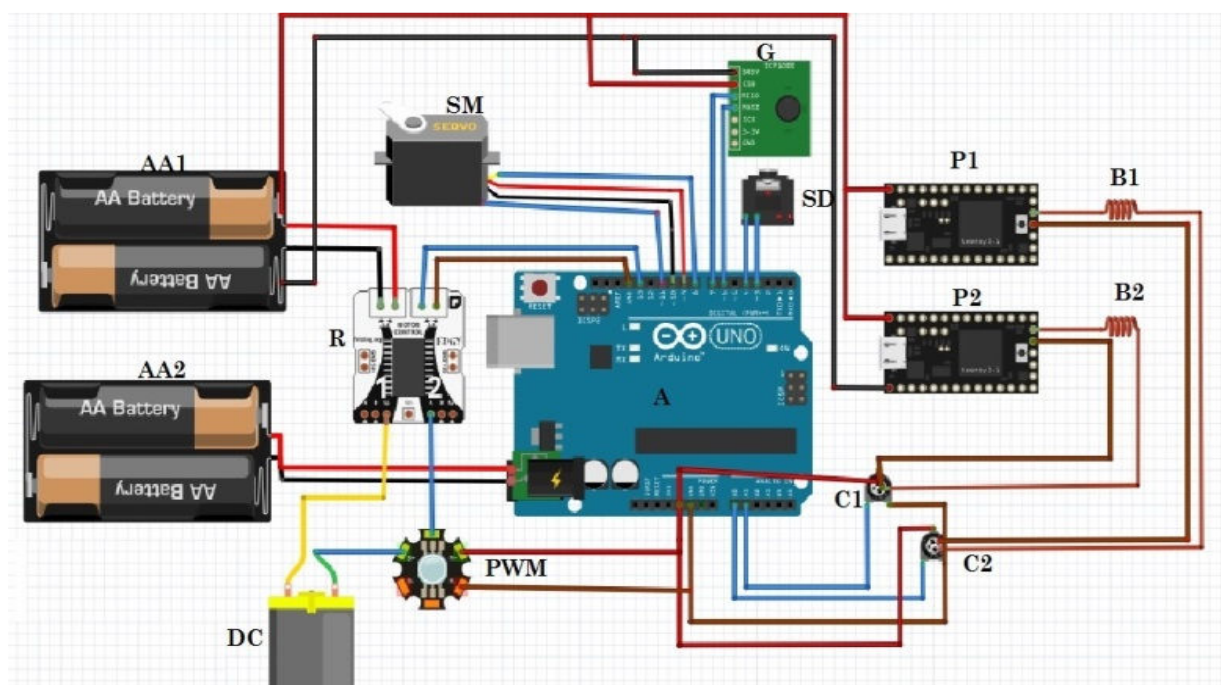

Fig. 17 Electric Circuit Diagram

The Pipeline Inspection System allows the user to import the analysis coming from the SD Card, previously captured by the autonomous vehicle and stores them in a database, and based on analyzes imported shows a graph with the initial coordinate and the coordinate analysis along with the date and time, allowing to check if the pipeline contains deviations, also indicating the coordinate of the exact location where there was deviation.

The system also allows to management the company's workflow, could quickly register the duct data and the work to be done, and subsequently hand over to the technician responsible for inspection. The Service Orders management selects the personnel involved in inspection that must be previously registered in the system at the following levels:

- 1) System (Manager): User with full access to the system, responsible for registering professionals and give rights to other users, and to open work order.
- 2) Coordinator: User with access to the system, responsible for the formation of the team, by the Annex of the analysis of Pipelines and the closing of the Service Order.
- 3) Operational: User who has access restricted to the system defined by different positions.

When creating a new order of service, the system informs the responsible engineer, the situation of the service order and their changes if the service process is modified, according to their situation:

- 4) Open: The user with level access to create an order of service, fills with the data and forwards it to the coordinator for the training of staff.
- 5) In Progress: the order of service is sent to the coordinator who will form the team and add analyzes of pipelines.
- 6) Closed: The Coordinator finalizes the order of service and supplies the data with the finished analysis to the results to be transformed into graphic data easy to understand.

To implement the system the following tools were used:

- 1) PHP (a recursive acronym for PHP: Hypertext Preprocessor) is a scripting language commonly used open source, widely used, and especially suited for web development and can be embedded into HTML [10].
- 2) APTANA STUDIO which is free open source software for IDE (Integrated Development Environment) developed in Java that supports PHP language.
- 3) MySQL is a database management system, which uses the SQL (Structured Query Language) as interface. It is currently one of the most popular databases, with more than 10 million installations worldwide [10].
- 4) ATASH is software for UML modeling. It is developed on the Java platform, which ensures its portability to any platform that has a Java virtual machine [11].
- 5) XAMPP is an independent server platform, free software, mainly consisting of MySQL database, Apache web server and interpreters for scripting languages: PHP and Perl. The name comes from the X abbreviation (for any of the different operating systems), Apache, MySQL, PHP, Perl. The program is released under the GNU license and acts as a free web server, easy to use and able to interpret dynamic pages.

V. MODELING LANGUAGE

The (Unified Modeling Language) UML language was used to model computer systems and help define the software features such as its requirements, its behavior, its logical structure, the dynamics of their processes and their physical needs for the equipment on which the system should be deployed [12]. All these features are defined by UML before the software start being really developed. UML is composed of different types of diagram, in this work was used the class diagrams for the design, use case, sequence and deployment, each representing the system under a given optics. The use of various diagrams allows faults are discovered, reducing the possibility of any future errors [13].

VI. STANDARD SOFTWARE ARCHITECTURE

Model-view-controller (MVC) is standard software architecture and works by separating the tasks of data access and business logic, presentation logic, and user interaction, by introducing a component between the two: the Controller.

The controller defines application behavior, interprets user actions and maps to Model calls. Based on user action and the outcome of Model processing, the controller selects a View to be displayed as part of the response to user request.

VII. SYSTEM OPERATION

The developed system initializes the process prompting the user when using the system; enter user login and password Fig. 18.

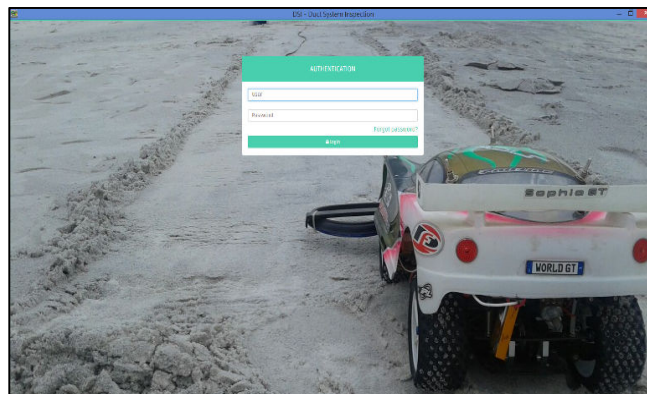

Fig. 18 User login screen

After login, the user is directed to the home screen that is the administrative panel, which contains all the options that can access according to their level of access.

When logged in, relevant information to the user are showed in the home screen, on the number of open service orders, ongoing and closed are displayed, as well as all service order information separated by each Coordinator. Thus, the professional of the system can easily see how many service order and what situations registered by the coordinators in the system.

The screen 'registering pipeline' Fig. 19, the user must first complete the upload of the file containing the information of original duct coordinate, putting the description, the length of the duct, the location (address), after checking the data, must click on the Register button and the duct will be registered and saved in the database. Once having completed the registration, the system will allow the user to import the analysis of the coordinate.

The link 'maintenance of pipelines', the system informs the description and address of registered ducts and also provides the option to edit duct data, manage coordinate, and graphics Fig. 20, and can also delete the duct.

The system also offers, using the Google Maps of the US Company Google, which is free on the web, to provide visualization of maps and satellite images of place for duct that is being inspected according to the coordinates captured by vehicle as shown in Fig. 21.

Under these conditions, the prototype will make the pipeline inspection and mapping and still provide data of deviations, besides favoring complete control of the services performed.

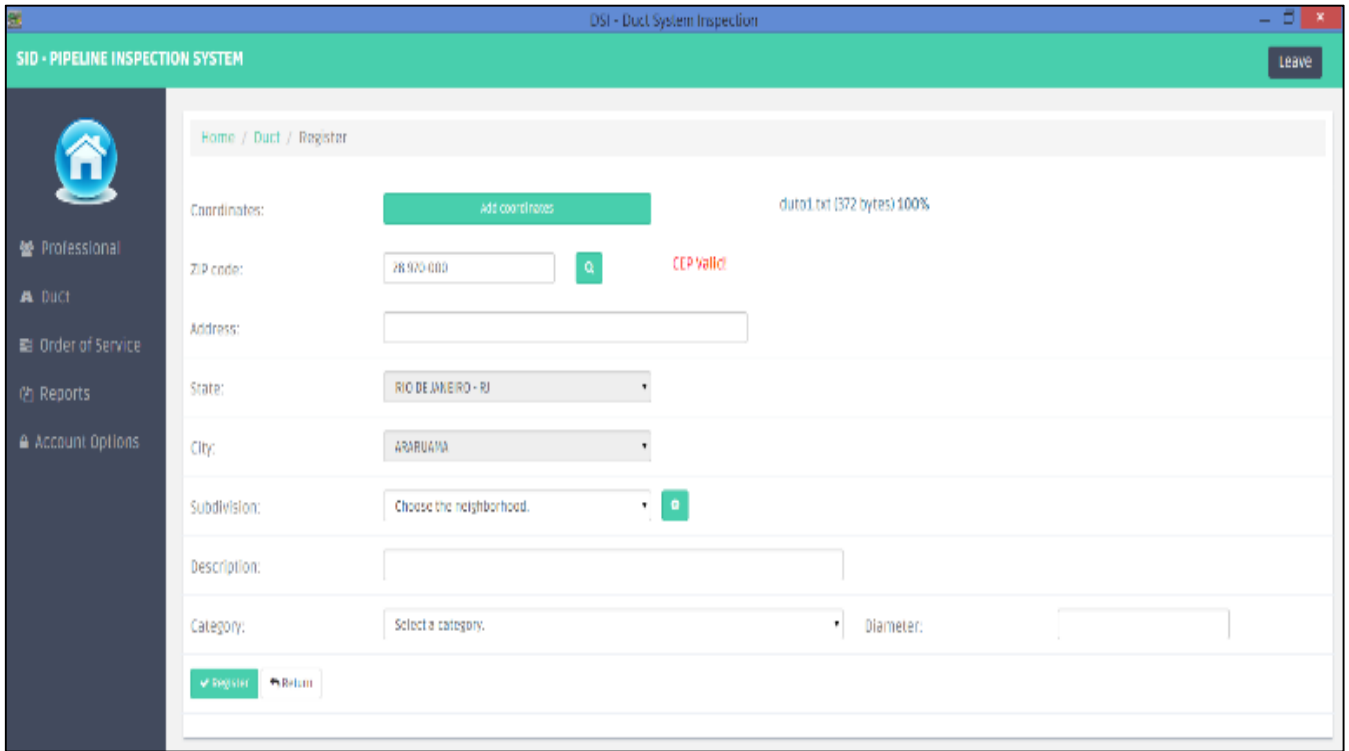

Fig. 19 Screen registering pipeline

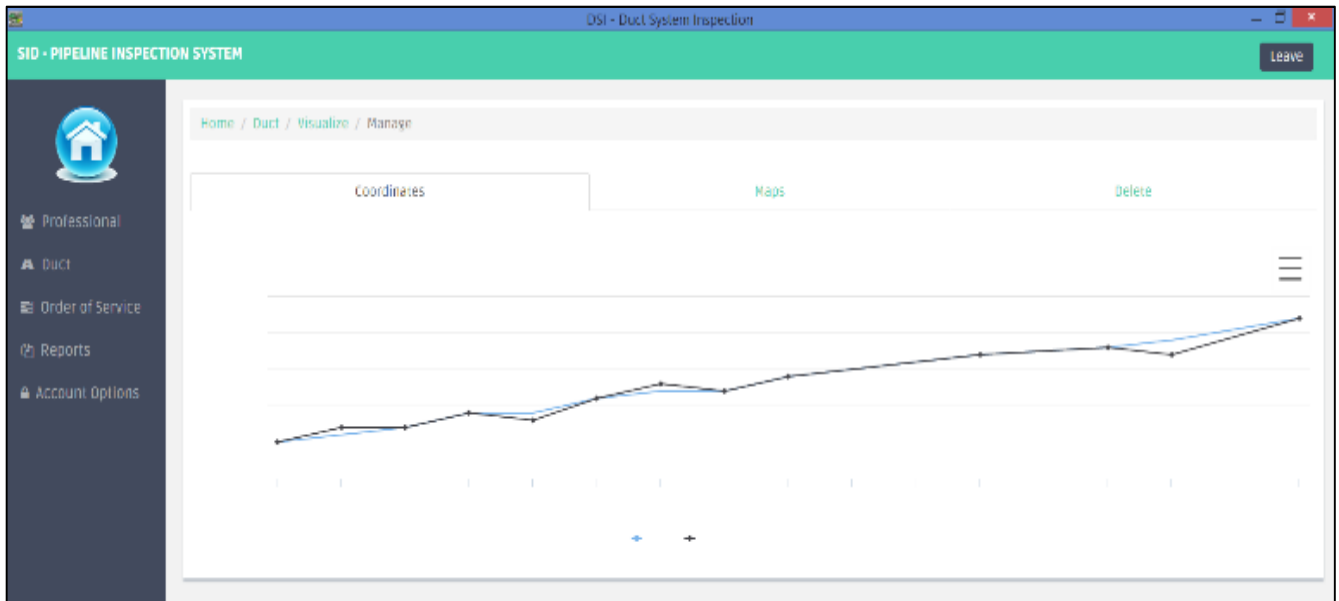

Fig. 20 Screen manage coordinate and graphics

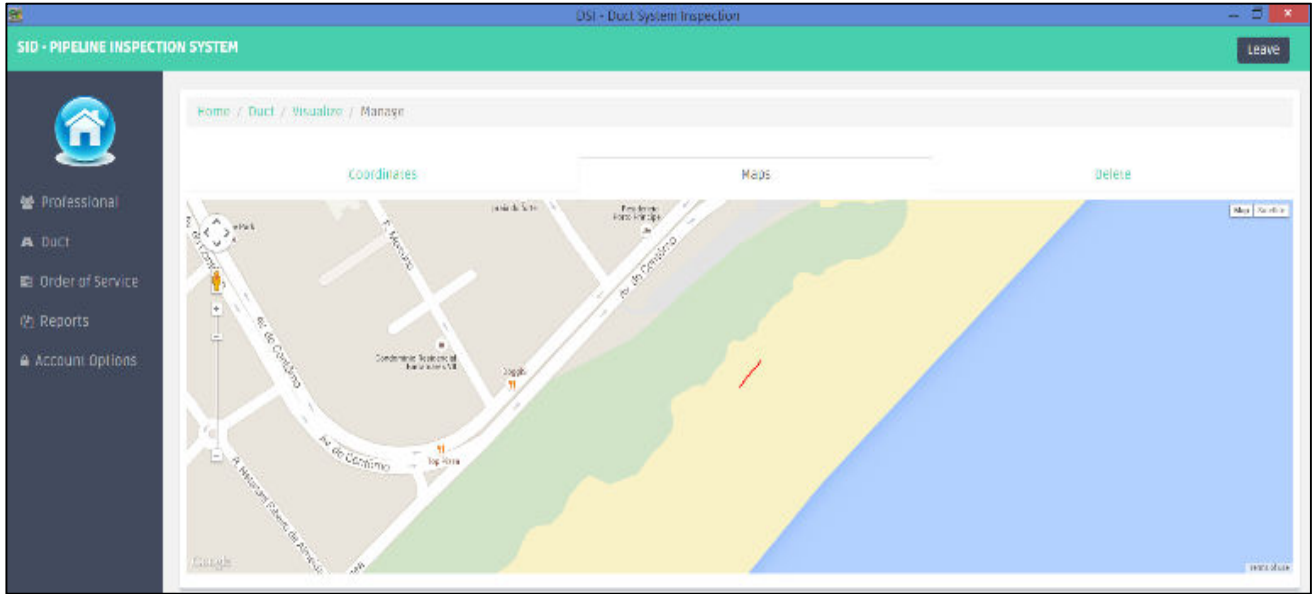

Fig. 21 Display of coordinates on the map

VIII. DIAGRAM PROTOTYPE/SYSTEM

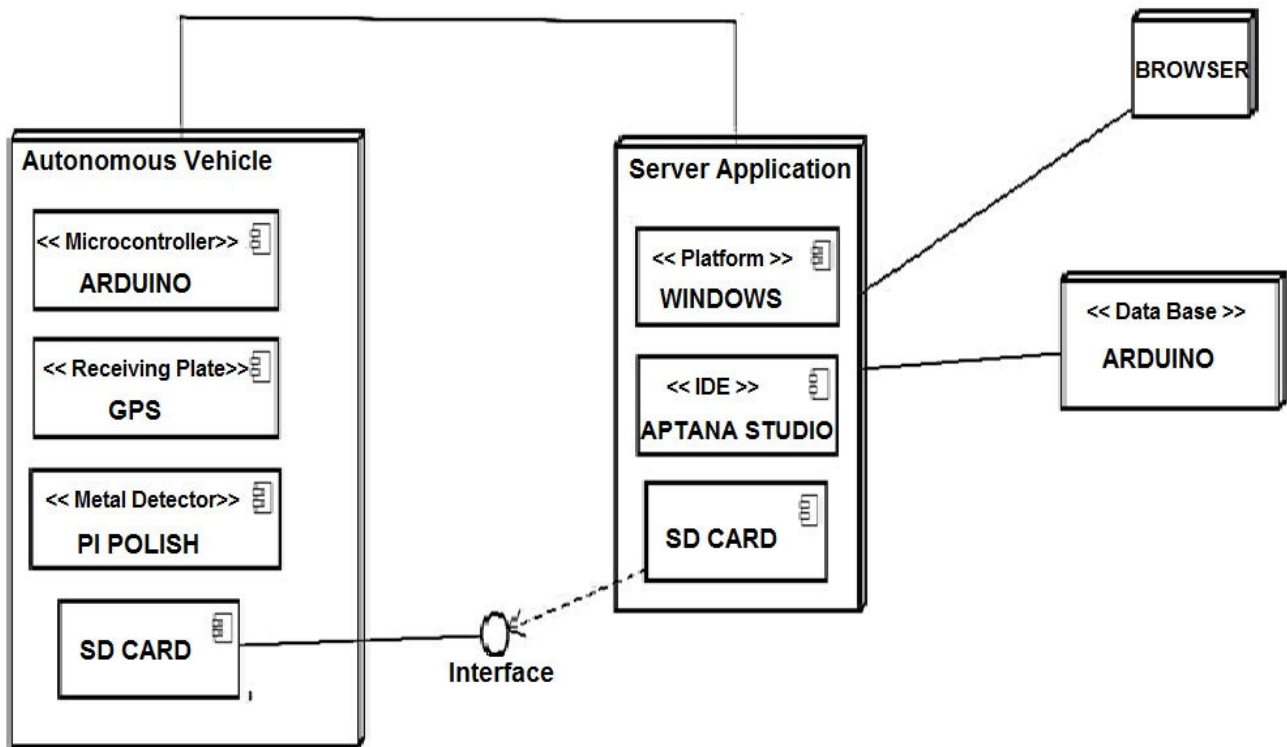

Fig. 22 Diagram Prototype/System

IX. RESULTS

A validation experimental was performed, a metallic duct of 2" diameter was buried in the soil to a depth of 10 cm. The initial coordinates were mapped and placed as input data of system, then the vehicle has been placed to detect and map the duct.

With these results, it is observed a correlation of geographical coordinates with the duct positioning processed in the prototype. The deviations observed were irrelevant in the order of 0.0001 Latitude; there was no deviation in Longitude (Table I).

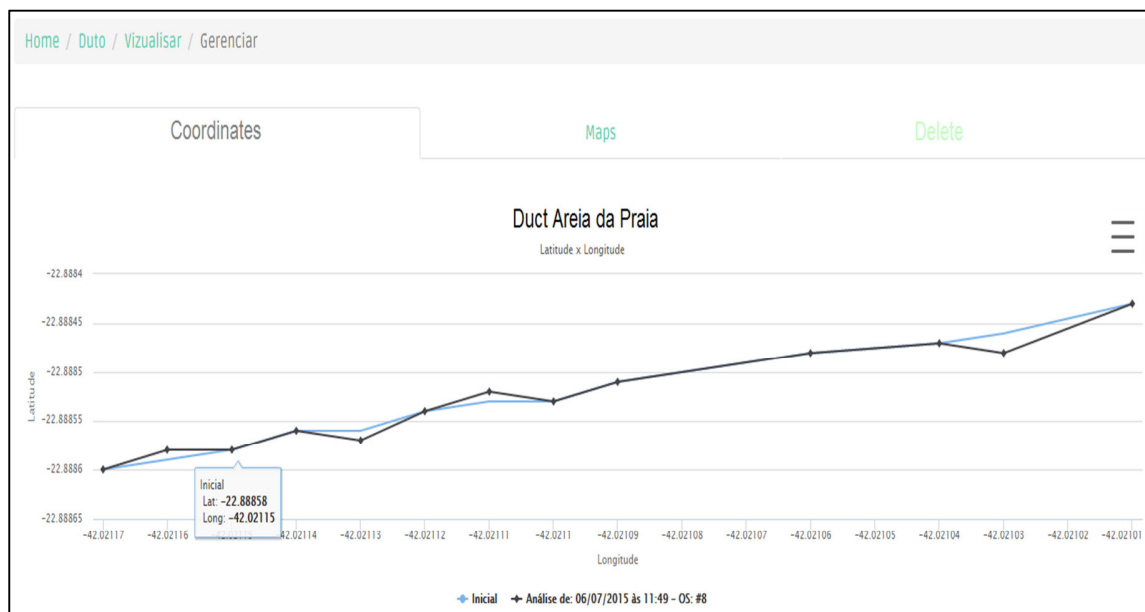

Fig. 23 Initial and mapped coordinate graph

TABLE I
COORDINATES DATA AND COORDINATES SYSTEM

Latitude First	Latitude System	Error (in Latitude)	Longitude
-22.88860	-22.88860	0.00000	-42.02117
-22.88859	-22.88858	0.00001	-42.02116
-22.88858	-22.88858	0.00000	-42.02115
-22.88856	-22.88856	0.00000	-42.02114
-22.88856	-22.88857	0.00001	-42.02113
-22.88854	-22.88854	0.00000	-42.02112
-22.88853	-22.88852	0.00001	-42.02111
-22.88853	-22.88853	0.00000	-42.02110
-22.88848	-22.88848	0.00000	-42.02106
-22.88847	-22.88847	0.00000	-42.02104
-22.88846	-22.88848	0.00002	-42.02103
-22.88843	-22.88843	0.00000	-42.02101

The graph of the input coordinates and mapping done by the vehicle can be seen in Fig. 22, and the map generated by the system in conjunction with Google Maps can be seen in Fig. 23. The observed red line on the map corresponds to the route made by the prototype where the pipeline was buried.

All detection trials were satisfactory, the GPS used in this autonomous vehicle corresponds to the used in prototyping, this presents a very weak satellite signal reception in areas with much interference, since it is an inexpensive GPS, however presented a accuracy, the test level and satisfactory so that the final test was performed by observing their use in the field, and as noted in the results were insignificant deviations. It is observed that as is prototype, a more precise and therefore more expensive GPS can be used to improve the accuracy of coordinates.

Immediately following is the prototype that functions autonomously inspecting ducts through electromagnetism and is getting the duct coordinates for possible comparisons with the original design. It is observed the electronics, auto chassis

model, the protective bodywork, coils and all electronic circuit boards. All these data can be seen in Fig. 24.



Fig. 24 Map generated in conjunction with Google Maps

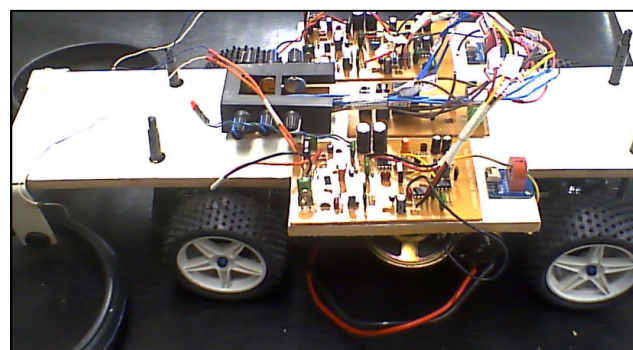

Fig. 25 Prototypes and their electronic equipment

In Fig. 25 it can be observed the mounting of the prototype with a standard model auto model



Fig. 26 Prototypes Complete

X.CONCLUSION

This paper presented a prototype of an autonomous vehicle showing the feasibility of automating the process and the external inspection services of buried pipelines, getting its detection and its mapping, improving working and contributing to the pipeline maintenance operators.

In conclusion that the system implemented for pipeline inspection enables the control of the information, it brings clarity to the manipulation and visualization of data from pipelines in addition to providing the user with a complete support tool and control of professionals, issuing service orders and the directing teams to perform.

The pipeline inspection system helps to identify deviations, and its great advantage is display the deviation of duct through charts. The system compares the initial coordinates and analysis enabling view the actual size of the deviation. Thus, it can be stated that the use of the prototype could avoid several environmental damages as well as the material losses for the company that carries your fluids through this pipeline will be minimized.

Using Google Maps search service for map display is another important point of the system, it allows the user to identify the exact location of the duct deviation.

Furthermore the prototype has the possibility to implement various other devices such as cameras; position sensors, motion, humidity, temperature; also can be added communication devices and controls from a distance, such as WiFi, Bluetooth, infrared and GPRS.

REFERENCES

- [1] R. F. V. Rios. "Detecção de Dutos Enterrados Empregando os Métodos GPR e Eletromagnético Indutivo". 2011. 90 f. Monografia (Graduação em Geofísica) – Instituto de Geociências, Universidade Federal da Bahia, Salvador, 2011.
- [2] C. A. Schimieguel; F. J. R. Castro; T. Pelliccioli. Estudo do Ambiente Periférico para Inspeção e Mapeamento de Dutos Metálicos Subterrâneos Utilizando o Método de Atenuação de Corrente. 2004. 120 f. Monografia (Graduação em Engenharia Elétrica Industrial) – Centro Federal de Educação Tecnológica do Paraná, Curitiba, 2004.
- [3] J. G. A. Pequeno. Comportamento de dutos enterrados sujeitos a movimentos de massa em solos. 2013. 140 f. Dissertação (Mestrado em Engenharia Civil) – Instituto Alberto Luiz Coimbra de Pós-Graduação e Pesquisa de Engenharia, Universidade Federal do Rio de Janeiro, Rio de Janeiro, 2013.
- [4] J. R. M. S. Oliveira. Modelagem em Centrifuga de um Problema de Interação Solo-Estrutura. 2005. 243 f. Tese (Doutorado em Engenharia Civil) – Universidade Federal do Rio de Janeiro, Rio de Janeiro, 2005.

- [5] A. M. Ferreira; D. M. S. Gerscovich; A. C. C. F. Siera. Estudo do comportamento mecânico de dutos enterrados. *In: Iberian Latin-American Congress on Computational Methods in Engineering*, n.27, 2007, Porto-Portugal. Anais... Porto: CILANCE, 2007. p. 1-13.
- [6] L.M. Teixeira. Análise numérica do comportamento de um oleoduto sujeito a movimentos de encosta. 2008. 123 f. Tese (Doutorado em Engenharia Civil) – Pontifícia Universidade Católica do Rio de Janeiro, Rio de Janeiro, 2008.
- [7] PETROBRAS. Norma-2098. Inspeção de Duto Terrestre em Operação. Rio de Janeiro, 1998.
- [8] M. Mcroberts. "Arduino Básico". 1º ed. São Paulo: Editora Novatec, 2011.
- [9] M. Banzi. "Primeiros passos com o Arduino". 1º ed. São Paulo: Editora Novatec, 2011.
- [10] F. Anselmo. "PHP e MySQL". Florianópolis: Visual Books, 2002. 4.
- [11] P.Deitel and H. Deitel. "Java: como programar" tradução Edson Furmankiewicz – 8ª. Edição – São Paulo - Pearson Prentice Hall, 2010.
- [12] G.T. A. Guedesanes. "UML - Uma Abordagem Prática". 1º ed.São Paulo: Editora Novatec, 2004.
- [13] C.Larman. "Utilizando UML e Padrões". 2º ed. Porto Alegre: Editora Bookman, 2003.