

Simulink Library for Reference Current Generation in Active DC Traction Substations

Mihaela Popescu, Alexandru Bitoleanu

Abstract—This paper is focused on the reference current calculation in the compensation mode of the active DC traction substations. The so-called p-q theory of the instantaneous reactive power is used as theoretical foundation. The compensation goal of total compensation is taken into consideration for the operation under both sinusoidal and nonsinusoidal voltage conditions, through the two objectives of unity power factor and perfect harmonic cancellation. Four blocks of reference current generation implement the conceived algorithms and they are included in a specific Simulink library, which is useful in a DSP dSPACE-based platform working under Matlab/Simulink. The simulation results validate the correctness of the implementation and fulfillment of the compensation tasks.

Keywords—Active power filter, DC traction, p-q theory, Simulink library.

I. INTRODUCTION

INCREASING the energy efficiency and improving the power quality in the traditional DC traction power systems is a present concern, as the presence of the uncontrolled rectifier substations leads to a significant harmonic distortion in the power supply, with dynamic behavior due to the random change in the traction load [1], [2]. By adoption the advanced solution of active power filtering, the adaptation to different load conditions and the flexibility in the compensation strategy are both allowed. In addition to the compensation capability, the IGBT-based voltage source inverter (VSI) in the APF's structure made it attractive in fulfilling the function of recovering the braking kinetic energy by direct return to the AC-power utility [3]-[5].

In [6], the concept of "Active Substation with direct return" is presented as an initiative of French National Railway Company to control the energy and to optimize the energy efficiency of railway transports system, by replacing the diode rectifier with a new converter (thyristor rectifier in antiparallel with IGBT-based APF).

The proposed system in Fig. 1 for regeneration and compensation keeps the structure of the DC traction substation and makes use of the APF's intrinsic capability to provide an imposed increased value of the DC-bus voltage. To ensure the regeneration function, the connection to the catenary line is made by a separating circuit (e.g. diode plus inductance, in the simpler variant), so that the current variation is handled and APF is decoupled from the DC-line when there is no recovery

Mihaela Popescu and Alexandru Bitoleanu are with the Faculty of Electrical Engineering, University of Craiova, 200440 Craiova Romania (phone: +40 251 435 255; fax: +40 251 435 255; e-mail: mpopescu@em.ucv.ro).

current.

As regards the coupling of VSI to the AC-line, it must be taken into account that the quality of the current injected into the AC-line depends of the difference between the voltage at the DC-side and the magnitude of the line-to-line voltage [7], [8]. Since there is a direct relationship between the rated DC-line voltage and the line-to-line voltage in the traction transformer secondary for each type of traction rectifier [9], [10], it results that there are practical situations in which APF cannot be connected in the secondary of the existing transformer. A dedicated transformer is required in these situations, as indicated by dashed line in Fig. 1. As an alternative, in order to use the existing traction transformer, the technical solution of a DC voltage elevation stage between the vehicle DC-line and APF has been presented in [11].

In regeneration mode, the prescribed current to be recovered is an active current in phase opposition with the transformer voltage at which APF is connected.

In active filtering mode, the DC-line is practically disconnected from APF and the control block prescribes a compensating current to APF in accordance with the adopted algorithm.

The attention in this paper is directed to the generation of the reference current for total compensation of both current harmonics and reactive power, based on concepts of the theory of instantaneous reactive power (so-called p-q theory). A dedicated Simulink library has been created, in order to be integrated on an experimental platform dSPACE DS1103, for operation under both sinusoidal and nonsinusoidal voltage conditions, taking into account both unity power factor (UPF) and perfect harmonic cancellation (PHC) compensation strategies.

The rest of this paper is organized as follows. Section II introduces the correlation between current and powers in accordance with the concepts of the p-q theory. Next, the methodology of reference current calculation is presented in four variants, two of them under sinusoidal voltage conditions and the other under nonsinusoidal voltage conditions. After presenting the Simulink library in Section IV, the simulation results in Section V validate the implementation of the reference current generation methodology in the Simulink library's blocks. The final section concludes this paper.

II. CORRELATION BETWEEN CURRENT AND POWERS

Even from the first form that was proposed in the early 1980s [12], [13], the p-q theory for three-phase three wire systems under sinusoidal voltage conditions was attractive and frequently adopted to calculate the reference currents in

systems for parallel active filtering. Further developments and contributions of other authors were focused mainly to the extension of the applicability domain [14]-[18].

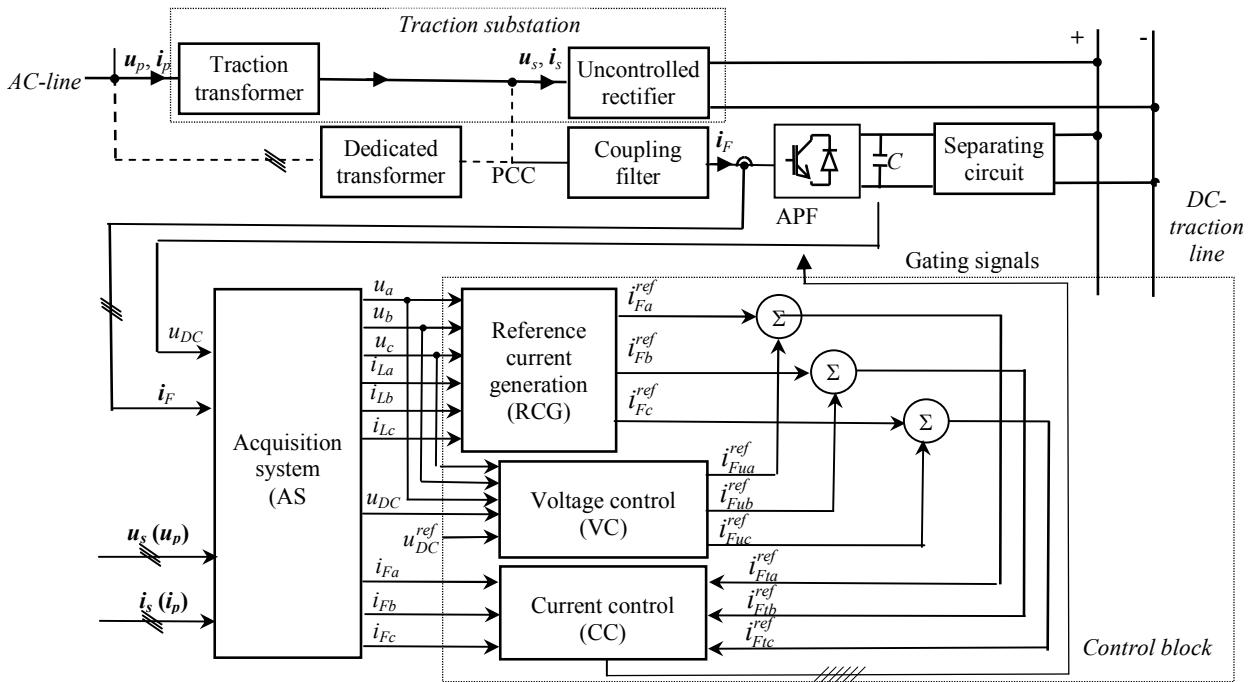

Fig. 1 Block diagram of the system for regeneration and compensation in DC-traction substations

The specificity of the theory is to express the so-called instantaneous active and reactive powers (p and q) depending on the components of voltage and current vectors \underline{u} and \underline{i} ($u_\alpha, u_\beta, i_\alpha, i_\beta$) in the stationary coordinate system (α - β). On this basis, either the components of the compensating current vector (i_{-F}^{ref}) or the components of the desired current after compensation (i_{source}^{ref}) may be expressed as a function of the imposed powers p and q .

Compared to the conventional introducing of expressions for p and q [13], highlighting them as real and imaginary parts of the complex apparent power \underline{s} is preferred, in order to allow a higher generalization [15], [16], [18]. By adopting the Clarke's power invariant transformation from phase coordinates system (a, b, c) to α - β frame [19], expression of \underline{s} ,

$$\underline{s} = 3/2 \cdot (u_\alpha + ju_\beta) \cdot (i_\alpha - ji_\beta) = p + jq \quad (1)$$

allows expressing p and q as:

$$p = 3/2 \cdot (u_\alpha i_\alpha + u_\beta i_\beta); \quad q = 3/2 \cdot (-u_\alpha i_\beta + u_\beta i_\alpha) \quad (2)$$

Since the control of APF involves the generation of the compensating current, most often depending on the powers to be compensated, it is useful to express the current starting from (1), i.e.

$$\underline{i} = 2/3 \cdot \underline{u} / |\underline{u}|^2 \cdot (p - jq) \quad (3)$$

where

$$|\underline{u}| = \sqrt{u_\alpha^2 + u_\beta^2} \quad (4)$$

is the modulus of the voltage space vector.

Depending on the practical situation and the degree of distortion of the supply voltage, the suitable compensation strategy is adopted.

III. REFERENCE CURRENT GENERATION METHODOLOGY

Considering only the operation of the system in active filtering mode, the control block in Fig. 1 makes evident the block of reference current generation (RCG) receiving from the acquisition system the voltages (u_a, u_b and u_c) and load currents (i_{La}, i_{Lb}, i_{Lc}), which are associated to the point of common coupling (PCC). In the calculation of the output currents ($i_{Fa}^{ref}, i_{Fb}^{ref}, i_{Fc}^{ref}$), the concepts of p-q theory are implemented, as shown below.

To cover the power losses and maintain the prescribed voltage on the compensating capacitor, the additional active currents ($i_{Fua}^{ref}, i_{Fub}^{ref}, i_{Fuc}^{ref}$) are generated, whose magnitude are provided by the block of voltage control (VC) [18].

Based on the total reference currents ($i_{Fia}^{ref}, i_{Fib}^{ref}, i_{Fic}^{ref}$) and the measured currents at the APF's AC-side (i_{Fa}, i_{Fb}, i_{Fc}), the current control block (CC) generates the six gating signals for IGBTs.

A. Direct Calculation of the Compensating Current under Sinusoidal Voltage

When written as a reference at the AC-side of APF for total compensation, (3) takes the following form:

$$\underline{i}_F^{ref} = 2/3 \cdot \underline{u} / |\underline{u}|^2 \cdot (p_F^{ref} - jq_F^{ref}) \quad (5)$$

where

$$p_F^{ref} = -p_- = -(p - P), \quad q_F^{ref} = q \quad (6)$$

which means that, besides p and q , the DC component (P) of p must be calculated as an average value,

$$P(t) = \frac{1}{T} \int_{t-T}^t p(\tau) d\tau \quad (7)$$

In (6), p_- is the alternating component of p .

Thus, the reference compensating current is calculated directly on the basis on the imposed instantaneous powers to be compensated.

B. Reference Current Calculation under Sinusoidal Voltage by Imposing the Remaining Current after Compensation

A simpler way of reference current generation, with fewer calculations, involves calculating the desired supply current after compensation,

$$\underline{i}_{supply}^{ref} = 2/3 \cdot \underline{u} / |\underline{u}|^2 \cdot (p_{supply}^{ref} - jq_{supply}^{ref}) \quad (8)$$

where, obviously, the desired supply active power (p_{supply}^{ref}) is the load active power and desired supply reactive power (q_{supply}^{ref}) is zero, i.e.

$$p_{supply}^{ref} = P, \quad q_{supply}^{ref} = 0 \quad (9)$$

Thus, (8) becomes:

$$\underline{i}_{supply}^{ref} = 2/3 \cdot \underline{u} / |\underline{u}|^2 \cdot P = G_e \cdot \underline{u} \quad (10)$$

where an equivalent conductance (G_e),

$$G_e = 2/3 \cdot P / |\underline{u}|^2 \quad (11)$$

has been introduced, since the square of the voltage space vector modulus is constant when the supply voltage is sinusoidal.

Then, the reference compensating current is calculated by subtracting the load current from the desired supply current,

$$\underline{i}_F^{ref} = \underline{i}_{supply}^{ref} - \underline{i}_L \quad (12)$$

C. Reference Current Calculation for UPF strategy under Nonsinusoidal Voltage

In order to obtain unity power factor after compensation,

the supply current must keep the voltage's waveform and zero-crossing instants [18]. When the supply voltage is nonsinusoidal, a nonsinusoidal current will result, with the some degree of distortion as the voltage and having the significance of an active current.

Since G_e , as calculated in (10), is not constant under nonsinusoidal voltage conditions, an adapted expression must be used for the equivalent conductance, as it was shown in [20],

$$G_{en} = 2/3 \cdot P / \left(\frac{1}{T} \int_{t-T}^t |\underline{u}|^2 d\tau \right) \quad (13)$$

D. Reference Current Calculation for PHC strategy under Nonsinusoidal Voltage

When the voltage at point of common coupling has a significant degree of distortion, as may happen in the traction transformer secondary, the compensation objective of achieving UPF cannot be taken into consideration, because it would cause the same significant harmonic distortion of the compensated current. Moreover, the current distortion is increased by the IGBTs switching in APF. In this case, the only compensation strategy that can be adopted is PHC, which involves imposing a sinusoidal supply current, in phase with the fundamental voltage. Thus, the IEEE 519-1992 recommendations regarding the current harmonic distortion [21] are met. To implement such a control, the identified algorithm involves the filtering of the measured nonsinusoidal supply voltage followed by the use of the resulted sinusoidal voltage, which is the voltage fundamental component, in the reference current generation.

In order to obtain the fundamental component of the supply voltage, it was made use of the advantages of working in the synchronous d-q reference frame, with d-axis in the direction of the voltage vector. Indeed, in the rotating reference frame, the fundamental components of voltage and current are constant quantities that can be separated through low-pass filters [22], [23].

Thus, the forward Park transformation gives the voltage space vector components in the synchronous reference frame,

$$\begin{bmatrix} u_d \\ u_q \end{bmatrix} = \begin{bmatrix} \cos(\theta) & \sin(\theta) \\ -\sin(\theta) & \cos(\theta) \end{bmatrix} \cdot \begin{bmatrix} u_\alpha \\ u_\beta \end{bmatrix} \quad (14)$$

where the rotation angle (θ) can be expressed as a function of voltage components in α - β reference frame [22]:

$$\sin(\theta) = u_\beta / |\underline{u}| = u_\beta / \sqrt{u_\alpha^2 + u_\beta^2} \quad (15)$$

$$\cos(\theta) = u_\alpha / |\underline{u}| = u_\alpha / \sqrt{u_\alpha^2 + u_\beta^2} \quad (16)$$

Then, the separated DC components (U_d , U_q) of u_d and u_q , which have the significance of being the fundamental components, are converted into the pair ($u_{1\alpha}$, $u_{1\beta}$) through the reverse Park transformation, as:

$$\begin{bmatrix} u_{1\alpha} \\ u_{1\beta} \end{bmatrix} = \begin{bmatrix} \cos(\theta) & -\sin(\theta) \\ \sin(\theta) & \cos(\theta) \end{bmatrix} \cdot \begin{bmatrix} U_d \\ U_q \end{bmatrix} \quad (17)$$

They are further used in the algorithm for generating the reference currents based on the p-q theory under sinusoidal voltage.

IV. SIMULINK LIBRARY

The founded and presented methodology for reference currents generation was modeled under Matlab/Simulink environment.

Four specific blocks have been created in accordance with the variants of calculation under sinusoidal/nonsinusoidal voltage conditions (Fig. 2). Each of them has six inputs (phase voltages and line currents in the point of common coupling) and provides the three currents to be compensated. Particular subblocks have been created for the transition from one coordinate system to another.

Where necessary, the low-pass filters have been implemented through third-order Butterworth filters with the passband edge frequency of 100π rad/s (Figs. 2 (c) and (d)).

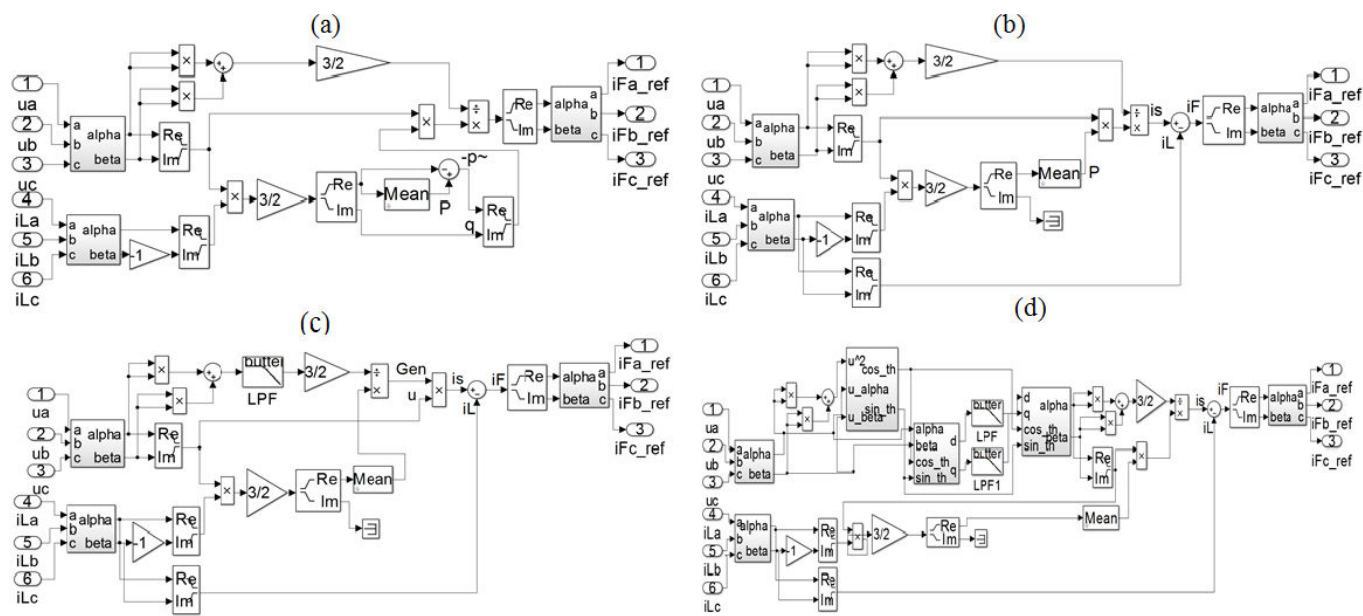

Fig. 2 (a) Block for direct calculation of the reference current, under sinusoidal voltage conditions; (b) Block for reference current calculation (RCC) based on desired supply current, under sinusoidal voltage conditions; (c) Block for RCC in the case of UPF strategy, under nonsinusoidal voltage conditions; (d) Block for RCC in the case PHC strategy, under nonsinusoidal voltage conditions

As a result, after calculating the reference compensating currents by block G_1 , the prescribed supply currents will be sinusoidal and in phase with the voltages (Fig. 6). The output current of the generation block (Fig. 7) must be tracked by the real compensating current drawn by APF from PCC. Similar results are obtained by using the block G_2 , but with a smaller amount of calculation.

A similar model of the traction substation, but with three-phase diode bridge rectifier (6-pulse rectifier) has been created (Fig. 8) for further validations of the proper operation of the blocks included in the Simulink library. As shown, the

The four blocks in Fig. 2 have been included into a Simulink library (Fig. 3) in order to be used as a part of a future experimental setup based on dSPACE control board working together with Matlab/Simulink.

V. SIMULATION RESULTS

The global Simulink models for simulation the system operation include the model of traction substation, DC traction line and reference current generation, in the variants related to the both supply voltage conditions.

For instance, the model in Fig. 4 corresponds to a traction substation with 12-pulse parallel rectifier. If APF would be connected in the transformer primary, the phase voltages in PCC are sinusoidal and the total harmonic distortion factor of the load current is of about 14% (Fig. 5).

As it can be seen, there is no reactive power, since the traction rectifier is uncontrolled.

voltages and currents in the transformer secondary are the quantities used to generate the references currents under distorted voltage conditions, in order to validate the proper operation of the blocks G_3 and G_4 for UPF and PHC strategies.

It can be seen that the current without compensation has a high degree of distortion (about 28%), whereas and the voltage harmonic distortion is of about 4% (Fig. 9).

As illustrated in Fig. 10, by using the block G_3 to generate the reference currents, the resulted currents after compensation keep the voltages' waveforms and their fundamental components are in phase with the voltages' fundamentals,

which means that unity power factor is obtained. The reference current waveform on phase a is shown in Fig. 11, along with the resulted supply current after compensation.

In order to remove the completely harmonic distortion of

the load current, including that due to the supply voltage distortion, the block G_4 was used to calculate the compensating currents.

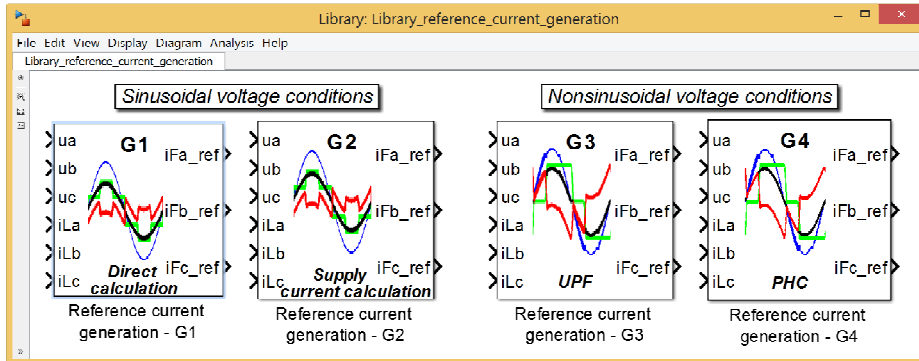

Fig. 3 The conceived Simulink library for reference current calculation

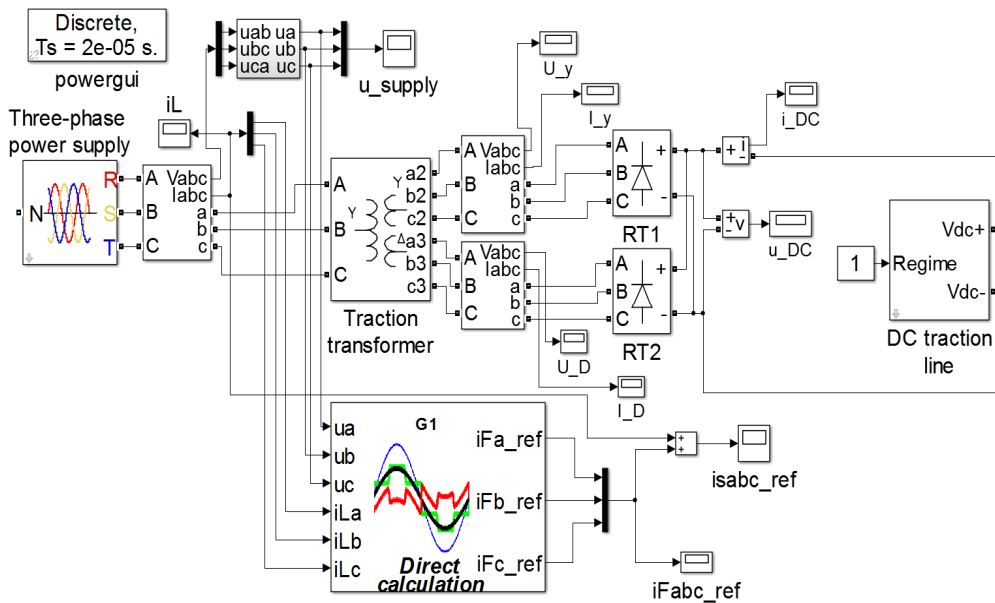

Fig. 4 Simulink model of the system with 12-pulse parallel rectifier

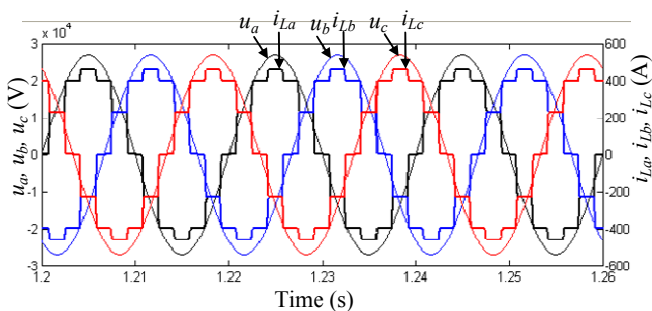

Fig. 5 Waveforms of voltages and currents in the transformer primary of a traction substation with 12-pulse parallel rectifier

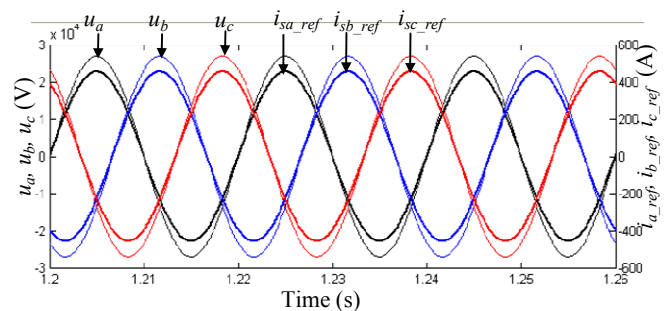

Fig. 6 Waveforms of voltages and currents after compensation, in the transformer primary of a traction substation with 12-pulse parallel rectifier

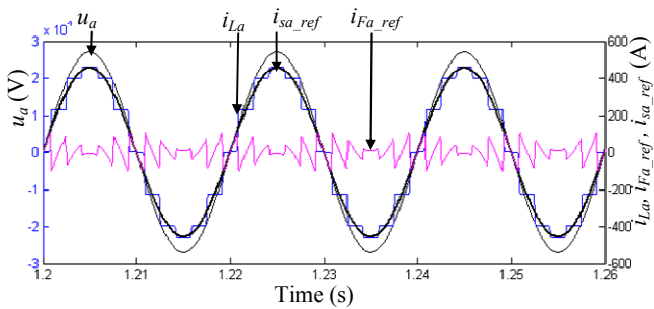

Fig. 7 Supply voltage, load current, reference compensating current and resulted supply current after compensation, when APF is connected in the transformer primary of a traction substation with 12 pulse parallel rectifier

With a reference current waveform as shown in Fig. 12, the supply current will be free of harmonics and in phase with the fundamental voltage. The waveforms in Fig. 13 prove the perfect harmonic cancellation on all three phases.

VI. CONCLUSION

This paper has presented a methodology for reference current generation that is applicable in the compensation mode of an active DC traction substation. It is based on the relationship between currents and powers, starting from the concepts of the p-q theory of the instantaneous reactive power.

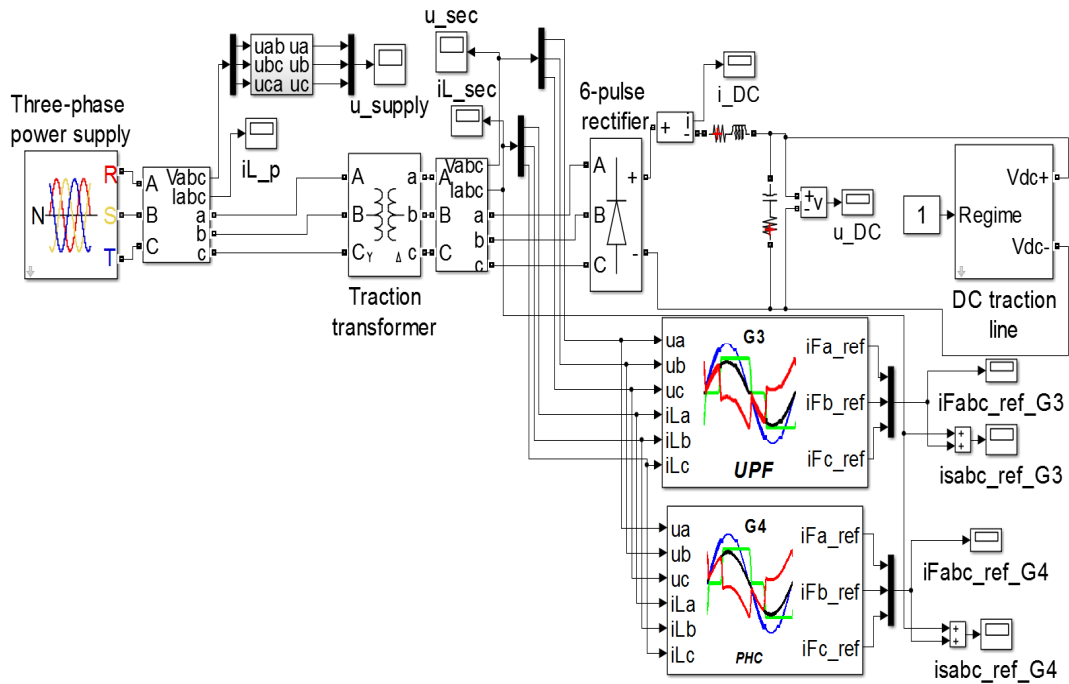

Fig. 8 Simulink model of the system with 6-pulse bridge rectifier

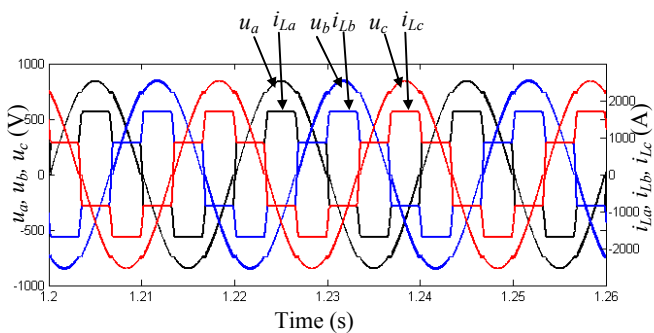

Fig. 9 Waveforms of voltages and currents in the transformer secondary of a traction substation with 6-pulse bridge rectifier

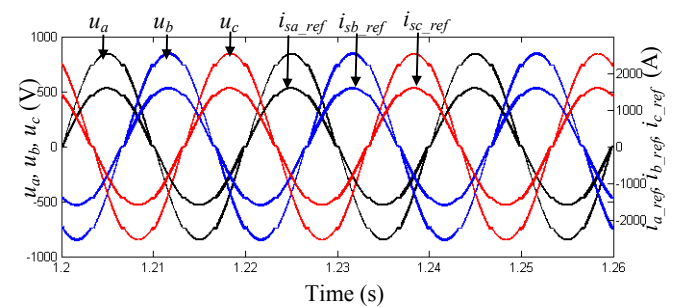

Fig. 10 Waveforms of voltages and currents after compensation, in the transformer secondary of a traction substation with 6-pulse bridge rectifier, when UPF strategy is adopted

ACKNOWLEDGMENT

This work was performed through the program Partnerships in priority areas — PN II, conducted with the financial support of MEN – UEFISCDI, project no. PN-II-PT-PCCA-2013-4-0564 (42/01.07.2014).

REFERENCES

- [1] X. Xu and B. Chen, "Study on Synthesis Control of Power Quality for Electrified Railway," in *Proc. Workshop on Power Electronics and Intelligent Transportation System*, Guangzhou, Aug 2008, pp. 110-112.
- [2] X. Xu and B. Chen, "Research on Power Quality Control for Railway Traction Power Supply System," in *Proc. Pacific-Asia Conf. Circuits, Communications and Systems*, Chengdu, May 2009, pp. 306-309.
- [3] S. J. Jang, C. Y. Choi, C. H. Bae, S. H. Song, and C. Y. Won, "Study of Regeneration Power Control Inverter for DC Traction with Active Power Filter Ability", in *Proc. 31st Annual Conf. of IEEE*, Nov. 2005.
- [4] G. Ramos, E. Cantor, M. A. Rios, and L. F. Roa, "Instantaneous p-q Theory for Harmonic Compensation with Active Power Filter in DC Traction Systems," in *Proc. 2011 International Conf. Power Engineering, Energy and Electrical Drives*, Malaga, May 2011, pp. 1-5.
- [5] P. H. Henning, H. D. Fuchs, A. D. L. Roux, and H. A. T. Mouton, "1.5-MW Seven-Cell Series-Stacked Converter as an Active Power Filter and Regeneration Converter for a DC Traction Substation," *IEEE Trans. Power Electronics*, vol. 23, no. 5, pp. 2230-2236, Sept. 2008.
- [6] Y. Warin, R. Lanselle, and M. Thiounn, "Active Substation," in *Proc. World Congress on Railway Research*, Lille, May 2011.
- [7] A. Bitoleanu, M. Popescu, *Filtre Active de Putere*. Universitaria Craiova, 2010.
- [8] A. Bitoleanu, M. Popescu, D. Marin, and M. Dobriceanu, "LCL Interface Filter Design for Shunt Active Power Filters," in *Advances in Electrical and Computer Engineering*, Vol. 10, no. 3, pp. 55-60, Aug. 2010.
- [9] A. Bitoleanu, S. Ivanov, and M. Popescu, *Convertoare Statice*. INFOMED Craiova, 1997.
- [10] A. Bitoleanu, D. Mihai, M. Popescu, and C. Constantinescu, *Convertoare Statice si Structuri de Comanda Performante*. Sitech Craiova, 2000.
- [11] J.M. Ortega, H. Ibaiondo, and A. Romo, "Kinetic Energy Recovery on Railway Systems with Feedback to the Grid," in *Proc. 9th World Congress on Railway Research*, May 22–26, 2011.
- [12] H. Akagi, Y. Kanazawa, and A. Nabae, "Generalized Theory of the Instantaneous Reactive Power in Three-Phase Circuits," in *Proc. Int. Power Electronics Conf.*, Tokyo, 1983, pp. 1375-1386.
- [13] H. Akagi, Y. Kanazawa, and A. Nabae, "Instantaneous Reactive Power Compensators Comprising Switching Devices without Energy Storage Components," *IEEE Trans. Ind. Appl.*, no. 3, pp. 625-630, 1984.
- [14] J. L. Willems, "A New Interpretation of the Akagi-Nabae Power Components for Nonsinusoidal Three-Phase Situations," *IEEE Trans. Instrum. Meas.*, vol. 41, no. 4, pp. 523-527, Aug. 1992.
- [15] H. Kim, F. Blaabjerg, B. Bak-Jensen, and J. Choi, "Instantaneous Power Compensation in Three-Phase Systems by Using p-q-r Theory," *IEEE Trans. Power Electronics*, vol. 17, no. 5, pp. 701-710, Sept. 2002.
- [16] A. Ferrero and G. Superti-Furga, "A New Approach to the Definition of Power Components in Three-Phase Systems Under Nonsinusoidal Conditions," *IEEE Trans. Instrum. Meas.*, vol. 40, pp. 568-577, June 1991.
- [17] A. Ferrero, A. P. Morando, R. Ottoboni, and G. Superti-Furga, "On the Meaning of the Park Power Components in Three-Phase Systems under Non-Sinusoidal Conditions," *ETEP*, vol. 3, pp. 33-43, Jan. 1993.
- [18] M. Popescu, A. Bitoleanu, and V. Suru, "A DSP-Based Implementation of the p-q Theory in Active Power Filtering under Nonideal Voltage Conditions," *IEEE Trans. Ind. Informat.*, vol. 9, no. 2, pp. 880-889, May 2013.
- [19] A. Bitoleanu and M. Popescu, "How can the IRP p-q Theory be Applied for Active Filtering under Nonsinusoidal Voltage Operation?," *Przeglad Elektrotechniczny*, vol. 2011, no. 1, pp. 67-71, 2011.
- [20] M. Popescu, A. Bitoleanu, and V. Suru, "Time-Domain Based Active Compensation Strategies under Nonsinusoidal Conditions in Three-Phase Three-Wire Systems," *Annals of the University of Craiova, Electrical Engineering series*, no. 35, pp.19-24, 2011.
- [21] *IEEE Recommended Practice and Requirements for Harmonic Control in Electrical Power Systems*, IEEE Std. 519-1992.

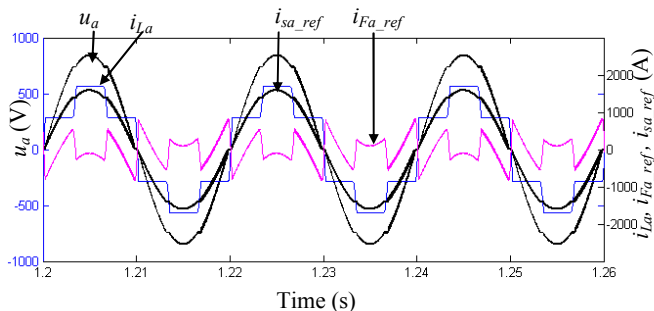

Fig. 11 Supply voltage, load current, reference compensating current and resulted supply current after compensation, when APF in connected in the transformer secondary of a traction substation with 6-pulse bridge rectifier and UPF strategy is adopted

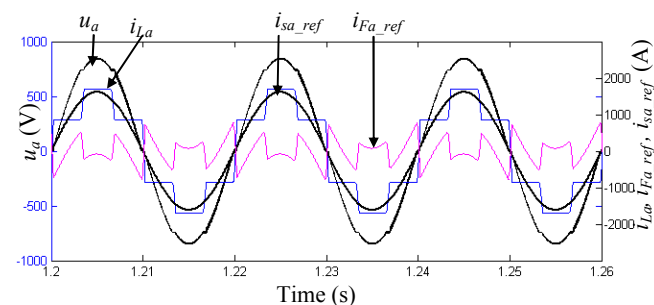

Fig. 12 Supply voltage, load current, reference compensating current and resulted supply current after compensation, when APF in connected in the transformer secondary of a traction substation with 6-pulse bridge rectifier and PHC strategy is adopted

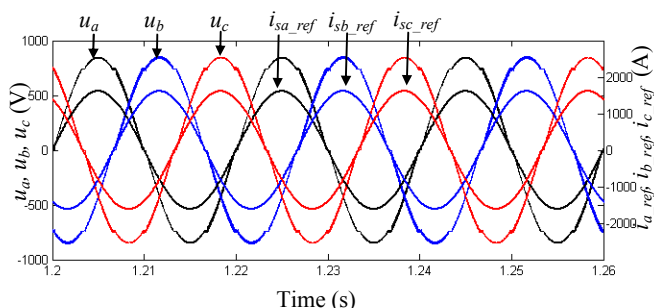

Fig. 13 Waveforms of voltages and currents after compensation, in the transformer secondary of a traction substation with 6-pulse bridge rectifier, when PHC strategy is adopted

Through a dedicated Simulink library consisting of four components, the block of calculation the prescribed currents at the APF's output can be chosen so that the global compensation is achieved. For operation under nonsinusoidal voltage, the two implemented algorithms lead to a unity power factor and perfect harmonic cancelation, respectively.

The correctness of algorithms and their implementation was successfully verified by simulation.

The further research is intended to develop and implement a specific control algorithm on an experimental setup based on dSPACE control board.

- [22] V. Soares, P. Verdelho, and G. D.Marques, "An Instantaneous Active and Reactive Current Component Method for Active Filters," *IEEE Trans. Power Electron.*, vol. 15, no. 4, pp. 660-669, 2000.
- [23] M. Kale and E. Ozdemir, "Harmonic and Reactive Power Compensation with Shunt Active Power Filter under Non-Ideal Mains Voltage", *Electric Power Systems Research*, Vol. 74, no. 3, pp. 363-370, 2005.

Mihaela Popescu (M'08–SM'14) was born in Craiova, Romania, in 1965. She received the Engineering degree and the Ph.D. degree in electrical engineering from the University of Craiova, Romania, in 1988 and 2001, respectively.

In 1992, she joined the Department of Electric Drives of Electromechanical Faculty, University of Craiova, as an Assistant. She is currently a Professor at Faculty of Electrical Engineering, University of Craiova, Romania and Director of Department of Electromechanics, Environment and Industrial Informatics. Her main field of interest includes power converters, adjustable-speed drives, active power filters, and power quality, with more than 150 journal and conference papers.

Prof. Popescu is a senior member in International Association of Computer Science and Information Technology, a member of the National Association of Electrical Drives, the Romanian Association of Electromagnetic Compatibility and the General Association of Engineers in Romania.

Alexandru Bitoleanu (M'08–SM'14) was born in Cotofeni, Romania, on November 1947. He received the Engineering degree in electrical engineering from the University of Craiova, Romania, in 1975, and the Ph.D. degree in electrical engineering from the Mines Institute Petrosani, Romania, in 1989. In 1983, he joined the Electroputere Factory from Craiova as an engineer. Since October 1978, he has been with the Department of Electrical Drives, University of Craiova, where he was an Assistant Professor, became an Lecturer in 1984, an Associate Professor in 1992, and a Professor in 1998. From 2000 to 2008 he has been the Dean of the Faculty of Electromechanics, Environment and Industrial Informatics. He is currently a Professor at Department of Electromechanics, Environment and Industrial Informatics, Faculty of Electrical Engineering, University of Craiova, Romania. He has published more than 100 scientific papers and books in the field of electrical drives, static converters, active filters and power quality. His current research interests include power electronics, electrical drives, active power filters and power quality.

Prof. Bitoleanu is an expert of the Romanian Agency for Quality Assurance in Higher Education and the National Council of Scientific Research in Higher Education. He is a member of the National Association of Electrical Drives and the Romanian Association of Electromagnetic Compatibility.