

The Study on Mechanical Properties of Graphene Using Molecular Mechanics

I-Ling Chang, Jer-An Chen

Abstract—The elastic properties and fracture of two-dimensional graphene were calculated purely from the atomic bonding (stretching and bending) based on molecular mechanics method. Considering the representative unit cell of graphene under various loading conditions, the deformations of carbon bonds and the variations of the interlayer distance could be realized numerically under the geometry constraints and minimum energy assumption. In elastic region, it was found that graphene was in-plane isotropic. Meanwhile, the in-plane deformation of the representative unit cell is not uniform along armchair direction due to the discrete and non-uniform distributions of the atoms. The fracture of graphene could be predicted using fracture criteria based on the critical bond length, over which the bond would break. It was noticed that the fracture behavior were directional dependent, which was consistent with molecular dynamics simulation results.

Keywords—Energy minimization, fracture, graphene, molecular mechanics.

I. INTRODUCTION

GRAPHENE is a one-atom-thick layer of graphite with hexagonal lattice structure, which attracted a lot of attention due to its excellent strength, flexibility and electrical/thermal conductivity [1]-[3]. Graphene can be obtained by micromechanical cleavage or repeatedly peeling with adhesive tape [4], [5]. Recently, graphene has been recognized as a promising novel material applicable in flexible displays, optical devices, chemical sensing, biosensors, ultra-capacitors, super-small transistors, and flash-like memory [2], [4], [6], [7]. For advance application, it is important to have some understanding about mechanical properties of graphene or graphite so that further development would become feasible.

Some experimental attempts [8]-[10] have been performed to characterize the properties of graphene. However, it still remains a challenge for experimentalists to carry out test and analyze experimental data at such small size-scale. Both theoretical [11], [12] and numerical methods, e.g., atomistic-continuum modelling [13], [14], first principle method [15], and molecular dynamics simulation [16]-[19], have been employed to investigate the elastic properties of graphene or graphite. Shokrieh and Rafiee [11] presented analytical formulations to predict Young's moduli of graphene sheets using a linkage between lattice molecular structure and equivalent discrete frame structure proposed by Li and Chou

[13]. Hwu and Yeh [12] derived explicit closed-form expressions of mechanical properties for graphene and carbon nanotubes on the basis of force constants of carbon covalent bonding. Li and Chou [13] proposed a structural mechanics method combined with molecular mechanics, which replaced the C-C bonds by an equivalent beam based on deformation energy equivalence. Contrary to single bond equivalent concept, [14] developed the stick-spiral models based on the energy equivalence between the basic cell of the graphene atomic structure and found that their model could provide more accurate elastic properties of graphene, especially the Poisson ratio, than the existing molecular structural mechanics models.

Molecular dynamics method has become a widely used atomic-scale simulation scheme with obvious advantage of dealing with complicated and relatively large atom systems. Several molecular dynamics simulations were implemented to examine the thickness and chirality effects on mechanical properties of graphene/graphite. Mortazavi *et al.* [18] studied the mechanical response of few-layer graphene, consisting of 2-7 atomic planes and bulk graphite, and found that the bonding strength between neighboring layers improved by increasing of the number of graphene layers, which would reduce the elastic modulus and ultimate strength. Ni *et al.* [19] investigated both the elastic and fracture behaviors of finite size graphene sheet along different directions and they observed that the fracture strain and the rupture process was loading direction dependent. Unlike the theoretical derivations and structure mechanics modeling, molecular dynamics simulations could directly deal with nonlinear interatomic interactions and large deformation condition. However, the computational efficiency of molecular dynamics method still restricts the simulated system size.

In this study, we proposed to examine the mechanical properties of infinite graphene sheet under small and large deformation based on molecular mechanics method. Instead of replacing the interatomic bonding with energy equivalent continuum structure, the deformation energy of the graphene under loading would be directly related to the bond changes. Considering the representative unit cell, the changes of bond lengths and angles under external loadings could be realized numerically under the geometry relations and minimum energy assumption. Various loadings, e.g., uniaxial, biaxial, simple tension, and pure shear, could be applied on the representative unit cell to extract the elastic properties of graphene at small deformation. Moreover, the fracture behavior of graphene along different loading directions would be studied as well.

I-Ling Chang is with the Department of Mechanical Engineering, National Cheng Kung University, Tainan 70101, Taiwan (corresponding author to provide phone: 8866-275-7575ext.62124; fax: 8866-235-2973; e-mail: ilchang@mail.ncku.edu.tw).

Jer-An Chen was a graduate student with the Department of Mechanical Engineering, National Cheng Kung University, Tainan 70101, Taiwan (e-mail: pedophilia103@hotmail.com).

II. THEORETICAL MODELING

The graphene is consisted by carbon hexagonal honeycomb lattice structure as shown in Fig. 1. From the viewpoint of molecular mechanics, the carbon atoms are taken as mass points and the interaction between atoms could be described by force fields. The interactions energy between atoms could be written as:

$$U = U_\rho + U_\theta + U_\omega + U_\tau + U_{vdW} + U_{es} \quad (1)$$

where U_ρ , U_θ , U_ω , and U_τ are bonded energies of stretching, angle, inversion, and torsion, respectively; U_{vdW} and U_{es} are energies of non-bonded van der Waals interaction and electrostatic interaction. Regarding the in-plan loading of graphene, the energies of bond inversion and torsion are negligible. Moreover, the non-bonded interactions, i.e., van der Waals interaction and electrostatic interaction, have less contribution on a covalent system and will be neglected in the graphene sheet as well. Hence, the total interatomic potential energy is mainly contributed by bond stretching and angle variation for graphene, which can be described by spring models as:

$$U = \frac{1}{2} \sum K_r (\Delta r)^2 + \frac{1}{2} \sum K_\theta (\Delta \theta)^2 \quad (2)$$

where Δr and $\Delta \theta$ are the changes of bond length and bond angle from the equilibrium; K_r and K_θ are the corresponding force constants of bond stretching and angle variation caused by C-C bonding.

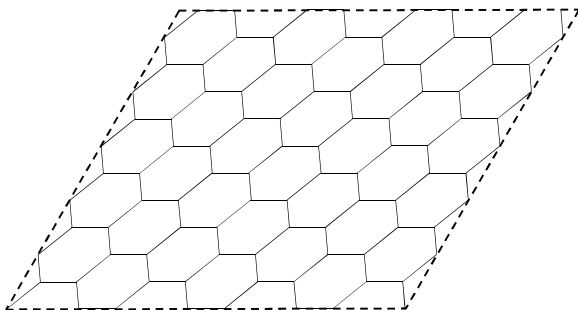

Fig. 1 The schematic illustration of 2D graphene

First consider an infinite graphene sheet under in-plane loading, it is obvious that every hexagonal lattice would deform in the same way. Hence, we could study the deformation of the representative unit cell as shown in Fig. 2. At equilibrium, the equilibrated C-C bond length, a , and bond angle, θ , of the graphene are 1.42 \AA and $\frac{2}{3}\pi$, respectively; the lengths, L_x and L_y , of the representative unit cell are $\sqrt{3}a$ and $2a$. We will consider two types of in-plane loadings, i.e., biaxial and shear. Assume the graphene is sustaining biaxial loading, ϵ_x and ϵ_y , as shown in Fig. 2 (b), the deformation of the representative unit cell could be described by two bond lengths, a_x and a_y , and two bond angles, α and β , due to symmetry and periodicity. The angle between a_x and a_y is denoted as α and that between

a_x and a_y is named as β . There are three geometry constraints needed to be satisfied.

(1) Angle relation:

$$2\alpha + \beta = 2\pi \quad (3)$$

(2) Length condition along y -direction:

$$L_y + \Delta L_y = 2a_y + 2 \left[a_x \cos \frac{\beta}{2} - \frac{a}{2} \right] \quad (4)$$

(3) Length condition along x -direction:

$$(L_x + \Delta L_x)^2 = 2a_x^2 - 2a_x^2 \cos \beta \quad (5)$$

where $\Delta L_{x,y}$ is the unit cell length variation along x - and y -directions under biaxial strains, ϵ_x and ϵ_y . The total deformation energy of the unit cell caused by the biaxial loading can be expressed as:

$$U = 4 \times \frac{1}{2} K_x \Delta a_x^2 + 2 \times \frac{1}{2} K_r \Delta a_y^2 + 8 \times \frac{1}{2} K_\theta \Delta \alpha^2 + 4 \times \frac{1}{2} K_\theta \Delta \beta^2 \quad (6)$$

$$\Delta a_{x,y} = a_{x,y} - a \quad (7)$$

$$\Delta \alpha(\beta) = \alpha(\beta) - \frac{2}{3}\pi \quad (8)$$

where $\Delta a_{x,y}$ and $\Delta \alpha(\beta)$ are bond length and angle changes from the equilibrium values. Here in this research, it is assumed the force constants $K_r = 6.517 \times 10^{-18} \text{ J-\AA}^{-2}$ and $K_\theta = 8.754 \times 10^{-19} \text{ J}$. [20] At equilibrium, the total deformation energy of the unit cell is zero. The deformation of the representative unit cell could be described by six unknowns, i.e., ΔL_x , ΔL_y , a_x , a_y , α and β . Given the biaxial loading strains, ϵ_x and ϵ_y , combining with three geometry constraint conditions, it is still required to have one more equation in order to realize the deformation of the unit cell. It is assumed that the changes of bond lengths and angles will make the total deformation energy of the unit cell minimum. Hence, the elastic properties of the graphene could be calculated based on small loading strains and deformation energy density. Besides, it is also easy to figure out the deformation of the graphene under uniaxial loading (given ϵ_x , zero ϵ_y ; given ϵ_y , zero ϵ_x), which is a special case for in-plane biaxial loading. As for simple tension loading (given ϵ_x , zero σ_y ; given ϵ_y , zero σ_x), either ΔL_x or ΔL_y is given. Combined with three geometry constraint conditions, we need to determine two unknowns based on minimum energy assumption. Nelder-Mead multidimensional unconstrained minimization method is adopted to find these two parameters that would minimize the total deformation energy of the unit cell. Thus, the deformation of the graphene under simple tension loading could be determined.

Similarly for pure shear in-plane loading, γ_{xy} , as shown in Fig. 3 (a), the deformation of the representative unit cell could be described by three bond lengths, a_{x1} , a_{x2} , a_y and three bond angles, α_1 , α_2 , β . Since it is pure shear loading, the side lengths of the unit cell will remain the same. However, the

deformations of the bonds need to satisfy some geometry constraints under the limitation of periodic and symmetry conditions. These constraints are:

(1) Length condition

$$\frac{1}{2}L_y \cos \gamma = L_1 \cos \theta_1 + a_y \cos \theta_2 \quad (9)$$

$$\frac{1}{2}L_y \sin \gamma = L_1 \sin \theta_1 + a_y \sin \theta_2 \quad (10)$$

(2) Bond length conditions

The geometry relations of bond length, a_{x1} and a_{x2} , can be generated by using the law of cosines applied to the angle $\angle ADB$ and $\angle A'DB$ of the triangles $\triangle ADB$ and $\triangle A'DB$ as shown in Fig. 3 (b).

$$a_{x1}^2 = L_1^2 + \left(\frac{L_x}{2}\right)^2 - 2L_1 \left(\frac{L_x}{2}\right) \cos\left(\frac{\pi}{2} + \theta_1\right) \quad (11)$$

$$a_{x2}^2 = L_1^2 + \left(\frac{L_x}{2}\right)^2 - 2L_1 \left(\frac{L_x}{2}\right) \cos\left(\frac{\pi}{2} - \theta_1\right) \quad (12)$$

(3) Bond angle conditions

The geometry relations for bond angles, α_1 , α_2 and β , can be expressed using the law of cosines applied to the angle $\angle ABD$, $\angle A'BD$ and $\angle ABA'$ of the triangles $\triangle ADB$, $\triangle A'DB$, $\triangle ABA'$

$$\left(\frac{L_x}{2}\right)^2 = a_{x1}^2 + L_1^2 - 2a_{x1}L_1 \cos(\pi - \alpha_1 - (\theta_1 - \theta_2)) \quad (13)$$

$$\left(\frac{L_x}{2}\right)^2 = a_{x2}^2 + L_1^2 - 2a_{x2}L_1 \cos(\pi - \alpha_2 - (\theta_1 - \theta_2)) \quad (14)$$

$$L_x^2 = a_{x1}^2 + a_{x2}^2 - 2a_{x1}a_{x2} \cos \beta$$

The total deformation energy caused by pure shear loading due to the changes of the bond lengths and bond angles in the unit cell can be expressed as:

$$U = 2 \times \frac{1}{2} K_r \Delta a_{x1}^2 + 2 \times \frac{1}{2} K_r \Delta a_{x2}^2 + 2 \times \frac{1}{2} K_r \Delta a_y^2 + 4 \times \frac{1}{2} K_\theta \Delta \alpha_1^2 + 4 \times \frac{1}{2} K_\theta \Delta \alpha_2^2 + 4 \times \frac{1}{2} K_\theta \Delta \beta^2 \quad (15)$$

$$\Delta a_{x1,x2} = a_{x1,x2} - a \quad (16)$$

$$\Delta \alpha_{1,2} = \alpha_{1,2} - \frac{2}{3}\pi \quad (17)$$

$$\Delta \beta = \beta - \frac{2}{3}\pi \quad (18)$$

The number of variables used for 2D shearing model is ten (L_1 , θ_1 , θ_2 , a_{x1} , a_{x2} , a_y , α_1 , α_2 , β and γ) in the unit cell. Given the shear loading strains, γ , combining with seven geometry constraint conditions, we could reduce the number of unknowns to two in order to realize the deformation of the unit cell. Nelder-Mead multidimensional unconstrained minimization method is adopted to find these two parameters that would minimize the total deformation energy of the unit cell. Consequently, the shear properties of the graphene could be calculated based on small loading strains and deformation energy density.

The deformation of the representative unit cell under either biaxial or shear loading could be realized irrespective of small or large strain. Hence, the fracture strain could be predicted under the critical bond length assumption as fracture criteria. It is assumed that the bond would break when the bond length reaches 1.83 Å [19].

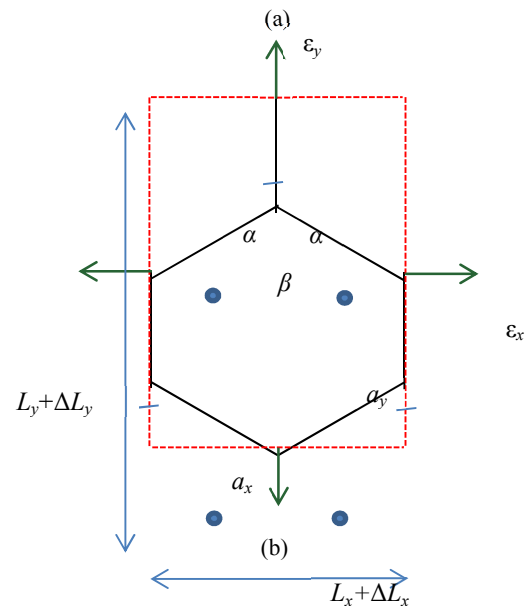
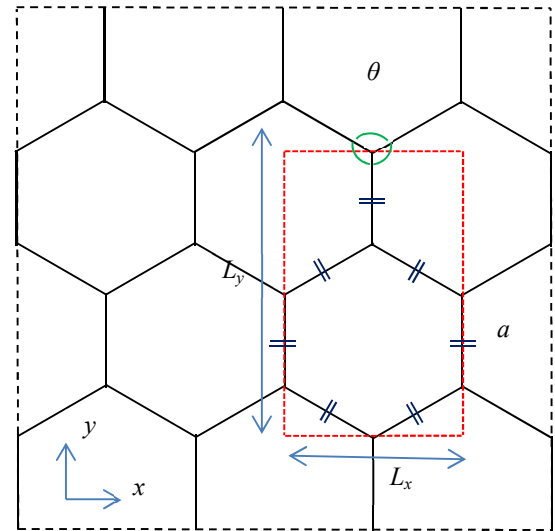

Fig. 2 The schematic illustrations of graphene (a) at equilibrium and (b) under biaxial loading (The representative unit cell is indicated by red dash line)

III. RESULTS AND DISCUSSION

The displacements of atoms inside the representative unit cell of two-dimensional graphene were calculated purely from the atomic bonding (stretching and bending) and non-bonding (van der Waal) energies using molecular mechanics method. Various loading conditions were applied to extract the elastic

properties of graphene at small deformation and examine their fracture behaviors at larger loading.

$$\begin{Bmatrix} \sigma_x \\ \sigma_y \\ \sigma_{xy} \end{Bmatrix} = \begin{bmatrix} C_{11} & C_{12} & C_{16} \\ C_{12} & C_{22} & C_{26} \\ C_{16} & C_{26} & C_{66} \end{bmatrix} \begin{Bmatrix} \varepsilon_x \\ \varepsilon_y \\ \gamma_{xy} \end{Bmatrix} \quad (20)$$

The relation between strain energy density and strains can be expressed as:

$$u = \int \sigma_x d\varepsilon_x + \int \sigma_y d\varepsilon_y + \int \sigma_{xy} d\gamma_{xy} \quad (21)$$

The elastic constants of graphene can be calculated from various in-plane loadings. Take uniaxial loading in x direction (given ε_x , zero $\varepsilon_y, \gamma_{xy}$) as an example, the strain energy density can be written as $u = \frac{1}{2} C_{11} \varepsilon_x^2$. Fig. 4 illustrates the relation between strain energy density of the graphene and applied loading strain under uniaxial and simple tension loadings along both in-plane (x and y) directions. It is clear to observe that strain energy density, u , is proportional to ε^2 at small deformation (strain < 0.001) and the graphene is directional dependent at larger strain. Hence, the stiffness matrix of the graphene could be calculated under various small strain loading conditions based on molecular mechanics as:

$$[C] = \begin{bmatrix} 870.4 & 236.7 & 0 \\ & 870.4 & 0 \\ (symm) & & 317.2 \end{bmatrix} \text{ (GPa)}$$

The elastic constants are the same along both in-plane directions. If simple tension (given ε_x , zero σ_y, γ_{xy}) is applied to the unit cell, Young's modulus of the graphene could be calculated from strain energy density, $u = \frac{1}{2} E_x \varepsilon_x^2$, and Poisson's ratio relating to transverse contraction could be figured out from the deformation of the unit cell ($\Delta L_x, \Delta L_y$). It is found that the Young's moduli, E_x, E_y , and Poisson's ratios, ν_{xy}, ν_{yx} , of the graphene are 805.6 GPa and 0.27, respectively. It is noticed that the shear modulus, C_{66} , Young's modulus and Poisson's ratio satisfy the relation $C_{66} = \frac{E}{2(1+\nu)}$, which indicates that the graphene is in-plane isotropic. Our calculated Young's moduli and Poisson's ratios are consistent with the values based on the closed form solution [12] and stick-spiral model [14] while adopting the same set of force constants.

Since the deformation of the graphene under loading could be determined under minimum energy assumption, it is interesting to examine the strain distribution inside the unit cell. The atomic arrangement in the unit cell is discrete and not symmetric in y direction. Hence, the unit cell could be divided into two zones based on geometry similarity as shown in Fig. 5 (a). The normal and shear strain at each zone are defined following the conventional definitions:

$$\varepsilon_y^{(1)} = \frac{(a_x \cos \frac{\beta}{2} - \frac{1}{2}a)}{\frac{1}{2}a}, \varepsilon_y^{(2)} = \frac{(a_y - a)}{a}, \gamma_{xy}^{(1)} = \theta_1, \gamma_{xy}^{(2)} = \theta_2. \quad (22)$$

Figs. 5 (b) and (c) show the strain distributions of these two zones under simple tension loading along y direction and pure shear. It is obvious to notice that the strain along y direction is not uniform inside the unit cell and nonlinear when the applied

Open Science Index, Mechanical and Mechatronics Engineering Vol:9, No:7, 2015 publications.waset.org/10001935.pdf

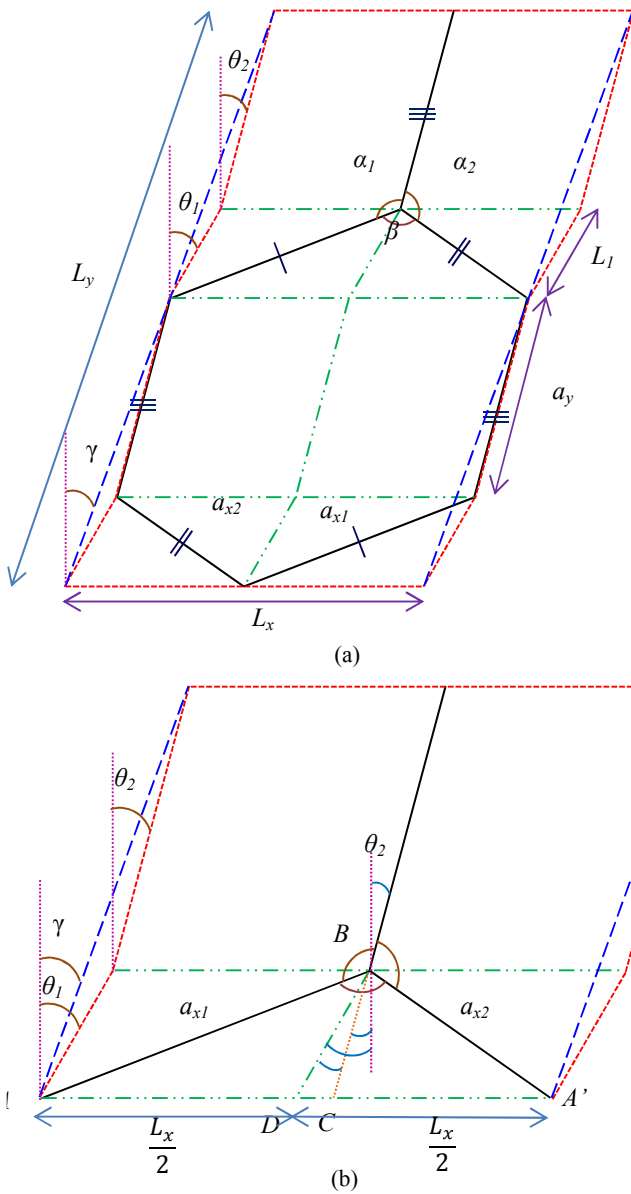

Fig. 3 The schematic illustrations of graphene under pure shear. (a) The unit cell and (b) the top half of the unit cell (The representative unit cell is indicated by red dash line)

The strain energy density of the graphene under various loading conditions can be calculated based on minimum energy assumption as:

$$u = \frac{U}{L_x L_y d_o} \quad (19)$$

where d_o is the thickness of graphene and taken as 3.4 Å. Since graphene is a single layer material, the elastic stiffness matrix can be simplified as:

strain is large. Zone 1 is softer under simple tension but stiffer under shear loading as compared to zone 2.

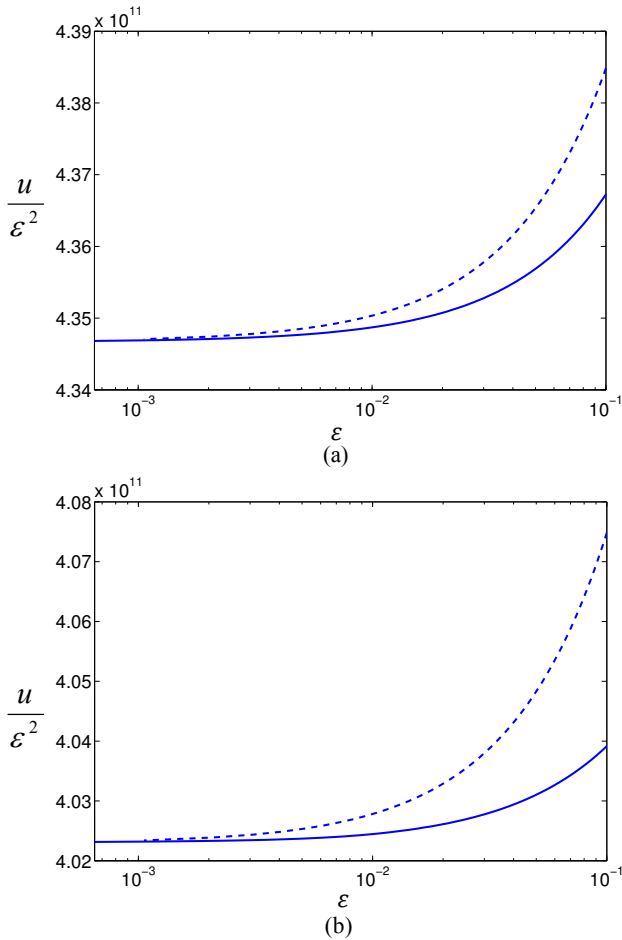

Fig. 4 The relations between strain energy densities and applied strains under (a) uniaxial and (b) simple tension loading (Dash line indicates loading along x direction; solid line represents tension along y direction)

The fracture strain for graphene can be estimated based on fracture criteria of critical bond length, at which the bond will tend to break. The critical bond length is assumed as 1.83 \AA . [19] Here, we only considered the graphene fracture strain under simple tension along two in-plane directions, i.e., x (armchair) and y (zigzag).

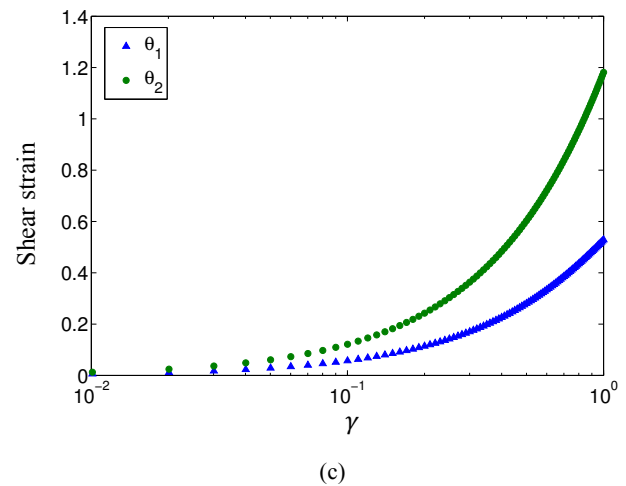
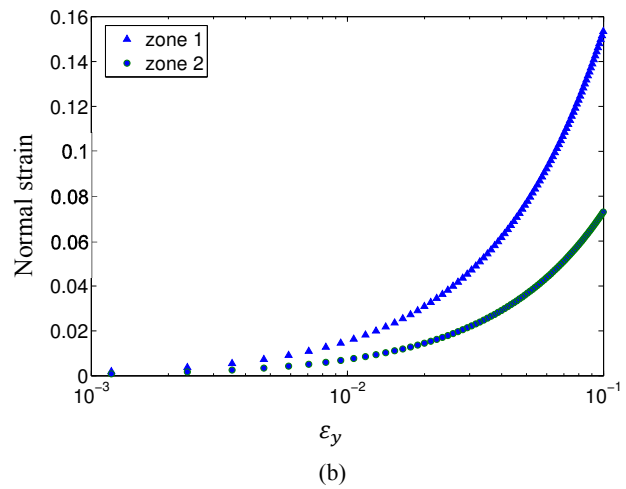
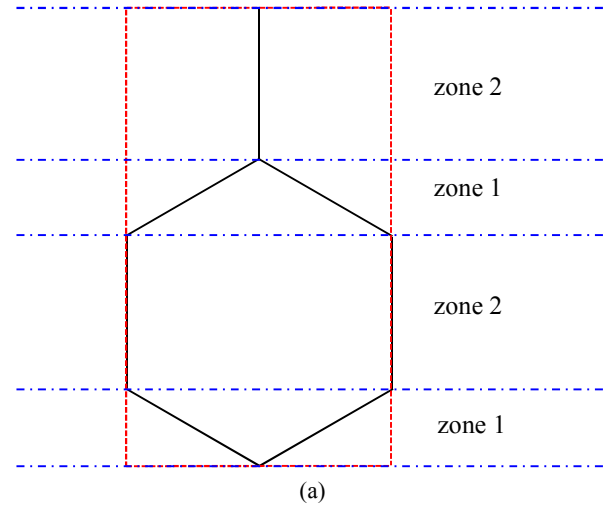

Fig. 5 (a) The illustration of the divided zones based on geometry similarity. The strain distributions at two zones under (b) simple tension loading along y direction and (c) pure shear strain

The bond lengths of graphene subjected to simple tension loading could be evaluated based on minimum energy assumption and the bond length changes (Δa_x , Δa_y) under different strains are shown in Fig. 6. The dotted line indicates the critical bond length change, from which the fracture strain

could be determined. It is also noticed that one of the bonds (a_y) almost remain the same as the equilibrium bond length and a_x bond would break first while loading along armchair edge, i.e. x direction. The a_y bond would reach critical bond length faster when loading along zigzag edge. Moreover, the fracture strains are 0.43 and 0.38 while loading along armchair and zigzag edges of graphene. This trend is consistent with molecular dynamics simulation results [19]. The fracture behavior of graphene is loading direction dependent while contrasting to the elastic behavior. Moreover, it is worth to point out that the estimation of fracture strain is not limited to simple tension loading. Similar prediction on fracture strain based on critical bond length could be applied to various loading conditions, e.g. shear, biaxial and combined loadings.

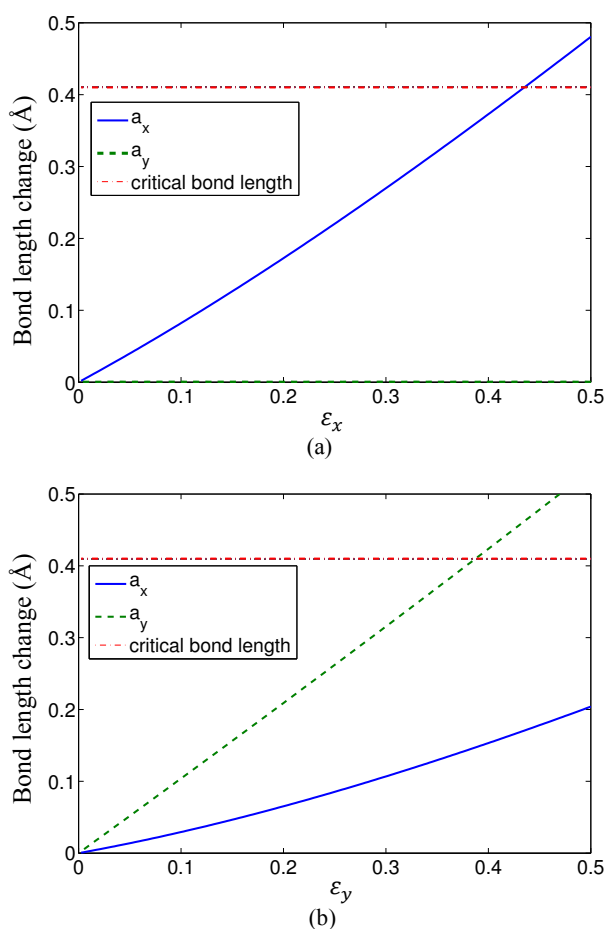

Fig. 6 The bond length changes of graphene under simple tension loading along (a) armchair and (b) zigzag edges

IV. CONCLUSIONS

In this study, the representative unit cell of 2D graphene was considered and the deformation of the unit cell under various loading conditions, e.g., in-plane/out-of-plane, biaxial/shear, could be realized based on molecular mechanics. In molecular mechanics, the interaction between carbon atoms could be described by force fields. It is assumed that the deformation of the unit cell needs to satisfy the geometry constraints and

minimum energy requirement. The elastic properties of graphene could be calculated from the strain energy density of the unit cell at small deformation (strain < 0.001). It is found in elastic region that graphene is in-plane isotropic. When the loading strain is larger, it is noticed that strain is not uniform and nonlinear inside the unit cell. Zone 1 is softer under uniaxial tension but stiffer under shear loading as compared to zone 2. Adopting fracture criteria based on critical bond length, it is predicted that the fracture strain along zigzag edge is lower than that along armchair edge of graphene, which is consistent with molecular dynamics simulation results. It is concluded that the fracture behavior of graphene is loading direction dependent contrasting to the elastic behavior.

ACKNOWLEDGMENT

This study was supported by the National Science Council of Taiwan under grant NSC 102-2221-E-006-038 and NSC 101-2221-E-006-104-MY3.

REFERENCES

- [1] A.K. Geim, K.S. Novoselov, "The rise of graphene," *Nat. Mater.*, vol. 6, pp. 183-191, 2007.
- [2] M. Ariza, M. Ortiz, "Discrete dislocations in graphene," *J. Mech. and Phys. Solids*, vol. 58, pp. 710-734, 2010.
- [3] T. Chang, "A molecular based anisotropic shell model for single-walled carbon nanotubes," *J. Mech. and Phys. Solids*, vol. 58, pp. 1422-1433, 2010.
- [4] K.S. Novoselov, A.K. Geim, S. Morozov, D. Jiang, Y. Zhang, S. Dubonos, et al., "Electric field effect in atomically thin carbon films," *Science*, vol. 306, pp. 666-669, 2004.
- [5] K. Novoselov, D. Jiang, F. Schedin, T. Booth, V. Khotkevich, S. Morozov, et al., "Two-dimensional atomic crystals," *P. Natl. Acad. Sci. USA*, vol. 102 pp. 10451-10453, 2005.
- [6] B.F. Machado, P. Serp, "Graphene-based materials for catalysis," *Catal. Sci. Tech.*, vol. 2, pp. 54-75, 2012.
- [7] J. Wu, Y. Wei, "Grain misorientation and grain-boundary rotation dependent mechanical properties in polycrystalline graphene," *J. Mech. and Phys. Solids*, vol. 61, pp. 1421-1432, 2013.
- [8] J.S. Bunch, S.S. Verbridge, J.S. Alden, A.M. van der Zande, J.M. Parpia, H.G. Craighead, et al., "Impermeable atomic membranes from graphene sheets," *Nano Lett.*, vol. 8, pp. 2458-2462, 2008.
- [9] J.S. Bunch, A.M. Van Der Zande, S.S. Verbridge, I.W. Frank, D.M. Tanenbaum, J.M. Parpia, et al., "Electromechanical resonators from graphene sheets," *Science*, vol. 315, pp. 490-493, 2007.
- [10] X. Liu, T.H. Metcalf, J.T. Robinson, B.H. Houston, F. Scarpa, "Shear modulus of monolayer graphene prepared by chemical vapor deposition," *Nano Lett.*, vol. 12, pp. 1013-1017, 2012.
- [11] M.M. Shokrieh, R. Rafiee, "Prediction of Young's modulus of graphene sheets and carbon nanotubes using nanoscale continuum mechanics approach," *Mater. Design*, vol. 31, pp. 790-795, 2010.
- [12] C. Hwu, Y.-K. Yeh, "Explicit expressions of mechanical properties for graphene sheets and carbon nanotubes via a molecular-continuum model," *Appl. Phys. A*, vol. 116, pp. 125-140, 2014.
- [13] C. Li, T.-W. Chou, "A structural mechanics approach for the analysis of carbon nanotubes," *Int. J. Solids Struct.*, vol. 40, pp. 2487-2499, 2003.
- [14] Y.Z. Cheng, G.Y. Shi, "The prediction of mechanical properties of graphene by molecular mechanics and structural mechanics method," *Adv. Mat. Res.*, vol. 583, pp. 403-407, 2012.
- [15] F. Liu, P. Ming, J. Li, "Ab initio calculation of ideal strength and phonon instability of graphene under tension," *Phys. Rev. B*, vol. 76, pp. 064120, 2007.
- [16] M. Neek-Amal, F. Peeters, "Nanoindentation of a circular sheet of bilayer graphene," *Phys. Rev. B*, vol. 81, pp. 235421, 2010.
- [17] K. Min, N. Aluru, "Mechanical properties of graphene under shear deformation," *Appl. Phys. Lett.*, vol. 98, pp. 013113, 2011.
- [18] B. Mortazavi, Y. Rémond, S. Ahzi, V. Toniazzo, "Thickness and chirality effects on tensile behavior of few-layer graphene by molecular dynamics simulations," *Comp. Mater. Sci.*, vol. 53, pp. 298-302, 2012.

- [19] Z. Ni, H. Bu, M. Zou, H. Yi, K. Bi, Y. Chen, "Anisotropic mechanical properties of graphene sheets from molecular dynamics," *Physica B*, vol. 405, pp. 1301-1306, 2010.
- [20] W.D. Cornell, P. Cieplak, C.I. Bayly, I.R. Gould, K.M. Merz, D.M. Ferguson, et al., "A second generation force field for the simulation of proteins, nucleic acids, and organic molecules," *J. Am. Chem. Soc.*, vol. 117, pp. 5179-5197, 1995.

I-Ling Chang was born in Tainan, Taiwan on Aug. 21st, 1974. She received her B.S. degree on Physics from National Taiwan University, Taipei, Taiwan in 1996, and M.S. and Ph.D. degrees in Aeronautics and Astronautics Engineering, Purdue University, USA in 1999 and 2004, respectively.

After graduation, she has been a faculty member of Mechanical Engineering Department, National Chung Cheng and Cheng Kung University consequently, where she is now an associate professor. Her main research focus is on property characterizations of nanomaterials/nanostructures and phononics.