

A New Center of Motion in Cabling Robots

A. Abbasi Moshaii, F. Najafi

Abstract—In this paper a new model for center of motion creating is proposed. This new method uses cables. So, it is very useful in robots because it is light and has easy assembling process. In the robots which need to be in touch with some things this method is so useful. It will be described in the following. The accuracy of the idea is proved by two experiments. This system could be used in the robots which need a fixed point in the contact with some things and make a circular motion.

Keywords—Center of Motion, Robotic cables, permanent touching.

I. INTRODUCTION

THERE are lots of robots which need to rotate an instrument about a point or for best doing their work they need to rotate a part about its tip. This point is center of motion which whole of a solid body rotates about it. So the importance of having a system which can make a center of rotation point is felt. There are a lot of works which want to make a center of motion point. On the other hand, some of these mechanisms were very heavy so they could not be used in a robot or in some other uses such as medical systems [1].

Funda et al. [2] used a six-bar pantograph to make a center of motion in a surgery device which could rotate about a point on the surface of the patient's body. Bauman et al. [3] made a spherical remote-center-of-motion parallel manipulator for force reflection. It used a pantograph which would be used in other mechanisms after that. Salcudean et al. [4] used a pantograph to generate a conical motion about a center-of-motion point. In this pantograph the intersection of the second and last link of the pantograph generates the center of motion. Mitsuishi et al. [5] and Koizumi et al. [6] created a system with circular guides. In their system the center of the gears fixed to the circular guides, and this center point is the center of motion. Vilchis et al. [7] created center of motion by cabling system and moving the rigid body in a circular path, where its center determines the center of motion of the mechanism.

The European OTELO project described by [8] generated a fixed point (center of motion) on a patient's body. The combination of two concentric circular arms which are actuated by motors created the center of motion of the mechanism. The end of the end effector is placed at the center of motion point. Stoianovici et al. [9] constructed a remote center of motion robotic system including a base unit and a

plurality of linking units. The base unit is rotatable about a first axis. The units are coupled with another. At least two of the linking units are kept parallel to each other during motion. They are coupled with that base unit at a first end and rotatable about a second axis by changing an angle between each of the plurality of links. Vilchis-Gonzalez et al. [10] designed and constructed a 4-dof robotic arm, called TERMI. The device uses some pinion gears in a serial configuration powering some circular sliders in this device which is similar to the robotic device developed by [5] and [6].

Najafi and Sepehri [11] designed and constructed a device which could move in a hemispherical workspace. To do that, they used two six-bar perpendicular pantographs connected together by a revolute joint. Moving the pantographs via two actuators allows the revolute joint to travel over a hemispherical workspace. So the tip of the instrument could be fixed and it is the center of motion.

Ito et al. [12] designed a robotic system which could make center of motion. This mechanism has three circular gears which make the hemispherical workspace. So, the center of motion of the mechanism is located at the center of hemisphere created by these gears.

In this paper a new system to produce a variable center of motion is introduced and it lightens the mechanism for generating the center. To produce the center of motion cabling system is used. It is because of cables properties such as low weight and flexibility.

II. CONCEPT OF DESIGN

A. Base of the Method

In this system the part of robot which should have a fix tip is installed in the middle. This fact is used: if there are two parallel velocity vectors and two lines which connect beginning and end of them, intersection point of these two lines is the center of motion. If the places of these velocities are adjusted such that the intersection point coincides with the tip of the rotary part of the robot, this point could be fixed center of motion. In this method cables keep the contact between this part and outside things, it's because of the structural shape described later.

B. Mechanism Design

Fig. 1 shows the internal structure of this system. The rotary part of robot is set at the middle of it and side pulleys make a rotation in the ending pulleys by cables.

If velocities which are parallel are produced and placed in good positions, center of motion could be generated. For this desire, Thales theory is used and ending pulleys are placed in the ratio of 1.5 in vertical distance from tip of the part. So the velocities should be in the ratio of 1.5.

A. Abbasi Moshaii is with the Mechanical Engineering Department, University of Tarbiat Modares, Tehran, Iran, (e-mail: a.abasemoshaii@modares.ac.ir).

F. Najafi is with the Mechanical Engineering Department, University of Tehran, Tehran, Iran, (corresponding author to provide phone: +98-21-88003328; fax: +98-21-88003328; e-mail: Farshid_najafi@ut.ac.ir).

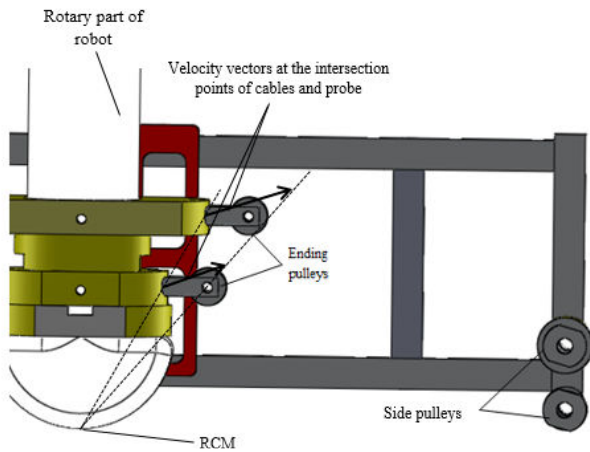

Fig. 1 Positioning of different parts of the mechanism

To describe generation of this ratio, describing of the side pulleys working is needed. As you can see in Fig. 2 when cable goes through the system and reaches upper right pulley, it spins about the upper right pulley. Then this cable goes back to the motor. The pulleys are joint together so other pulleys rotate with it. A cable which is connected with upper middle pulley goes to another pulley and after wrapping about it (Fig. 2), attached to the part by a screw. Thus rotation of the pulley pulls the part. Upper left pulley is engaged with its underside pulley. So as like as upper pulleys bottom pulleys are engaged together. Bottom middle pulley works as like as upper middle pulley. Consequently the part is pulled from two points.

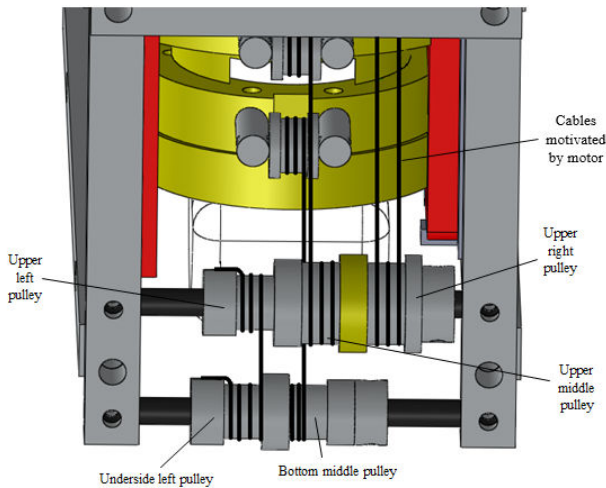

Fig. 2 Side pulleys motivation

As can be seen in Fig. 2 diameter of upper middle pulley is in 1.5 scales bigger than the bottom middle pulley. So because of connection between left pulleys their rotational speeds are equal. This scale means that the velocity of upper cable is in 1.5 scales bigger than bottom cable which comes from side pulleys to ending pulleys. Velocity vectors which are pulling the part are from this part to ending pulleys (Fig. 3), consequently the velocities remain parallel during examination along with movements of things. Thus the center coincides

with the tip of the part and it moves by things movements consequently the variable center of motion is created.

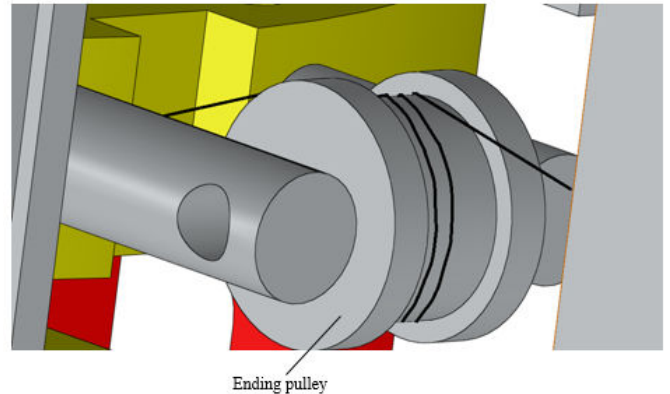

Fig. 3 Cables end that pull the rotary part

In this method contact between outdoor things and robot is kept by cables, because the section goes up and down along with things and this movement put cables in tension. If the cables want to increase their length they turn pulleys because of their connection to them, so pulleys must rotate but if they rotate they compel motor to turn and motor doesn't turn so cables stretch and this stretching puts a force on the rotary part which presses that to the thing. Thus it has a permanent contact.

III. EXPERIMENT AND MANUFACTURING

The system was designed and manufactured and two experiments were devised to verify its accuracy. Fig. 4 shows the device and Fig. 7 shows the experiment environment.

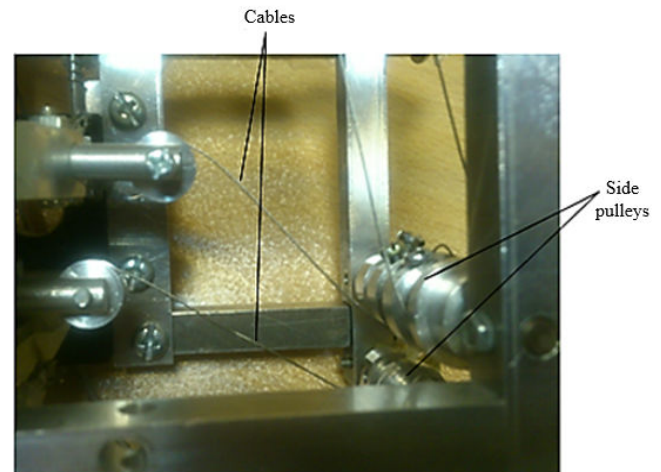

Fig. 4 Prototype of the device

The experiment consists of the mechanism, circuit, electricity source, laser pointer, and laser kit. Laser pointer is installed on the tip of the part to send light to the lamp in the laser kit (Fig. 5). Laser kit has a sensor which enlighten the lamp when receive the light (Fig. 6). The result was that all of the time the laser kit lamp was brightening (Fig. 7). By equal

changing the height of the sensor and the mechanism the same results are achieved. So, the mechanism could move corresponding to things movements. At the other experiment it was used on body. To do that schematically it was used on hand. Hand could go up and down but the center of motion was fixed on that.

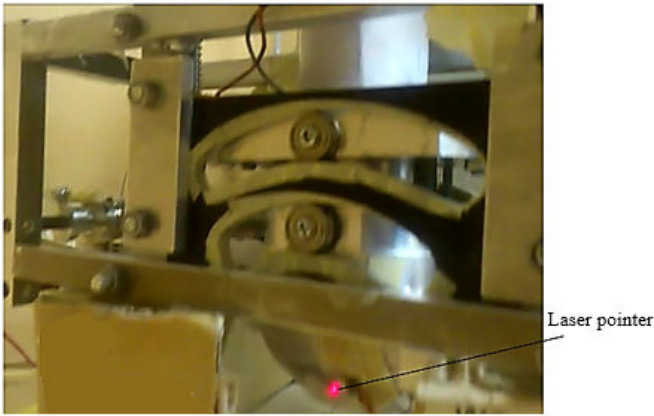

Fig. 5 Laser pointer installed on the tip of probe

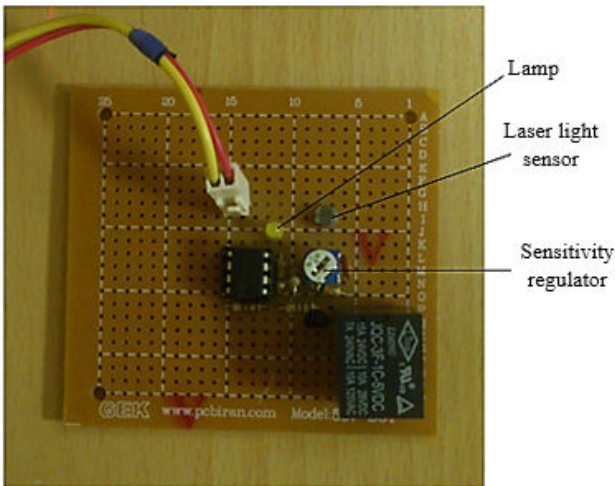

Fig. 6 General view of laser kit

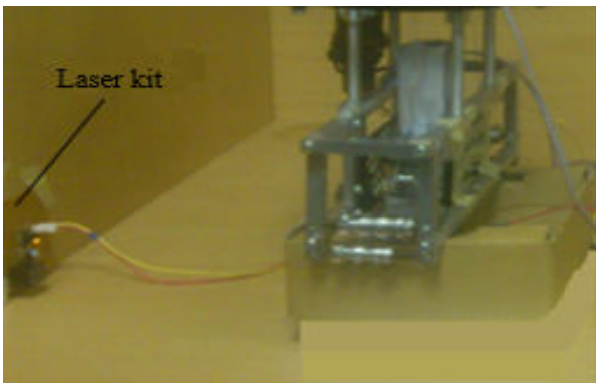

Fig. 7 Experiment set up

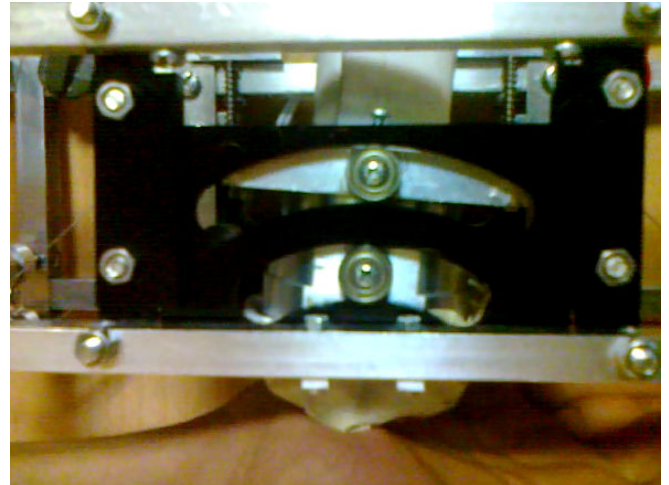

Fig. 8 Keeping the center of motion fixed while hand is down

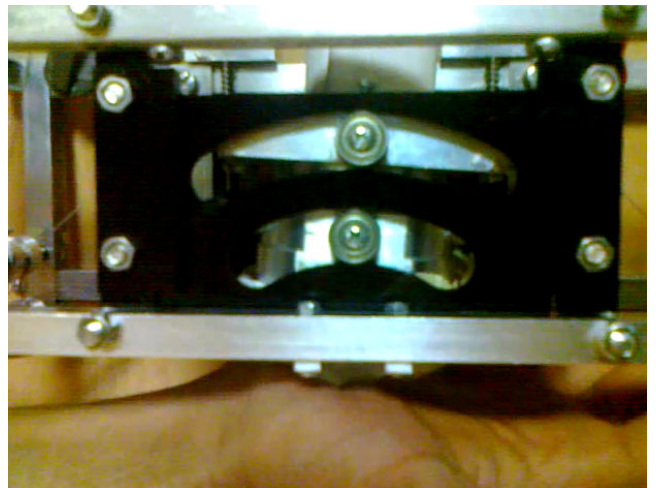

Fig. 9 Keeping the center of motion fixed while hand is up

IV. SIMULATION

The system was simulated in Sam software. Two velocities of cables were connected to the points 1 and 2 and the component movements were observed (Fig. 10). The diagrams of velocity of these two points are bringing below (Figs. 11 and 12).

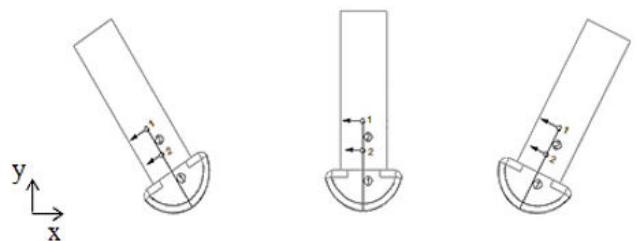

Fig. 10 Observed movements of the component

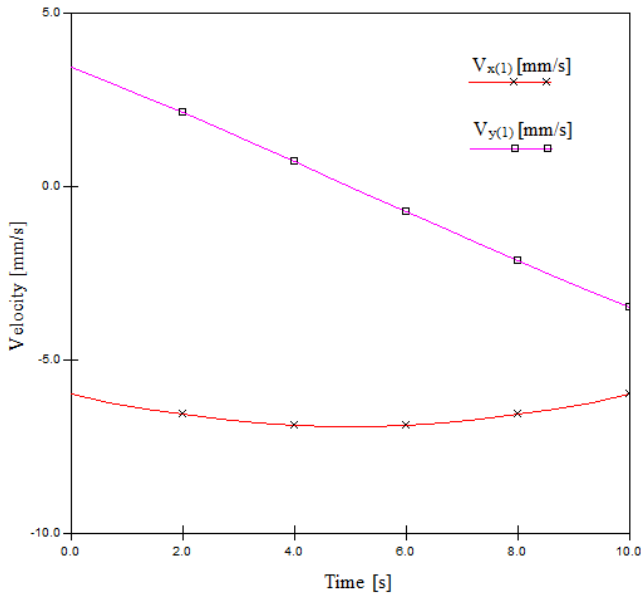

Fig. 11 Horizontal and vertical velocities of point 1

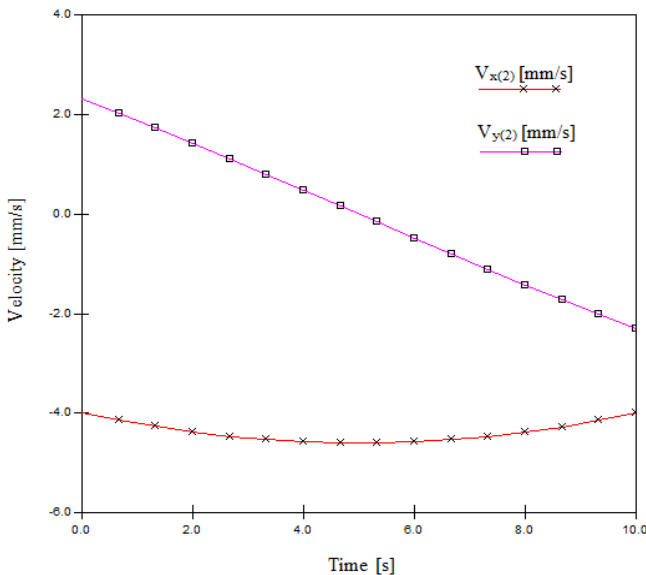

Fig. 12 Horizontal and vertical velocities of point 2

V. CONCLUSION

In this paper a new design for creating variable center of motion is described. This mechanism was manufactured and two experiments were accomplished on that. One experiment shows that the laser pointer installed on the tip of the rotary part of the robot could send light to the fixed lamp all of the time. So, this laser pointer is in the center of motion of the part which is a very great result. After that the rotary part and velocities of two points of it which is connected to cables were simulated, their movements observed and their diagrams were extracted. Another is for center of motion on the moving part of body. So, it could be concluded that it is a good way to create a center of motion for mechanisms.

REFERENCES

- [1] A. Abbasi-Moshaii and F. Najafi, "A review of robotic mechanisms for ultrasound examinations." *Industrial Robot: An International Journal*, vol. 41, pp. 7-7, 2014.
- [2] J. Funda. "Remote center-of-motion robot for surgery." U.S. Patent No. 5,397,323. 14 Mar. 1995.
- [3] R. Baumann, "The pantoscope: A spherical remote-center-of-motion parallel manipulator for force reflection." In *Proceedings, IEEE International Conference on Robotics and Automation*, Vol. 1. IEEE, 1997.
- [4] T. Salcudean, W. Zhu, P. Abolmaesumi, S. Bachmann, and P. Lawrence, "A robot system for medical ultrasound," in *Robotics Research-International Symposium-*, 2000, pp. 195-202.
- [5] M. Mitsuishi, S. i. Warisawa, T. Tsuda, T. Higuchi, N. Koizumi, H. Hashizume, et al., "Remote ultrasound diagnostic system," in *Robotics and Automation, 2001. Proceedings 2001 ICRA. IEEE International Conference on*, 2001, pp. 1567-1574.
- [6] N. Koizumi, S. I. Warisawa, M. Mitsuishi, and H. Hashizume, "Continuous path controller of slave manipulator in remote ultrasound diagnostic system," in *Proceedings, ICRA'02. IEEE International Conference on Robotics and Automation, 2002*, pp. 3368-3373.
- [7] A. Vilchis, J. Troccaz, P. Cinquin, K. Masuda, and F. Pellissier, "A new robot architecture for tele-echography," In *Proceeding, IEEE Transactions on Robotics and Automation*, vol. 19, pp. 922-926, 2003.
- [8] C. Delgorgue, F. Courrèges, L. A. Bassit, C. Novales, C. Rosenberger, N. Smith-Guerin, et al., "A tele-operated mobile ultrasound scanner using a light-weight robot," In *Proceeding, IEEE Transactions on Information Technology in Biomedicine*, vol. 9, pp. 50-58, 2005.
- [9] R. H. Taylor and D. Stoianovici, "Medical robotics in computer-integrated surgery," In *Proceeding, IEEE Transactions on Robotics and Automation*, vol. 19, pp. 765-781, 2003.
- [10] A. Vilchis-González, J. Avila-Vilchis, and A. García-Torres, "TERMI robot," In *Proceedings of the Electronics, Robotics and Automotive Mechanics Conference, 2007*, pp. 464-469.
- [11] F. Najafi and N. Sepehri, "A robotic wrist for remote ultrasound imaging." *Mechanism and Machine Theory*, vol. 46, pp. 1153-1170, 2011.
- [12] K. Ito, S. Sugano, and H. Iwata, "Wearable echography robot for trauma patient," In *Proceeding, (IROS), 2010 IEEE/RSJ International Conference on Intelligent Robots and Systems, 2010*, pp. 4794-4799.