

Contrast Enhancement of Masses in Mammograms Using Multiscale Morphology

Amit Kamra, V. K. Jain, Pragya

Abstract—Mammography is widely used technique for breast cancer screening. There are various other techniques for breast cancer screening but mammography is the most reliable and effective technique. The images obtained through mammography are of low contrast which causes problem for the radiologists to interpret. Hence, a high quality image is mandatory for the processing of the image for extracting any kind of information from it. Many contrast enhancement algorithms have been developed over the years. In the present work, an efficient morphology based technique is proposed for contrast enhancement of masses in mammographic images. The proposed method is based on Multiscale Morphology and it takes into consideration the scale of the structuring element. The proposed method is compared with other state-of-the-art techniques. The experimental results show that the proposed method is better both qualitatively and quantitatively than the other standard contrast enhancement techniques.

Keywords—Enhancement, mammography, multi-scale, mathematical morphology.

I. INTRODUCTION

BREAST cancer is the most fatal disease found among women after cervical cancer in India [1]-[2]. Large numbers of deaths are encountered every year due to this disease.

The actual cause of breast cancer is yet not identified thus the only viable solution is its early prevention. Mammography is the one of the most technically demanding procedure of retrieving an image of the breast in order to determine the presence or absence of any abnormality. Its functioning depends on absorption of X-rays by the different elements of the breast that comprises of fats [3]. The abnormality considered in the present work is masses. Masses are the bright regions with size ranging from 3 to 30 mm. Masses show the attributes of spicules which are compatible with linear features radiating from breast tissues [4].

Masses have complicated structured backgrounds. Thus small diagnostic features need to be highlighted while processing the image that is superimposed on a complex background. In the current study, the enhancement of masses has been done using multi-scale morphology. Multiscale Morphology is a novel technique of retrieving various components based on structuring element which can have different shapes. The masses in mammogram under consideration usually have different shapes;

thus, the components from image are able to represent, describe boundaries, shapes, skeletons, etc. The technique of mathematical morphology formulated by G. Matheron and J. Serra in 1964 [5]. Morphological methods generally include exploring of complete image by a structuring element and at each coordinates the structuring element performs some operation with the neighboring elements.

The sets are defined in mathematics as combination of related elements and in a similar manner mathematical morphology sets are defined as objects. This set is either the full image or part of image and other set is the structuring element. The fundamental morphological operations are erosion and dilation. The erosion of a grey scale image $I(x,y)$ by a structuring element $Se(i,j)$ is defined by (1)

$$(I \ominus Se)(m, n) = \min\{I(m-i, n-j) + Se(i, j)\} \quad (1)$$

The gray scale dilation can be described as by (2):

$$(I \otimes Se)(m, n) = \max\{I(m+i, n+j) - Se(i, j)\} \quad (2)$$

The opening operation of image, using the structuring elements Se , is defined as erosion which is followed by dilation and again using the structuring element Se , the closing operation of image is defined as dilation which is followed by erosion and given by (3) and (4) respectively:

$$(I \circ nSe)(m, n) = ((I \otimes nSe) \ominus nSe)(m, n) \quad (3)$$

$$(I \bullet nSe)(m, n) = ((I \oplus nSe) \otimes nSe)(m, n) \quad (4)$$

There are two versions of mathematical morphology, one is the white top-hat and the other is black top-hat. The top-hat transformation relies on the fact that brighter areas can be removed from the image by gray scale opening i.e. the features that cannot hold the structuring element; same is true for closing operation also.

That means using a closing operation instead of an opening and subtracting the original image from the closed one helps to extract dark features from a brighter background. Thus, white top-hat is used to extract white image regions and bottom top-hat is used to extract black image regions. These are described as given in (5) and (6), respectively:

$$Fwth = ((I - (I \circ Se))(m, n)) \quad (5)$$

$$Fbth = ((I \bullet Se) - I)(m, n) \quad (6)$$

Amit Kamra is with the Guru Nanak Dev Engineering College, Ludhiana, Punjab, 141006 India (Phone: +91-9814229753; fax: 0161-2502700; e-mail: amit_malout@yahoo.com).

V K Jain is a professor in Department of Instrumentation Engineering at SLIET University Longowal, Sangrur, Punjab, 148001 India (e-mail: vkjain27@yahoo.com).

Pragya is working at MNC in Delhi 11002 India (e-mail: pragyabenajeer@gmail.com).

where $I(m, n)$ is a gray scale image, Se is the structuring element used and $Fwth$ represents white top hat regions and $Fbth$ black top hat regions.

II. RELATED WORKS

Stojic et al. [6] has proposed an algorithm for both local contrast enhancement and background texture suppression in digital mammographic images using mathematical morphology. Mini MIAS database is used for experimentation. The outcome is fast and appropriate for real time mammogram processing as it enhances the light details.

Kamra et al. [7] presented a method for enhancement of subtle signs using multi scale morphology. The authors used samples from MIAS database for testing. Quantitative analysis was done using background and detail variance.

Mohanta et al. [8] proposed a method based upon the adaptive region growing technique for x-ray images. This involves the implementation of 8-connected approach and concept of seed selection. The images used were low contrast X-Ray of bone-xray-ankl and chest images. The derived results are giving better values to Proposed Enhancement method followed by zooming and edge growing.

Kimori et al. [9] proposed a method that was implemented on medical images for the enhancement of structural features using rotational morphological processing. The database used is Mini MIAS. The proposed method gives higher CIR values of test images than other methods.

Bai et al. [10] enhanced the image through extending the contrast difference between the extracted white and black image regions by using multi scale top hat transform. The database used is from Dr. Yan Li at Peking University, Beijing, China, provided the original images.

Mukhopadhyaya et al. [11] presented a scheme for enhancing local contrast of raw images based on multiscale morphology using multi scale top hat transform. The images used were from Set of biomedical images of MRI scan.

The significant local enhancement of the image without appreciable enhancement of noise is attained. Kumar et al. [12] proposed a method that adopted a level dependent threshold for thresholding the detail coefficients of wavelet transform using modified mathematical morphology and biorthogonal wavelet transform. The images used were from MIAS. The CII and EPI values of the proposed algorithm are better than the conventional methods.

Though the above methods have produced significant results yet there is always some scope for improvement.

III. PROPOSED TECHNIQUE

The input images from mini MIAS database are of 1028 by 1028 pixels [13]. The region of interest (ROI) extraction is done through centre each time considering the radius of the masses. The proposed technique as shown in Fig. 1 has been implemented with masses in mammograms where a multi-scale image features is obtained and subsequently these are iterated to obtain the final result. Additional background suppression is also done at the end.

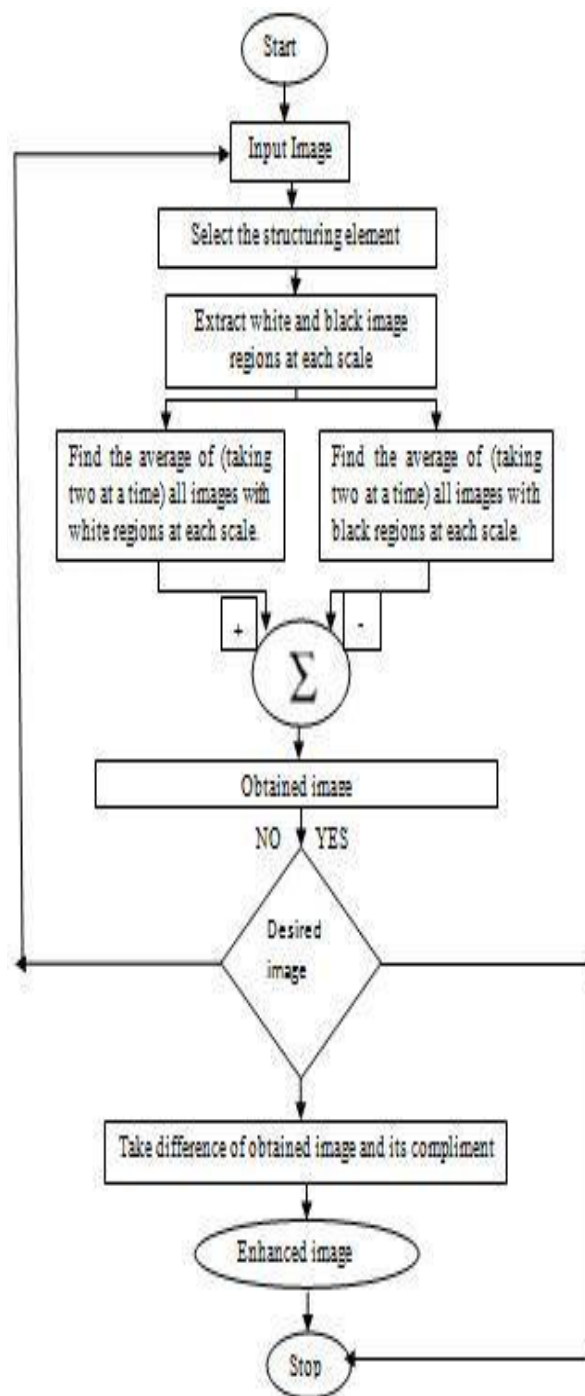

Fig. 1 Flow chart of Proposed Technique

Although the entire machine learning techniques depend on the quantitative estimates of anticipated image enhancement, but the outcome can be further validated by determining certain quality measures. The aim of objective measurement is to define certain metrics that measure those qualities of image enhancement. In the present study, two metrics proposed by MSE and PSNR are used for quantitative evaluation. SNR is the ratio between the utmost probable power of a signal as well as corrupting noise's power that affects the constancy of its expression. To measure the subjective quality of

reconstructed image, the value of PSNR should be high for good quality images while value of MSE should be low for enhanced images.

IV. RESULTS AND DISCUSSION

The proposed algorithm is applied to a set of mammographic images to see the qualitative as well as quantitative performance of the proposed algorithm. In Histogram Equalization (HE), the global contrast of an image is usually increased. As histogram equalization distributes the pixel's intensities equally throughout the image it leads to increase in contrast uniformly. The aim of Histogram Equalization is to render the output image in such a way that gray values in output image get distributed uniformly. Although, this technique is fairly straightforward technique but it can still produce undesirable effects in certain cases like enhancement of background as well as foreground that can further lead to false negatives. In Fig. 2, it can be clearly seen that the details of white region is done. The quantitative results are better for certain test images but if visually analyzed the effects are not satisfactory. Single scale morphology enhances the contrast of the image at a single scale/size of the SE. The enhancement of mammograms is a very delicate task, which requires improvement of contrast that prevents any changes to visual acuity. It must be kept in mind that very little enhancement may prevent detection of masses while over enhancement may substantially increase the magnitude of noise leading to a large number of false positives. In comparison to other methods, the outcome of the proposed algorithm is better for clinical applications. The results of multi-scale morphology are better as compared to the single scale morphology. The results of Stojic's Method (SM) [6] are satisfactory but there are still some features/regions of the image which could be enhanced further as it has used single scale structuring element. Using the Proposed Multi-scale Method, all the features or objects in the image clearly stand out. Thus, this method gives best visual results in comparison with different conventional techniques. The comparative analysis for Mean Square Error (MSE) and Signal to Noise Ratio (SNR) is illustrated in Table I.

TABLE I
 COMPARISON OF PROPOSED METHOD WITH EXISTING TECHNIQUES

Sample	HE		Single scale		SM		Proposed	
	MSE	SNR	MSE	SNR	MSE	SNR	MSE	SNR
mdb002	34.67	17.32	7.34	30.81	5.72	32.96	4.08	35.91
mdb012	28.99	18.88	4.51	35.02	4.68	34.71	2.88	38.91
mdb115	7.70	30.86	4.69	34.70	3.82	36.46	2.65	39.63
mdb117	28.85	19.87	9.21	28.84	5.28	33.67	3.93	36.22
mdb121	42.60	15.54	4.63	34.81	3.29	37.77	2.17	41.36
mdb125	17.70	23.16	7.00	31.22	4.36	35.33	3.27	37.82
mdb171	4.81	34.47	3.26	37.85	2.87	38.94	2.01	42.04
mdb178	36.48	16.88	6.18	32.30	4.36	35.33	2.95	38.72
mdb181	48.98	14.32	6.65	31.67	4.70	34.67	3.19	38.03

V. CONCLUSIONS AND FUTURE SCOPE

In almost all image processing applications contrast improvement is a very significant step for pre-processing. The present paper uses morphological processing which has remained to be a powerful approach to image contrast enhancement problems. In this paper, a very simple and efficient image enhancement algorithm has been implemented for contrast enhancement of mammograms using multi-scale morphological image processing. The proposed method is capable of providing specific enhancement of lesion features and can address different morphological attributes by varying size and shape of SE. The superior performance of the proposed method was verified by comparison of MSE and PSNR. The qualitative as well as quantitative results show that the proposed method has an edge over the other state of the art techniques. The algorithm is very fast and simple to compute and highlights even the minute details. In future, the efficacy and usefulness of proposed method can also be applied to other types of medical images.

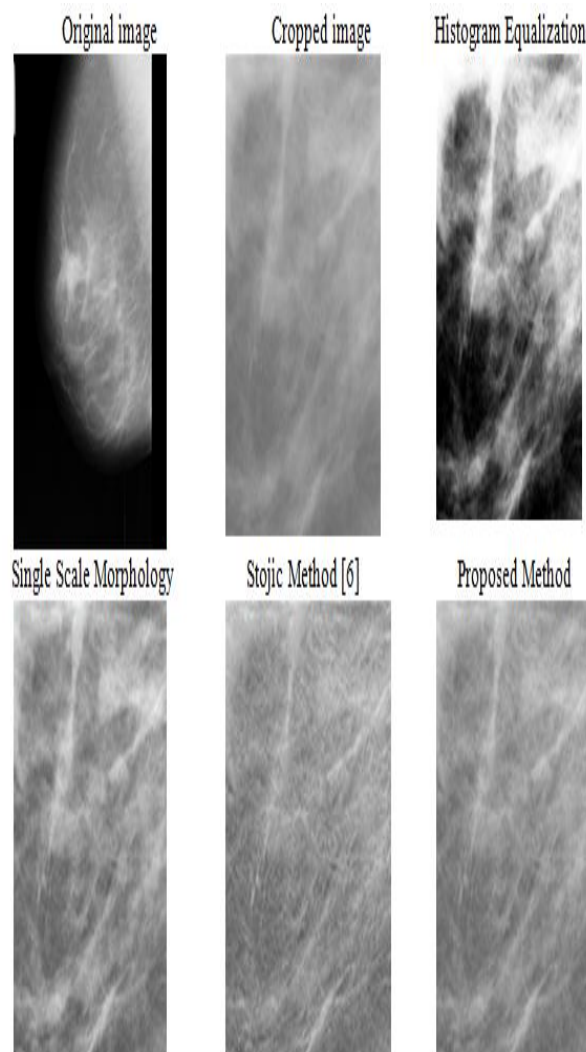

Fig. 2 Enhancement of ROI from 'mdb117.pgm' by various enhancement technique and proposed method

REFERENCES

- [1] Breast Cancer India (Online). Available: <http://www.Breastcancerindia.net>. Accessed 10 Jan 2014.
- [2] Ali I, Wani A.W, Saleem K. 2011. Cancer scenario in India with future perspectives. *Cancer Ther*.8:56-70.
- [3] Rangayyan, R. M. 2005. *The nature of Biomedical Images: Biomedical Image Analysis*. CRC Press, Florida, USA. pp 26.
- [4] American College of Radiology. 2003. (Online). Available: www.Acr.org. Accessed on 25 Dec, 2009.
- [5] Soille, P. 1997. A note on morphological contrast enhancement. *Ecole des Mines d'Alès-EERIE, Tech. Rep*
- [6] Stojic, T., Reljin, I., and Reljin, B. (2005), Local contrast enhancement in digital mammography by using mathematical morphology, *International Symposium on Signals Circuits and Systems, IEEE, Vol. 2, Issue 1, pp.609-612*.
- [7] Kamra A, Jain VK. (2013). Enhancement of subtle signs using multiscale morphological approach. *Proceedings of IEEE Conference on Point of Health Care Technologies, Engineering in Medicine and Biology, Bangalore, India. 16-18 Jan, 2013, pp: 54-57*.
- [8] Mohanta, K., and Khanaa, V. (2013), An Efficient Contrast Enhancement of Medical X-Ray Images –Adaptive Region Growing Approach, *International Journal of Engineering And Computer Science, Vol. 2, Issue 2, pp. 386-390*.
- [9] Kimori, Y. (2011), Mathematical morphology-based approach to the enhancement of morphological features in medical images, *Journal of clinical bioinformatics, Vol. 1, Issue 1, pp.33-40*.
- [10] Bai, X. and Zhou, F. (2010), Multi Scale Top-hat Transform Based Algorithm for Image Enhancement, *International Conference on Image and Signal Processing, Beijing, IEEE, pp.797-800*.
- [11] Mukhopadhyay, S., and Chanda, B. (2000), A multiscale morphological approach to local contrast enhancement, *Elsevier, Signal Processing, Vol. 80, Issue 4, pp.685-696*.
- [12] Kumar, N. H., Amutha, S., Babu, R. (2012), Enhancement of Mammographic Images using Morphology and Wavelet Transform, *International Journal of Computer Technology & Applications, Vol. 3, Issue 1, pp.192-198*.
- [13] Suckling J, Boggis C.R.M, Hutt, I. 1994. *MIAS Proc. of the 2nd Int. Workshop on Mammography, York, England, 10-12 July.1069:375-378*.



Amit Kamra has completed his Ph.D. from SLIET University Longowal, Sangrur, India. He received his master's degrees in Information Technology from Punjabi University, Patiala. He is presently working as Assistant Professor in IT department at GNDEC Ludhiana. His areas of interests are Biomedical Imaging, Breast Cancer detection, Biometrics and CAD.



VK Jain is working as Director and Professor at SLIET University Longowal, Sangrur, Punjab, India. He has done his PhD from Kurukshetra University, Kurukshetra, India. He has published many papers in leading conferences and Journals.



Pragya has done her B.Tech from Uttar Pradesh technical university, Lucknow in 2012. M.Tech from GNDEC, Ludhiana in 2014. She is working as software Engineer in MNC.