

Plasma Chemical Gasification of Solid Fuel with Mineral Mass Processing

V. E. Messerle, O. A. Lavrichshev, A. B. Ustimenko

Abstract—The article presents a plasma chemical technology for processing solid fuels, using examples of bituminous and brown coals. Thermodynamic and experimental investigation of the technology was made. The technology allows producing synthesis gas from the coal organic mass and valuable components (technical silicon, ferrosilicon, aluminum, and carbon silicon, as well as microelements of rare metals, such as uranium, molybdenum, vanadium, etc.) from the mineral mass. The thusly produced high-calorific synthesis gas can be used for synthesis of methanol, as a high-calorific reducing gas instead of blast-furnace coke as well as power gas for thermal power plants.

Keywords—Gasification, mineral mass, organic mass, plasma, processing, solid fuel, synthesis gas, valuable components.

I. INTRODUCTION

CURRENTLY and in the foreseeable future (up to 2100), the global economy is oriented to the use of organic fuel, mostly, solid fuels, the share of which constitutes 40% in the generation of electric power and 24% in the generation of heat power. Therefore, the development of technologies for their effective and environmentally clean application represents a priority problem nowadays [1]-[7]. This work presents the results of long-term investigations of plasma resource- and power-saving technology for comprehensive processing of solid fuels (gasification of solid fuel with simultaneous mineral mass processing) [8]-[11]. The use of this technology for producing target products (synthesis gas, hydrogen, technical carbon, and valuable components of mineral mass of different coals) meets the modern environmental and economic requirements applied to basic industrial sectors. In environmental terms, the comprehensive plasma technology of coal processing for the production of synthesis gas from the coal organic mass (COM) and valuable components from coal mineral mass (CMM) is highly promising. The essence of this technology is heating the coal dust by oxidizing electric arc plasma to the temperature of its complete gasification, turning COM into environmentally clean fuel, a synthesis gas, free from particles of ash, nitrogen oxides, and sulfur. At the same time, CMM oxides are reduced by the carbon residue,

generating valuable components, such as technical silicon, ferrosilicon, aluminum, and carbon silicon, as well as microelements of rare metals, such as uranium, molybdenum, vanadium, etc. [11]. CMM, free from carbon, can be used for the production of refractory and abrasion-resistant materials, mineral fibers, stone casting, and siliceous blocks.

II. THERMODYNAMIC ANALYSIS

Analysis can be made using a versatile thermodynamic computation program TERRA [7]. Figs. 1–4 show a typical equilibrium composition of gaseous and condensed phases in comprehensive plasma processing of Ekibastuz bituminous coal with the ash content of 40% and the heating value 16,632 kJ/kg. The mixture composition is: 100 kg of coal + 40.25 kg of steam. The gaseous phase (Fig. 1) of comprehensive coal processing products includes, basically, a synthesis gas with a concentration of up to 99 vol.% at 1500 K. The total concentration of atomic and molecular hydrogen, varying from 40% to 59%, exceeds the CO concentration in the entire temperature range. With increasing temperature, the concentration of carbon monoxide decreases from 47% at 1500 K to 34% at 4000 K. A great share of CMM components converts from the condensed phase (Fig. 3) to the gaseous and condensed phase (Fig. 2) at a temperature above 1500 K, turning completely into the gaseous phase at a temperature above 2600 K (Fig. 3). At temperatures above 3000 K, the gaseous phase includes, basically, Si, Al, Ca, Fe, Na, and compounds of SiO, SiH, AlH, and SiS. The latter compounds dissociate into relevant elements with increasing temperature.

It should be noted that the specific power consumption increases monotonously from 1 kWh/kg at 1000 K to 6.9 kWh/kg at 4000 K.

An important characteristic is the dependence of the coal carbon gasification rate on the process temperature (Fig. 4). It can be seen from Fig. 4 that the rate of gasification during comprehensive coal processing in the steam plasma reaches 100% at temperatures above 1800 K. In the temperature range of 1300–1700 K the gasification growth slows down. This is related to the fact that, actually, all steam introduced into the system is used up and no oxygen, required for gasification of the residual solid carbon, remains in the gaseous phase. With increasing temperature, the processes of conversion of the mineral coal components begin. As a result, the gaseous phase includes oxygen the quantity of which is sufficient to complete the carbon gasification process.

V. E. Messerle is with Research Institute of Experimental and Theoretical Physics of Kazakhstan National University, Almaty, Kazakhstan, and Institute of Thermophysics of SB RAS, Novosibirsk, Russia (e-mail: ust@physics.kz).

O. A. Lavrichshev is with Research Institute of Experimental and Theoretical Physics of Kazakhstan National University, Almaty, Kazakhstan (e-mail: lavr@physics.kz).

A. B. Ustimenko is with Research Department Plasmotechnics Ltd. and Research Institute of Experimental and Theoretical Physics of Kazakhstan National University, Almaty, Kazakhstan (phone: 7727-377-3369; fax: 7727-377-3174; e-mail: ust@physics.kz).

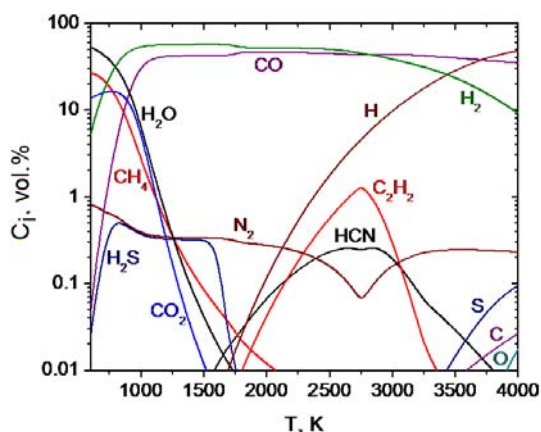

Fig. 1 Temperature dependence of the organic component concentration in the gaseous phase during comprehensive coal processing

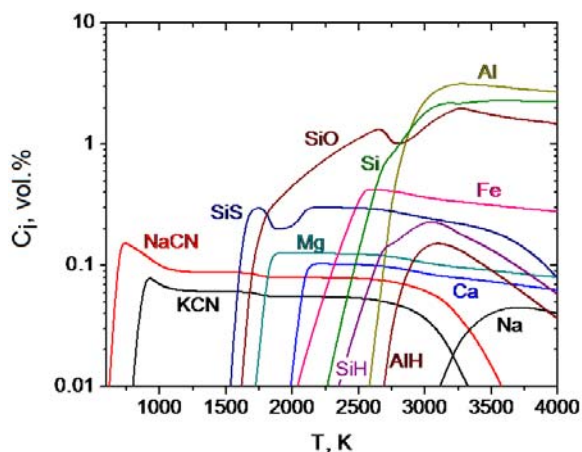
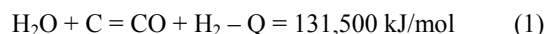
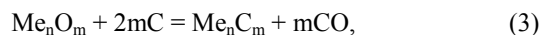

Fig. 2 Temperature dependence of the mineral component concentration in the gaseous phase during comprehensive coal processing

In environmental terms, the comprehensive plasma coal processing technology is the most promising. Its essence is heating the coal dust by reducing electric arc plasma to the complete gasification temperature, when the coal organic mass converts into environmentally clean fuel, i.e., synthesis gas, free from particles of ash, nitrogen oxides and sulfur. At the same time, oxides of the coal mineral mass are reduced by the carbon residue, producing valuable components, such as technical silicon, ferrosilicon, aluminum and carbon silicon, as well as microelements of rare metals, such as uranium, molybdenum, vanadium, etc. In comprehensive plasma coal processing, the endothermic effect of the carbon gasification reaction by water steam



is completely compensated by the electric arc plasma power. Oxides of the CMM are reduced to metals and metalloids via the following reactions:



where Me is the metal or metalloid in the CMM, and n and m are the stoichiometric coefficients of the reactions.

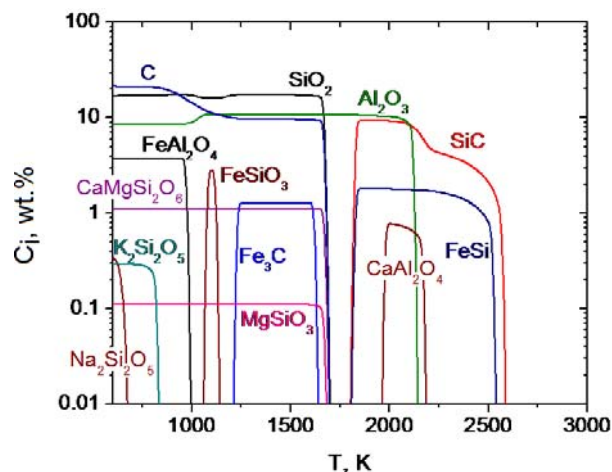

Fig. 3 Temperature dependence of the component concentrations in the condensed phase during comprehensive coal processing

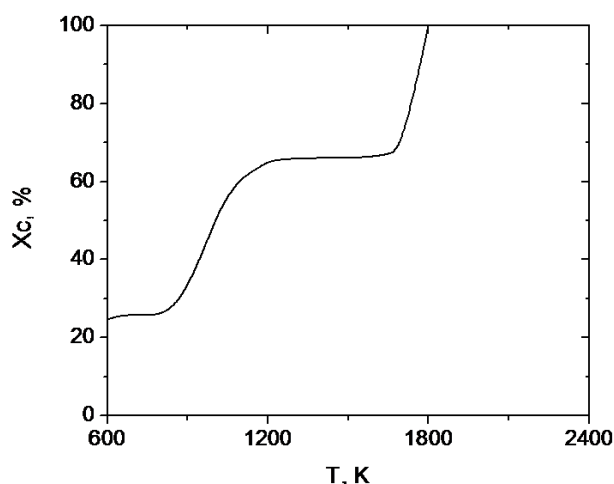

Fig. 4 Temperature dependence of coal gasification during its comprehensive processing

As a result of reaction (1), the coal organic mass converts to a synthesis gas, while the coal mineral mass turns to valuable components via reactions (2) and (3).

III. EXPERIMENT

Comprehensive plasma processing of coals to produce synthesis gas and valuable components from the coal mineral mass was investigated by using a versatile experimental unit, represented schematically in Fig. 5.

Fig. 6 shows a photo of the experimental unit. The plasma reactor (Fig. 5) has additional holes for connecting pyrometric equipment and measuring temperatures in the reaction area. Fig. 7 shows a photo of the plasma chemical reaction in operation.

The specialized plasma reactor for comprehensive coal processing can be used for thermal coal processing, producing synthesis gas ($\text{CO} + \text{H}_2$) from the fuel organic part and valuable components (SiC , FeSi , etc.) from the coal mineral mass. This experimental unit is designed to operate in the power range from 40 to 120 kW, the mean mass temperature of 1800–3000 K, the milled coal flow rate 3–10 kg/h, and a gaseous reagents flow rate of 0.5–10 kg/h.

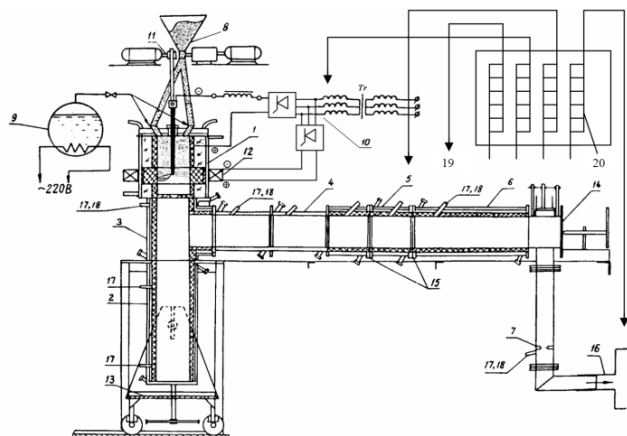

Fig. 5 Schematic of the experimental unit for plasma processing of solid fuel: 1 – DC plasma reactor; 2 – slag collector; 3 – synthesis gas and slag separating chamber; 4, 5, 6 – synthesis gas reducing and cooling chambers; 7 – orifice meter; 8 – coal dust feeding system; 9 – steam and gas generation and feeding systems; 10 – electrical supply system; 11 – electrode feeding system; 12 – electromagnetic coil; 13 – lifting trolley; 14 – flue gas exhaust section with a safety valve; 15 – desulfurization sections; 16 – ventilation system; 17 – thermocouple input pipes; 18 – gas sampling pipes; *Tr* – transformer; 19 – system for cooling the unit assemblies; 20 – rotameters

The material and heat balance data were used to find the process integrated indicators. Table I presents the typical results of the plasma and steam comprehensive processing of low-grade Turgai brown coal with an ash content of 28% and the calorific value 13,180 kJ/kg. The synthesis gas yield was 95.2%, the carbon gasification rate was 92.3%, and the coal desulfurization rate was 95.2%.

TABLE I
 INTEGRATED CHARACTERISTICS OF THE COMPREHENSIVE PLASMA
 PROCESSING OF TURGAI BROWN COAL

T, K	Q_{spec} , kW·h/kg	CO H ₂		X_C , %	X_S , %
		Volume %			
3100	5.36	45.8	49.4	92.3	95.2

The reduction of solid residue samples from different unit assemblies for plasma chemical fuel processing and the special melt bath near the graphite diagram, located at the output of reactor 1 (Fig. 5), is presented in Table II. It can be seen from the table that the reduced material was found in the slag in the form of ferrosilicon, silicon carbide, and iron. The maximum oxide reduction rate in the coal mineral mass was observed in the slag from the walls of the reactor electric arc chamber in the area of maximum temperatures reaching 47%.



Fig. 6 The photo of the experimental unit for coal processing

TABLE II
 THE REDUCTION RATE (Θ) OF THE COAL MINERAL MASS

Sampling place	T, K	Θ , %
Slag from the melt bath	2600-2800	8.5-44.0
Slag from the electric arc chamber walls	2600-2900	16.5-47.3
Material of the slag collector	2000-2200	6.7-8.3

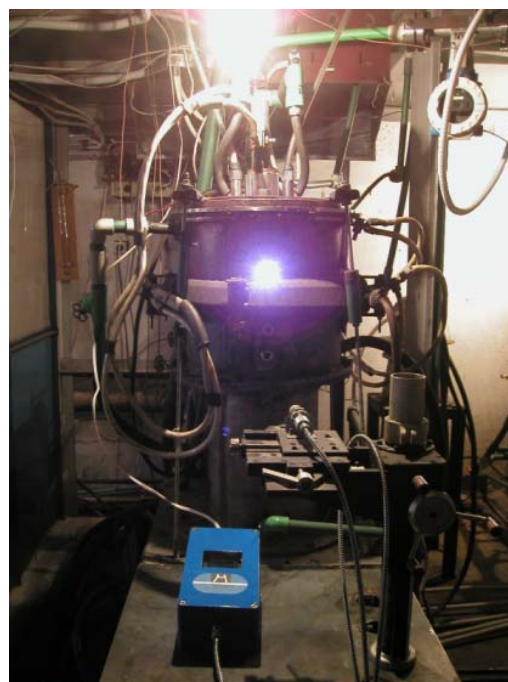

Fig. 7 The plasma chemical reactor in operation

IV. CONCLUSION

The range of theoretical calculations and experimental investigations demonstrated that during comprehensive plasma processing of solid fuel its organic mass converts to synthesis gas, while its mineral mass to a range of valuable components. The high-calorific value synthesis gas, produced by this process, can be used for synthesis of methanol, or as high-potential reducing gas instead of blast-furnace coke, as well as for power generation at thermal power plants.

ACKNOWLEDGMENT

This work was supported by Ministry of Education and Science of the Republic of Kazakhstan and Ministry of Education and Science of the Russian Federation (Agreement on grant No. 14.613.21.0005, project RFMEFI61314X0005).

REFERENCES

- [1] S. I. Serbin, I. B. Matveev, "Theoretical Investigations of the Working Processes in a Plasma Coal Gasification System", *IEEE Trans. Plasma Sci.*, vol. 38, no. 12, pp. 3300–3305, 2010.
- [2] I. B. Matveev, S. I. Serbin, "Theoretical and Experimental Investigations of the Plasma-Assisted Combustion and Reformation System", *IEEE Trans. Plasma Sci.*, vol. 38, no. 12, pp. 3306–3312, 2010.
- [3] A. S. Askarova, S. A. Bolegenova, I.V. Loktionova, E.I. Lavrishcheva, "Numerical modelling of furnace processes at the combustion of high-ash Ekibastuz coal", *Thermophysics and Aeromechanics*, vol. 9, no. 4, pp. 559–569, 2002.
- [4] Yuchun Zhang, Zhenbo Wang, Youhai Jin. "Simulation and experiment of gas-solid flow field in short contact cyclone reactors", *Chem. Eng. Research and Design*, vol. 91, no. 9, pp. 1768–1776, 2013.
- [5] K. Kumabe, T. Hanaoka, S. Fujimoto, T. Minowa, K. Sakanishi, "Co-gasification of woody biomass and coal with air and steam", *Fuel*, vol. 86, no. 5-6, pp. 684-689, 2007.
- [6] R. Mourao, A. R. Marquesi, A. V. Gorbunov, G. P. Filho, A. A. Halinowski, C. Otani, "Thermochemical Assessment of Gasification Process Efficiency of Biofuels Industry Waste With Different Plasma Oxidants", *IEEE Trans. Plasma Sci.*, DOI:10.1109/TPS.2015.2416129, April 2015.
- [7] P. M. Kanilo, V. I. Kazantsev, N. I. Rasyuk, K. Schunemann, D. M. Vavriv, "Microwave plasma combustion of coal", *Fuel*, vol. 82, pp. 187–193, 2003.
- [8] M. Gorokhovski, E. I. Karpenko, F. C. Lockwood, V. E. Messerle, B.G. Trusov, and A.B. Ustimenko, "Plasma technologies for solid fuels: experiment and theory", *Journal Energy Inst.*, vol.78, no.4, pp. 157–171, 2005.
- [9] E. I. Karpenko, Yu. E. Karpenko, V. E. Messerle, A. B. Ustimenko, "Using Plasma-Fuel Systems at Eurasian Coal-Fired Thermal Power Stations", *Thermal Engineering*, vol.56, no.6, pp. 456-461, 2009.
- [10] V. E. Messerle, E. I. Karpenko, A. B. Ustimenko, "Plasma Assisted Power Coal Combustion in the Furnace of Utility Boiler: Numerical Modelling and Full-Scale Test", *Fuel*, vol.126, pp. 294-300, 2014.
- [11] V. E. Messerle, A. B. Ustimenko, "Plasma technologies for fuel Conversion", *High Temperature Material Processes*. vol.16, no. 2, pp. 97–107, 2012.

Vladimir E. Messerle was born in Alma-Ata, Kazakhstan, on June 10, 1947. In 1970 he graduated from Physical department of Kazakh State University. He has Candidate Degree on physical and mathematical sciences (equivalent to Ph.D.), Moscow, 1979, Doctor Degree on technical sciences, Moscow, 1991, Professor, Moscow, 1997, academician of International Energy Academy, Moscow, 1997, academician of International Informatization Academy, Moscow, 2003. He is Professor of the Chair "Thermal Power Plants" of East-Siberian State Technological University, Ulan-Ude, 1998, and Professor of the Chair of Thermal Physics and Technical Physics of the Physicotechnical Department of Kazakh National University after al-Farabi, 2002. He is a head of the laboratory of Plasma Chemistry of the Combustion

Problems Institute, 2001, and leading staff scientist of Institute of Thermophysics of Russian Academy of Science, Novosibirsk, Russia. Vladimir Messerle is the main author of the technology of electrothermochemical preparation of the solid fuel for burning. Under the direction of Professor Messerle 13 Ph.D. theses and 2 doctoral theses were prepared and defended. From 2011 he is co-chairman of National Scientific Council of the Republic of Kazakhstan on «Energetics and machinery».

Alexander B. Ustimenko was born in Almaty, Kazakhstan, in 1962. He received the Degree from the Department of Physics, Kazakh State University, Almaty, in 1984, Ph.D. in physical and mathematical sciences from Department of Physics, Kazakh State University, Almaty, in 1991, with the thesis on High-Temperature Heating and Gasification of Coal Particles, and Sc.D. in technical sciences from Electro-technical Department with East Siberian State Technological University, Ulan-Ude, Russia, in 2012, with the thesis on Plasma-Fuel Systems for Effectiveness Increase of Solid Fuels Utilization. He was a Researcher with the Kazakh Scientific-Research Institute of Energetics, Almaty, from 1984 to 2001, and a Staff Scientist with the Combustion Problems Institute from 2001 to 2007. He has been the CEO of the Research Department Plasmotechnics, Almaty, since 1992, and a Head of Thermophysics Department of the Research Institute of Experimental and Theoretical Physics, Department of Physics and Techniques, Al-Farabi Kazakh National University, since 2002. From 2014 he is a member of National Scientific Council of the Republic of Kazakhstan on «Energetics and machinery».

Oleg A. Lavrichshev was born in Azerbaydzhan in 1956. He received the Degree from the Department of Physics, Kazakh State University, Almaty, in 1978, Ph.D. in physical and mathematical sciences from Department of Physics, Kazakh State University, Almaty, in 1990. He has been a Director of the Research Institute of Experimental and Theoretical Physics, Al-Farabi Kazakh National University, since 2006.