

Improvement of Voltage Profile of Grid Integrated Wind Distributed Generation by SVC

Fariba Shavakhi Zavareh, Hadi Fotoohabadi, Reza Sedaghati

Abstract—Due to the continuous increment of the load demand, identification of weaker buses, improvement of voltage profile and power losses in the context of the voltage stability problems has become one of the major concerns for the larger, complex, interconnected power systems. The objective of this paper is to review the impact of Flexible AC Transmission System (FACTS) controller in Wind generators connected electrical network for maintaining voltage stability. Wind energy could be the growing renewable energy due to several advantages. The influence of wind generators on power quality is a significant issue; non uniform power production causes variations in system voltage and frequency. Therefore, wind farm requires high reactive power compensation; the advances in high power semiconducting devices have led to the development of FACTS. The FACTS devices such as for example SVC inject reactive power into the system which helps in maintaining a better voltage profile. The performance is evaluated on an IEEE 14 bus system, two wind generators are connected at low voltage buses to meet the increased load demand and SVC devices are integrated at the buses with wind generators to keep voltage stability. Power flows, nodal voltage magnitudes and angles of the power network are obtained by iterative solutions using MIPOWER.

Keywords—Voltage Profile, FACTS Device, SVC, Distributed Generation.

I. INTRODUCTION

THE rapid depletion of fossil fuel resources and the rising public awareness for environmental protection on a worldwide basis have necessitated an urgent search for alternative energy sources. Particularly, one of the various kinds of competitive alternative sources of energy, wind power generation has experienced a very fast development in the entire world. However, wind power may cause problems to the existing grid with regards to power quality. One of the fundamental definitions to power quality problems is any power problem manifested in voltage, current or frequency deviations that results in failure or miss operation of customer equipment. Power quality decrement is generally due to many factors such as impulsive and transients, over voltage or under voltage variations, voltage imbalance, wave distortion, such as dc offset, harmonics, notching and noise, voltage fluctuation and frequency variations.

Voltage stability has been a major concern for power system utilities because of several events of the changes in power systems such as increase in loading, generator reaching

reactive power limits, action of tap changing transformers, load recovery dynamics and line or generator outages. They may cause a progressively and uncontrolled fall of voltages leading to voltage instability or voltage collapse.

The major difficulty associated to the wind energy sources is that in general they don't take part in the services system (adjustment of the voltage, of the frequency, possibility of operation in patrolling the block) whose flow is not easily foreseeable and very fluctuating. The fact of not taking part in the service systems brings to this type of source behaves like passive generators from the electric view point. The penetration rate must then be limited to 20% or 30% of the consumption according to certain experience feedbacks, in order to be able to guarantee the stability of the network under acceptable conditions.

The integration of the wind production unit in the network causes some problems such as the absence of voltage adjustment and the sensitivity of voltage drops. Because the loads and the wind farms output fluctuate during the day, the use of reactive power compensation is ideal for the power system network [1]-[3].

Applied to the electrical networks, the Flexible AC Transmission System (FACTS) devices [4], [5] allow an effective dynamic state as well as a static state of the voltage control in the power transmission and distribution as well as the power quality control, by implementation of the power electronic devices, such as Static Var Compensator (SVC) and static synchronous compensator (STATCOM). Its principal function is to inject reactive power into the system which helps to support the system voltage profile, but it can also be used to reduce the phenomenon of flicker in the presence of fluctuating loads, to moderate the power oscillations and to increase the power transfer and to reduce the hypo-synchronous oscillations, the power system performance has improved. The aim of this paper is to demonstrate the superiority of using FACTS devices to regulate the desired power flow in a power network and to provide the best voltage profile in the system as well as to minimise the system transmission losses when inserting the wind generator in the electrical network.

The Newton-Raphson algorithm [6], [7] is applied in calculation of power systems voltage. The results are obtained for four cases of the network state: without the wind generators and the SVC devices with standard load, without the wind generators and the SVC devices with increased load, with integration of the wind generators and with integration of the SVC devices at the buses where wind generators integrated.

Fariba Shavakhi Zavareh is with the Department of Engineering, Badroud Branch, Islamic Azad University, Badroud, Iran (Corresponding Author: e-mail: shavakhi_f@yahoo.com).

Hadi Fotoohabadi and Reza Sedaghati are with the Department of Electrical Engineering, Darion Branch, Islamic Azad University, Darion, Iran.

II. WIND DISTRIBUTED GENERATION

The major problems of wind are the great variability of its production and especially the difficulty in envisaging this production precisely several hours in advance. The dynamic changes of the wind speed return the quantity of the power injected to a strongly variable network. According to the intensity and rate of change, the difficulties with the frequency and the voltage control could seem making a direct impact on the level of the provided electric power quality [8]-[10]. The problems induced by the integration of wind generators in the electrical network are caused by:

- Their random and not easily foreseeable production;
- An absence of power-frequency adjustment;
- A participation in the voltage adjustment limited for the wind generator to variable speed, and any participation in this adjustment for the wind generators whose generator is directly coupled with the network;
- A high sensitivity of voltage hollows and the variations of frequency for some technologies;
- A significant sensitivity to the fast variations of the wind force.

A. Wind Energy

The principle of kinetic transformation energy of the wind into electric power and the detailed description of the various types of aero-generators are presented in several references. Mechanical power of wind turbine that in fact is a percentage of the total wind energy is calculated as:

$$P = \frac{1}{2} \rho S v^3 C_p(\lambda, \beta) \quad (1)$$

where ρ is the air density, S the surface swept by the turbine, the v wind speed and C_p the power coefficient. This coefficient corresponding to the aerodynamic efficiency of the turbine has a nonlinear evolution according to the tip speed ratio, λ .

$$\lambda = \frac{\Omega_t R_t}{v} \quad (2)$$

where R_t is the blade length and Ω_t is the angular velocity of the turbine.

B. Voltage Stability

The term "power quality" in relation to a wind turbine describes the electrical performance of the wind turbine describes the electrical generating system. The main influences of the wind turbine on the power and voltage quality are voltage changes, fluctuations leading to flicker and harmonics for wind turbines with power electronics. The production units must ensure a control of the voltage and/or reactive power at delivery point [9]-[14]. Three types of primary adjustment are possible: adjustment with constant reactive power, adjustment of the voltage to a value varying linearly according to the power reactive with an adjustable slope and adjustment of the voltage according to an instruction

controlled to the orders coming from the secondary adjustment of the voltage. In both distribution and transmission systems, there is a need to maintain a voltage in the range 0.95-1.05 p.u. Therefore, maintaining acceptable voltage levels in the power system is an important objective. A one line diagram of a power system for the voltage drop analysis is shown in Fig. 1.

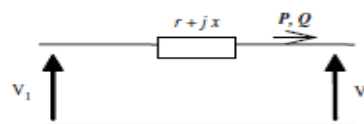

Fig. 1 Simplified equivalent diagram of a line

The voltage drop in line ($\Delta V = V_1 - V_2$) can be writing in an approximate way as [2], [3], [11]:

$$\Delta V = \frac{(rP + xQ)}{V_2} \quad (3)$$

which r and x respectively the resistance and reactance of the line in Ohm, P and Q respectively the active and reactive powers flow on the line. For the high voltage lines ($x \geq 10r$), (3) can thus be simplified:

$$\Delta V = \frac{xQ}{V_2} \quad (4)$$

The active power generated by the wind generators is fluctuate by nature, which tends according to (3) to induce fluctuations of voltage in the zone of the network close to the point of connection of these wind generators. In the transmission network, made up of high voltage lines, (4) shows that the variations of voltage are induced by the reactive power transits contrary with the distribution networks. This is why; it is requested from the wind generators currently connected to the transmission network to take part in the voltage adjustment via an adjustment of the reactive power. This adjustment is possible with the wind generators connected to the network via power electronics.

III. STATIC VAR COMPENSATOR (SVC)

The SVC is a shunt-connected static var generator or absorber whose output is adjusted to exchange capacitive or inductive current so as to maintain or control the specific parameters of the electrical power system. SVC is a variable susceptance controller. The effective susceptance is varied by varying the firing angle of the thyristor of TCR or switching the TSC (Fig. 2).

SVC is a controllable reactive power source. Early applications of SVC were for load compensation of fast changing loads like arc furnaces, and steel mills for dynamic power factor improvement and load balancing in the three phases. Recently, SVCs and are mainly used as voltage regulators. To solve the power flow problems, the FACTS devices offer an alternative to the traditional means of

regulation. These devices based on the power electronics, make it possible to control the voltage level and/or the power transit in the electrical network lines [12], [13], [15]. The FACTS devices can be used for the control of the active power as well as for that of the reactive power or the voltage.

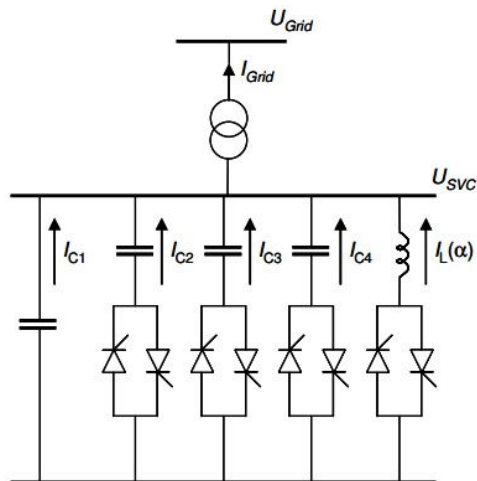

Fig. 2 The SVC principle power diagram

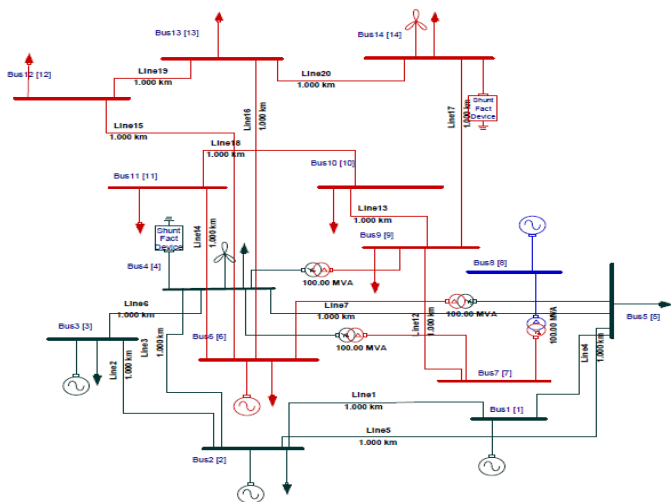

Fig. 3 The proposed 14 bus network structure

To study the impact of the introduction of the SVC device into a network, the Newton-Raphson algorithm is applied in calculation of power systems voltages. Initially, the introduction of the FACTS is carried out, varying the control parameter of the FACTS and by observing the changes on the bus voltages and the transit powers in the lines. The second stage consists in fixing a consign value of (voltage or power) for which the simulation program will find the value of the control size. This way, it will check, if it is possible to regulate a size (voltage or power) to a value consign without deteriorating the static performances of the network

IV. PROPOSED STRATEGY

MiPower is a highly interactive, user-friendly windows based Power System Analysis package. It includes a set of

modules for performing a wide range of power system design and analysis study. MiPower features include a top notch Windows GUI with centralized database. Steady state, transient and electro-magnetic transient analysis can be performed with utmost accuracy and tolerance.

Initially Newton-Raphson algorithm is applied to proposed network without integration of wind generators and SVC devices. From the load flow results, low voltage buses are selected to integrate wind generators. On insertion of wind generators and by conducting load flow results it is seen that the voltages at all PQ buses are increased. It leads to voltage instability in the system, since output of wind generators are fluctuating in nature. To overcome this problem system requires high reactive power compensation, this is achieved by using FACTS devices. SVC devices are integrated at the place where wind generators are integrated and load flow results are obtained. It is seen that the voltages are regulated, to maintain the system stable.

Standard IEEE 14 bus system is used in this paper. Fig. 3 shows the 14 bus test system, where the bus bars are numbered from 1 to 14 and the lines from 1 to 20. The bus bar 1 is the slack bus, buses 2,3,6,8 are P,|V| buses and buses 4,5,7,9,10,11,12,13,14 are P,Q buses. The Newton-Raphson algorithm is applied in calculation of power systems voltages.

V. SIMULATION RESULTS

The results are obtained for four cases of the network state:

- Network without the wind generators and the SVC devices with standard load.
- Network without the wind generators and the SVC devices with increased load.
- Network with integration of the wind generators.
- Network with integration of the wind generators and the SVC.

A. Network without the Wind Generators and the SVC Devices with Standard Load

The bus voltage magnitudes/angles are represented in Table I respectively. From the load flow results and the voltage profiles shown in Table I, it can be seen that bus 4 and bus 14 are low voltage buses. The network state is given in Table I.

TABLE I
WITHOUT WIND GENERATORS AND SVC DEVICES INTEGRATION WITH STANDARD LOAD

Bus	Voltage(p.u.)	Angle(Deg)
1	1.0600	0.00
2	1.0450	-1.94
3	1.0100	-8.46
4	1.0271	-5.12
5	1.0279	-4.14
6	1.0700	-7.95
7	1.0550	-2.25
8	1.0900	4.79
9	1.0427	-5.57
10	1.0404	-6.28
11	1.0519	-7.22
12	1.0536	-8.60
13	1.0488	-8.45
14	1.0271	-7.84

B. Network without the Wind Generators and the SVC Devices with Increased Load

The load demands on the electrical system are continuously increasing. The load demand at the bus 4 and bus 14 are increased to a value where the buses suffer from voltage instability. The bus voltage magnitudes/angles are represented in Table II respectively. From the load flow results and the voltage profiles shown in Table II, it can be seen that a voltage unstable area is formed at bus 4 and bus 14. The network state is given in Table II.

TABLE II
WITHOUT WIND GENERATORS AND SVC DEVICES INTEGRATION WITH INCREASED LOAD

Bus	Voltage(p.u.)	Angle(Deg)
1	1.0600	0.00
2	1.0170	-7.85
3	0.9732	-19.57
4	0.9484	-19.53
5	0.9595	-15.73
6	1.0031	-23.28
7	1.0051	-17.93
8	1.0900	-10.55
9	0.9764	-22.38
10	0.9733	-22.86
11	0.9845	-23.21
12	0.9817	-24.65
13	0.9688	-25.01
14	0.9136	-28.59

C. Network with the Integration of the Wind Generators

The standard 14 bus system, shown in Fig. 3, was modified to incorporate wind generators. The power provided by a wind generator is always variable, due to the wind speed variations. Other side, it is the consumer or the network who must receive a smoothed power and stable voltage. The active power injected by the wind generator P_{wind} inserted into the bus 4 and bus 14 and the Table III shows its influence on the voltages in the other buses. Then according to the results of simulation, the first impact to be observed, it is the reduction in the powers delivered by the generators to network, which flow on the lines, that are relieved by insertion of the aerogenerators, on the other hand, it is the improvement of the voltages at the buses. The network state is given in Table III.

TABLE III
WITH WIND GENERATORS INTEGRATION

Bus	Voltage(p.u.)	Angle(Deg)
1	1.0600	0.00
2	1.0450	-2.14
3	1.0100	-8.94
4	1.0226	-5.77
5	1.0275	-4.38
6	1.0676	-4.00
7	1.0513	0.74
8	1.0900	7.80
9	1.0382	-1.03
10	1.0362	-1.84
11	1.0485	-3.03
12	1.0537	-3.77
13	1.0580	-2.80
14	1.0765	3.50

D. Network with Integration of the Wind Generators and the SVC Devices

Adjustment of the voltage is related to the adjustment of the reactive power injected. The FACTS device which is installed at bus 4 and bus 14 near the wind generators are the shunt device (SVC). This device is most suitable for voltage control and provides reactive support by injecting a reactive power " Q_{shunt} ". The evolution of the voltage magnitudes at buses after injection of the reactive power " Q_{shunt} " at bus 4 and bus 14, place of the integration of the wind generators, and the evolution of the reactive power under to the evolution of the active power delivered by the wind generator.

The goal is to have a stable voltage at buses, no matter what is the variation of the power injected by the wind generator, and that by injecting a reactive power " Q_{shunt} " to compensate the voltage hollows or to fall off the voltage if it exceeds the desired voltage magnitude. The results showed a better behavior with regard to the voltage support on the load bus bars and all the voltage drops within the limits 5%.

Then the voltage instability at the buses is overcome and the voltage at the buses comes to stable condition. The network state on integration of SVC at the point where wind generators are integrated is given in Table IV. The network state is given in Table IV.

TABLE IV
WITH BOTH WIND GENERATORS AND SVC DEVICES INTEGRATION

Bus	Voltage(p.u.)	Angle(Deg)
1	1.0600	0.00
2	1.0450	-2.21
3	1.0100	-9.15
4	1.0017	-5.57
5	1.0098	-4.20
6	1.0234	-3.91
7	1.0261	1.22
8	1.0900	8.45
9	0.9961	-0.67
10	0.9934	-1.56
11	1.0049	-2.85
12	1.0033	-3.59
13	1.0028	-2.32
14	1.0000	5.71

VI. CONCLUSION

Wind energy could be the renewable energy which can be connected in an electrical network to meet the increased load demand. But, the wind production systems are extremely sensitive to the network disturbances. The voltage hollows or the frequency variations involve usually the disconnection of the production during the time of incident on the network. This disconnection can worsen a production/consumption imbalance and consequently accelerate the advent of an important incident in the network. The impacts of the integration of wind generators in an electrical supply network on the voltage stability are presented. The answer of this problem is completed by inserting FACTS devices which would be the SVC devices at the place where wind generators are integrated for the voltage adjustment.

REFERENCES

- [1] S. Schierloch, S. Wachtel, S. Adolff, "Wind farm technology utilizing Wind Energy Converters with FACTS Capabilities", 2009.
- [2] A. Beekmann, J. Marques, E. Quitmann, S. Wachtel, "Wind energy converters with FACTS Capabilities for optimized integration of wind power into transmission and distribution systems", *CIGRE*, 2009.
- [3] H. Ren, D. Watts, Z. Mi, J. Lu "A Review of FACTS" Practical Consideration and Economic Evaluation", *Power and Energy Engineering Conference*, APPEEC, 2009.
- [4] X.-P. Zhang, C. Rehtanz, B. Pal "Flexible AC Transmission Systems: Modelling and Control", *Springer, Berlin*, 2006.
- [5] K. R. Padiyar "FACTS Controllers in Power Transmission and Distribution", *New Age International*, 2007.
- [6] B. Sookananta, S. Galloway, G. M. Burt and J. R. McDonald "The Placement of FACTS Devices in Modern Electrical Network", *UPEC*, 2006.
- [7] E. Acha, V.G. Agelidis, O. Anaya-Lara, T.J.E. Miller "Power Electronics Control in Electrical Systems", *Newnes*, 2002.
- [8] Y.H. Song, A.T. Johns "Flexible AC Transmission Systems (FACTS)", The Institution of Engineering and Technology, 2008.
- [9] T. Gehlhaar, "Grid code compliance beyond LVRT", Bremen, 2009.
- [10] M. Rasmussen, H.K. Jørgensen, "Current Technology for Integrating Wind Farms into Weak Power Grids", *IEEE/PES*, 2005.
- [11] W. Qiao, R.G. Harley "Grid connection Requirements and Solutions for DFIG Wind Turbines", *IEEE Energy 2030*, 2008.
- [12] J. Morren, S.W.H. de Haan, W.L. Kling, J. A. Ferreira, "Wind Turbines Emulating Inertia and Supporting Primary Frequency Control", *IEEE Trans. on Power Systems*, Vol. 21, No. 1, Feb 2006.
- [13] P. Kundur, "Power System Stability and Control", McGraw-Hill.
- [14] C. Wessels, F.W. Fuchs, "Concept and Performance of Voltage Swell Mitigation in Wind farms with FACTS", *EWEC*, 2009.
- [15] W. Qiao, G.K. Venayagamoorthy, R.G. Harley, "Coordinated Reactive Power Control of a Large Wind Farm and a STATCOM Using Heuristic Dynamic Programming", *IEEE Trans. on Energy Conversion*, Vol. 24, No. 2, Jun 2009.