

# A Novel Design in the Use of Planar Transformers for LDMOS Based Amplifiers in Bands II, III, DRM+, DVB-T and DAB+

Antonis Constantinides, Christos Yiallouras

**Abstract**—The coaxial transformer-coupled push-pull circuitry has been used widely in HF and VHF amplifiers for many decades without significant changes in the topology of the transformers. Basic changes over the years concerned the construction and turns ratio of the transformers as has been imposed upon the newer technologies active devices demands. The balun transmission line transformers applied in push-pull amplifiers enable input/output impedance transformation, but are mainly used to convert the balanced output into unbalanced and the input unbalanced into balanced. A simple and affordable alternative solution over the traditional coaxial transformer is the coreless planar balun. A key advantage over the traditional approach lies in the high specifications repeatability; simplifying the amplifier construction requirements as the planar balun constitutes an integrated part of the PCB copper layout. This paper presents the performance analysis of a planar LDMOS MRFE6VP5600 Push-Pull amplifier that enables robust operation in Band III, DVB-T, DVB-T2 standards but functions equally well in Band II, for DRM+ new generation transmitters.

**Keywords**—Amplifier, balun, complex impedance, LDMOS, planar-transformers.

## I. INTRODUCTION

SINCE the innovation of the early stage design in vacuum tube television transmitters, the impedance matching networks have played a key role around the overall performance of the final stage. That is because the output impedance networks are responsible for providing the maximum power transfer between the low impedance of the final stage to the load and vice versa as concerns the input impedance. Thus, it is considered a vital research and development subject around the optimization of new generation transmitters. As the input and output impedance of the final stage, as well as the load are constituted by a real and an imaginary part in order to provide a perfect match, the goal is that the imaginary parts of the two impedances must be cancelled out and their real parts must be equal. In other words the source impedance must be equal to the conjugate impedance of the load as in the example illustrated in Fig 1. In a single ended VHF amplifier the above mentioned was achieved by several popular types of matching networks such as the Pi, L and the RF transformers which later have been applied on solid state amplifiers as is described below:

Antonis Constantinides is with the ET-Broadcast, Limassol, Cyprus (e-mail: etbroadcast@gmail.com).

Christos Yiallouras is with the MEDSONIC LTD, Limassol, Cyprus (e-mail: christosyiallouras@gmail.com).

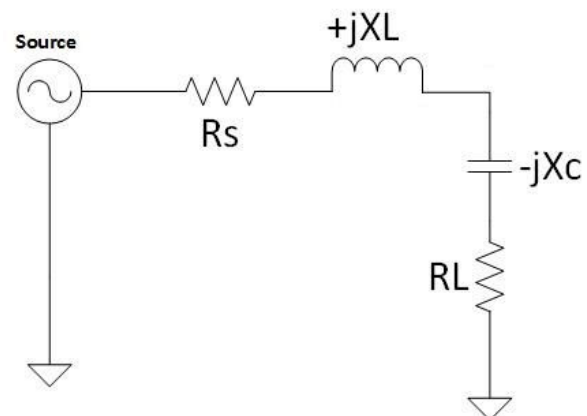

Fig. 1 A typical LC Matching Network

The revolution of solid state technology during the 1960's, forced the industry to optimize impedance matching networks in topologies such as the Doherty [1] and Push-Pull [2] amplifiers. A push-pull amplifier is always constituted by a matched pair of power transistors. The key benefit of

Push-Pull topology is that it doubles the output power of the amplifier without the requirement of splitters and combiners which adds cost and complexity to the design. Furthermore, the input and the output composite impedance of a push pull amplifier presents four times higher value over a single ended device which provide the benefit to having better broadband VSWR response within a specific bandwidth over the single ended device. It also improves the common lead effect as the balun currents are equal in magnitude and opposite in phase. For the aforementioned, it eliminates the even harmonic products, thus also simplifying the complexity of the output filter requirements.

The heart of the coaxial transformer-coupled push-pull circuit topology lies in the transmission line transformers enabling input/output impedance transformation, but mainly to convert the balanced output into unbalanced as well as the unbalanced input into balanced [2]. VHF coaxial type transformers are illustrated in Figs. 2 and 3. The three forms of transformers are defined as the unbalanced-to-unbalanced (unun), balanced-to-balanced (balbal), and balanced-to-unbalanced (balun) [2]. Today, by applying the latest Gemini LDMOS (laterally diffused metal oxide semiconductor) power transistors in push-pull digital DVB-T, DVB-T2 standard amplifiers, we see power output and linearity that was previously unobtainable using bipolar junction transistors or

later type first generation MOSFETS (metal-oxide-semiconductor field-effect transistor) [3]-[5].

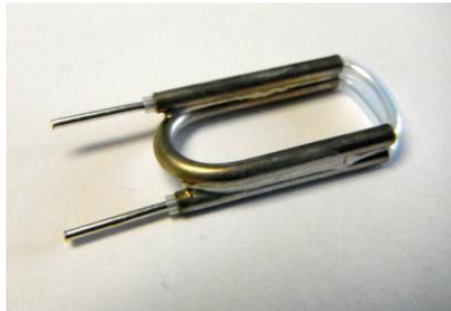

Fig. 2 Turn VHF Coaxial Transformer

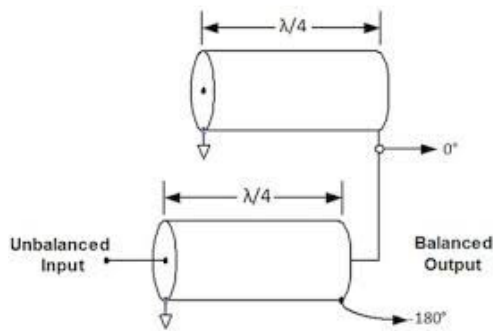

Fig. 3 Coaxial Type Balun

However, the input and output transformers are still constructed by semi rigid coaxial type baluns i.e. as in the earlier generation type amplifiers [6]. Despite coaxial type baluns exhibiting very good temperature stability in high power RF applications and good broadband response, they address a number of major drawbacks that must be optimized in the design of new generation transmitters. For example, the amplifier's production depends on the semi rigid coaxial line's availability in the market. Furthermore, the production cost of the amplifier is increased due to the semi rigid lines' additional cost. Finally, the time consuming requirements to assemble and solder the transformers on the amplifier's PCB adds also to the cost as well as potential production errors [6]. Instead, the planar baluns eliminate all of the above potential production problems. Whether the new generation LDMOS VHF push-pull amplifiers utilized planar technology, will provide to the manufacturers an efficient and affordable solution in terms of production cost and reliability since it constitutes a part of the amplifier's PCB (printed circuit board) copper layout, reducing the manufacturing cost and the assembly errors. LDMOS amplifiers, according to the review study [7], demonstrate that it is a promising technology for further research and improvements in the field. Our research has determined, based on laboratory measurements that the planar LDMOS amplifier provides robust operation in band III DVB-T, DVB-T2 applications but can be used equally well in Band II for DRM+ new generation transmitters. The topology requires almost no components and its analysis is given in the following section.

## II. MATERIAL AND METHODS

The scope of this application is to explore the performance of a planar push-pull amplifier in Bands II and III versus a traditional coaxial transformer, as both designed around the Freescale N-Channel LDMOS MRFE6VP5600 and tested taking into account the recommendations of ETSI TR 101 290 V1.2.1, "Digital Video Broadcasting (DVB); measurement guidelines for DVB systems", (2001- 05). Furthermore, it will determine its useful bandwidth focusing on the low frequency response of the planar baluns. The LDMOS MRFE6VP5600 is illustrated in Fig. 4.



Fig.4 LDMOS MRFE6VP5600

The basic specifications of the MRFE6VP5600 are given in Table I. The two amplifiers under test are illustrated in Fig. 5.

TABLE I  
 TYPICAL PERFORMANCE: VDO = 50 VOLTS, IDO = 100 MA

Signal type	Pout (W)	F (MHz)	Gps (dB)	ηo (%)	IRL (dB)
Pulsed (100 μsec, 20% Duty Cycle)	600 Peak	230	25.0	74.6	-18
CW	600 Avg.	230	24.6	75.2	-17

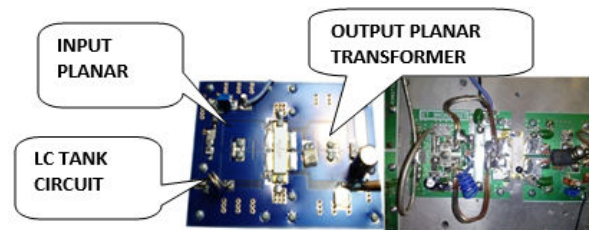

Fig. 5 Planar versus a semi-rigid coaxial type balun amplifier

## III. CONSTRUCTION DETAILS

The design parameters as well as important test results of the MRFE6VP5600 operating as a coaxial transformer-coupled push pull amplifier in the VHF band have been released by [7]. Thus, this chapter demonstrates exclusively the design parameters and the construction details of the planar amplifier as given below:

The dielectric constant, loss tangent, surface resistance and of the PCB material will affect the physical dimensions as well as the performance of the planar balun. Taconic RF-35 double sided PCB has been successfully used by NXP in [8], as it provides the lower dissipation factor 0.0011 at 1.9GHz and allows high power RF performance with low heat generation, thus, it has been adapted in this application as well. According to the dielectric constant of the RF35 substrate, ( $\epsilon_r=3.5$ ), the velocity factor can be then calculated by:

$$VF = \frac{1}{\sqrt{\epsilon_r}} \rightarrow \frac{1}{\sqrt{3.5}} \rightarrow VF = 0.53 \quad (1)$$

For the aforementioned, the physical length of the transformer's secondary windings has been designed equal to a quarter wavelength at the centre frequency of operation i.e. at 220MHz corresponding to 18cm. The primary winding of the transformer has been designed with the highest inductance value possible of 55nH as this equates to a wide edged copper line for good power handling [8]. The calculated value of 55nH was determined to make the winding shunt reactance invisible in relation to the output impedance [9]. Further information on the impedance calculations are given below.

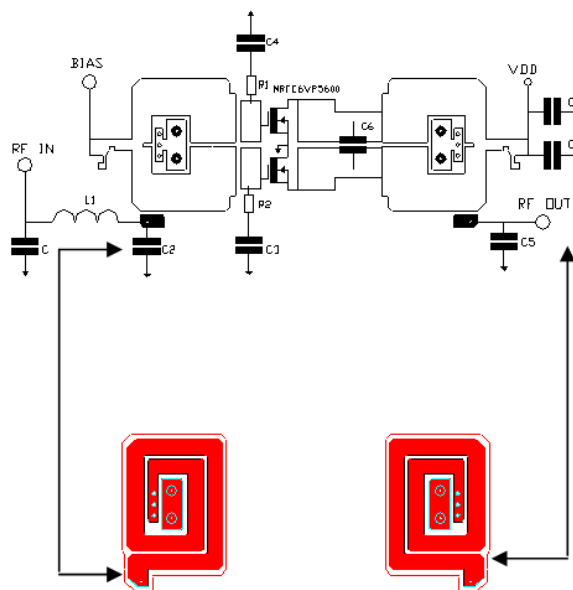

Fig. 6 Planar secondary

A crucial design consideration of the planar amplifier is the input/output impedance ratio. Based on the enclosed data sheet, the input broadband response can be obtained by implementing a 9:1 impedance ratio as the gate to gate complex impedance value of the MRFE6VP5600 at 220MHz is  $Z_{in} = 2*(1.78 + j5.45)$ . Furthermore, an additional LC tank circuit was incorporated in order to improve the input VSWR response to the maximum possible level illustrated in Fig. 6. For better flatness in return loss response across the band, a 50ohm resistor (R1, R2) has been added from each gate of the LDMOS to ground. For the aforementioned, it contributes also for stability purposes i.e. the added resistors reduce the gain of the amplifier at 3dB in order to prevent oscillations. The output planar balun has been designed based on the output impedance value at a frequency of 220 MHz, which is  $Z_{out} = 2*(2.75 - j5.30)$ . Thus, the impedance ratio required at the output port must also be 1:9 that provides the output and the input planar transformers to have the same topology, illustrated in Fig. 6. The major test results of the amplifier are given below:

#### IV. TEST RESULTS

The amplifier has been tested initially between 80-110MHz in order to evaluate its performance applying to the DRM+ digital transmitter standard.

The VSWR response between 80-110 MHz is illustrated in Fig. 7 as this test has been executed for the DRM+ standard. The minimum VSWR ratio was measured at 1.1:1 i.e. corresponding to a perfect match. The maximum VSWR ratio of 1.4:1 was measured at a frequency of 80MHz. A simulation has determined that the average VSWR ratio between 80-110 MHz is only 1.16:1 i.e. corresponding to 22.6 dB of return loss which is a very acceptable value among 30 MHz of operation.

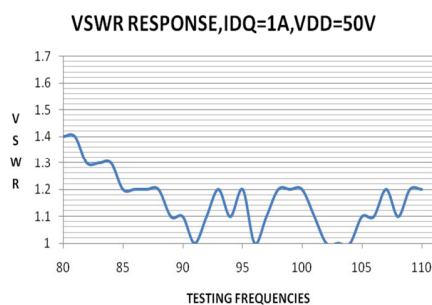

Fig. 7 VSWR Response

The output power of the amplifier in a continuing wave Class-C operation between 80-110MHz is presented in Fig. 7. It has been tested in a non-linear mode as the new DRM+ standard transmitters enable operation by the use of the Envelope Elimination and Restoration (EER) approach.

According to Fig. 8 the minimum power of 450 W has been measured at 80 MHz, and the maximum power of 710 W in the center of the band. Upon simulation, the average CW power between 80-110 MHz is then  $580 W \pm 22\%$  while between 87-108 MHz is  $630 W \pm 12\%$ .

In case of a linear COFDM waveform application the peak to average ratio must be taken into account and is in the order of 12dB below the 1dB compression point of the amplifier.

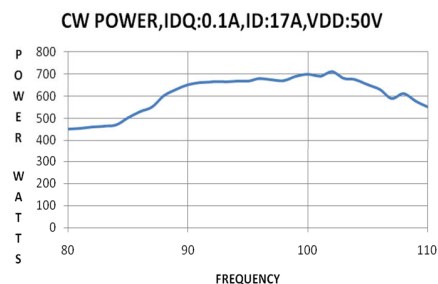

Fig. 8 CW Power

The input return loss in band III (174-240) is illustrated in Fig. 9.

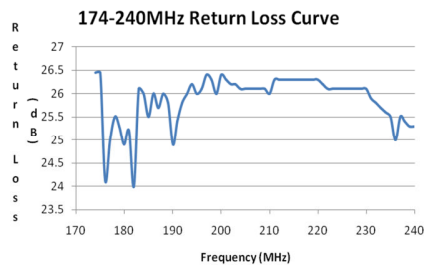

Fig. 9 Return Loss Curve  
AVG.DVB-T POWER OUTPUT BAND III

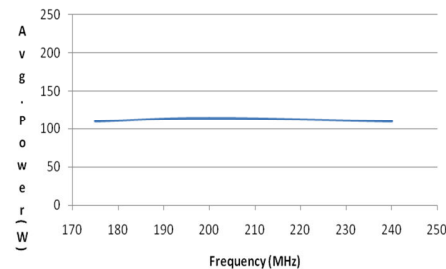

Fig. 10 AVG.DVB-T Power Output Band III

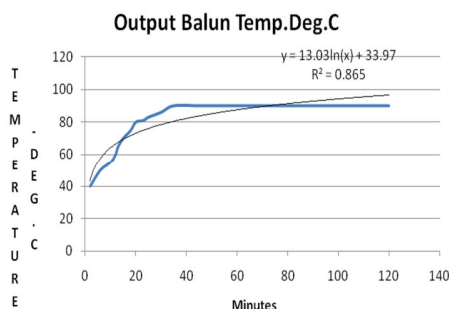

Fig. 11 Output balun Temp Deg. C

The DVB-T power output flatness response of the amplifier becomes a crucial factor as the DVB-T spectrum mask occupies several MHz of bandwidth.

According to Fig. 9, the minimum return loss is 24.9dB and the maximum 26.4 dB. Simulation of the given data provides that the average return loss across Band III is 25.9dB.

The 8K OFDM average DVB-T power output is illustrated in Fig. 10. The amplifier was biased to operate in a linear mode with  $IDQ=2A$  and  $VDD=50V$  providing an average DVB-T power of 110W across Band III. In this regard, it is worth stating that the DVB-T amplifiers enable peaks 20 times higher than their average power. Thus, the temperature dissipation on the output planar primary wide edge copper line has been measured for 140 minutes of continuous operation as presented in Fig. 11. Although there was a relatively high temperature on the output planar transformer, the amplifier was perfectly stable in terms of power output.

## V.CONCLUSION

The test results have justified that without changes in the planar transformers' dimensions, an amplifier constructed with minimum component count could function properly in Band III where the balun is a quarter wavelength and in Band II

where it is only  $\lambda/9$ . This issue opens the door for further research and development into broadband HF planar amplifier design where the magnetic material and the huge dimension requirements of the microstrip coupled lines have limited the application until today. The RF power tolerance of the planar transformers is also one of the major reasons that have forced many designers to follow the traditional transformer construction route. The maximum heat dissipation in this application of the transformers primary winding was measured at 90deg.C with air ventilation of 5 CFM (6.50m<sup>3</sup>/min) and ambient temperature of 20 degC, that can be easily tolerated by RF-35 double sided PCB for long continuous operation. The results to date which are listed above clearly indicates that the implementation of planar design in broadband, high power HF/VHF amplifier design can be improved for future new generation transmitter development with further research and investment. An example of further research and development of the planar design is to develop amplifier arrays [10], [11] using push pull topology with multiple input/outputs.

## ACKNOWLEDGMENT

This work was supported by the Research Promotion Foundation of Cyprus and the European regional development structural funds (project number EΠΙΧΕΙΡΗΣΕΙΣ/ΠΡΟΪΟΝ/0311/06).

## REFERENCES

- [1] Gajadharsing, J. R., Bosma, O., "Analysis and design of a 200 W LDMOS based Doherty amplifier for 3G base stations", Microwave Symposium Digest, 2004 IEEE MTT-S International (Volume: 2), June 2014
- [2] Freescale Application Note AN1034 "Three Baluns designs for Push-Pull Amplifiers", 1993.
- [3] Fager, Carvalho N.B., Pedro, Zirath, "Intermodulation distortion behavior in LDMOS transistor amplifiers", *Microwave Conference*, Vol.1, pp131-134 2002.
- [4] Lee, Seung-Yup; Jeon, Kye-Ik; Yong-Sub Lee; Lee, Kang-Seung; Yoon-Ha Jeong "The IMD sweet spots varied with gate bias voltages and input powers in RF LDMOS power amplifiers", *Microwave Conference, 2003. 33rd European*, on page(s): 1353 - 1356 Vol.3 Volume: 3, 7-9 Oct. 2003.
- [5] S. R. Novis and L. Pelletier, "IMD parameters describe LDMOS device performance", *Micro. RF*, vol. 37, pp.69-74 1998
- [6] S. Hayano, Y. Nakajima, H. Saotome, and Y. Saito, "A new type high frequency transformer," *IEEE Trans. Magn.*, vol. 27, pp. 5205-5207, Nov. 1991.
- [7] Freescale Semiconductor, Document Number, MRF6VP5600H Technical Data, (Rev. 1, 1/2011).
- [8] NXP Application note AN10858, "174 MHz to 230 MHz DVB-T Power Amplifier with the BLF578".
- [9] H. Granberg. (1993). Motorola Semiconductor Application Note AN749, 'Broadband Transformers and Power Combining Techniques'
- [10] H. S. Tsai, M. J. W. Rodwell, "Planar Amplifier Array With Improved Bandwidth Using Folded-Slots", *IEEE Microwave And Guided Wave Lett'ers*, Vol. 4, No. 4, April 1994
- [11] Tsung-Chi Yu, Chaoen Wang, Lung-Hai Chang, Ming-Chyuan Lin, Meng-Shu Yeh, "The Development Of High Power Solid-State Amplifier In NSRRC", Proceedings of IPAC'10, Kyoto, Japan, 2010