

Research on Modern Semiconductor Converters and the Usage of SiC Devices in the Technology Centre of Ostrava

P. Vaculík, P. Kaňovský

Abstract—The following article presents Technology Centre of Ostrava (TCO) in the Czech Republic describing the structure and main research areas realized by the project ENET - Energy Units for Utilization of non Traditional Energy Sources. More details are presented from the research program dealing with transformation, accumulation and distribution of electric energy. Technology Centre has its own energy mix consisting of alternative sources of fuel sources that use of process gases from the storage part and also the energy from distribution network. The article will be focus on the properties and application possibilities SiC semiconductor devices for power semiconductor converter for photovoltaic systems.

Keywords—SiC, Si, Technology Centre of Ostrava, Photovoltaic Systems, DC/DC Converter, Simulation.

I. INTRODUCTION

THE usage of photovoltaic panels as a power (even after the huge boom in recent years in the Czech Republic) has been still a current of issue. The TCO does not focus only on the use of direct supply energy to the grid. New research on TCO aims to store energy from solar panels to the batteries and its subsequent use during periods of high demand peaks in the electrical grid.

II. TECHNOLOGY CENTRE OF OSTRAVA

The Technology Centre Ostrava (TCO) in the Czech Republic (Fig. 1) was created within the project ENET - Energy units for the exploitation of unconventional energy sources in the 2010. It was designed as a research and development centre for the conversion of fuels, especially waste and alternative fuels, into thermal and electrical energy and its efficient usage. The objective of this centre is research and development of units (technology and energy) for the treatment of waste and alternative fuels and intensifying their conversion into thermal and electrical energy. TCO also deals with ensuring the purity of combustion, monitoring the quality and quantity of output products and simultaneously monitoring the possibility of energy storage and parallel or serial cooperation of different sources. The project also focuses on the application of the electricity produced in the

P. Vaculík is a junior researcher at the research centre ENET – Energy Units for Utilization of non Traditional Energy on the VŠB – Technical University of Ostrava, Czech Republic (phone: +420597324287; e-mail: petr.vaculik@vsb.cz).

P. Kaňovský is a masters student at the Department of Electronics on the VŠB–Technical University of Ostrava, Czech Republic (e-mail: petr.kanovsky.st@vsb.cz).

energy grid in the Czech Republic. It also does not neglect the usage of stored energy in periods of excess – Hybrid Technology – the compensation of energy swings in the power grid.

The main goals of the development centre are:

- The implementation of more efficient use of energy resources – intensification of the processes of energy transformation with the aim of design new units;
- The usage of alternative energy sources for classic technology;
- To support the usage of waste, biomass and to ensure sustainable development;
- The implementation of innovation of treatment equipment, transport and processing of input and output raw materials;
- To verify the utility of alternative fuels as alternative energy source in respect of the EU legislation;
- To achieve high efficiency of combustion and co-combustion process and all transfer phenomena [1]



Fig. 1 Technology Centre of Ostrava in Czech Republic

The outputs of the TCO are new theoretical knowledge, applied as patents and utility models and published in scientific journals, but also results applied in the form of pilot plants and certificated technologies and realized as products for companies cooperating in the research.

III. THE ENERGY SYSTEM OF TECHNOLOGY CENTRE OF OSTRAVA

One of three major research programs of the TCO is focusing on the usage, storage and distribution of electricity. The main directions of this project is to investigate the quality and reliability of electricity supply from renewable energy

sources, development of power semiconductor converters for renewable energy, hydrogen technology research Smart Grids and accumulation of heat and electricity.

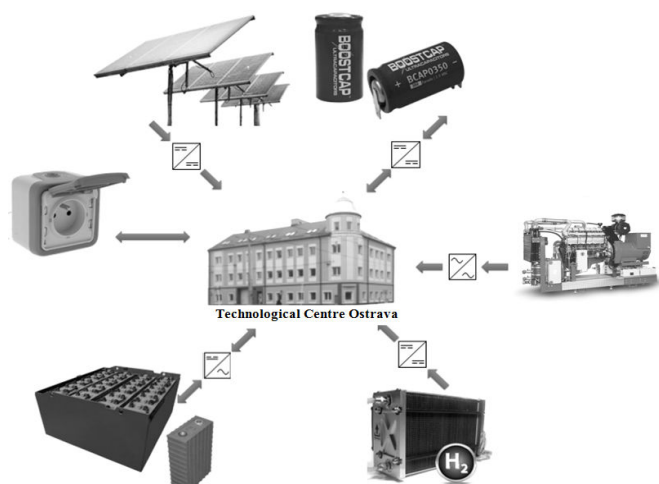

Fig. 2 Energy mix in Technology Centre Ostrava

Fig. 2 illustrates an electric power system in the TCO. This energy mix consists of parts of alternative sources (solar panels, fuel cells). Into the system enter the resources of the changing energy combustion industrial gases (pyrolysis gas, landfill gas, biogas, etc.) supplied from generators cogeneration unit or Stirling engine. The power grid centre is connected to the distribution network that ensures the delivery of energy (especially when surpluses of energy in the network) or backward energy distribution (lack of energy in the network). The last parts of the power energy grid are storage elements made of high-performance lead-acid traction batteries, lithium batteries, or ultracapacitors battery.

IV. THE CURRENT STATUS OF THE PHOTOVOLTAIC SYSTEM

The following chapter describes the current status of photovoltaic panels arranged in three sections on the roofs of the TCO. These sections are further divided into strings, which are connected in the switchboard inside the building. Each section has its own power semiconductor converter (section no. 2 has two inverters due to higher power) that connect the solar panels to the grid (Fig. 3).

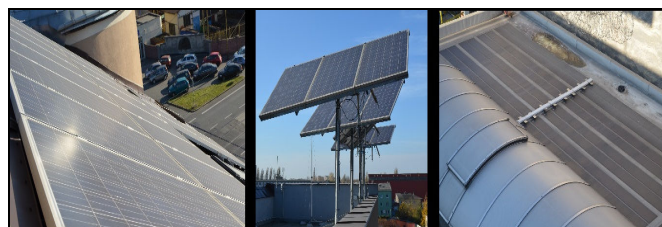

Fig. 3 Three types of photovoltaic panels on the roof of TCO – static panel, tracker and amorphous cells

The first panel section consists of a static monocrystalline solar cells placed on the roof of the TCO. Overall there have been installed 60 panels which are divided into six strings

(Fig. 4). The second section contains adjustable (positional or swivelling) solar panels, called trackers. These trackers automatically tilt and rotate the panel to the sun to ensure the maximum possible efficiency of the panels. Trackers are made up of two sensors that track the sun and evaluate possible tilt by the DC motor. The second section has 18 panels divided into two strings. In the last sections are applied solar panels on the roof of the near hall. It is inappropriate orientation of the roof and therefore there were used amorphous cells. These cells can accommodate larger solar spectrum solar radiation, and thus are the best solution for the site. Overall, this is a 10 pcs panels placed in five strings. These cells can absorb larger spectrum of solar radiation and therefore are the best solution for the site. In total there are ten panels placed in five strings.

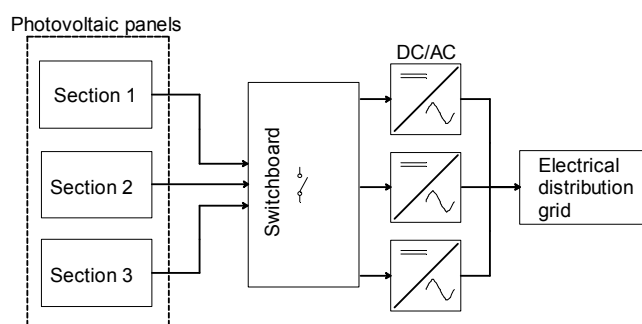

Fig. 4 The current status of the Photovoltaic system in TCO

More detailed description of the electrical parameters and the number of panels and strings in individual sections is summarized in the following Table I.

TABLE I
 NOMINAL PARAMETERS FOR EACH PHOTOVOLTAIC SECTION

Parameters	SECTION 1 static panel	SECTION 2 trackers	SECTION 3 amorphous
Number of panels	60 pcs	18 pcs	10 pcs
Power of panel	210 Wp	230 Wp	576 Wp
Number of string	6	2	5
Number of panel in one string	10	9	2
The total installed capacity	12.6 kWp	4.1 kWp	5.8 kWp
Maximum no load voltage	364 V	336 V	370 V
Maximal current of section	47,2 A	16 A	26,5 A

V. THE NEW CONVERTERS IN THE PHOTOVOLTAIC SYSTEM

For the integration of electric power from solar cells to the internal network energy mix of TCO research has been focused on the development of new DC/DC converters which are alternative to existing inverters. These converters are in function of one-quadrant and boost DC/DC converter which will charge a secondary storage battery in common repository of TCO.

The construction of this converter will be designed as small compact modules (Fig. 5). For each string will install one DC/DC converter. For section 1 will install 6 pcs of converters,

for section 2 will be 2 pictures and for section 3 will be 5pcs of converters. This modular system accelerates the design, production reducing costs, speeding up service. Further advantage of this modular solution is better use of photovoltaic panels to manage their working point for each string separately.

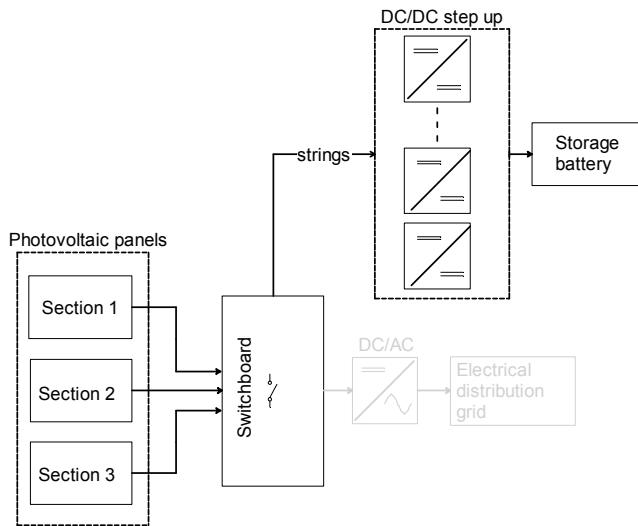

Fig. 5 The photovoltaic system in TCO with new converters

VI. THE USE OF SiC SEMICONDUCTOR DEVICES FOR DESIGN OF CONVERTER - BASIC PROPERTIES OF SiC

SiC material for semiconductor devices manufacturing has been known since the 1930s. The starting disadvantage of this material was quality (initially limited to material stability and pollution), size and cost. These disadvantageous properties were substantially improved over just the several years and a rival for silicon semiconductor devices was created. In the next 10 years, SiC will join silicon as a mass manufacturing material for semiconductors. The total SiC semiconductor devices' market revenue (including power, opto & high-temperature) stands at approximately \$218 million in 2012 and is expected to reach \$5.34 billion by 2022. [2], [3]

The design of converters with high switching frequencies (hundreds of kHz) brings many challenges. The proposal must be performed precisely and with respect to certain principles. Failure to comply with the design principles of the switching transistor causes considerable surges that are dangerous in terms of breakdown of the transistor. Fast switching causes problems with overvoltages and also parasitic oscillation damping. From these basic considerations it follows that it is impossible to create a functioning converter with high switching frequency on the unsoldered field or wire to wire connection components. For the converter with switching frequencies of hundreds of kHz, it was necessary to use ultra-fast switching switch with minimally 800 V reverse voltage. Such very strict requirements are met by the MOSFET transistors with SiC semiconductor material which are ultra-fast switching and have a blocking voltage of 1200V.

SiC material has the following key features that make it a superior semiconductor material in comparison with previous Si materials:

- The band gap is defined as energy difference between valence and conduction band in a material. The width of this band depends on the motion of minority carrier, respectively on thermal generation of current flow. This current leakage is very low in comparison with silicon material.
- The higher breakdown field of SiC is almost nine times thinner than the breakdown field of silicon.
- The thermal conductivity in SiC is higher than in GaAs and more than three times higher than the conductivity of Si. At room temperature 4H SiC has a higher thermal conductivity than copper.
- The semiconductor material operates in an extreme junction temperature up to 800°C (theoretically), but experimental results were obtained at temperatures up to 600°C, verifying the dependence between temperature and motion minority carrier. Results are better for SiC than for its counterparts. Nowadays, the manufacturer faces a problem with case for these high temperature devices.

SiC diode technology has been in the market for more than one decade, and many switches have recently become available to enable "all-SiC" circuit solutions. SiC diode and transistor production on voltage type 600 V, 1200 V and 1700 V and current rates up to 100 A. Use of SiC in specifically the industrial, power, solar & wind sector (for power applications) also enables smaller heat sink, passive, and magnetic nature in system designs. SiC electronics also find applications in electric vehicles and hybrid electric vehicles, rail transportation, power supply units, photovoltaic applications, converters & inverters, and many more. [2], [3]

The implementation of SiC technology in the market of power semiconductors for motor control occurred in two stadium. In the first phase was the parallel Si PiN diode in IGBT module replaced a SiC Schottky Barrier Diode (SBD). The second phase was replacement of the IGBT with a SiC MOSFET transistor. This evolution provides switching loss reduction, leading to higher density of power modules that can operate at higher junction temperatures. The main feature of Schottky diodes (SiC or Si) is high-speed switching. Main advantage of SiC SBD is the ten times greater reverse breakdown voltage than Si technology PiN diodes. This feature allows using SiC diode in high-speed devices in high-voltage inverters. The greatest advantage SiC SBD over Si diodes in high-power switching applications is its characteristic zero reverse recovery current (minimal Q_{rr} during turn-off), even at the highest junction temperature operation allowable. [2]

VII. THE SIMULATION OF DC/DC BOOST CONVERTERS FOR PHOTOVOLTAIC SYSTEM WITH Si OR SiC SWITCHING DEVICES

In this chapter has been presented simulation model of boost DC/DC converters with SiC and Si switching devices. There was searched for the optimal switching frequency of

converters with regard of high efficiency devices, compared to power losses of SiC and Si semiconductors and find the best value of working inductance of converter. [5], [6]

A. Simulation Model with SiC Semiconductor Devices

The simulation model of the SiC MOSFET transistor and the SiC SBD diode was obtained on request from the manufacturer Cree, Inc. The simulation scheme of boost converter (Fig. 6) was created in LTspice program, which is freely available on the company website of Linear Technology. [4]

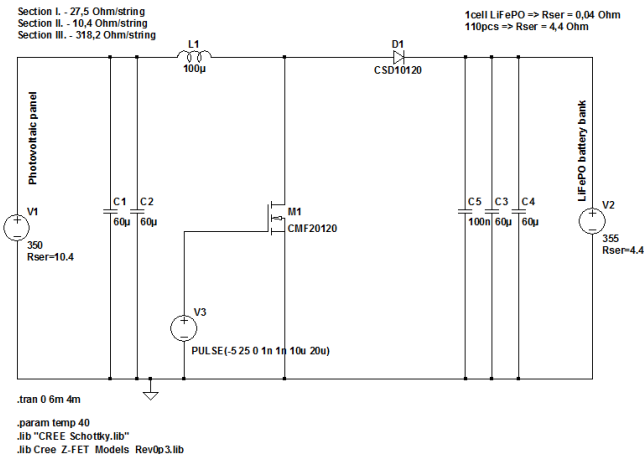

Fig. 6 Simulation scheme of boost DC/DC converter with SiC semiconductors

The simulation scheme (Fig. 6) contains a semiconductor switch - MOSFET transistor (Cree, type CMF20120) and diode (Cree, type CSD10120). Photovoltaic panels represent a source (on the left side of the scheme) with voltages 350 V. Series resistance was determined by experimental measurement to 10.4 Ω for one string of section II. This most powerful section was selected as a worst case for the simulation of converter. The accumulator battery LiFePO (source on the right side of the scheme) is composed of 110 pcs with nominal voltage 355 V.

Simulation tasks have been made for switching frequency of 5, 10, 50, 150, 200, 300, 400 and 500 kHz and for the inductance of the converter coils 39, 75, 100, 150 μH.

B. Simulation Model with Si Semiconductor Devices

The simulation scheme (Fig. 10) contains common of Si semiconductor devices. Due to low reverse voltage of Si MOSFET transistors, IGBT transistor was been selected (Fairchild Semiconductor, type FGL40N120AND) with similar parameters as SiC transistor (1200 V, 40 A). In function of the diode is reverse in the simulation the scheme) using the internal diode IGBT transistor FGL40N120AND.

Simulation tasks are made for the same switching frequency and the same value of converters inductance of the coil as for SiC version.

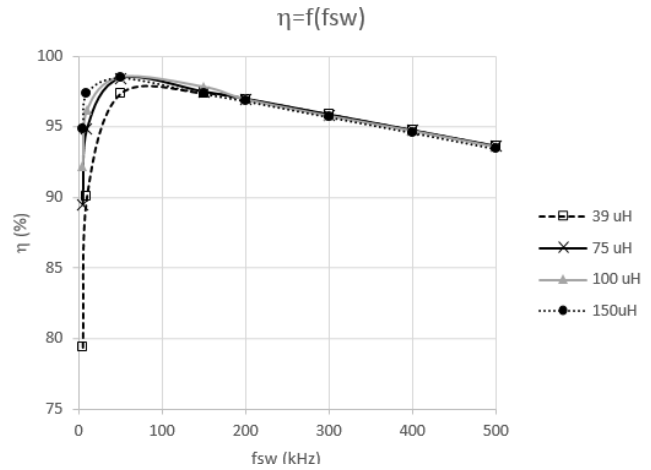

Fig. 7 Simulation results of SiC converter efficiency

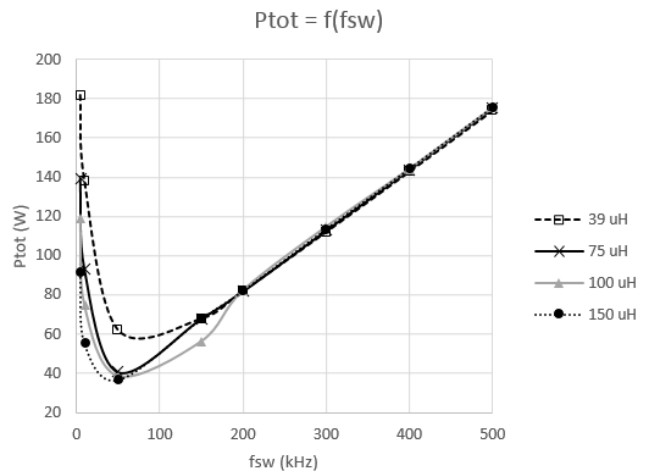

Fig. 8 Simulation results of SiC semiconductors power lost

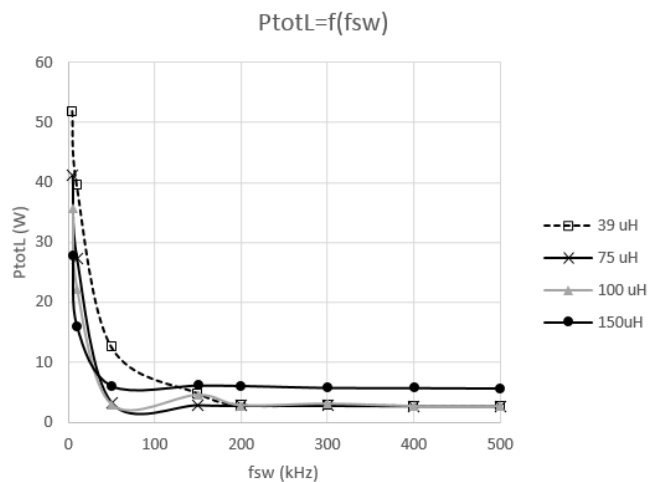

Fig. 9 Simulation results of inductors lost of SiC converter

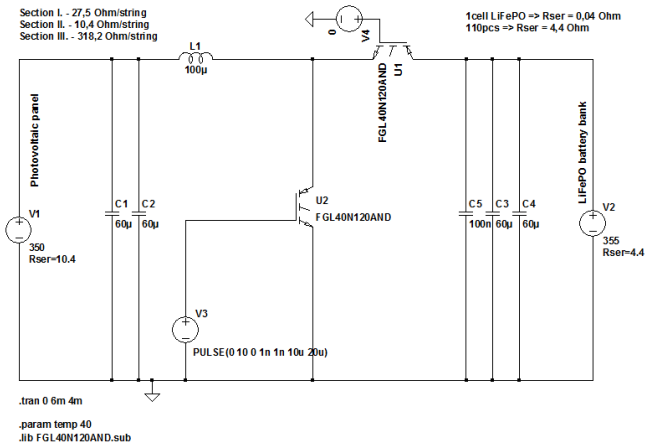

Fig. 10 Simulation scheme of boost DC/DC converter with Si IGBT transistor

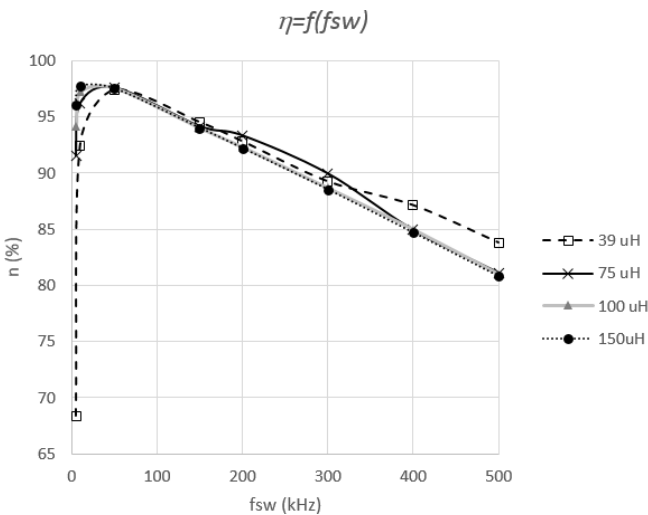

Fig. 11 Simulation results of Si converter efficiency

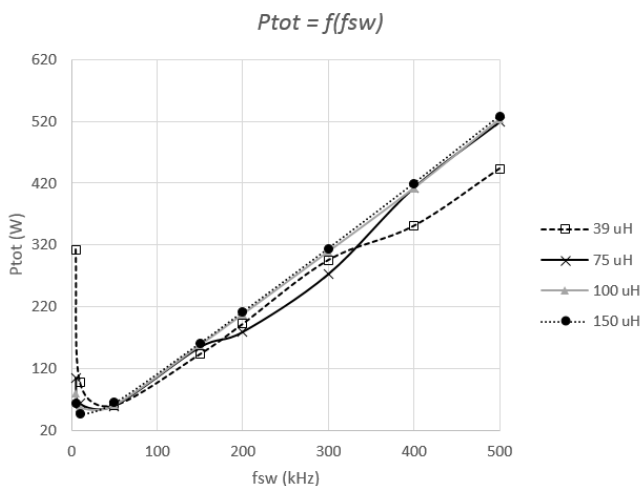

Fig. 12 Simulation results of Si semiconductors power lost

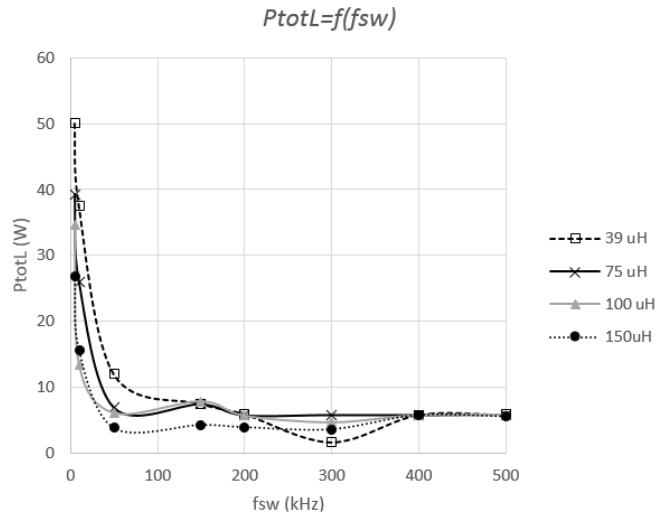

Fig. 13 Simulation results of inductors lost of Si converter

C. Comparison of Simulation Results of Si and SiC Converter

The comparison of simulation results of SiC and Si converters was related to the efficiency both inverters for the selected switching frequency and value of inductance. The following chart (Fig. 14) shows that at low switching frequencies of the order of 50 kHz, the efficiency of both inverters almost identical. With the increased switching frequency has been the efficiency of SiC semiconductor as compared with Si better (1% @ 50 kHz, 4% @ 150 kHz, 5% @ 200 kHz, 7% @ 300 kHz, 10% @ 400 kHz, 13% @ 500 kHz).

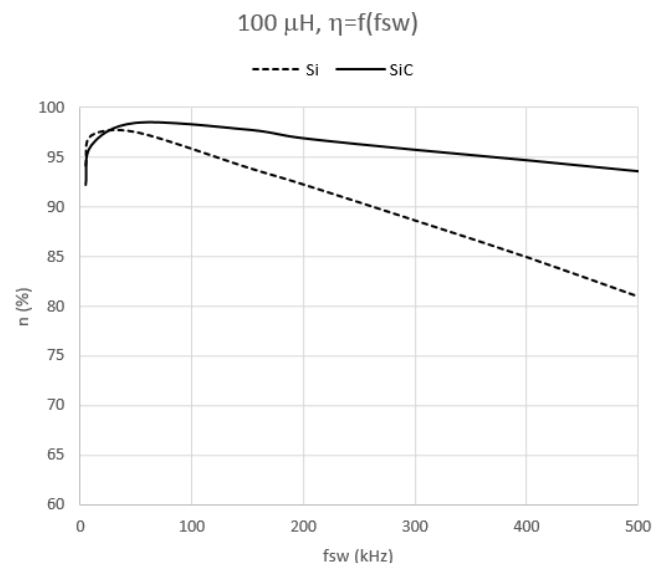

Fig. 14 Simulation results of Si and SiC converters efficiency for inductance 100 µH

VIII. CONCLUSION

The first step in the development of DC/DC converters for charging batteries by photovoltaic panel in TCO was to create research the current state of the system and then perform the simulation scheme of converter. Balance sheet was made over

the use of conventional switching elements Si or SiC modern semiconductors. From the simulation it is evident that it has been preferable to use SiC switches in inverter with switching frequency greater than 50 kHz. From the simulations (Figs. 7-9), it appears to be clear that as an optimal utilization appears switching frequency from 100 to 200 kHz when inductance of the coil 100 μ H. Above mentioned simulation results will be used for the construction design and realization of DC/DC converters.

ACKNOWLEDGMENT

This paper has been elaborated in the framework of the project New creative teams in priorities of scientific research, reg. no. CZ.1.07/2.3.00/30.0055, supported by Operational Programme Education for Competitiveness and co-financed by the European Social Fund and the state budget of the Czech Republic and ENET CZ.1.05/2.1.00/03.0069 – Energy Units for Utilization of non Traditional Energy.

REFERENCES

- [1] ENET-Energetické jednotky pro využití netradičních zdrojů energie. *Enet* (online). 2010 (cit. 2014-11-13). Dostupné z: <http://enet.vsb.cz/cs/>
- [2] Vaculik, Petr. The Properties of SiC in Comparison with Si Semiconductor Devices. APPEL. Pilsen, 2013.
- [3] SiC's advantages over silicon push more SiC semiconductors over 10 years. *Solid State Technology* (online). 2012-06-29 (cit. 2014-11-13). Dostupné z: <http://electroiq.com/blog/2012/06/sic-advantages-over-silicon-push-more-sic-semiconductors-over-10-years/>.
- [4] Linear Technology. Design Simulation and Device Models: Linear Technology. Linear Technology. (Online) Linear Technology, 12. 02. 2013. (26. 03. 2013) <http://www.linear.com/designtools/software/>.
- [5] Kazimierczuk, Marian. *Pulse-width modulated DC-DC power converters*. Chichester, U.K.: Wiley, 2008, xxvi, 782 p. ISBN 9780470773017.
- [6] BASSO, Christophe P. *Switch-mode power supplies: SPICE simulations and practical design*. New York: McGraw-Hill, 2008, xix, 889 s. ISBN 978-0-07-150859-9.