

Dynamic Performance Evaluation of Distributed Generation Units in the Micro Grid

Abdolreza Roozbeh, Reza Sedaghati, Ali Asghar Baziar, Mohammad Reza Tabatabaei

Abstract—This paper presents dynamic models of distributed generators (DG) and investigates dynamic behavior of the DG units in the micro grid system. The DG units include photovoltaic and fuel cell sources. The voltage source inverter is adopted since the electronic interface which can be equipped with its controller to keep stability of the micro grid during small signal dynamics. This paper also introduces power management strategies and implements the DG load sharing concept to keep the micro grid operation in grid-connected and islanding modes of operation. The results demonstrate the operation and performance of the photovoltaic and fuel cell as distributed generators in a micro grid. The entire control system in the micro grid is developed by combining the benefits of the power control and the voltage control strategies. Simulation results are all reported, confirming the validity of the proposed control technique.

Keywords—Stability, Distributed Generation, Dynamic, Micro Grid.

I. INTRODUCTION

MICRO GRIDS are integrated energy systems consisting of interconnected loads and distributed energy resources which as a system can operate in parallel with the grid or in an intentional island mode. Micro grid has a special superiority on not only improving power quality and reliability but also relieving pressure of energy and environment [1], [2].

Generally, distributed generation units refer to small-scale electric power generators that produce electricity at a site close to the customer or an electric distribution system (in parallel mode). From the customers' viewpoint, a potentially lower cost, higher service reliability, high power quality, increased energy efficiency, and energy independence could be the key points of a suitable DG unit. Moreover, the utilization of renewable kinds of distributed generations such as wind, photovoltaic, geothermal or hydroelectric power can also provide significant environmental benefits [3].

Distributed generation systems are also presented as a suitable solution offer high reliable electrical power supply as well as make up local ac micro grids [3]. And different kinds of energy resource are available, such as photovoltaic panels, fuel cells, or speed wind turbines. Most of these energy sources need inverters as interfaces which connected to an ac common bus. In addition, every unit must be able to operate independently when communication is too difficult due to the long distance used in micro grid. Parallel operations of inverters are increasingly developed to obtain redundant

power system and create micro grid systems [4]. The reliability as well as the power capability of the supply system can be increased by replacing a single inverter unit with more and smaller inverter units in paralleling. These techniques need some forms of control interconnection among the paralleling inverters [5], [6]. These interconnecting wires not only restrict the location of the inverter units, but can also act as a source of noise and failure. Therefore, the system is not truly distributed or redundant. This paper presents a control method that can manage the power sharing among the DG units in both grid-connected and islanded modes. The proposed control method is tested in three typical scenarios namely grid connected mode, islanded mode, and transition mode. The power electronics interfaces, such as a voltage source inverter plays a vital role in interfacing the DG units with the utility grid. The dynamic models available in the PSCAD/EMTDC simulation software for fuel cell, photovoltaic and the power inverters enable simulation for both the steady and dynamic behavior of the three-phase micro grid. The control strategy is developed to combine the advantages of the power control and the voltage control strategies. The former is to be preferred to ensure stability of the whole conversion system, while the latter allows a more accurate generation of the reference voltages necessary to apply the pulse width modulation (PWM) technique. The combined use of the two control modes allows the implementation of a simple and effective three-phase control scheme, particularly to deal with critical conditions that can occur in the micro grids. In order to test the performance of the control strategy, two DG units are connected to the main grid system in the simulation. Simulation results suggest that this control method can make the parallel-connected inverters to improve the micro grid performance.

II. CONTROL STRATEGY

Two DG units were considered in this study. Each DG unit comprises of a dc source, a PWM voltage source inverter (VSI) and LC filters [7]. Fig. 1 details the interconnection between DG units with main grid. They are connected at the point of common coupling (PCC). In islanded mode, the two DG units are controlled to provide local power and voltage support for loads 1 to 3. This configuration reduces the burden on generation and delivery of power directly from the main grid and enhances the immunity of critical loads to system disturbances in the grid. An inverter can operate in two modes either in the grid-connected mode by using power control or the isolated mode using voltage control.

Abdolreza Roozbeh, Reza Sedaghati, Ali Asghar Baziar, and Mohammad Reza Tabatabaei are with the Department of Electrical Engineering, Zarghan Branch, Islamic Azad University, Zarghan, Iran (e-mail: roozbeh_a@yahoo.com).

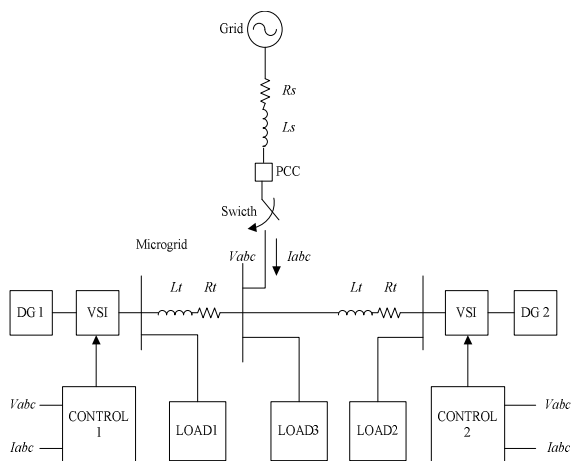

Fig. 1 Test system

A. Operation of Grid-Connected Mode

In order to control output active and reactive powers by develop the control system which is implemented in the dq0 reference frame. Components i_d and i_q of the inverter output current are controlled by means of reference values I_{dref} and I_{qref} , obtained as outputs of the block called power control. To obtain the previously mentioned reference signals, a power measurement at the inverter output provides the values of the active and reactive powers injected into the network, P_{in} and Q_{in} . This quantity is compared with the reference values given for each P_{ref} and Q_{ref} . The errors, dP and dQ , between the output powers and the reference ones, provided as inputs to a PI, allow to generate the reference signals, I_{dref} and I_{qref} . This comparison provides the errors, ΔI_d and ΔI_q , which will be subsequently passed through PI controllers, obtaining the inverter modulating signals of PWM. Then, by means of a dq0-to-abc transformation block, this signal is provided to the inverter whose implementation is shown in the Fig. 2.

B. Operation of Islanded Mode

In order to accomplish an islanded mode operation, a suitable control is needed for DG units. The islanded mode of operation requires the control that differs from the grid-connected mode. In voltage control mode, the system has been disconnected from the utility grid. Therefore the voltage is no longer regulated by the grid. Because of this, the control needs to actively regulate the voltage of the local load and hence a voltage control technique is used to regulate the output of the voltage source inverter.

When the inverter switches from the islanded mode to the grid-connected control mode, the inverter output voltage should be synchronized to the grid, which is achieved by using a phase-locked loop (PLL). The PLL assigned to transform and track the VSI voltage, frequency and angle, special consideration needs to be taking into account for the generation of the angle. When the system is operating in the grid-connected mode, the PLL tracks the grid voltage. In this mode, the grid and VSI voltages are made equal to ensure synchronization; but when the system enters an islanding

mode of operation, the VSI can no longer track the grid voltage characteristics. In the islanding mode of operation, the VSI needs to have an external frequency reference.

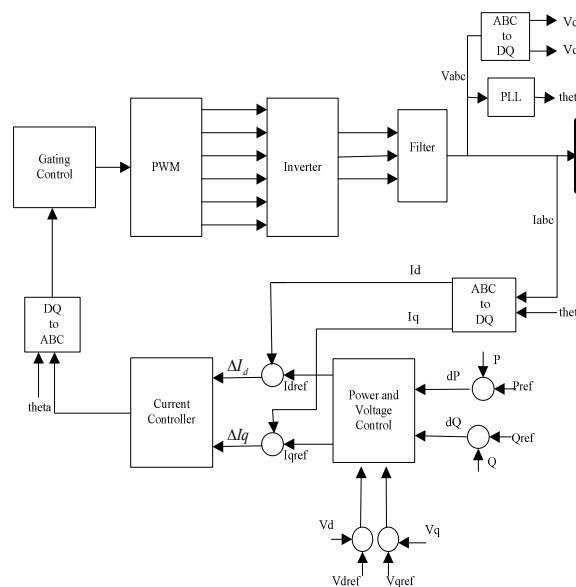

Fig. 2 Block diagram of PWM control of voltage source inverter

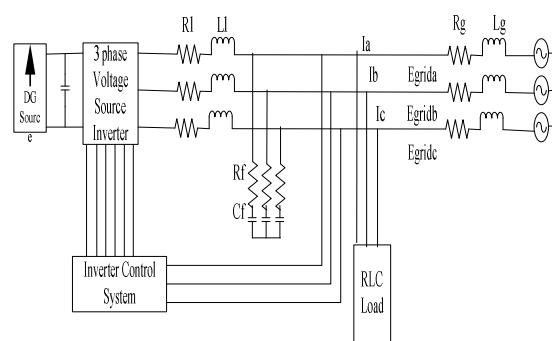

Fig. 3 Inverter control system for each distributed generation

The configuration of the grid-connected inverter, used in each DG micro grid system under examination is shown in Fig. 3. The inverter transfers the energy produced by the power source on the micro grid, controlling the power flows through suitable impedance. This is constituted by three impedances of resistance $R1$ and inductance $L1$ and a parallel capacitive filter providing a path for some high-order harmonics at the switching frequency. Considering that the inverter operates in voltage control mode, its controller generates three reference signals E_{grida} , E_{gridb} , E_{gride} , each of which is referred to the output voltage that is to be applied on each phase, so that the impedance current I_a , I_b , I_c , tracks its desired value corresponding to the power flows required between the dc and ac sides. Obviously, it is needed that the output voltages of the VSI to track the reference voltages by applying the PWM technique. The performance of the proposed control strategies was evaluated by computer simulation using PSCAD/EMTDC simulation software [8]. The system was operated initially in grid-connected mode. To

verify the effectiveness of the proposed control method in this simulation, the following scenarios was carried out by scenario (1) Grid connected mode (Switch close), (2) Islanded mode (Switch open) and (3) Transition mode (Switch open and close within 2 seconds).

III. MATHEMATICAL MODEL OF A FUEL CELL AND PHOTOVOLTAIC

Different DG units are considered to form the micro grid. The dynamic models are integrated into the micro grid [9]. A detailed description of the models adopted for solid oxide fuel cells and photovoltaic generation systems have to be utilized to connect through inverters. A simple model is hereby adopted for the inverters, in which the switching as well as the internal loss has been ignored.

A. Solid Oxid Fuel Cell Model

A simulation model is developed for the SOFC in PSCAD/EMTDC based on the dynamic SOFC stack as shown in Fig. 4. The parameters of this model are given in [10, 11]. Considering ohmic losses of the stack, the expression of total stack voltage can be written as

$$V_{fc} = N_0 \left(E_0 + \frac{RT}{2F} \left(\ln \frac{P_{H_2} P_{O_2}^{0.5}}{P_{H_2O}} \right) \right) - rI_{fc} \quad (1)$$

where V is total stack voltage (V), E_0 is Standard reversible cell potential (V), r is internal resistance of stack (Ω), I is stack current (A), N is number of cells in stack, R is universal gas constant (J/ mol K), T is stack temperature (K), F is Faraday's constant (C/mol), P_{H_2} is partial pressure of hydrogen, P_{O_2} is partial pressure of oxygen and P_{H_2O} is partial pressure of water. The total power generated by the fuel cell is:

$$P_{fc} = N_o VI \quad (2)$$

B. Photovoltaic Model

A dynamic model of a photovoltaic array system is developed as the DG2 shown in Fig. 5. In order to extract the maximum efficiency from a solar cell it is necessary to operate the cell at the point where the cell delivers maximum power. PV cells are grouped in larger units to form PV modules, which are then interconnected in a parallel-series configuration to form PV arrays. Output voltage of the PV cell is a function of the photocurrent that depends on the solar irradiation level during its operation. The output current of the PV cell is represented by (3). For the PV array consisting of N_s series module and N_p parallel branches, the PV voltage and current are given by (4) and (5). The power output of the PV cell is the product of output current and output voltage of PV, which is represented by (6).

$$I_c = I_{ph} - I_o = I_{ph} - I_{sat} \left[e^{\frac{q}{AKT_c}(V + IR_s)} - 1 \right] \quad (3)$$

$$V_{pv} = N_s \times (V_{ref} - \beta(T - T_{ref}) - R_s(T - T_{ref})) \quad (4)$$

$$I_{pv} = N_p \times \left(I_{ref} + \alpha \left(\frac{G}{1000} \right) (T - T_{ref}) + \left(\frac{G}{1000} - 1 \right) I_{sc} \right) \quad (5)$$

$$P_{pv} = I_{pv} \times V_{pv} \quad (6)$$

where I_{ph} is the light generated current in a PV cell, I_o is the reverse saturation current of diode, T_c is cell temperature in Kelvin, A is Ideality factor, K is Boltzman constant, q is electron charge, α is current temperature coefficient, G is irradiance, β is voltage temperature coefficient, N_s is number of modules connected in series and N_p is number of modules connected in parallel.

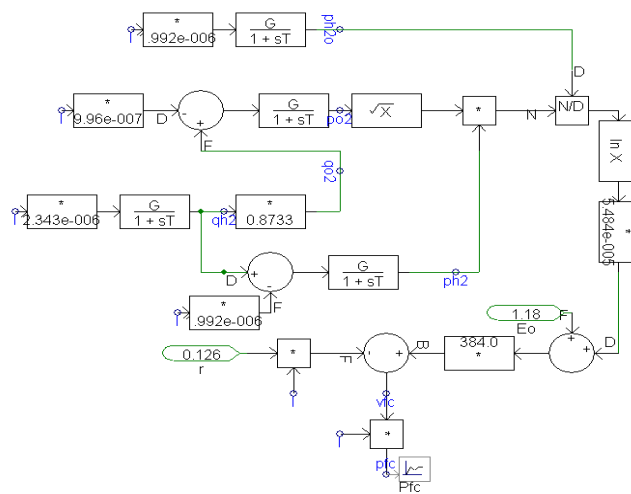

Fig. 4 PSCAD/EMTDC implementation of SOFC

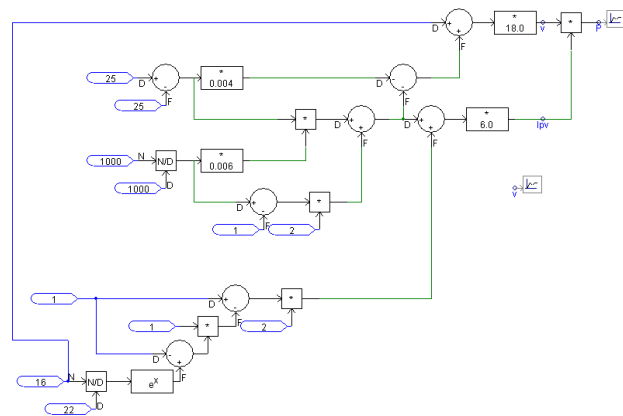

Fig. 5 PSCAD/EMTDC implementation of photovoltaic

IV. SIMULATION RESULTS

The various simulations were carried out for the system as shown in Fig. 1. In this configuration, the DC components, which represent the DC voltage source, are modeled as fuel cell and photovoltaic sources. To examine the validity of the simulation platform, the following scenarios was carried out by scenario namely grid connected mode (Switch close), islanded mode (Switch open) and Transition mode (Switch open and close within 2 seconds).

A. Grid Connected Mode

Initially, the transfer switch (Switch) was on at 0.2sec and the DGs were all operating in the power control mode. Their output power could be controlled respectively. The variation of real and load power are shown in Figs. 6 and 7. The power from the grid is 0.25MW and power from both DG is 0.05MW. In the Fig. 9 shows the load1, 2 and 3 are consume the same power about 0.100MW. During an additional load of 50% at $t= 1$ sec, the power from the grid will reduce and power will manage by the two DG units that will increase in power to provide the sufficient power to the loads respectively as shown in Figs. 8 and 9.

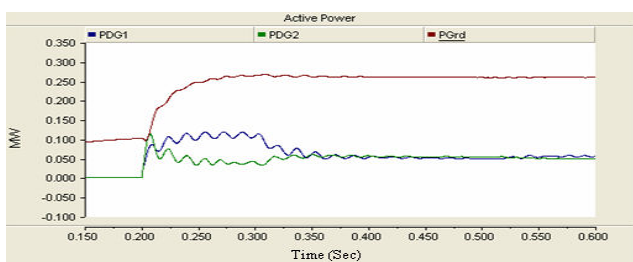

Fig. 6 Active output powers

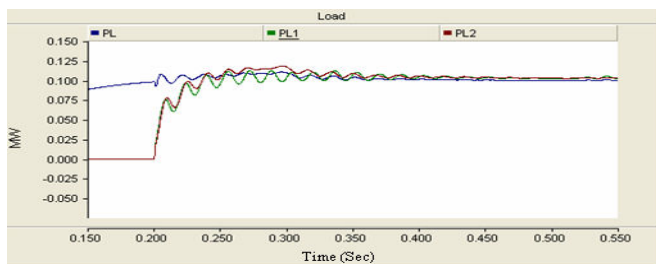

Fig. 7 Load powers

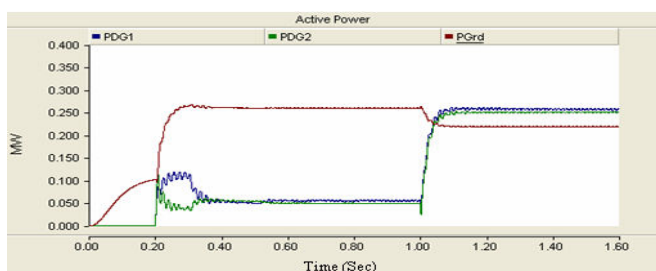

Fig. 8 Active output powers

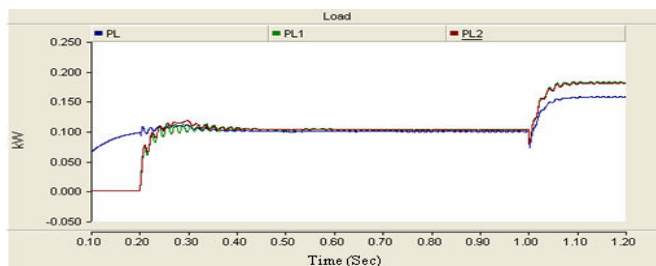

Fig. 9 Load powers

B. Islanding Mode

In this simulation, the transfer switch (Switch) was initially off at 0.2 sec and the DG units were all operating in the isolated mode. All distributed generation started to work in the voltage control mode. When the switch is opened the DG units continues to supply the power to the load in Fig. 12 without the main supply. Under this condition, the DG units generate higher power to meet the load requirements. At any load amount, the DG units should be able to meet the voltage amplitude and frequency reference of the main grid. During this mode, the power only produces by the DG units is about is 0.15MW in Figs. 10 and Fig. 11 shows the load1, 2 and 3 are consume the same power about 0.085MW.

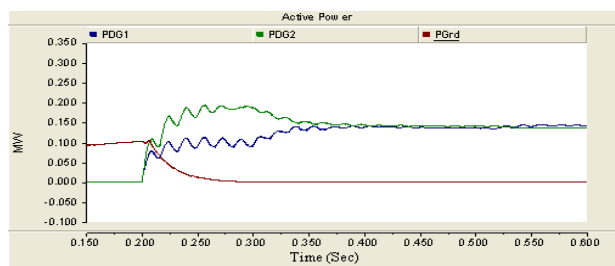

Fig. 10 Active output powers

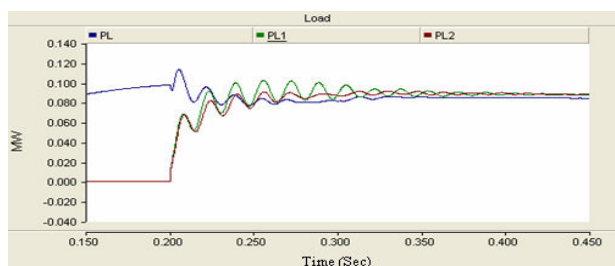
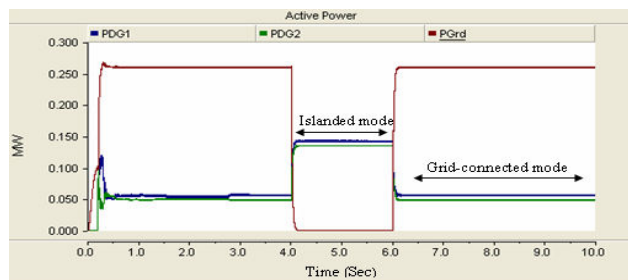

Fig. 11 Load powers

C. Transition Mode

In the simulation, initially the transfer switch (Switch) was on which is operating in the power control mode. At 5sec, the transfer switch was turned off and transfer switch (Switch) at the bus connected to the grid is opened. When the grid is disconnected from the system, the DG units increases its power so as to compensate for the loss of grid supply at a period of 4 to 6sec is shown in Fig. 12 (a). An amount of power to be support for total load is increasing from 0.050MW to 0.150MW in islanded mode. The simulation shows, the proposed method for controlling DG unit is effective during islanding in 2sec from main grid. And also, this method of control guarantee continuity of power supply to loads after islanding from main utility grid that the inverter controls respond accordingly, with the load voltage returning quickly to its pre-disturbance value is shown in Fig. 12 (b).



(a)

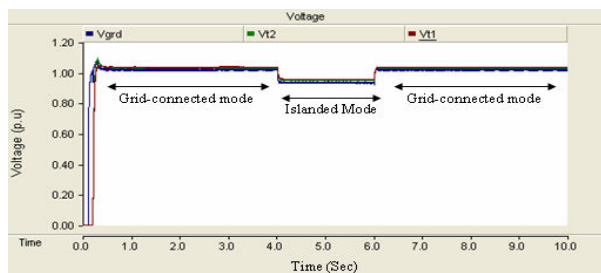

(b)

Fig. 12 (a) Transition mode with two distributed generation system in operation and (b) Load Voltage

V. CONCLUSION

This paper presented appropriate control systems for local generators able to correctly manage a micro grid during its transition from the grid-connected to an islanded operation. To be able to study the dynamic behavior of a micro grid including fuel cell and photovoltaic generation units interfaced with the network by voltage source inverter. It's been developed and implemented for the both DG units and directly connected to the network. The dynamic performance of the micro grid is studied with disturbances. A control technique for the inverter switching signals has been discussed. Furthermore, the models for the three-phase inverter are simulated and verified will be controllable to be 1p.u.

REFERENCES

- [1] Executive Office of the President, "Economic Benefits of Increasing Electric Grid Resilience to Weather Outages," <http://energy.gov/oe/articles/white-house-council-economic-advisers-and-energy-departmentrelease-new-report>, Aug 2013.
- [2] M. Smith, and D. Ton, "Key Connections: The U.S. Department of Energy's Microgrid Initiative," *IEEE Power and Energy Magazine*, 11(4), Jul 2013.
- [3] "Trends in Microgrid Control," IEEE PES paper to be released Jul 2014.
- [4] R. A. Messenger, J. Ventre, *Photovoltaic Systems Engineering* (2nd ed.), CRC Press, New York, 2004.
- [5] O. Wasynczuk, N. A. Anwah, "Modeling and dynamic performance of a self-commutated photovoltaic inverter system," *IEEE Trans. Energy Conversion*, vol. 4, pp. 322-328, Sep. 2007.
- [6] Marnay, C. and O. Bailey, "The CERTS Microgrid and the Future of the Microgrid," LBNL-55281, August 2004.
- [7] B.R. Kroposki, T. Lasseter, S. Ise, S. Morozumi, N. Papatlianassiou, N. Hatziaargyriou, "Making Microgrids Work," *Power and Energy Magazine, IEEE*, pp. 40-53, May 2008.
- [8] R.H. Lasseter, P. Piagi, "Microgrid: A Conceptual Solution," *PESC'04 Aachen, Germany*, pp.20-25, June 2004.
- [9] Manitoba HVDC Research Center, *PSCAD/EMTDC User's Manual. Manitoba*, 1988.

- [10] Y. Zhu, K. Tomsovic, "Development of models for analyzing the load performance of microturbines and fuel cells", *Electric Power System Research*, Vol.62, p.1-11, 2004.
- [11] Katiraei F., Irvani M.R, "Power management strategies for a microgrid with multiple distributed generation units", *IEEE Trans. on Power Systems*. Vol.21, No.4, p. 1821-1831, 2006.