

Ultrasensitive Hepatitis B Virus Detection in Blood Using Nano-Porous Silicon Oxide: Towards POC Diagnostics

N. Das, N. Samanta, L. Pandey, C. Roy Chaudhuri

Abstract—Early diagnosis of infection like Hep-B virus in blood is important for low cost medical treatment. For this purpose, it is desirable to develop a point of care device which should be able to detect trace quantities of the target molecule in blood. In this paper, we report a nanoporous silicon oxide sensor which is capable of detecting down to 1fM concentration of Hep-B surface antigen in blood without the requirement of any centrifuge or pre-concentration. This has been made possible by the presence of resonant peak in the sensitivity characteristics. This peak is observed to be dependent only on the concentration of the specific antigen and not on the interfering species in blood serum. The occurrence of opposite impedance change within the pores and at the bottom of the pore is responsible for this effect. An electronic interface has also been designed to provide a display of the virus concentration.

Keywords—Impedance spectroscopy, Ultrasensitive detection in blood, Peak frequency, Electronic interface.

I. INTRODUCTION

BIOSENSORS can play an important role in areas such as diagnostic of diseases, drug detection and food quality control. Virus infections are a major cause of mortality and rapid identification of the virus has important clinical, economical and epidemiological implications. So, there is a growing need for virus sensors with improved sensitivity and dynamic range, for applications including disease diagnosis, pharmaceutical research, agriculture, and homeland security. The traditional methods for virus diagnostic are Enzyme Linked Immunosorbent Assay (ELISA) [1] and Reverse Transcriptase Polymerase Chain Reaction (RT-PCR) which are time consuming and expensive [2]. In terms of the transduction techniques used, the three main classes of biosensors are optical, electrochemical and piezoelectric. Out of the three, electrochemical methods appear to be optimum in terms of sensitivity, rapidity and portability. They can be amperometric or impedimetric, depending on whether they monitor a current as a function of potential or the resulting sensor impedance as a function of frequency. The advantage of impedimetric methods is that, unlike amperometry, they do not need enzymatic labels for detection.

Various nanostructures like nanowires, nanotubes and nanopores have been extensively explored for label free

conductance type biosensors and also for detection of a single molecule in synthesized solutions. However, their major limitation is that the detection limit of biomolecules in physiological fluids like blood is only in the range of few pM [3]-[7]. There have been several attempts to push down the detection limit by performing the noise analysis of the conductance fluctuation [8], [9]. A recent paper on Plasmonic ELISA based ultrasensitive detection of disease biomarkers with the naked eye in blood down to attomolar concentration has been reported but it requires expensive plasmonic gold nanoparticles as labels [10].

In this paper we report an immunosensor on electrochemically fabricated silicon oxide nanoporous structure and show experimentally that it is capable of ultrasensitive label free detection of HBsAg in blood through antibody-antigen interactions not only by change in impedance values but also by a different mechanism of shift in peak frequency corresponding to maximum sensitivity.. This may be possible due to the presence of additional junction impedance in the conducting substrate below the nanoporous layer through which significant current flows at ac. Further this peak is only dependent on the specific antigen concentration and is not perturbed by the interfering species of blood. This enables selective detection of Hep-B virus in blood samples down to 1 fM concentration. Similar effect has been reported for food toxin detection [11] but there is no report with blood samples.

For a point of care device, a handheld electronic interface has also been designed with a sensor drive circuit and a RMS value generator circuit. It generates the different frequencies automatically, computes the sensitivity at different frequency and displays the virus concentration in a LCD after matching the peak frequency with look up table. The proposed system demonstrates a point of care device based on impedance spectroscopy for ultrasensitive Hep-B detection.

II. MATERIALS AND METHODS

A. Fabrication of Nanocrystalline Porous Silicon

For fabrication of nanoporous silicon, p-type <100> silicon wafers of resistivity 10-20 Ωcm were cleaned by standard procedure and then etched anodically in a double pond electrochemical bath with an electrolytic mixture of hydrofluoric acid (48 wt%) and dimethyl sulfoxide in the ratio 1:9 by volume. Etching an area of 1.6 cm^2 was carried out under a constant current source of 2.35 mA for 30 minutes to

N. Das, N. Samanta, L. Pandey, and C. Roy Chaudhuri are with the Electronics and Telecommunication Department, Indian Institute of Engineering Science and Technology(IIST), Shibpur, Howrah-711103 (e-mail: narentitun@gmail.com, samanta.nir.ind@gmail.com, liton.pandey@gmail.com, chirosreepam@yahoo.com).

obtain pores of thickness of about 100 nm and diameter of about 250 nm.

B. Thermal Oxidation and Metallization

Dry thermal oxidation has been done in an oxidation furnace at 1000 °C for 3 hours and 90 minutes to obtain oxide thickness of 0.05 μm.

For metallization, metal electrodes of high temperature silver paste have been fabricated using screen printing technique and then cured at 750°C for 1 minute. After that, gold metal is evaporated on silver.

C. Surface Functionalization and Antibody Immobilization

For surface functionalization [12], the oxidized samples were treated with sulphochromic acid for 10 minutes followed by treatment with hydroxylated silane (MTS) on dancing shaker for 1 hour. Next, samples were incubated at 95°C and then treated with cross-linker 2 mM GMBS. Finally anti-HBsAg antibody was immobilized.

D. Blood Sample Preparation

The target protein used is HBsAg (1 mg/ml) which is purchased from US Biological, USA. For calibrated measurements, serial dilutions of this HBsAg solution were made with PBS to yield HBsAg solution of concentrations are 1fg/ml and 1pg/ml. The blood sample is kept for some time to separate the serum. Then different concentration of Hep-B surface antigen has been spiked in serum sample in the range of 1fg/ml to 1pg/ml.

E. Signal Processing

The basic requirements of the signal processing unit are:

- Automatic generation of different frequencies of simulation waveform in the range of 125Hz to 52 KHz.
- User selectable switches to indicate the control and test reading.
- LCD interface for display of virus concentration.

In the signal generation part a signal generator chip ICL8038 by Intersil Corporation has been introduced. It has a wide frequency range from 0.001Hz to 300 KHz and operates with a ±5V power source. The frequency values between 125 Hz - 52 KHz are generated by tuning the capacitance values with five MOS switches of Texas Instruments- TPS2023. A voltage divider circuit has been introduced at the output of the signal generator chip to control the amplitude of sinusoidal wave within 50mV.

The signal generator is followed by a sensor drive circuit. The sensor drive circuit has been designed with an operational amplifier in non-inverting mode. The operational amplifier used is low noise, low offset and low power OP07. The bandwidth, noise and offset voltage are 600 kHz, 600nV and around 75μV respectively which are sufficient for our scheme. The passive components used are low temperature coefficient precision metal film resistors and polyester capacitors to ensure stability of the waveforms. The output of the sensor drive circuit is sinusoidal in nature and hence before directly interfacing with the built-in ADC of the microcontroller, the output is first interfaced with a true RMS generating chip AD737. But the output voltage of AD737 is negative so an inverting amplifier is used.

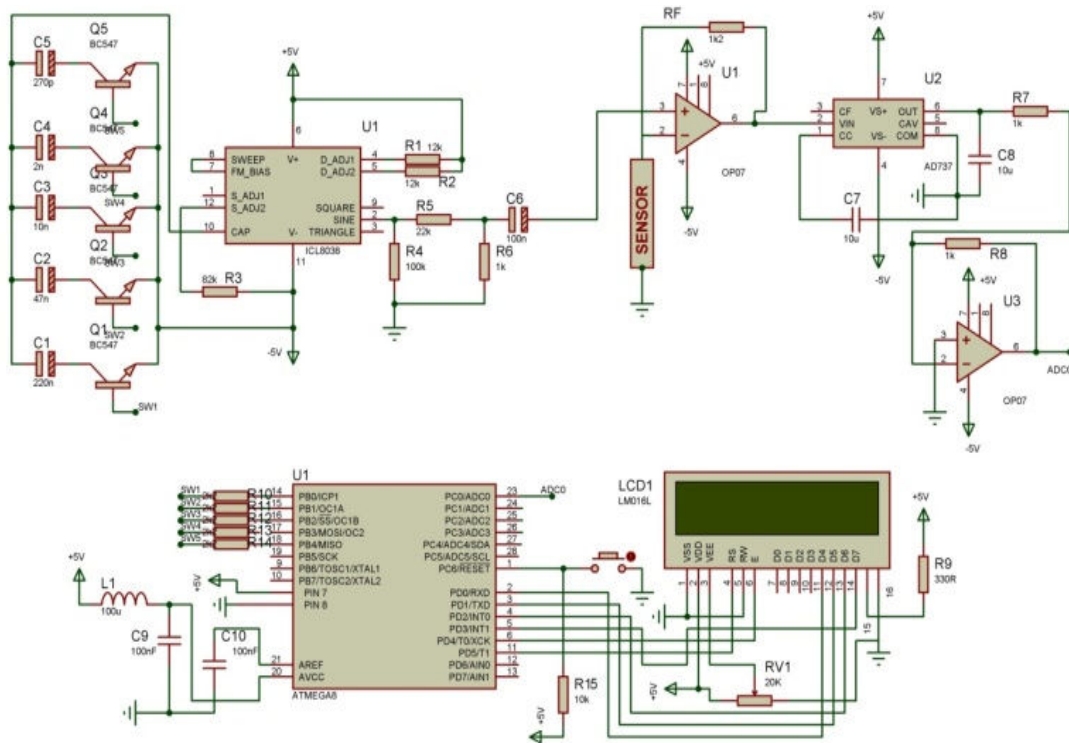

Fig. 1 Schematic of signal processing unit

The microcontroller used in this system is ATMEGA8. It is a low-power ATMEGA 8-bit AVR RISC-based microcontroller which combines 8KB of programmable flash memory, 1KB of SRAM, 512K EEPROM, and an 8 channel 10-bit A/D converter. The device supports throughput of 16 MIPS at 16 MHz and operates between 2.7-5.5 volts. The MOS switches are controlled from the microcontroller ports for tuning the capacitance values. A 16X2 alphanumeric LCD by WINSTAR has been attached with the controller ports to display the output result. The total schematic of the electronic interface is shown in Fig. 1. In the software part of the system microcontroller is programmed with an intelligent algorithm. The program is written in simple BASIC language with BASCOM AVR compiler.

III. RESULT AND DISCUSSION

A. Characterization

Biosensor surface morphology was characterized by scanning electron microscopy (SEM). Fig. 2 (a) shows a SEM image of oxidized nanocrystalline porous silicon. The antibody immobilization can be observed by a change in surface topology to a speckled, grainy image shown in Fig. 2 (b). Each of the speckles represents clusters of protein on the surface of the silanized nanoporous silicon. The surface topography shows good definition of antibody particle binding with sensor surface.

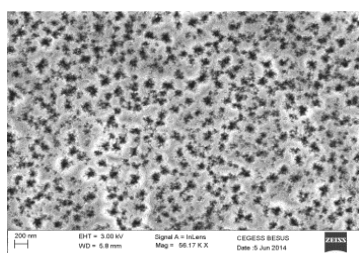

Fig. 2 (a) SEM image of oxidized nanoporous silicon

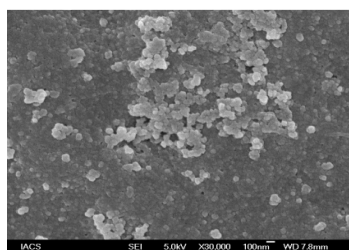

Fig. 2 (b) SEM image of antibody coated nanoporous silicon oxide

B. Impedance Measurements

After the immobilization of monoclonal antibodies for HBsAg, impedance spectroscopy measurements have been carried out with the help of LCR meter (GW INSTEK LCR 821) with a 50mV amplitude signal varying from 62.5 Hz to 100 kHz. Before measurement with every HBsAg concentration spiked in serum, a control measurement with PBS is done to establish the reference impedance. The serum containing HBsAg is then directly pipetted onto the sensor

without the requirement of any pre-concentration or centrifugation. To ensure repeatability of measurements, a well like structure has been fabricated on polydimethylsiloxane (PDMS) sheets and bonded with the surface of the sensor with a plasma treatment. The solution required to fill up the well is around 30 μ l. The picture of the sensor is shown in Fig. 3. The variation in impedance with frequency before and after capture of HBsAg molecules with concentration of 1 fg/ml is shown in Fig. 4.

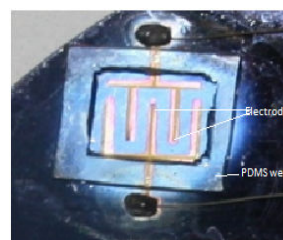

Fig. 3 Final view of the sensor

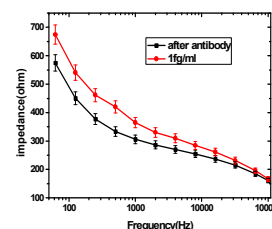

Fig. 4 Variation in impedance with frequency before and after 1fg/ml HBsAg molecules

Fig. 5 shows the percentage change in impedance commonly termed as sensitivity with frequency for different HBsAg concentration and a serum solution without HBsAg. It is observed that sensitivity is more with increasing concentration which is very obvious. But the interesting feature is that the maximum change occurs at different frequencies for different HBsAg concentration. Usually in most of the reported impedance biosensors the sensitivity gradually decreases, increases, or remains almost constant with frequency. In this case, we observe that the shift of the peak frequency is quite significant with HBsAg concentration. The percentage change in impedance is around 25% for 1 fg/ml and around 61% for 1 ng/ml which is only two and half times but the peak frequency shifts from 500Hz to 16 kHz for the same change in concentration and hence is significantly less susceptible to noise.

C. Measurement with Electronic Interface

In the signal generator different frequency values are generated by changing the capacitances. Some of the frequency values and the corresponding capacitance values are given in the Table I. Then the output sinusoidal wave has been used in the sensor drive circuit. When the signal passes through the sensor drive circuit the output signal will be phase shifted. The input and output waveform of sensor drive circuit has been shown in Fig. 6. The comparison of the peak

frequency obtained from the LCR meter and electronic interface is shown in Table II.

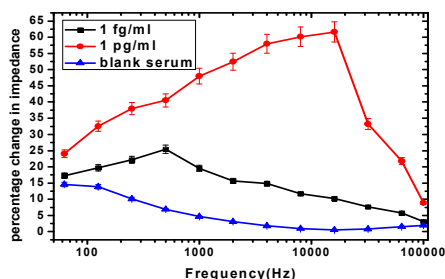

Fig. 5 Sensitivity for blank serum and different HBsAg concentration in serum

TABLE I
CAPACITANCE VALUES AND CORRESPONDING FREQUENCY VALUES
 $R_1=R_2=R=12K\Omega$

Output amplitude (p-p)mV	Capacitor value	Calculated frequency	Resultant frequency
95.65	$C_1=220nF$	125Hz	127Hz
95.65	$C_2=56nF$	491Hz	530Hz
95.65	$C_3=2nF$	13.75Khz	10.50Khz
95.65	$C_4=1.5nF$	16.17Khz	16Khz
95.65	$C_5=470nF$	55.89Khz	52Khz

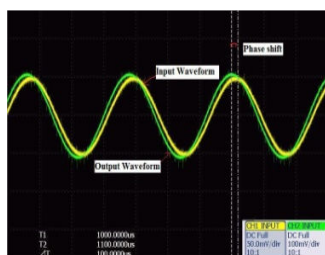

Fig. 6 (a) input and output waveform at 530 Hz

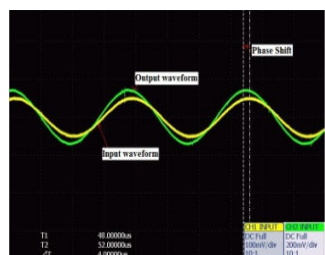

Fig. 6 (b) input and output waveform at 16.5 KHz

TABLE II
PEAK FREQUENCIES RECORDED BY LCR METER AND ELECTRONIC INTERFACE

HBsAg concentration	Peak frequency From LCR	Peak frequency from electronic interface
1fg/ml	500Hz	530Hz
10fg/ml	1Khz	1.25Khz
100fg/ml	8Khz	9.5Khz
1pg/ml	16Khz	16.5Khz

It is observed that the output of the electronic interface matches closely the LCR meter readings. Thus we have been

able to realize a complete portable system to quantify Hep-B virus in blood in trace quantities without the requirement of any centrifuge or other pre-concentration techniques. The complete picture of the packaged set up is shown in Fig. 7. The sensor device along with the electronic interface has the potential for deployment in point of care diagnostics.

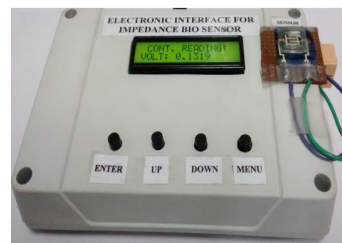

Fig. 7 Pictorial view of electronic interface

ACKNOWLEDGMENT

The authors would like to acknowledge Professor H. Saha of Center of Excellence of Green Energy and Sensor Systems, IEST, Shibpur for his help in oxidation. Financial support has been provided by UGC, DST-SEED and DST-WEA, Govt. of India.

REFERENCES

- Li Mei, Peng Wu, Jing Ye, Guangping Gao, Lin Shao, Shaomei Huang, Yaoming Li, Xiaohong Yang, Huanchun Chen, and Shengbo Cao, "Development and application of an antigen capture ELISA assay for diagnosis of Japanese encephalitis virus in swine, human and mosquito," *Virology Journal*, vol. 9: 4, 2012.
- Xue-Yong Huang, Xiao-Ning Hu, Hong Ma, Yan-Hua Du, Hong-Xia Ma, Kai Kang, Ai-Guo You, Hai-Feng Wang, Li Zhang, Hao-Min Chen, J. Stephen Dumler, and Bian-Li Xu, "Detection of New Bunyavirus RNA by Reverse Transcription-Loop-Mediated Isothermal Amplification," *J. clinical microbiology*, vol. 52, 2014, pp. 531-535.
- Yong-Hwan Choi, Ga-Yeon Lee, Hyuk Ko, Young Wook Chang, Min-Jung Kang, and Jae-Chul Pyun, "Development of SPR biosensor for the detection of human hepatitis B virus using plasma-treated parylene-N film," *Biosens. Bioelectron.*, vol. 56, 2014, pp. 286-294.
- Cuixia Ma, Mo Liang, Li Wang, Hua Xiang, Yingtao Jiang, Yiyan Li, and Guoming Xie, "MultisHRP-DNA-coated CMWNTs as signal labels for an ultrasensitive hepatitis C virus core antigen electrochemical immunosensor," *Biosens. Bioelectron.*, Vol. 47, 2013, pp. 467-474.
- Jee-Yeon Kim, Jae-Hyuk Ahn, Dong-II Moon, Tae Jung Park, Sang Yup Lee, and Yang-Kyu Choi, "Multiplex electrical detection of avian influenza and human immunodeficiency virus with an underlap-embedded silicon nanowire field-effect transistor," *Biosens. Bioelectron.*, vol. 55, 2014, pp. 162-167.
- Dawid Nidzworski, Paulina Pranszke, Magda Grudniewska, Ewelina Król, and Beata Gromadzka, "Universal biosensor for detection of influenza virus," *Biosens. Bioelectron.*, vol. 59, 2014, pp. 239-242.
- Thi Thanh Binh Nguyen, Guiwan Koh, Hui Si Lim, Anthony JS Chua, Mary M L Ng, and Chee Seng Toh, "Membrane-Based Electrochemical Nanobiosensor for the Detection of Virus," *Anal. Chem.*, vol. 81, 2009, pp. 7226-7234.
- Jiajia Deng and Chee-Seng Toh, "Impedimetric DNA Biosensor Based on a Nanoporous Alumina Membrane for the Detection of the Specific Oligonucleotide Sequence of Dengue Virus," *Sensors*, vol. 13, 2013, pp. 7774-7785.
- Gengfeng Zheng, Xuan P. A. Gao, and Charles M. Lieber, "Frequency Domain Detection of Biomolecules Using Silicon Nanowire Biosensors," *NanoLetts.*, vol. 10, 2010, pp. 3179-3183.
- Roberto de la Rica and Molly M. Stevens, "Plasmonic ELISA for the ultrasensitive detection of disease biomarkers with the naked eye," *Nat. Nanotech.*, vol. 7, 2012, pp. 821-824.

- [11] H. Ghosh and C. RoyChaudhuri, "Ultrasensitive food toxin biosensor using frequency based signals of silicon oxide nanoporous structure," *Appl. Phys. Lett.*, Vol. 102, 2013, pp. 243701.
- [12] R. Dev Das, S. Maji, S. Das, and C. RoyChaudhuri, "Optimization of covalent antibody immobilization on macroporous silicon solid supports," *Appl. Surface Sci.*, vol. 256, 2010, pp.5867-575.

N. Das received the master's degree, with specialization on Digital System & Instrumentation, from the Indian Institute of Engineering Science and Technology (IEST), Shibpur, Howrah-711103, in 2013. He is currently working toward the Ph.D. degree in electronics and telecommunication engineering, with specialization on Electrical Biosensor for virus detection, Department of Electronics and Telecommunication Engineering, IEST, Shibpur, Howrah, India.

N. Samanta received the M.Tech. degree in Electronics and Communication Engineering from the West Bengal University of Technology, West Bengal, India, in 2009. He is pursuing Ph.D research in Electronics and Telecommunication Engineering Department, IEST, Shibpur, India. His current research interests include the development of signal processing system for biosensors and sensor network for elderly health monitoring and signal processing of electrical biosensors.

L.Pandey received the B.Tech degree in Applied Electronics & Instrumentation Engineering from West Bengal University of Technology, Kolkata, India. He is pursuing his ME in Electronics and telecommunication engineering from IEST, Shibpur, Howrah, India. His working area is Biosensor signal processing.

Chirasree Roy Chaudhuri has completed her PhD in 2007 from Jadavpur University, India and is presently an Assistant professor in Department of Electronics and Telecomm. Engg., IEST Shibpur, India. Her fields of research interest are development of selective electrical biosensors, understanding the physical mechanisms for sub-femtomolar detection and measurement of biophysical properties of cells through distributed models. She has received the Young Scientist Award from National Academy of Science, India and Women Excellence Award from Department of Science and Technology, Govt. of India and has published around 60 papers in peer reviewed journals and proceedings.