

Networked Radar System to Increase Safety of Urban Railroad Crossing

S. Saponara, L. Fanucci, R. Cassettari, P. Ruggiero, M. Righetto

Abstract—The paper presents an innovative networked radar system for detection of obstacles in a railway level crossing scenario. This Monitoring System (MS) is able to detect moving or still obstacles within the railway level crossing area automatically, avoiding the need of human presence for surveillance. The MS is also connected to the National Railway Information and Signaling System to communicate in real-time the level crossing status. The architecture is compliant with the highest Safety Integrity Level (SIL4) of the CENELEC standard. The number of radar sensors used is configurable at set-up time and depends on how large the level crossing area can be. At least two sensors are expected and up four can be used for larger areas. The whole processing chain that elaborates the output sensor signals, as well as the communication interface, is fully-digital, was designed in VHDL code and implemented onto a Xilinx Virtex 6.

Keywords—Radar for safe mobility, railroad crossing, railway, transport safety.

I. INTRODUCTION

A Big challenge in transport systems is to increase the safety of railway level crossing, particularly in urban scenarios. In railway level crossing, automatic control systems have been massively introduced to cut the cost of having people for the surveillance of each railroad crossing. However severe incidents can occur due to: i) a fault in the automatic system closing/opening the gates; ii) a fault in the automatic system signaling the transit of trains; iii) the incorrect behaviour of pedestrians, drivers and bikers who get trapped in the crossing thus representing an obstacle for the incoming train. As an example, as reported in [1]-[3], accidents at level crossing in Indian railways are accounting for 49% of total fatalities in railway transport during the last decade. Severe accidents often occur in case the railway is crossing at the same level a road in urban scenarios, particularly in big cities when, due to traffic congestion, cars, two- or three-wheeled vehicles (motorcycles, bikes, rickshaws.....) or large trucks, are unable to leave the crossing during the train transit.

At physical level, this scenario is complicated by the fact that the Railroad crossing control system should work in severe environmental and light conditions, night and day, with a high Safety Integrity Level (SIL) as defined in the CENELEC European Standards. A new networked system, based on radar sensors and on a SIL4 architecture, is presented in this paper. Our system improves the safety in the railway

level crossing systems enabling the transit of trains only when the level crossing is free from obstacles and improves the traffic conditions giving additional information to the drivers through electronic panels (e.g. railway crossing status, accidents).

The paper is organized as follows. In Section II is described the architecture at system level. The following Section presents the radar sensor technology focusing on the constraints on a radar sensor for this kind of application. The signal processing chain designed for detecting obstacles within railway level crossing area is described in Section IV. Section V presents the system implementation and the results obtained. Finally the conclusions are drawn in Section VI.

II. ARCHITECTURE OF THE NETWORKED RADAR SYSTEM

To address this issue we proposed, designed and tested a scalable Monitoring System (MS) in which several Nodes, each placed inside one of the level crossings along the railway network, automatically monitor the state of the level crossing itself, without the need for a human operator. The MS is connected to multiple Remote Stations used as operator interfaces displaced on the territory. Each Node consists of a Radar sub-system and a Processing sub-system and implements a SIL4 architecture which is the highest Safety Integrity Level defined by the CENELEC standards. Fig. 1 shows an example of MS with one single Node and one single Remote Station. The Processing sub-system tasks are to configure the Radar sensors, to verify the integrity and congruency of their output and to communicate the relevant information on the state of the node to the Railway Signaling System and to the Remote Station. For each level crossing up to four Radar sensors are used, depending on its size. Each Radar sensor independently detects moving or still obstacles placed inside a configurable area measuring up to 250m² and passes this information to the Processing sub-system together with additional diagnostic information regarding the sensor and the level crossing. The Remote Station collects the data from the whole network of Nodes showing in a simple and user friendly interface the macroscopic state of each Node (presence or absence of obstacles, open or closed barriers, possible failures on the monitoring system) and, at the same time, building up a record of detailed additional information to be examined in case of need. Also, the Remote Station is connected to the Traffic Management System delivering additional information to drivers about the state of the level crossings in real-time. The Railway Signaling System, based on the information from the MS, enables the transit of incoming trains in each of the level crossings only if the

S. Saponara, L. Fanucci and R. Cassettari are with the Dept. of Information Engineering, University of Pisa, Pisa, Italy.

P. Ruggiero and M. Righetto are with IDS S.p.A., Pisa, Italy (e-mail: m.righetto@idscorporation.com).

specific Node decides on the absence of obstacles inside the level crossing area.

In the following section the Radar sensor and its design are

described. A special detail is given to its data processing section which is the most innovative part of the system.

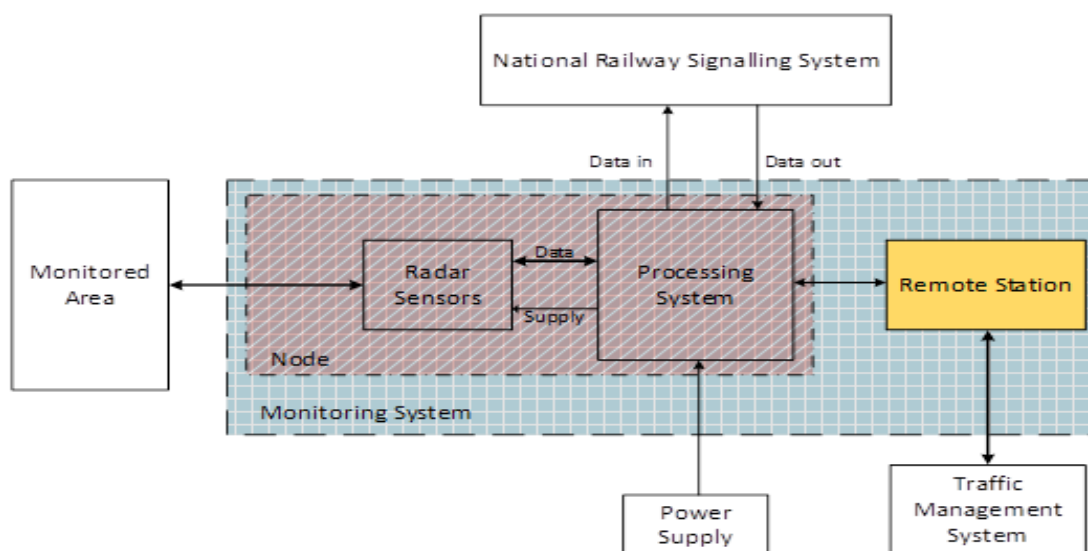

Fig. 1 System architecture

III. THE RADAR SENSOR

Radar technology, especially in the X-band which is in the range from 8 GHz to 12 GHz, is preferable to other competing imaging technologies like videocamera, ultrasounds or LIDAR because of the following:

- In a short-range (less than 50m) application, radar is much less sensitive to weather conditions than its competitors, allowing for a safe detection of obstacles during heavy rain, snow and hail, in presence of dense fog, strong sun glares and environmental noises and vibrations.
- Since in a safe system sensitivity to weather conditions strongly affects availability, a radar system will also reduce delays in the rail network system promptly delivering accurate information on the absence of obstacles (which occurs most of the time) in the level crossing when a train is approaching.

In a radar system detection and classification of a target is based on its Radar Cross Section (RCS), which is a measure of the power of the electromagnetic wave reflected by the target towards the radar receiver with respect to the incident power from the radar transmitter. The RCS for a target of a given size and shape is very strong for targets made of conductive materials or very dense materials like stone and wood but drops quickly as the target density lowers.

This behaviour allows for a low false alarm rate in a radar system due to extensive but very low-density objects (potentially not dangerous) like plastic bags, paper sheets or empty cardboard boxes, further improving availability.

Radar technology is also preferable to other non-imaging technologies such as induction loops and photoelectric or radio-frequency interruption beam sensors because of its relatively small size compared to the level crossing area and its ease of installation, setup, use and maintenance. All those

reasons are strong grounds for the use of radar technology in a level crossing monitoring system.

A. Radar Design

The following aspects were considered in the design process of the Radar sensor:

1. Sensor Dimensions

Sensor dimensions should be limited to a tenth of m^3 or less due to environmental constraints such as the proximity of the road, the railway and its infrastructures. Small dimensions also mean low installation and maintenance costs.

2. Target Dimensions

The typical target to be detected is a vehicle or an obstacle that could cause damage to the train and harm the passengers on it; people on the level crossing are to be detected too because their lives are at risk. For such targets the relevant materials are metal, wood, stone, heavy plastic materials and organic materials.

3. Target Speed and Range

Vehicles, people and other obstacles can either be still or moving up to few tens of km/h. Small level crossings measure less than $100 m^2$ hence a Radar sensor covering a maximum range of 25 meters would be enough. It should be possible to use more than one sensor for level crossings with larger dimensions.

4. Weather Conditions

The monitoring system has to work in a wide range of environmental conditions such as different light conditions (night and day), with rain or fog or snow, in a large range of temperature from $-20^{\circ}C$ to $70^{\circ}C$. The system must ensure safety and show very good availability throughout the year

and the territory in virtually every possible environmental and weather condition.

Table I reports the main Radar sensor specifications. The radar working frequency was chosen within the X band as a tradeoff among sensor/antenna dimensions, working bandwidth, resolution, range of use and effect of the weather conditions. A remarkable effect of such choice is that, for short ranges, rainfall, snowfall and fog cause negligible drawbacks on the target detection function of the Radar sensor because the chosen Electromagnetic (EM) wavelength is much bigger than the water droplets and ice crystals involved in such weather phenomena [4]. This was analysed and independently verified both on effects regarding the EM signal attenuation and on effects regarding spurious EM signal clutter generation due to weather conditions [4], [5].

In order to keep the power consumption low and considering the short-range application, we designed a Linear Frequency Modulated Continuous Wave (LFMCW) sensor. LFMCW radars are preferred respect to pulsed radar when, as in this application, is important acquire information about the speed of the target [6]-[9]. This solution allows for a lower transmission peak power with respect to a pulsed radar working with the same Signal to Noise Ratio (SNR), reducing costs, dimensions and power consumption with an improved reliability and a low impact on people, environment and other electronic devices from an EM point of view.

Both range and azimuth resolutions were chosen matching typical vehicles and obstacles dimensions, in order to optimize SNR, and to avoid false alarms due to vehicles and people moving outside the level crossing barriers. Range and azimuth resolutions, measuring respectively about 30cm and 2 degrees, are obtained by means of a 500MHz bandwidth transceiver and a 45cm wide patch antennas array.

TABLE I
 RADAR SENSOR MAIN FEATURES

Waveform	LFMCW	Max range	25 m
Central frequency	9.5 GHz	Sensor size	60x30x20 cm
Range resolution	~30 cm	Power	<50W
Azimuth resolution	~2 deg.	Temp. range	-20°C to 70°C

IV. THE DATA PROCESSING SECTION OF THE PROPOSED RADAR SENSOR

The output of the radar sensor analog section is a baseband double channel (In phase + Quadrature: IQ) signal containing both information about the monitored area (Obstacle Detection function) and the sensor working parameters (Diagnostic function). Such signal is digitally converted by means of a 24bit dual-channel Analog to Digital Converter and processed by the processing section of the Radar sensor in order to automatically detect possible obstacles inside the observation area and to diagnose possible sensor faults. The processing chain can be divided in two main functions: the Obstacle Detection function, further divided in six main sub-processing units:

- Data Gain Calibration
- 2-D Focalization and multiple observation areas,

- STI filtering and first level detection,
- MTI filtering and first level detection,
- M/N second level detection
- Decision Logics and the Diagnostic function.

The following sub-sections describe in detail each of these sections.

A. Data Gain Calibration

This sub-processing section has the purpose to calibrate the radar signal in order to increase the robustness of the system to temperature variations that occur during its functioning.

B. 2-D Focalization and Multiple Observation Areas

In order to use the data deriving from the sampling of the baseband converted received chirp a 2D-Focus operation is needed which transforms the data from a frequency/array-channel domain to a range-azimuth domain. The output is an electromagnetic photography of the area of interest (the level crossing). This transformation is performed exploiting the Fast Fourier Transform (FFT) algorithm first along the frequency domain and then along the antenna array channels domain. Since the characteristics of a railway level crossing are not standardized and the topology can vary a lot from one to another and since the position of possible obstacles is important in defining if it is a hazard for incoming trains, an algorithm has been developed to select only the portion of interest of the whole image. Sub-portions of the whole image can be defined in order to apply different thresholds and algorithms to different areas based on their relative position with respect to railway tracks and barriers.

C. STI Filtering and First Level Detection

The STI (Still Target Indicator) sub-processing unit has the objective to detect still obstacles on the area of interest. This unit is implemented by a low pass FIR filter applied to multiple 2-D focalized images. The STI first level detection occurs when the current integrated and filtered focalized image is greater than a configurable threshold.

D. MTI Filtering and First Level Detection

The MTI (Moving Target Indicator) sub-processing unit has the objective to detect moving obstacles on the area of interest. This unit is implemented by a high pass FIR filter applied to multiple 2-D focalized images.

The filter removes unwanted low doppler components from the image and exploits the well-known *doppler* effect: in fact, targets with different velocities, will give receiving signals at different frequency. The MTI first level detection occurs when the current filtered image has a power greater than the configurable threshold.

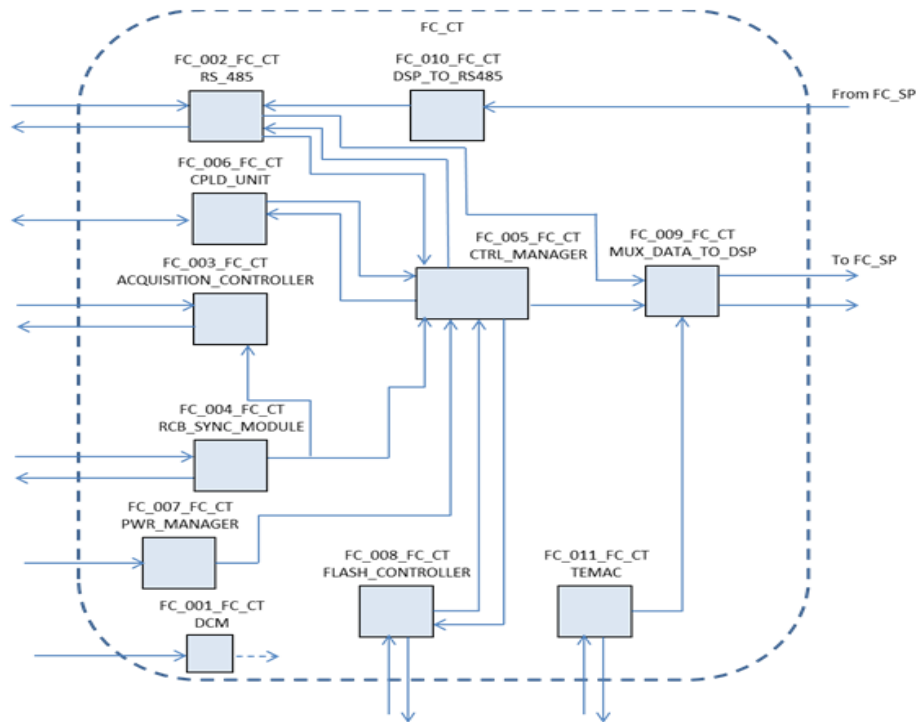

Fig. 1 FPGA Control Module block diagram

E. M/N Second Level Detection

This unit implements the moving window detection logic of the radar system used to reduce the false alarm probability given a target detection probability granting at the same time a low response time when actually an obstacle is present on the rails. The unit counts the number of the first level detections revealed by the MTI and STI units and signals the actual presence of an obstacle only if M first level detections occurred in the last N measurements.

F. Decision Logics

Depending on the result of the second level detection, the decision logics control the behaviour of the diagnostics units.

G. Diagnostics Function

FTA (Fault Tree Analysis) and FMEA (Failure Mode and Effects Analysis) were performed to the system to ensure the SIL level. As a result of this analysis, risks mitigation techniques were introduced in the processing chain. To detect the faults that can occur in the system, the diagnostics units have the purpose to detect malfunctioning of the analog electronics, measuring gain and noise, reveal physical obstructions of the antennas, measuring the power of the coupling signal, and check the focalization functionality, using a reference target, part of the system, and continuously checking its presence.

V. IMPLEMENTATION AND RESULTS

With respect to traditional DSP architecture for the signal processing algorithm implementation, all the processing chain has been implemented with a single FPGA which furthermore manages the low level HW interfaces of the system. This HW

solution was preferred to a possible software (SW) solution because of the real-time constraints together with the huge amount of calculations required by some processing algorithms such as FFT. To implement the calibration sub-processing unit, a special loopback path has been implemented inside the sensor. The transmitted signal is routed through this path and sent back to be received, once digitalized, by the FPGA to perform the calibration operation as the antenna signal is received and to perform the diagnostics function. The processing algorithm has been first prototyped in Matlab environment and then translated in HDL language. The resulting design has been synthesized, placed and routed on a Xilinx Virtex 6 FPGA, model XC6VSX315T-1FFG1156I. The occupation of the design was optimized and is rather low on the selected device, thus it can also be implemented on a Xilinx Spartan 6 FPGA to reduce costs.

The FPGA Design can be divided in a control module and in a processing module. The control module manages the low level interfaces of the FPGA on the digital board while the processing module implements the signal and data processing chain described in Section IV. Fig. 2 shows the control module block diagram, while Fig. 3 shows the processing module.

The control module implements the interfaces of the FPGA with the onboard 24-bit ADCs through the ACQUISITION_CONTROLLER module and starts the waveform generation through the CPLD_UNIT module. The communication with the external equipment is managed by the RS_485 module. This interface was selected due to its robustness to external interference. An ethernet interface has also been implemented for test purposes. This interface allows

the stimulation of the processing module with ADC data previously acquired. The control module also implements a unit to write and read from an on-board FLASH. This allows for the storage of relevant processing intermediate outputs in a non-volatile memory, used to reload such data when needed (for example when restoring from blackouts). All the Control Module functionalities are managed by the CTRL_MANAGER unit.

The first elaboration on the received signal, once it has been sampled, is the PRE_PROCESSING. This unit basically counts the input samples and routes them to the rest of the processing. Furthermore, this unit checks the coherency of the installation parameters, coming from the RS_485 module and provides the thresholds to the STI and MTI modules.

CALIB_OFFSET_GAIN module implements the calibration operation, described in Section IV.

The FFT_2D_CELL_SELECTION module implements the 2D-Focalization and the selection of the pixels that belong to the areas of interest. The FFT algorithm was designed exploiting the Xilinx FFT IP.

RO_STI_PROC implements the STI processing, filtering the focalized images, calculating the current background and checking the current image against the reference background to signal first level STI detections. BACKGROUND_MNG, controlled by the DECISION_LOGIC, stores the current calculated background in a circular buffer and provides the old background to the STI processing for the first level detection.

RO_MTI_PROC implements the MTI processing, filtering the focalized images and detecting moving target on the

observed areas. The DETECTION module implements the M/N second level detection logics and synthesizes the results coming from RO_STI_PROC and RO_MTI_PROC providing second level detections to the DECISION_LOGIC. This last module builds the message to be sent to the RS_485 module containing the synthetic result of the processing and controls the behavior of the BACKGROUND_MNG. The DIAGNOSTICS module implements the logics to diagnose system faults and activates diagnostics signals to be sent to the RS_485 module.

CENELEC-EN50128 guidelines for the development and test of safety critical software used in railway applications have been considered for the FPGA Design. This includes the execution of simulations with statement and branch coverage besides static code analysis using automatic tools and synthesis flow verification (“diversity” applied on FPGA designs), ensuring the achievement of the required SIL.

As example, Fig. 4 shows a sequence of 4 images got after the focus and the first level decision processing, where a car is detected.

The clock frequency of the DSP block was 66.666 MHz, which meets the real-time requirements of the application. This value was chosen considering the maximum achievable frequency by the block, that was 73 MHz and the available clock frequencies from the Xilinx Digital Clock Manager (DCM) starting from the 100 MHz master clock input frequency.

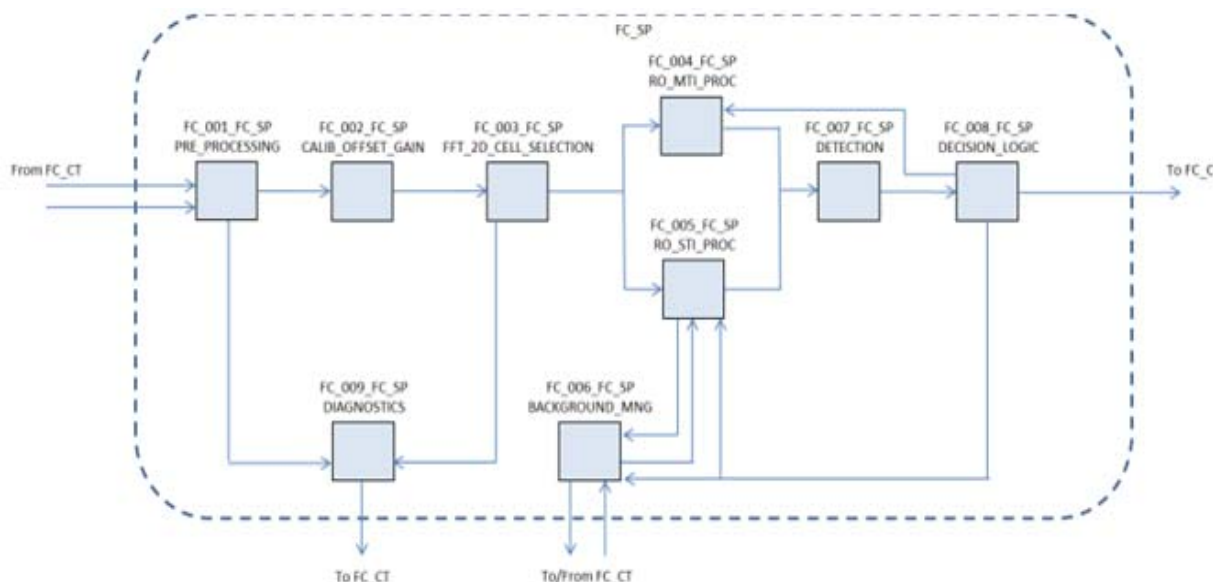

Fig. 3 FPGA Processing Module block diagram

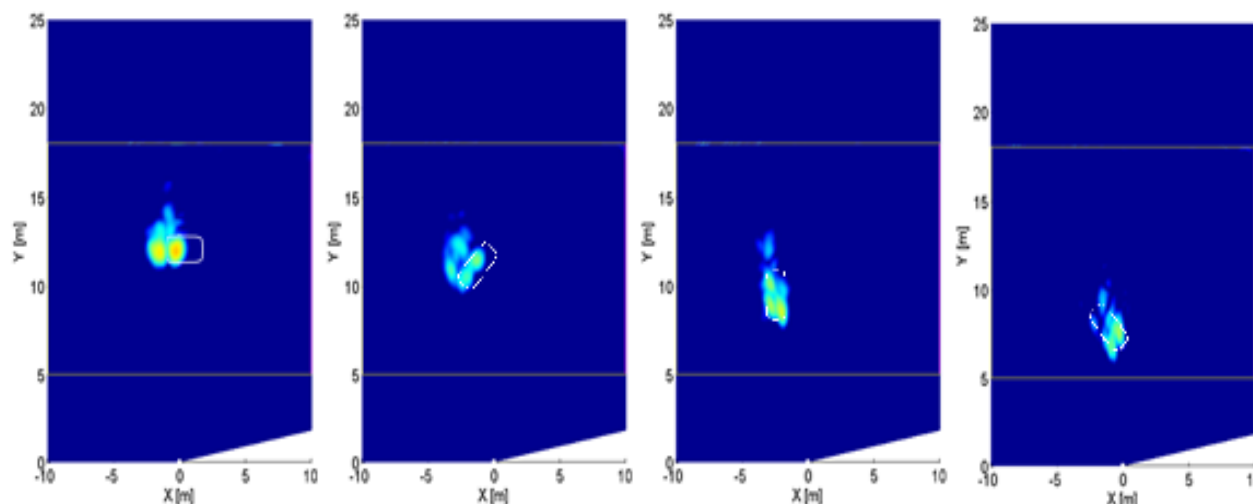

Fig. 4 Example of a car detected through the radar image while is moving in the railroad crossing

TABLE II
 SYNTHESIS RESULT

Slices (%)	LUTs (%)	Registers (%)	RAM Blocks (%)	DSP48 (%)
50	48	19	59	52

Table II summarizes the synthesis result on the selected FPGA.

VI. CONCLUSIONS

We presented a low-cost FPGA platform on a Radar sensor used to detect the presence of obstacles on railway level crossings. This Radar sensor is part of a scalable networked Monitoring System designed to increase the safety level of railway level crossings, which is of particular interest in urban scenarios to avoid severe accidents. The basic Node of the networked system, implementing a SIL4 architecture and designed and developed according to applicable CENELEC standards, detects both still and moving obstacles and estimates their size, density and position, thus also their potential danger. The presented system is connected to the National Railway Train Information and Signaling System. The whole radar processing chain, which detects dangerous objects within the level crossing area, is fully digital and it was described in Very high scale integrated circuit Hardware Description Language (VHDL) and implemented on the FPGA Xilinx Virtex 6, model XC6VSX315T-1FFG1156I. As further development, the information inferred by such Monitoring System could also be integrated with other information (i.e. traffic lights status, accidents) in order to suggest alternative paths and improve the viability.

ACKNOWLEDGMENT

The authors thank Regione Toscana for the economic support of the "SIMPLE" project within the POR CreO FESR 2007/2013 initiative.

REFERENCES

- [1] R. Ramchadran, "FPGA based SOC for railway level crossing management system," *International Journal of Soft Computing and Engineering (IJSCE)*, vol. 2-3, pp. 134–137, 2012.
- [2] P. V. K. D. Yugandhar, "An enhanced railway transport system using FPGA through GPS & GSM," *International Journal of Soft Computing and Engineering (IJSCE)*, vol. 2-6, pp. 185–188, January 2013.
- [3] A. Tsiftsis, G. C. Sirakoulis, and J. Lygouras, "FPGA design of a cellular automaton model for railway traffic flow with GPS module," *Lecture Notes in Computer Science*, vol. 6530, pp. 373–384, 2010.
- [4] F. Tampieri and C. Tomasi, "Size distribution models of fog and cloud droplets and their volume extinction coefficients at visible and infrared wavelengths," *PAGEOPH*, vol. 114, no. 4, pp. 571–586, 1976.
- [5] M. Skolnik, *Introduction to Radar Systems*, 3rd ed., N. York, Ed. McGraw-hill, 2001.
- [6] S. Lhomeier, "Development of an ultra-wideband radar system for vehicle detection at railway crossings," in *IEEE Conference on Ultra Wideband Systems and Technologies*, 20002.
- [7] T. Horimatsu, "ITS sensor for railroad crossing safety," *Fujitsu Sci. Tech. Journal*, vol. 43-2, pp. 220–226, 2007.
- [8] S. Saponara et al., *Highly Integrated Low Power Radars*, Artech, 2014.
- [9] B. Neri et al., "Advances in technologies, architectures, and applications of highly-integrated low-power radars " *IEEE Aerospace and Electronics Syst. Magazine* vol. 27, n.1, pp. 25-36, 2012.