

# Large Scale Production of Polyhydroxyalkanoates (PHAs) from Wastewater: A Study of Techno-Economics, Energy Use and Greenhouse Gas Emissions

Cora Fernandez Dacosta, John A. Posada, Andrea Ramirez

**Abstract**—The biodegradable family of polymers polyhydroxyalkanoates is an interesting substitute for convectional fossil-based plastics. However, the manufacturing and environmental impacts associated with their production via intracellular bacterial fermentation are strongly dependent on the raw material used and on energy consumption during the extraction process, limiting their potential for commercialization. Industrial wastewater is studied in this paper as a promising alternative feedstock for waste valorization. Based on results from laboratory and pilot-scale experiments, a conceptual process design, techno-economic analysis and life cycle assessment are developed for the large-scale production of the most common type of polyhydroxyalkanoate, polyhydroxybutyrate. Intracellular polyhydroxybutyrate is obtained via fermentation of microbial community present in industrial wastewater and the downstream processing is based on chemical digestion with surfactant and hypochlorite. The economic potential and environmental performance results help identifying bottlenecks and best opportunities to scale-up the process prior to industrial implementation. The outcome of this research indicates that the fermentation of wastewater towards PHB presents advantages compared to traditional PHAs production from sugars because the null environmental burdens and financial costs of the raw material in the bioplastic production process. Nevertheless, process optimization is still required to compete with the petrochemicals counterparts.

**Keywords**—Circular economy, life cycle assessment, polyhydroxyalkanoates, waste valorization.

## I. INTRODUCTION

**B**IO-BASED polymer production accounts only for 1.5% of the overall current polymer production capacity [1]. A crucial aspect in the shift from a petrochemical towards a bio-based economy is the development of a large-scale process to produce biodegradable alternatives to the conventional fossil-based polymers.

Polyhydroxyalkanoates (PHAs) is a family of polyesters which are an interesting potential substitute to traditional plastics because of their natural origin, biodegradability and functionality. Nevertheless, PHAs have high production costs, due to the energy required in the sterilization of the fermenters

This work was supported by the Dutch Foundation for Technical Sciences (STW) as part of 410 the Waste to Resource program (W2R project nr. 11605).

C. Fernandez Dacosta works at the Copernicus Institute of Utrecht University, Heidelberglaan 2, 3584 CS Utrecht, the Netherlands (corresponding author; Phone: +31 302537687; e-mail: C.FernandezDacosta@uu.nl).

J. A. Posada and A. Ramirez work at the Copernicus Institute of Utrecht University, Heidelberglaan 2, 3584 CS Utrecht, the Netherlands (e-mail: J.A.PosadaDucque@uu.nl, C.A.Ramirez@uu.nl).

[2], the PHA yield on the substrate, and the efficiency of the Down Stream Processing (DSP) [3] which has delayed their wide commercialization.

From an environmental point of view, their benefits with respect to fossil-based polymers are still questioned [4]. Glucose, methanol or acetic acid, are traditional substrates in PHA production from a pure culture. Because of the crop cultivation, these raw materials extensively contribute to the environmental impact of the overall production process [5].

The biotechnological process, based on microbial community engineering for PHA production, has been proposed as an alternative strategy to address the aforementioned problems [6]. Instead of traditional pure culture bacterial fermentation using expensive feedstock, the novel process is based on the selection of a population of a variety of microorganisms with an enhanced PHA producing capacity (77% dry weight), using mixed substrates present in wastewater. Costless substrates and non-aseptic process conditions are applied, thus reducing environmental impacts and production costs. The concept has been proven at laboratory and pilot-plant scale using wastewater from paper mill and food industry, respectively [7], [8]. However, a large scale process has not been developed yet.

Besides from issues related with fermentation, the intracellular PHA needs to be extracted in a competitive DSP to further enhance economics and sustainability. Chemical digestion with surfactant and hypochlorite is one of the most common procedures, yielding a final product with a purity of 98% and 86% of recovery [9].

In the present study, the techno-economic and environmental performance, represented as energy use and greenhouse emissions, of the industrial production of one of the most common types of PHA, polyhydroxybutyrate (PHB), are investigated in an ex-ante sustainability analysis. The assessment was comprised of the conceptual process design, techno-economic evaluation and environmental Life Cycle Assessment (LCA). Fermentation was carried out by mixed bacterial culture present in industrial wastewater. The process here developed integrates the wastewater treatment with PHB production. It is assumed that the water effluent produced is at the same quality standards of the existing wastewater treatment process. Therefore, the wastewater treatment costs can be accounted as economic credits and deducted from the total processing costs.

## II. PROCESS DESCRIPTION

### A. Fermentation

The fermentation process, as shown in Fig. 1 (a), is carried out in three consecutive fermenters. The first fermenter is the acidification reactor R-101, where the organic material present in the wastewater is converted into volatile fatty acids with a yield of 0.91 g COD/g COD (Table I, [7]).

TABLE I  
FERMENTATION CONDITIONS

Fermenter	Parameter	Value	Units
Acidification	CODout	26.3	kg/m <sup>3</sup>
	SRT	1	day
	Conversion	50	kgCOD/m <sup>3</sup> d
	Yield	0.91	gCOD/gCOD
Selection	SRT	1	day
	Cycle length	0.5	day
	OTRmax	0.5	kgCOD/m <sup>3</sup> h
	Yield	0.34	gX/gCOD
	qO <sub>2</sub>	1	gO <sub>2</sub> /gXh
Accumulation	Cycle length	0.5	day
	OTRmax	0.5	kgO <sub>2</sub> /m <sup>3</sup> h
	Yield	0.44	gPHA/gCOD

COD: Chemical Oxygen Demand  
SRT: Solids Retention Time  
OTR: Oxygen Transfer Efficiency  
qO<sub>2</sub>: Oxygen Uptake Rate

The second fermenter is the selector R-102. The selector is fed with a split fraction of the acidification product, which is rich in substrate and contains the amount of COD needed for the bacterial growth. The selector is a sequencing batch reactor, with a cycle length of 0.5 days and a solids retention time of 1 day. Therefore, in every batch one half of the selector volume is replaced, whereas the other half of the volume remains inside the fermenter. PHA producing bacteria are enriched with a yield of 0.34 g X/g COD, [8] while a maximal biomass concentration in the selector is maintained under 0.5 kg/m<sup>3</sup>, based on a biomass oxygen uptake rate (qO<sub>2</sub>) of 1 kg O<sub>2</sub>/m<sup>3</sup>h and a maximal oxygen transfer capacity (OTR<sub>max</sub>) of 0.5 kg/m<sup>3</sup>h, as observed in the laboratory. To avoid overpassing the maximal allowed biomass concentration, dilution water is also fed into the selector.

The third and last step of the fermentation is the fed-batch accumulation reactor R-103, where the content of intracellular PHB on biomass is maximized up to 70%wt [7], [8]. The accumulator is fed with the biomass rich replacement volume from the selector and the substrate rich remaining fraction from the acidification reactor. The maximal allowed substrate concentration is 0.25 kg/m<sup>3</sup> to avoid inhibition, thus, the acidification product is dosed continuously during the entire batch length. At the end of the batch, the accumulator reactor contains the replacement volume from the selector and the corresponding fraction from the acidification product with a total suspended solids (TSS) concentration of 2.7 kg TSS/m<sup>3</sup>. At the end of the cycle the solids settle down during 30 minutes to concentrate the product stream. The clarified fraction outflows via the top of the settler and is used as

dilution stream to the selector. The settled product flows through the buffer tank T-101 before is continuously fed to the DSP for the recovery of the intracellular PHB.

### B. Downstream Processing

Cell disruption by chemical digestion can be carried out using surfactant and hypochlorite [9], see Fig. 1 (b). In the reactor R-201, sodium dodecyl sulfate (SDS) solubilizes the non-PHB cell material (NPCM) present in the wastewater after the fermentation. A mass ratio of 3:1 SDS:NPCM, a temperature of 55°C, and a residence time of 15 minutes were identified as optimal conditions in the laboratory.

After 88% of the intracellular PHB is recovered in the SDS treatment [9], the next step is PHB concentration in the hydrocyclone C-201 and the centrifuge C-202. The liquid phase is rich in SDS and 80% of it is crystallized at 9°C in R-301 [10]. The second chemical treatment for further extraction of PHB is carried out at R-401, with the addition of hypochlorite (NaOCl. Mass ratio of 8:1 NaOCl:NPCM), during 10 minutes at 30°C. 95% of the remaining PHB is recovered in this step. Further PHB purification is done by counter current washing process with water to remove the impurities, which comprise 9% of the solid phase. 99% of the contaminants are removed after the treatment in two mixing tanks (M-501 and M-502) with 5 minutes of residence time each and two centrifuges (C-501 and C-502) in series. PHB is concentrated discharging extra water at centrifuge C-601 and in a last air drying step (D-601).

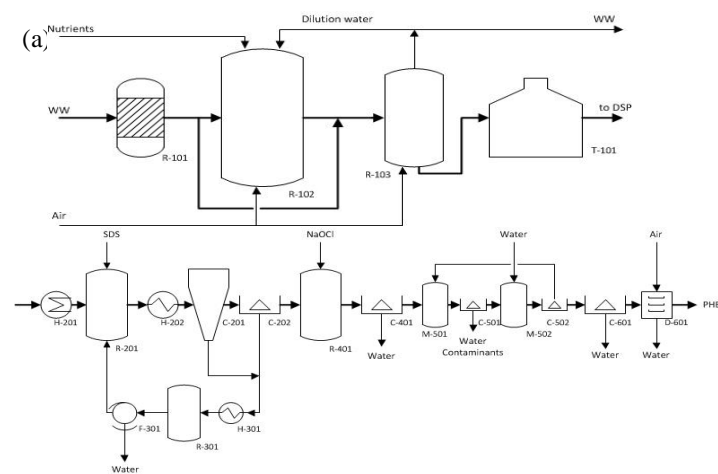

Fig. 1 Process flow diagrams: (a) Fermentation (b) DSP

## III. METHODS

### A. Process Design

Typically, PHB production capacity at industrial level ranges from 0.05 to 50 kt/a PHB [9]. In the waste-based PHA production process the availability of the raw material can limit the production of PHA at large scale. Depending on the waste streams used, the production capacity ranges between 1 to 5 kt PHA/a [6]. Based on the COD availability from wastewater, the production capacity in this study was fixed at 1.5 kt/a PHB, equal to 6.8 kt/a of COD demand in the

fermentation.

The conceptual process design of the operation units and mass and energy balances were based on process flowsheeting. Laboratory and pilot scale data [7], [8], were integrated with process modelling in ASPEN Plus software.

### B. Economic Evaluation

Total capital investment and material and energy consumption were calculated to analyze the economic potential of the designed process. The capital costs were estimated based on typical factors for delivered equipment costs [11], and the delivered equipment costs were estimated from correlations based on the characteristic size parameter of the equipment [12]. The costs were updated to 2013 prices with the Chemical Engineering Plant Cost Index (CEPCI). Annual depreciation ( $AD$ , see (1)) was calculated based on the total capital ( $f_i$ ) and the startup material costs ( $m_{SU}$ ). An interest rate ( $i$ ) of 5% and a payout time ( $POT$ ) of 20 years were assumed:

$$AD = (f_i + m_{SU}) \cdot \left[ \frac{i \cdot (1+i)^{POT}}{(1+i)^{POT} - 1} \right] \quad (1)$$

The utilities costs were estimated based on the energy consumption, from the energy balances, and assumed utilities unity costs [13]. Labor costs ( $L$ ) were assumed as 10% of the total annual costs ( $TAC$ ) and maintenance ( $M$ ) was assumed as 3% of the total fixed capital costs. Eventually, the total annual costs were composed by the annual depreciation, utilities, materials, maintenance, and labor costs as shown in (2):

$$TAC = AD + U + m + L + M \quad (2)$$

The otherwise required wastewater treatment (WWT) was assumed to provide credits to the PHB production process. The credits from the avoided treatment were estimated based on the wastewater flow and treatment costs [13]. No extra WWT expenses were included since the water discharged from the process was already treated in the upstream fermentation.

### C. Life Cycle Assessment

In order to address potential environmental impacts (energy use and greenhouse gas emissions) during the product lifetime, a LCA according to ISO 14040 and ISO 14044 standards [14], [15], and supported by EcoInvent 2.2 database was performed. The system boundaries were defined following a cradle-to-gate approach as shown in Fig. 2. The raw material industrial wastewater and the PHB production process were inside the system boundaries, whereas the product use and end-of-life treatment were outside the system boundaries. System expansion was applied to include the clean wastewater after the fermentation inside the system boundaries. The functional unit was 1 kilogram of PHB final product.

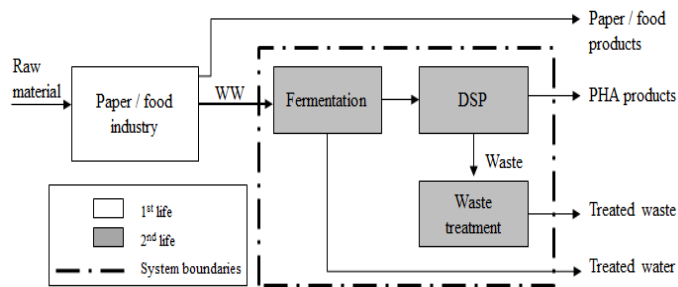

Fig. 2 System boundaries

After the system definition, the second phase of the LCA is the Life Cycle Inventory (LCI) including the input and output flows of material and energy from and to the environment. The inventory was derived from the mass and energy balances obtained in the conceptual process design and the models developed in ASPEN Plus. The inventory included the nutrients of the fermentation, the chemicals employed in the DSP, the utilities, and the waste treatment. Moreover, the avoided wastewater treatment and the biogenic carbon embodied in the final product were deducted from the gross energy use and greenhouse gas emissions, correspondingly [16], [17].

Following the inventory, the environmental impacts are assessed in the third phase of the LCA. The impact categories comprised in this study are the greenhouse gas emissions (GHG) and the non-renewable energy use (NREU). The individual impacts for the materials and energy carriers were taken from EcoInvent v2.2 database and combined with the normalized inventory provided the overall impacts for the entire process. The interpretation of the results is the last phase of the LCA and covers the conclusions, recommendations and identification of the process benefits and drawbacks.

### D. Sensitivity Analysis

The extraction efficiencies assumed in the process design for the chemical treatments with surfactant and hypochlorite were rather high, 88-95%, respectively. Although these values were based on laboratory experiments, in order to assess the robustness of the process against changes during the scale-up and practical implementation, additional case studies were investigated with reduced extraction efficiencies. The same approach and methodology as in the base case were followed to obtain economic and environmental results of the extra cases studied.

## IV. RESULTS AND DISCUSSION

### A. Process Design

A schematic flow diagram of the fermentation and DSP designed are shown in Fig. 1. The global PHB recovery yield was 75.8% with a final product purity of 99.9%wt. Temperatures higher than 65°C were avoided in the process design because they may cause PHB degradation [18]. Consequently, air drying for water evaporation was considered as an alternative processing step.

### B. Economic Evaluation

Based on the process conditions described in Section II and in the models and assumptions presented in Section III, the economic evaluation revealed total production costs of 1.56 €/kg PHB including fermentation, PHB extraction and the credits obtained from the avoided wastewater treatment. Results of the economic evaluation are depicted in Fig. 3.

The DSP related costs outweighed the costs of the fermentation, accounting for 73% of the total production costs. Considering the fermentation and DSP together, the major share of the total production costs were the utilities, 51% of the overall costs. Within the utilities, the steam costs, used for heating the fermenters were 12% of the total production costs. Cooling water after the SDS extraction had a share of 12% of the total production costs. Electricity, used in solid liquid separations, accounted for 11% of the total costs. The NaOCl and SDS materials used in the extraction showed the greater impact, after utilities, with 31% of the total costs.

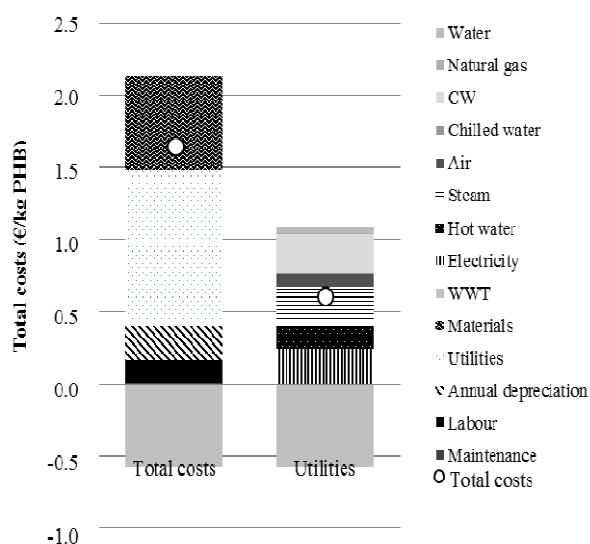

Fig. 3 Economic evaluation: Total production and utilities costs

The total production costs of the wastewater fermentation and DSP estimated in this study were lower than those of the scaled-up bacterial fermentation PHA process calculated in other studies. In Fig. 4 the results obtained in this study are compared with other literature references and industry data using different bacteria, raw material and DSP. The costs of traditional raw material for PHAs production such as glucose, sucrose or glycerol, can account for 23% of the total production costs [19]. A crucial aspect for the lower costs of the process designed in this study was the use of wastewater as feedstock for the mixed-culture bacterial fermentation, which provided credits instead of raw material related expenses. The credits, due to the avoided wastewater treatment, accounted for 27% of the total production costs.

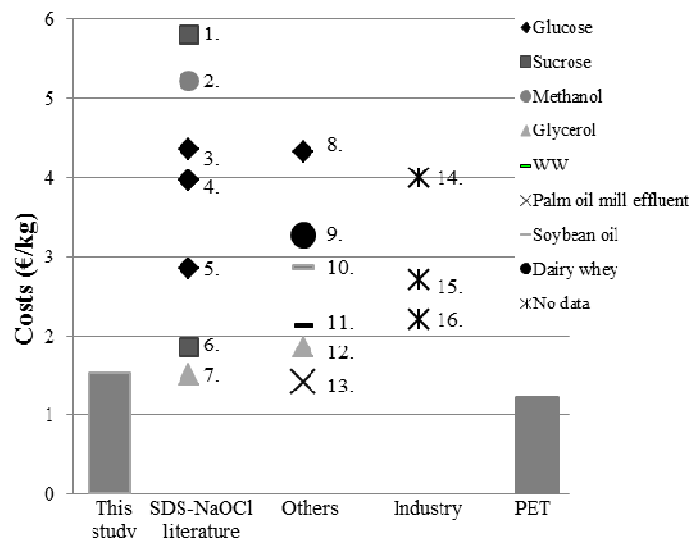

Fig. 4 PHAs production costs comparison to literature with different substrates and bacteria. 1. *A.latus*. 2. *M.organophilum*. 3. *E.coli*. 4. *A.entrophus* [20]; 5. *R.eutropha* [21]; 6. *A.latus* [22]; 7. *C.necator* [23]; 8,9. *E.coli* from [2]; 10. *R.eutropha* from [21]; 11. *Mixed culture* [24]; 12. *B.megaterium* [25]; 13. [26]; 14. Biomer Biotechnology Germany, 15. Biogreen Mitsubishi, Japan, 16. Biogreen Metabolix, USA [9]

Although PHB production costs from wastewater are lower compared to those for sugar-based production routes, the production costs still need to further decrease in order to become a competitive alternative to the petrochemical counterparts, such as polyethylene terephthalate (PET), which has a market price of 1.3 €/kg [27]. Furthermore, PET production process has been established for many years and has matured towards optimum conditions. PHB production via wastewater fermentation can largely be enhanced because the industrial process is still at a research and development stage.

### C. Life Cycle Assessment

A life cycle assessment was carried out for the PHB production via wastewater fermentation and for PHB extraction and purification via surfactant-hypochlorite chemical treatment. Table II shows the life cycle inventory (LCI), the GHG emissions and the NREU per kg of PHB produced.

The overall GHG emissions including fermentation and DSP, the credits from the avoided wastewater treatment and the biogenic carbon embedded in the PHB were 1.97 kg CO<sub>2</sub> eq/kg PHB. The NREU was 109 MJ/kg PHB. The environmental burdens of the fermentation were relatively low compared to the ones corresponding to the DSP. The GHG emissions of the DSP accounted for 60% of the total and the NREU of the DSP accounted for 72% of the total energy use. The outcome of the LCA is shown in Fig. 5. In the fermentation, the most important impacts, both in terms of GHG and NREU, were the steam and the nutrients. The steam was assumed as average production out of gas and heavy fuel oil. Steam impacts were taken from EcoInvent 2.2 information based on 11 European chemical producers. In the process designed, steam was used for heating the fermenters and

presented a 15% share of the total GHG emissions and 12% share of the total NREU. The fermentation nutrients were urea and phosphate, which accounted for 19% of the GHG and 15% of the overall NREU.

TABLE II  
LIFE CYCLE INVENTORY (LCI), GHG EMISSIONS AND NREU PER KG PHB

Process input	LCI	Unit	Per kg PHB	
			GHG (kg CO <sub>2</sub> )	NREU (MJ)
Nutrients (urea)	0.24	kg	0.77	15.87
Nutrients (phosphate)	0.04	kg	0.11	2.09
Steam	3.02	kg	0.60	11.92
Electricity ferm.	1.36	MJ	0.23	4.01
Electricity DSP	7.75	MJ	1.48	22.96
Natural gas	30.83	MJ	0.13	32.37
Water	420.24	kg	0.00	0.04
SDS	0.38	kg	0.69	23.14
NaOCl	0.51	kg	0.43	8.31
WWT (avoided)	0.19	m <sup>3</sup>	-0.43	-12.17
Biogenic carbon	2.04	kg	-2.04	-
<b>TOTAL</b>			<b>1.97</b>	<b>108.54</b>

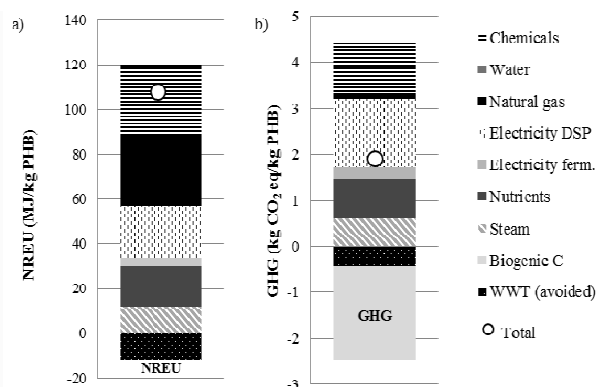

Fig. 5 LCA results: (a) NREU, (b) GHG emissions

The electricity was the DSP was the process input with the highest GHG emissions. It was assumed as medium voltage, produced in the Netherlands, at grid and mainly used in the solid-liquid separations and for cooling the required chilled water for crystallization in the recovery of SDS. The electricity related GHG emissions accounted for 33% of the global emissions and the NREU was 19% of the overall NREU.

Natural gas employed for dry and heat air and increase the temperature of fresh water had the highest share in the energy use, 27% of the total NREU. Air drying was used instead of steam drying to avoid high temperatures which affect the final product stability. The fresh water temperature was increased from 20°C to 80°C and used for pre-heating before the SDS treatment. Chemicals use related impacts were 25% and 26% of the overall GHG emissions and NREU, respectively.

The overall GHG emissions were in line with those associated with sugar-based PHA production (3 to 5 kg CO<sub>2</sub> eq/kg PHA, [28], [29]) and only 4% lower than analogous fossil based plastics (2.15 kg CO<sub>2</sub> eq/kg PET [30]). The NREU were around 35% higher than the values associated

with the sugar-based PHA (81 MJ/kg PHA, [28]) and 58% higher respect to PET production (69 MJ/kg PET [30]).

#### D. Sensitivity Analysis

The efficiency of the SDS-NaOCl chemical treatment assumed in the base case was based on experiments carried out in the laboratory. In the sensitivity analysis, the efficiencies of the surfactant and hypochlorite treatments were reduced by 10% and 20% with respect to the base case. Table III shows the results with reduced extraction efficiency in the chemical treatment.

Lower efficiency in the extraction steps results in lower amounts of PHB recovered from the cells fermented in the wastewater. Therefore, the unity costs (€/kg PHB) and the environmental impacts (GHG emissions and NREU per kg PHB) increased.

TABLE III  
SENSITIVITY ANALYSIS: REDUCED EXTRACTION EFFICIENCY

Efficiency	Base case	-10%	-20%	Units
Recovery	75.8	74.2	71.3	%
Depreciation	0.24	0.25	0.26	€/kg
Utilities	0.51	0.51	0.52	€/kg
Total costs	1.56	1.74	1.96	€/kg
GHG	2.06	2.28	2.60	kgCO <sub>2</sub> eq/kg
NREU	108	114	121	MJ/kg

With a decrease of 10% in both surfactant and hypochlorite treatment steps, the total production costs were 11% higher than in the base case. With 20% lower extraction efficiency; the total production costs increased 26%. From an environmental perspective, decrease 10% the efficiency, raised GHG emissions and NREU 11% and 5%, respectively; with 20% lower efficiency, the GHG emissions and NREU increased 26% and 11% respect to the base case.

#### V. CONCLUSION

PHB production from wastewater fermentation presents reduced costs and environmental impacts compared to traditional processes because of the credits provided by the avoided wastewater treatment. Moreover, there is a reduction in GHG emissions due to the biogenic carbon embodied in the final PHB product. The utilities of the DSP are the key contributor to the economics and sustainability. The designed process presents lower production costs and lower GHG emissions compared to the sugar-based PHB production. However, as compared with the optimized PET production process, PHB from wastewater process shows increased total production costs and NREU.

#### ACKNOWLEDGMENT

The authors wish to express their gratitude to dr. Yang Jiang, Jelmer Tamis (TU Delft) and dr. Gizela Mikova (TU Eindhoven) for providing the experimental data on which the process designs were based.

## REFERENCES

- [1] M. Carus, "Production capacities for bio-based polymers in Europe - status quo and trends towards 2020," *Nova-Institute for Ecology and Innovation*. Press release. July 2013.
- [2] R. J. Van Wegen, Y. Ling, and A. P. J. Middelberg, "Industrial production of polyhydroxyalkanoates using *Escherichia coli*: An economic analysis," *Chemical Engineering Research and Design*, vol. 76, pp. 417-426, March 1998.
- [3] C. S. K., Reddy, R. Ghai, Rashmi, and V. C. Kalia, "Polyhydroxyalkanoates: an overview," *Bioresource Technology*, vol. 87, pp. 137-146, April 2003.
- [4] R. A. J. Verlinden, D. J. Hill, M. A. Kenward, C. D. Williams, and I. Radecka, "Bacterial synthesis of biodegradable polyhydroxyalkanoates," *Journal of Applied Microbiology*, vol. 102, pp. 1437-1449, June 2007.
- [5] L. L. Madison, and G.W. Huisman, "Metabolic engineering of poly(3-hydroxyalkanoates): from DNA to plastic," *Microbiology and Molecular Biology Reviews*, vol. 63, pp. 21-53, March 1999.
- [6] H. Salehzadeh, and M. C. M. Van Loosdrecht, "Production of polyhydroxyalkanoates by mixed culture: recent trends and biotechnological importance," *Biotechnology Advances*, vol. 22, pp. 261-279, January 2004.
- [7] Y. Jiang, L. Marang, J. Tamis, M. C. M. van Loosdrecht, H. Dijkman, and R. Kleerebezem, "Waste to resource: Converting paper mill wastewater to bioplastic," *Water Research*, vol. 46, pp. 5517-5530, November 2012.
- [8] J. Tamis, L. Katlin, Y. Jiang, M. C. M. van Loosdrecht, and R. Kleerebezem, "Enrichment of *Plasticumulans acidivorans* at pilot-scale for PHA production on industrial wastewater," *Journal of Biotechnology*, to be published.
- [9] N. Jacquell, C.-W. Lo, Y.-H. Wei, H.-S. Wu, and S. S. Wang, "Isolation and purification of bacterial poly(3-hydroxyalkanoates)," *Biochemical Engineering Journal*, vol. 39, pp. 15-27, April 2008.
- [10] L. A. Smith, K. J. Roberts, D. Machin, and G. McLeod, "An examination of the solution phase and nucleation properties of sodium, potassium and rubidium dodecyl sulphates," *Journal of Crystal Growth*, vol. 226, pp. 158-167, June 2001.
- [11] R. Smith, *Chemical process design and integration*, pp. 17-31, Chichester: John Wiley & Sons, 2005.
- [12] R. K. Sinnott, *Coulson & Richardson's chemical engineering. Volume 6: chemical engineering design*, fourth ed., pp. 246-279, Oxford: Elsevier, 2005.
- [13] G. D. Ulrich, and P. T. Vasudevan, "How to estimate utility costs," *Chemical Engineering*, vol. 4, pp. 66-69, April 2006.
- [14] International Standards Organization (ISO), ISO 14040:2006, "Environmental management. Life cycle assessment. Principles and framework," 2006a.
- [15] International Standards Organization (ISO), ISO 14044:2006, "Environmental management. Life cycle assessment. Requirements and guidelines," 2006b.
- [16] U.S. Environmental Protection Agency, "Accounting framework for biogenic CO<sub>2</sub> emissions from stationary sources," Office of Atmospheric Programs, Climate Change Division, Washington, DC, 2011.
- [17] P. Pawelzik, M. Carus, J. Hotchkiss, R. Narayan, S. Selke, M. Wellisch, M. Weiss, B. Wicke, and M. K. Patel, "Critical aspects in the life cycle assessment (LCA) of bio-based materials—Reviewing methodologies and deriving recommendations," *Resources, Conservation and Recycling*, vol. 73, pp. 211-228, April 2013.
- [18] Y. Jiang, G. Mikova, R. Kleerebezem, L. A. M. van der Wielen, and M.C. Cuellar, "Feasibility study of an alkaline-based chemical treatment for polyhydroxyalkanoates purification from mixed enriched culture," unpublished.
- [19] D. Michael, "Biodegradable polymer supply chains: implications and opportunities for agriculture," Wondu Holdings, Sydney, 2004.
- [20] J. Choi, and S. Y. Lee, "Process analysis and economic evaluation for Poly(3-hydroxybutyrate) production by fermentation," *Bioprocess Engineering*, vol. 17, pp. 335-342, November 1997.
- [21] M. Akiyama, T. Tsugea, and Y. Doia, "Environmental life cycle comparison of polyhydroxyalkanoates produced from renewable carbon resources by bacterial fermentation," *Polymer Degradation and Stability*, vol. 80, pp. 183-194, February 2003.
- [22] S. Y. Lee, and J. Choi, "Effect of fermentation performance on the economics of poly(3-hydroxybutyrate) production by *Alcaligenes latus*," *Polymer Degradation and Stability*, vol. 59, pp. 387-393, January 1998.
- [23] J. A. Posada, J. M. Naranjo, J. A. López, J. C. Higuaita, and C. A. Cardona, "Design and analysis of poly-3-hydroxybutyrate production processes from crude glycerol," *Process Biochemistry*, vol. 46, pp. 310-317, January 2011.
- [24] N. Guriéff, and P. Lant, "Comparative life cycle assessment and financial analysis of mixed culture polyhydroxyalkanoate production," *Bioresource Technology*, vol. 98, pp. 3393-3403, July 2007.
- [25] J. M. Naranjo, J. A. Posada, J. C. Higuaita, and C. A. Cardona, "Valorization of glycerol through the production of biopolymers: The PHB case using *Bacillus megaterium*," *Bioresource Technology*, vol. 133, pp.38-44, April 2013.
- [26] T. Mumtaz, N. A. Yahaya, S.Abd-Aziz, N. A. Rahman, P. L. Yee, Y. Shirai, and M. A. Hassan, "Turning waste to wealth-biodegradable plastics polyhydroxyalkanoates from palm oil mill effluent - a Malaysian perspective," *Journal of Cleaner Production*, vol. 18, pp. 393-1402, June 2010.
- [27] ICIS Pricing. <http://www.icis.com/>
- [28] M. Patel, C. Bastioli, L. Marini, and E. Würdinger, "Life cycle assessment of bio-based polymers and natural fibres composites," *Biopolymers online*, vol.10, January 2005.
- [29] R. Briones, L. Tai, E. Daoud, and J. Hart, "Life Cycle Assessment. Identifying process improvement opportunities and assessing alternatives," California environmental protection agency department of toxic substances control, DTSC, Plastics Hazards Reduction Unit, June 2011.
- [30] A. Liebich, and J. Giegriech, "Eco-profiles of the European plastics industry. Polyethylene terephthalate (PET). Bottle grade," *Plastics Europe, Heidelberg*, April 2010.