

Design of Reconfigurable Parasitic Antenna for Single RF Chain MIMO Systems

C. Arunachalaperumal, B. Chandru, J. M. Mathana

Abstract— In recent years parasitic antenna play major role in MIMO systems because of their gain and spectral efficiency. In this paper, single RF chain MIMO transmitter is designed using reconfigurable parasitic antenna. The Spatial Modulation (SM) is a recently proposed scheme in MIMO scenario which activates only one antenna at a time. The SM entirely avoids ICI and IAS, and only requires a single RF chain at the transmitter. This would switch ON a single transmit-antenna for data transmission while all the other antennas are kept silent. The purpose of the parasitic elements is to change the radiation pattern of the radio waves which is emitted from the driven element and directing them in one direction and hence introduces transmit diversity. Diode is connect between the patch and ground by changing its state (ON and OFF) the parasitic element act as reflector and director and also capable of steering azimuth and elevation angle. This can be achieved by changing the input impedance of each parasitic element through single RF chain. The switching of diode would select the single parasitic antenna for spatial modulation. This antenna is expected to achieve maximum gain with desired efficiency.

Keywords—MIMO system, single RF chain, Parasitic Antenna.

I. INTRODUCTION

MORE than few decades many research papers has been published on conventional MIMO technology. The conventional MIMO link consists of a multi-antenna transmitter and a multi-antenna receiver. A full RF chain is assumed behind each antenna element, both on the transmitter and the receiver side, whereas a DSP is also assumed on each side of the link in order to pre-process or post-process jointly the baseband signals of all the antennas. The successful introduction of multi-antenna arrays in wireless networks of various types seems to hinge on the following issues/limitations 1) Need for multiple antennas at the base station for maximum sum rate , 2) Need for small/low cost antenna arrays at the access points, 3) Need for small/very low cost arrays, mainly for beamforming and battery saving. To overcome these limitations there are requirements of a single RF chains and requirements for much smaller inter-element distances. It is clear that if parasitic antenna arrays can be used that satisfy these two requirements [1].

Parasitic element is a conductive element, typically a metal rod or a patch, which is not electrically connected to anything

Arunachalaperumal. C., is with Anna University, Chennai, India as a Research Scholar & with S.A. Engineering College, Chennai, India as an Associate Professor (phone: +91-9486610552; e-mail: arunachalaperumal@sac.ac.in).

Chandru. B, Post Graduate Scholar, and Mathana. J.M., Professor, are with S.A. Engineering College, Chennai, India as a (e-mail: chandru91vi@gmail.com, drmathana@sac.ac.in).

else. The purpose of the parasitic elements is to modify the radiation pattern of the radio waves emitted by the driven element, directing them in a beam in one direction, increasing the antenna's directivity (gain). A parasitic element does this by acting as a passive resonator, absorbing the radio waves from the nearby driven element and re-radiating them again with a different phase. The waves from the different antenna elements interfere, strengthening the antenna's radiation in the desired direction, and cancelling out the waves in undesired directions.

II. ANTENNA DESIGN

In the conventional MIMO system, the data stream is feed to the spatial modulation and then to antenna selection and switches. According to antenna selection algorithm, antenna is selected and the particular antenna is switched ON remaining kept OFF which is shown in Fig. 1. In Fig. 2 the switches are replaced by the reconfigurable antenna which is capable of steering it beam according to the parasitic antenna selection.

The proposed antenna has been designed on 130mm square substrate for 5GHz. TLY5 is a substrate used. It is a composition of PTEE woven glass. The dielectric constant of Taconic TLY5 is 2.2 with dissipation factor of 0.0009 (tangent loss). The thermal conductivity of the Taconic substrate is 0.22W/m/K. and the thickness of the substrate is about 1.57mm with tolerance of +/- 0.02 (Taconic manual: TLY family of low loss materials [2]). Main radiator is a rectangular patch antenna and parasitic elements are circular patch antenna, which are surrounded to the main radiator is shown in Fig. 3. The resonance frequency of the antenna is given by $(f_r)_{110}$ for transmission line model rectangular patch [3]

$$(f_r)_{110} = \frac{v_0}{2L\sqrt{\epsilon_r}} \quad (1)$$

where L - length of the patch, ϵ_r is dielectric constant of the substrate. The length and width of the rectangular patch antenna is given as,

$$W = \frac{v_0}{2f_r} \sqrt{\frac{2}{\epsilon_r + 1}} \quad (2)$$

$$L = \frac{1}{2f_r \sqrt{\epsilon_{reff}} \sqrt{\mu_0 \epsilon_0}} - 2\Delta L \quad (3)$$

where ϵ_{reff} is effective dielectric constant which is calculated by,

$$\epsilon_{reff} = \frac{\epsilon_r + 1}{2} + \frac{\epsilon_r - 1}{2} \left[1 + 12 \frac{h}{W} \right]^{-1/2}$$

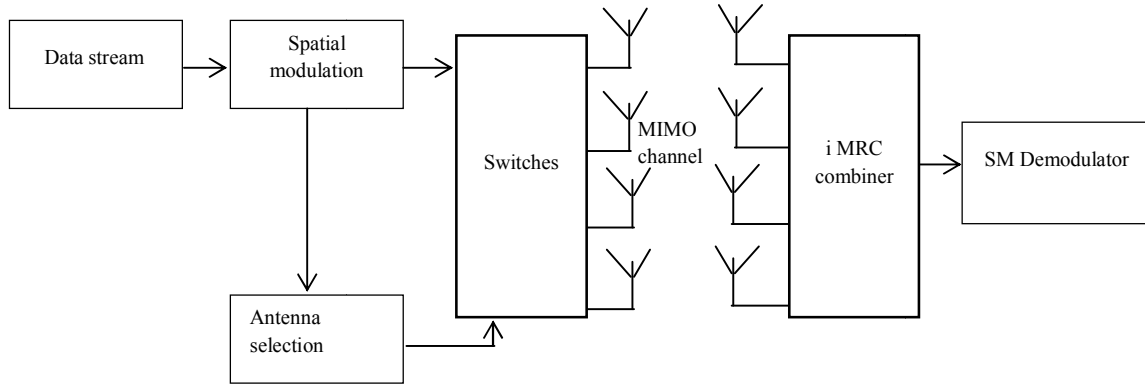

Fig. 1 Block diagram of conventional MIMO system

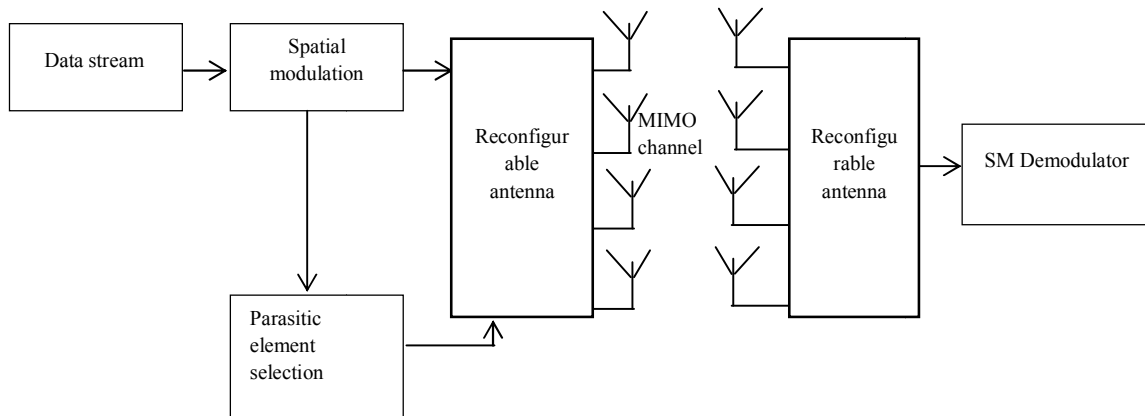

Fig. 2 Block diagram of MIMO model with Reconfigurable antenna

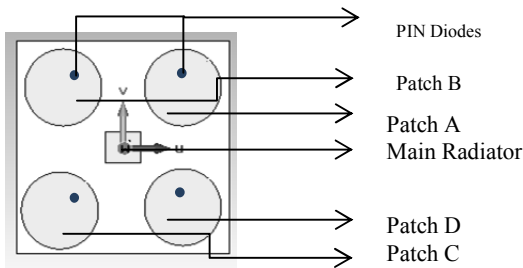

Fig. 3 Proposed antenna

The effective radius a_e and actual radius a for the circular patch parasitic elements are also given by [3]

$$a_e = a \left\{ 1 + \frac{2h}{\pi a \epsilon_r} \left[\ln \left(\frac{\pi a}{2h} \right) + 1.7726 \right] \right\}^{1/2} \quad (4)$$

$$a = \frac{F}{\left\{ 1 + \frac{2h}{\pi \epsilon_r F} \left[\ln \left(\frac{\pi F}{2h} \right) + 1.7726 \right] \right\}^{1/2}} \quad (5)$$

where

$$F = \frac{8.791 \times 10^9}{f_r \sqrt{\epsilon_r}} \quad (6)$$

The radiation pattern of the micro-strip antenna is referred in terms of E_θ and E_ϕ which is shown in (7), (8) respectively, given in [4].

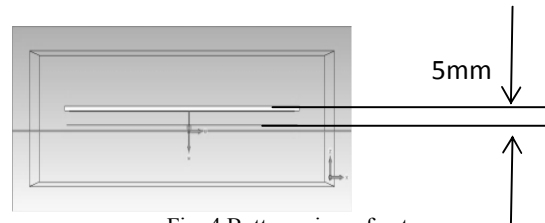

Fig. 4 Bottom view of antenna

$$E_\theta = -jV \frac{ak_0 e^{-jk_0 r}}{2r} \cos\phi J'_1(k_0 a \sin\theta) \quad (7)$$

$$E_\phi = jV \frac{ak_0 e^{-jk_0 r}}{2r} \frac{J_1(k_0 a \sin\theta)}{k_0 a \sin\theta} \cos\theta \sin\phi \quad (8)$$

The antenna ground plane influences the performance of these antennas. And the antenna design values are given as,

Length and Width of the rectangular main radiators = 22 and 19mm respectively.

Radius of all circular parasitic elements = 23.5mm

Fig. 4 shows that the gap between ground and substrate is given by 5mm.

After selecting the length and width of antenna and disk radius of circular parasites the next task is to determine the feed point. The input resistance for the TM_{11} mode can be expressed in [4].

$$R_{in} = R_r \sin^2(\pi X_f / L) \quad (9)$$

and the points for shorting pin are given in (10).

$$R_{in} = R_r \frac{J_1^2(k_{11} \rho_0)}{J_1^2(k_{11} a)} \quad (10)$$

TABLE I
 ANTENNA PARAMETERS

Substrate length and width	130mm ²
Length and width of radiating element	22 and 19mm
Radius of parasitic element	23.5mm
Gap between ground and substrate	5mm
Feed point	4mm in both x and y axes
Shorting pin points	23mm as radial
PIN diodes	4 (BAR 5002v)
Diode's (r, C) value	3 ~ 40Ω, 0.15pF

III. SPATIAL MULTIPLEXING WITH A SINGLE RF CHAIN AND PARASITIC ANTENNA SWITCHING

Here, four closely spaced parasitic antenna elements were considered, switched to a single RF chain. Each of the available parasitic elements is matched by impedance Z_M ; the array's admittance matrix can be expressed as Y [5].

$$Y = \begin{pmatrix} Z_M & 0 & 0 & 0 \\ 0 & Z_M & 0 & 0 \\ 0 & 0 & Z_M & 0 \\ 0 & 0 & 0 & Z_M \end{pmatrix} + \begin{pmatrix} Z_{11} & Z_{12} & Z_{13} & Z_{14} \\ Z_{21} & Z_{22} & Z_{23} & Z_{24} \\ Z_{31} & Z_{32} & Z_{33} & Z_{34} \\ Z_{41} & Z_{42} & Z_{43} & Z_{44} \end{pmatrix}^{-1} = \begin{pmatrix} Y_{11} & Y_{12} & Y_{13} & Y_{14} \\ Y_{21} & Y_{22} & Y_{23} & Y_{24} \\ Y_{31} & Y_{32} & Y_{33} & Y_{34} \\ Y_{41} & Y_{42} & Y_{43} & Y_{44} \end{pmatrix}$$

where Z_{ij} and Y_{ij} are the elements of the mutual impedance matrix and admittance matrix, respectively. The far-field of the antenna can be expressed as

$$P(\theta, \varphi) = P_{iso}(\theta, \varphi) Y v_s$$

where θ and φ are the elevation and azimuth observation angles, while $P_{iso}(\theta, \varphi) = [P_{iso,1}(\theta, \varphi) P_{iso,2}(\theta, \varphi) P_{iso,3}(\theta, \varphi) P_{iso,4}(\theta, \varphi)]$ is a vector with the isolated elements patterns (the pattern of each element when the other is open-circuited). This assumption implies that the open circuited antenna is a minimum scattered with respect to impedance parameter, and therefore, behaves almost exactly as if it were not present [7]. The vector v_s

contains the RF voltage signals. It can be verified that Y is a Toeplitz symmetric matrix. Considering the eigenvalue decomposition of Y, U will be a matrix the columns of which are the eigenvalue of Y , while L is a diagonal matrix with the corresponding eigenvalues.

$$P(\theta, \varphi) = P_{iso}(\theta, \varphi) U U^H v_s = B_T(\theta, \varphi) \tilde{v}$$

where $\tilde{v} = U^H v_s$ and $B_T(\theta, \varphi) = P_{iso}(\theta, \varphi) U U^H = [B_1(\theta, \varphi) B_2(\theta, \varphi) B_3(\theta, \varphi) B_4(\theta, \varphi)]$ are the basis patterns that compose the far-field radiation pattern $P(\theta, \varphi)$ [6].

IV. RESULTS

The proposed antenna using Taconic TLY 5 substrate is simulated in CST Microwave Studio Suite in which the antenna is resonating at 5 GHz frequency. Fig. 5 shows the S-parameter magnitude of the antenna. While changing the state of diodes which is shorting to ground from the parasitic elements, radiation pattern changes and angle of elevation and azimuth angle switches its direction. Fig. 6 shows the variation of radiation pattern according to elevation angle. Fig. 6 (a) shows the switching radiation pattern of an antenna while diode A, is in ON state. And also B, AC, BD in ON state is shown in Figs. 6 (b), (c), and (d) respectively.

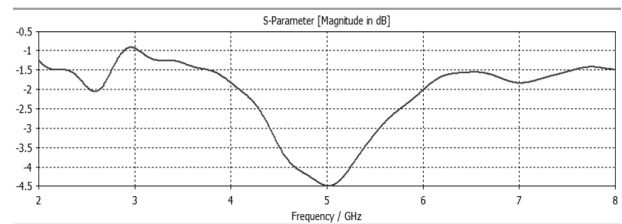

Fig. 5 S-parameter of proposed antenna

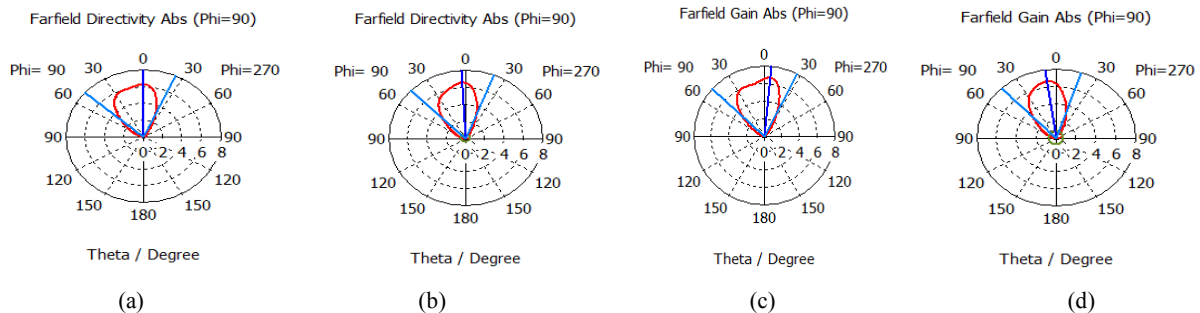

Fig. 6 Polar view of radiation pattern (a) diode A ON (b) diode B ON (c) diode A and C ON (d) diode B and D ON

Table II shows the switching angle of the antenna at resonating frequency of 5GHz with directivity and gain. The maximum gain is 7.160 dB and maximum directivity is 7.191 dBi. And the switching elevation angles are (0, 3, 6 and 8 deg.); azimuth angles are (11, 12, 150 and 14 deg.).

TABLE II
 ANTENNA INDEXING

Digital bits	Diode selected	Antenna selection	Elevation angle (deg.)	Azimuth angle (deg.)	Directivity (dBi)	Gain (dB)
00	A	Patch A	0	11	6.450	6.369
01	B	Patch B	3	12	6.674	6.605
10	A and C	Patch A and C	6	150	7.002	6.926
11	B and D	Patch B and D	8	14	7.191	7.160

V. CONCLUSION

After simulating the antenna with Taconic TLY 5 substrate and four parasitic elements with one main radiator and full of ground plane using CST Micro wave Studio Suite, it is concluded that the antenna is radiating efficiently at 5GHz. It is also discovered that the mutual coupling effect and parasitic element implementation contribute to the achievement of the beam-switching antenna at desired elevation angles (0, 3, 6 and 8) deg.; azimuth angles (11, 12, 150 and 14) deg. The reconfigurable beam-switching ability is developed using p-i-n diode switches. The maximum gain obtained during simulation is 7.160 dB and the maximum directivity is 7.191 dBi.

REFERENCE

- [1] Kalis. A. et al. (eds.), (2014), Parasitic Antenna Arrays for Wireless MIMO Systems, DOI 10.1007/978-1-4614-7999-4 2, © Springer Science+Business Media New York.
- [2] Taconic manual: TLY family of low loss materials, www.taconic-add.com/pdf/tly.pdf
- [3] Constantine. A.B. (2002), Antenna Theory Analysis and Design. NewYork, NY, USA: Wiley.
- [4] Bhartia. P, I. Bahl and A.I tipiboon, (2000) "Microstrip antenna design handbook", Artech House, Boston – London.
- [5] Fei. Y, Y. Fan, B.K. Lau, J. Thompson, (2008), "Optimal single-port matching impedance for capacity maximization in compact mimo arrays". IEEE Trans. Antennas Propag. 56(11), 3566–3575.
- [6] Alrabadi. O, C. Papadias, A. Kalis, N. Marchetti, R. Prasad, (2009) Spatial multiplexing via antenna switching. IEEE Commun. Lett. 13(8), 594–596.
- [7] Roscoe. A, R. Perrott, (1994), "Large finite array analysis using infinite array data". IEEE Trans. Antennas Propag. 42(7), 983–992.