

Apoptosis Pathway Targeted by Thymoquinone in MCF7 Breast Cancer Cell Line

M. Marjaneh, M. Y. Narazah, H. Shahrul

Abstract—Array-based gene expression analysis is a powerful tool to profile expression of genes and to generate information on therapeutic effects of new anti-cancer compounds. Anti-apoptotic effect of thymoquinone was studied in MCF7 breast cancer cell line using gene expression profiling with cDNA microarray. The purity and yield of RNA samples were determined using RNeasyPlus Mini kit. The Agilent RNA 6000 NanoLabChip kit evaluated the quantity of the RNA samples. AffinityScript RT oligo-dT promoter primer was used to generate cDNA strands. T7 RNA polymerase was used to convert cDNA to cRNA. The cRNA samples and human universal reference RNA were labelled with Cy-3-CTP and Cy-5-CTP, respectively. Feature Extraction and GeneSpring softwares analysed the data. The single experiment analysis revealed involvement of 64 pathways with up-regulated genes and 78 pathways with down-regulated genes. The MAPK and p38-MAPK pathways were inhibited due to the up-regulation of *PTPRR* gene. The inhibition of p38-MAPK suggested up-regulation of TGF- β pathway. Inhibition of p38-MAPK caused up-regulation of *TP53* and down-regulation of *Bcl2* genes indicating involvement of intrinsic apoptotic pathway. Down-regulation of *CARD16* gene as an adaptor molecule regulated CASP1 and suggested necrosis-like programmed cell death and involvement of caspase in apoptosis. Furthermore, down-regulation of GPCR, EGF-EGFR signalling pathways suggested reduction of ER. Involvement of AhR pathway which control cytochrome P450 and glucuronidation pathways showed metabolism of Thymoquinone. The findings showed differential expression of several genes in apoptosis pathways with thymoquinone treatment in estrogen receptor-positive breast cancer cells.

Keywords—CARD16, CASP10, cDNA microarray, PTPRR, Thymoquinone.

I. INTRODUCTION

WORLD incidence of breast cancer is increasing in parallel to the growth rate of population. According to the report by International Agency for Research on Cancer, the estimated incidence rate of breast cancer for women worldwide is about 22.9% and the estimated mortality rate is 13.7%. In recent years there have been many efforts on exploring prevention and treatment ways for breast cancer to rescue and increase survival years in women. Thymoquinone is known as an anti-neoplastic agent with an increasing literature on its medicinal properties over the years. Based on the previous studies, the postulated mechanism of Thymoquinone action involves multiple pathways which play

S.H. is with Advanced Medical and Dental Institute, Universiti Sains Malaysia, Penang, Malaysia (phone: 604-562-2012; fax: 604-562-2463; e-mail: shahrulbariyah@amdi.usm.edu.my).

N.M.Y. is with Advanced Medical and Dental Institute, Universiti Sains Malaysia, Penang, Malaysia (e-mail: Narazah@amdi.usm.edu.my).

M.M. is post graduate with Universiti Sains Malaysia (e-mail: marjaneh_motaghed@yahoo.com).

significant roles in cancer progression. It was reported that Thymoquinone trigger intrinsic pathways of apoptosis through the activation of caspase cascade. The activation of caspase-8 highlights the effect of Thymoquinone on *Bcl2* and the role of mitochondria in Thymoquinone-induced apoptosis in human squamous cell carcinoma [1], in human osteosarcoma p53-null MG63 cells [2] and in p53-null HL-60 Myeloblastic leukaemia [3]. The process of apoptosis in MCF7/DOX cells was also found to be mediated through a caspase-dependent manner which triggered the intrinsic pathway through the activation of caspas-3, -7, -9 and the cleavage of PARP but not caspase-8 [4]. Triggering of intrinsic pathways of apoptosis showed mitochondrial events which are not dependent on the *TP53* function [2], [3]. On the other hand, there was an increase of *TP53* expression level in MCF7/DOX cells [4] which indicated the p53-dependent apoptosis after treatment with Thymoquinone. The study on MCF7/DOX cell suggested the p53-dependent and p53-independent apoptosis due to the decrease level of Bcl2 protein and reduction in the Bcl2/Bax ratio [4]. The p53-induced apoptosis involves the MAPK pathway and regulation of Bcl2 protein family [2]. Increase in the expression level of *TP53* was reported in colorectal carcinoma cells [5], androgen-positive prostate cancer cells [6] and human osteosarcoma p53-mutant (MNNG/HOS) cells [2] along with decrease in the Bcl2/Bax ratio. Down-regulation of Bcl2 gene and procaspases 7, 8 and 9 in a concentration-dependent manner were reported due to the activation of cleavage process. Besides, inhibition of tumour cell growth via modulation of PPAR- γ pathway after the Thymoquinone treatment in MCF7 cell line [7]. In this study, in order to understand the apoptotic pathway of Thymoquinone it was tried to identify entire signalling pathways in MCF7 cell line after treatment using cDNA microarray analysis.

II. MATERIALS AND METHODS

A. Cell Line, Cell Culture and RNA Purity Analysis

The human mammary breast cancer epithelial cell line, MCF7 (HTB-22) was purchased from ATCC and harvested in RPMI 1640 (Invitrogen, Gibco, USA) medium containing L-glutamine supplemented with 10% heat-inactivated fetal bovine serum (Invitrogen, Gibco, USA) and 1 unit penicillin/streptomycin (Hyclon, USA). Cells were seeded at $3-4 \times 10^6$ counts and cultured with 5% CO₂ in a humidified incubator at 37°C (Thermo Scientific, USA) for 24 hours. The cells were treated with Thymoquinone 50 μ M concentration (Sigma-Aldrich, France) and the control cells with 0.05% DMSO alone. Samples of treated and untreated cells were from biological triplicates. RNA Isolation and quality control

assessment of total RNA were performed. The RNA samples were extracted according to the protocol of RNeasyPlus Mini kit (Qiagen, USA). The purity and yield of total RNA of each sample were obtained from NanoDrop 2000C Spectrophotometer (Thermo Scientific, USA). A ratio of approximately 2.0 is considered as pure for RNA samples. Hence, the samples with low $A_{260}/A_{230} < 2.0$ and $A_{260}/A_{280} < 1.8$ were excluded. The micro-channels of Agilent RNA 6000 NanoLabChip kit was used to evaluate the degree of degradation, quantity and integrity of the total RNA samples using Agilent 2100 Bioanalyzer instrument. The presence of two visible peaks related to 18S and 28S segments of ribosomal RNA on the electropherogram of micro-capillary electrophoresis obtained from Agilent 2100 bioanalyzer. The peak ratio of 28s:18s rRNA for treated samples was about 1.6 and for untreated samples was about 1.4 which indicated absence of RNA degradation and any contaminants.

B. Microarray Analysis

Whole-genome microarray was designed to identify the specific signalling pathways. Agilent's Low Input Quick Amp Labelling Kit was used to generate complementary RNA. Total RNA sample input from Thymoquinone-treated and untreated was 200 ng for 2-colour microarray analysis. AffinityScript RT oligo-dT promoter primer was used to add T-tail promoter primer to the poly A-tail of mRNA strand and made reverse transcription to produce 1st strand cDNA. The 2nd strand cDNA was obtained during amplification. The T7 RNA polymerase was used to make the cRNA from cDNA template and produced the labelled cRNAs. Reference design was done to label the cRNAs samples with Cy-3-CTP and the cRNAs human universal reference RNA with Cy-5-CTP. Then the labelled cRNAs were added to 2×GEx hybridization Buffer HI-RPM and centrifuged at 13,000 rpm in a micro-centrifuge (Kubota 3740, Japan) for 1 minute at room temperature. The components were loaded onto the array platform (8×60K) with SurePrint technology (Interscience, USA). Biological replicate of Thymoquinone-treated samples were placed in 4 different wells and this design repeated for untreated samples as well. The hybridization was done at 10 rpm and at 65°C for 17 hours. The hybridized array slide was washed according to the manufacturer's protocol and then placed into the scanner carousel with the ozone-barrier slide cover.

C. Quality Control Assessment on the Array and Entities

The profile Agilent G3_GX_2 Colour was used for the Scan Control program. The Agilent C Scanner converted the microarray file to the project. The data in .tiff image was converted into the .txt format using Feature Extraction software v10.7.3.1. LOWESS normalization reduced the dye bias. The data converted into digital values using GeneSpring software v12.1 and identified the pathway networks. Summarization of the raw signal values was reported by box whisker plot and then quality control on untreated and treated samples was done by Principal Component Analysis (PCA) to evaluate the reproducibility and reliability of the data. The

Quality control on entities was done by different filtering steps. The unpaired T-test was done on the entities to identify all differentially expressed genes with a p -value < 0.05 and the Benjamini Hochberg FDR reduced the false positive entities (genes). The total ratio of normalized intensities was calculated from the average intensities in all samples and reported as the fold change level of the genes. The identified genes were clustered based on the similarities or differences on their function and expression profile and the genes outside of the clusters were considered as outliers. The Pathway Architect imported all new pathways based on the Homo sapiens specific organism and removed the duplicate pathways. Then the pathway analysis was done based on the single experiment analysis (SEA).

III. RESULTS

The quality control reports showed the evaluation metric of all samples were in a good range except for sample of untreated 2 which indicated inadequate sample in well 2, non-specific hybridization, and/or insufficient washing step (Fig. 1). The quality control on samples showed that the PCA scores were in an acceptable range (Fig. 2). Total 42545 entities underwent different filtering steps and statistical analysis. The inhibition of MAPK signalling pathway due to the up-regulation of *PTPRR* gene is illustrated in diagram generated by GeneSpring software (Fig. 3).

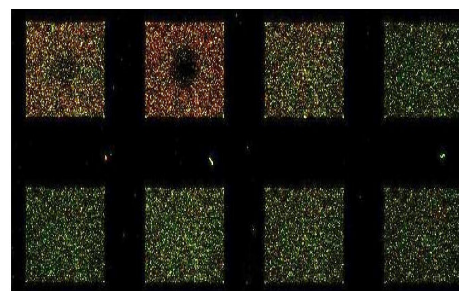

Fig. 1 Feature extraction software show image of arrays after hybridization

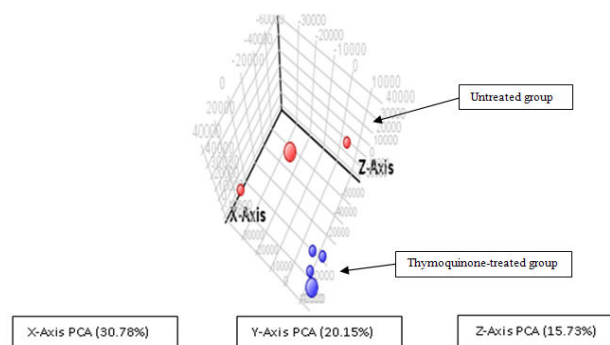

Fig. 2 Principal Component Analysis (PCA) scores showed on the 3D scatter plot using GeneSpring software version 12.1

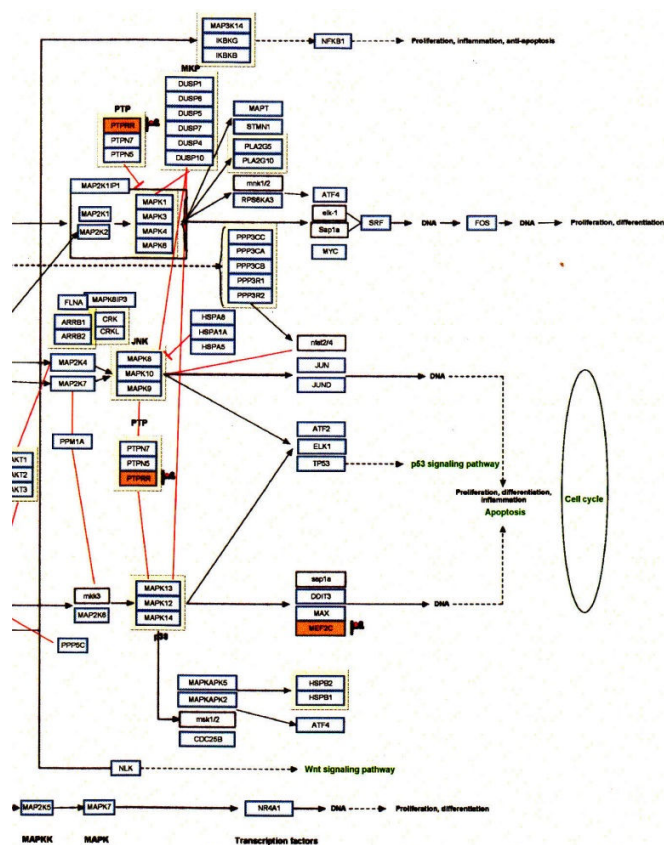

Fig. 3 Thymoquinone mechanism of action through MAPK pathway

IV. DISCUSSION

Breast cancer has been leading cause of mortality among women. Anti-cancer effects of Thymoquinone were reported through flow cytometry, Western Blot analysis, immunohistochemistry and multi-colour fluorescence in situ hybridization. Gene expression profiling is a tool to determine genes which are specifically targeted by Thymoquinone and illuminates the potential therapeutic targets.

There is an opinion of probability of the overlapping different cell death pathways targeted at a specific time. The multiple death pathways can protect the cells against the development of cancer [8]. Previous studies showed that anti-cancer effect of Thymoquinone on different type of cancer cells through *in vitro* and *in vivo* studies which indicate the involvement of Thymoquinone in different cell death signalling pathways including apoptosis, proliferation, angiogenesis and tumour induced immunosuppression. In current study, single experiment analysis (SEA) was done to identify gene expression modulated by thymoquinone in apoptosis pathway.

The up-regulation of *PTPRR* gene (2.20 fold) was noted and it would affect the signalling pathways of MAPK which include MAPK1, MAPK3, MAPK4, and MAPK6. This would potentially lead to the inhibition of transcription factor *FOS* which is involved in cell proliferation inhibition. Besides, the up-regulation of *PTPRR* gene inhibited p38-MAPK pathway (MAPK12, MAPK13, and MAPK14) and lead to the up-regulation of *MEF2C* (2.22 fold) and *TP53* genes (1.59 fold)

which trigger apoptosis. The up-regulation of MAPK8 (1.80 fold) and *TP53* genes (1.59 fold) suggest involvement of JNK pathway which is involved in apoptosis due to stress stimuli. Moreover, previous studies reported that phosphorylation of p38-MAPK occurs in approximately 20% of primary breast cancers and it is highly expressed in invasive breast tumours [9] and in pancreatic cancer cells [10]. Phosphorylation of p38-MAPK can also be involved in the proliferation of cells and tumour genesis. It is suggested that there is a contributory relationship between p38-MAPK activity and the rate of apoptosis due to the *TP53* phosphorylation in breast cancer cells [11]. The blockade of p38-MAP kinase signalling could inhibit the proliferation of some breast tumours (ER-/*TP53*mut) [9]. According to Genetic Home References 2014, the role of tumour suppressor protein p53 is important in the fate of cells because of its direct binding to DNA in the nucleus of cells. Therefore, it can control repair of damaged DNA by other genes, or else prevents the cells from dividing and leads to apoptosis. Thereby, it prevents the development of tumour formation. Mutations in the *TP53* gene are one of the important risks of breast cancer. Inherited (less than 1%) and somatic mutations (40%) of *TP53* gene are reported in all breast cancer cases.

Down-regulation of *Bcl2* gene (-1.80 fold) along with the up-regulation of *TP53* genes (1.59 fold) were noted. These findings need to be confirmed with gene silencing and protein analysis. The up-regulation of *CARD16* which is an adaptor molecule by 5.25 fold was also noted in this study. It is reported to be involved in the regulation of CASP1 in inflammation [12]. The CASP1 also plays an important role in pathological cell death or necrosis-like programmed cell death with unknown mechanism [13], [14], hence involvement of Thymoquinone in necrosis-like programmed cell death would be possible. In addition, Thymoquinone also caused the up-regulation of one of the initiator caspases (CASP10) by 1.57 fold [15]. Previously, the interaction of CASP10 with FADD or death-effector domain was reported [16]. There are two main apoptotic pathways which are the extrinsic and intrinsic pathway. Both pathways utilize the caspase enzyme cascade [17]. Taken together, these findings suggested the involvement of intrinsic pathway (mitochondrial pathway) and extrinsic pathway in MCF7 breast cancer cell line after Thymoquinone treatment. Every type of cell can secrete TGF- β while its function is dependent on the cell response to the TGF- β receptors [18]. Increase or decrease in the function of the TGF- β and its downstream pathway can lead to cancer. In fact, TGF- β show a dual or branched role in cancer cells. Its function in epithelial cells is known as a tumour suppressor which inhibits the proliferation of cells to cause apoptosis [18] and as an anti-proliferative signal in early tumour cells through the control of extracellular signals which move the cells into a quiescence stage or arrest [19]. The down-regulation of the TGF- β pathway is reported in various tumours [19]. The secretion of TGF- β was reported after inhibition of p38-MAPK pathways in metastatic pancreatic cancer cell lines by Thymoquinone treatment which led to apoptosis [10]. In the current study, an up-regulation of the

TGF- β pathway was seen after Thymoquinone treatment which would be due to the inhibition of p38-MAPK pathway. Previous research findings showed that the tumour suppressor *cav-1* gene is able to inactivate MAPK, causes low expression of ER α and decreases the cyclin D1 expression [20]-[22]. The down-regulation or loss of *cav-1* gene expression is reported in lung, breast, colon and ovarian carcinoma cell lines [21]. Taken together, in the current study the up-regulation of *cav-1* gene by 1.53 fold after the Thymoquinone treatment suggested the ability of Thymoquinone to increase the expression of *cav-1* gene and potentially inactivation of MAPK pathway. This would potentially cause a reduction in the level of ER α and cyclin D1. However, further investigation need to be done to confirm these findings.

Current study showed down-regulation of GPCR and EGF-EGFR signalling pathways. The growth factor signalling pathways triggers kinase cascades which causes the activation of ER. The EGF-EGFR is an important pathway which leads to the phosphorylation of ER. This causes over-expression of both ER and EGFR which leads to breast cancer growth [23]. Furthermore, the interaction between Thymoquinone and GPCR pathway was previously reported in mouse derived macrophage cells [24]. In addition, positive interaction between GPR30 and ER α are reported in MCF7 cell line [25] and in ovarian cancer cells [26]. It is postulated that Thymoquinone potentially causes ER to transmit signal via GPCR and EGFR [8]. Hence, down-regulation of GPCR and EGF-EGFR signalling pathways would cause reduction of ER which is highly expressed in luminal A sub-type MCF7 breast cancer cell line. Thymoquinone exhibits an anti-proliferative effect on hormone-dependent cancer [27].

V.CONCLUSION

To date different cell signalling pathways have been reported to trigger apoptosis pathway due to Thymoquinone treatment in various types of cancer. This study provide further information on specific gene expression changes in apoptosis pathway in Thymoquinone-treated MCF7 breast cancer cell line using whole-genome microarray analysis. The finding also showed involvement of EGF-EGFR, GPCR, MAPK, p38-MAPK and JNK pathways.

ACKNOWLEDGMENT

This study was funded by Universiti Sains Malaysia shortterm grant 304/CIPPT/6311033 and Advanced Medical and Dental Postgraduate Fund. The authors would like to extend their appreciation to the editor and statistician.

REFERENCES

- [1] Subhasis, D., Kumar, D. K., Goutam, D., Ipsita, P., Abhijit, M., Sujata, M., C. K. S. & Mahitosh, A. M.. Antineoplastic and Apoptotic Potential of Traditional Medicines Thymoquinone and Diosgenin in Squamous Cell Carcinoma. *PloS One*, 7(10), pp.e46641, 2012.
- [2] Roepke, M., Diestel, A., Bajbouj, K., Walluscheck, D., Schonfeld, P., Roessner, A., Schneider-Stock, R., & Gali-Muhtasib, H. Lack of p53 augments Thymoquinone-induced apoptosis and caspase activation in human osteosarcoma cells. *Cancer Biol Ther*, 6(2), pp.160-169, 2007.

- [3] El-Mahdy, M. A., Zhu, Q., Wang, Q. E., Wani, G. & Wani, A. A. Thymoquinone induces apoptosis through activation of caspase-8 and mitochondrial events in p53-null myeloblastic leukemia HL-60 cells. *Int J Cancer*, 117pp.409-417, 2005.
- [4] Arafat, El-S. A., Zhu, Q., Shah, Z. I., Wani, G., Barakat, B. M., Racoma, I., El-mahdy, M. A. & Wani, A. A. Thymoquinone up-regulates PTEN expression and induces apoptosis in doxorubicin-resistant human breast cancer cells. *Mutation Research/Fundamental and Molecular Mechanisms of Mutagenesis*, 706(1-2), pp.28-35, 2010.
- [5] Gali-Muhtasib, H., Diab-Assaf, M., Boltze, C., Al-Hmaira, J., Hartig, R., Roessner, A., & Schneider-Stock, R. Thymoquinone extracted from black seed triggers apoptotic cell death in human colorectal cancer cells via a p53-dependent mechanism. *Int J Oncol*, 25(4), pp.857-66, 2004.
- [6] Kaseb, A., Chinnakannu, K., Chen, D., Sivanandam, A., Tejwani, S., Menon, M., Dou, Q., & Reddy, G. Androgen receptor and E2F-1 targeted Thymoquinone therapy for hormone-refractory prostate cancer. *Cancer Res*, 67(16), pp.7782-8, 2007.
- [7] Woo, C. C., Loo, S. Y., Gee, V., Yap, C. W., Sethi, G., Kumar, A. P., Benny, T., & Huat, K. Anticancer activity of Thymoquinone in breast cancer cells: Possible involvement of PPAR-[gamma] pathway. *Biochemical Pharmacology*, 82(5), pp.464-75, 2011.
- [8] Broker, L. E., Kruyt, F. A. E. & Giaccone, G. Cell Death Independent of Caspases: A Review. *Clin Cancer Res*, 11(9), pp.3155-3162, 2005.
- [9] Chen, L., Aann Mayer, J., Krisko, T. I., Speers, C. W., Wang, T., Hilsenbeck, S. G. & Brown, P. H. Inhibition of the p38 Kinase Suppresses the Proliferation of Human ER-Negative Breast Cancer Cells. *Cancer Res* 69(23), pp.8853-8861, 2009.
- [10] Torres, M. P., Ponnusamy, M. P., Chakraborty, S., Smith, L. M., Das, S., Arafat, H. A., & Batra, S. K. Effects of Thymoquinone in the Expression of Mucin 4 in Pancreatic Cancer Cells: Implications for the Development of Novel Cancer Therapies. *Mol Cancer Ther*, 9(5), pp.1419-1431, 2010.
- [11] Mendoza, R. A., Moody, E. E., Enriquez, M. I., Mejia, S. M., & Thordarson, G. Tumorigenicity of MCF7 human breast cancer cells lacking the p38 α mitogen-activated protein kinase. *J Endocrinol*, 208(1), pp.11-19. *British Journal of Cancer*, 92(1), pp.113-119, 2011.
- [12] NCBI Resources. (2014). Gene. <http://www.ncbi.nlm>
- [13] Tvrdik, D., Skalova, H., Dunder, P., Povysil, C., Velenska, Z., Berkova, A., Stanek, L. & Petruzalka, L., Apoptosis - associated genes and their role in predicting responses to neoadjuvant breast cancer treatment. *Med Sci Monit*, 18(1), BR60-67, 2012.
- [14] Wang, X., Wang, H., Figueroa, B., Zhang, W., Huo, C., Guan, Y., Zhang, Y., Bruey, J., Reed, J., & Friendlander, R. Dysregulation of receptor interacting protein-2 and caspase recruitment domain only protein mediates aberrant caspase-1 activation in Huntington's disease. *J Neurosci*, 25(50), pp.11645-54.
- [15] Wang, X., Wang, H., Figueroa, B., Zhang, W., Huo, C., Guan, Y., Zhang, Y., Bruey, J., Reed, J., & Friendlander, R. Dysregulation of receptor interacting protein-2 and caspase recruitment domain only protein mediates aberrant caspase-1 activation in Huntington's disease. *J Neurosci*, 25(50), pp.11645-54.
- [16] Marjaneh, M., Al-hassan, FM., & Shahrul H. Thymoquinone regulates gene expression levels in the estrogen metabolic and interferon pathways in MCF7 breast cancer cells. *Int. J Mol. Med*, 33 (1):8-16, 2014.
- [17] Hosgood, H. R., Baris, D., Zhang, Y., Zhu, Y., Zheng, T., Yeager, M., Welch, R., Zahm, S., Chanock, S., Rothman, N., & Lan, Q. Caspase polymorphisms and genetic susceptibility to multiple myeloma. *Hematol Oncol*, 26(3), pp.148-151, 2009.
- [18] Smith, AL., Robin, TP., & Ford, HI. Molecular pathways: targeting the TGF- β pathway for cancer therapy. *Clin Cancer Res*, 18(17), pp.4514-21, 2012.
- [19] Dreesen, O. & Brivanlou, A. H. Signalling Pathways in Cancer and Embryonic Stem Cells. *Stem Cell Rev*, 3(1), pp.7-17, 2007.
- [20] Razandi, M., Oh, P., Pedram, A., Schnitzer, J., & Levin, E. R. ERs associate with and regulate the production of caveolin: implications for signalling and cellular actions. *Mol Endocrinol*, 16(1), pp.100-15, 2002.
- [21] Zhang, G., Ahmed, N., Riley, C., Oliva, K., Barker, G., Quinn, M., & Rice, G. Enhanced expression of peroxisome proliferator-activated receptor gamma in epithelial ovarian carcinoma. *British Journal of Cancer*, 92(1), pp.113-119, 2005.
- [22] Xu, Y., Yang, G., & Hu, G. Binding of IFITM1 enhances the inhibiting effect of caveolin-1 on ERK activation. *Acta Biochim Biophys Sin (Shanghai)*, 41(6), pp.488-94, 2009.
- [23] Valeria, B., Larbi, A., Cruz, Hinojos, Jeannie, Z., Maureen, G., Mancini, M., Zelton, D. S., & Mancini, M. A. Activation of Estrogen Receptor- α

- by E2 or EGF Induces Temporally Distinct Patterns of Large-Scale Chromatin Modification and mRNA Transcription. *PlosOne*, 3, e2286, 2008.
- [24] Finlay, T. M., Abdulkhalek, S., Gilmour, A., Guzzo, C., Jayanth, P., Amith, S. R., Gee, K., Beyaert, R. & Szewczuk, M. R. Thymoquinone-induced Neu4 sialidase activates NFκB in macrophage cells and pro-inflammatory cytokines in vivo. *Glycoconj J*, 27(6), pp.583-600, 2010.
- [25] Filardo, E. J., Quinn, J. A., Frackelton, AR. JR & Bland, KI. Estrogen action via the G protein-coupled receptor, GPR30: stimulation of adenylyl cyclase and cAMP-mediated attenuation of the epidermal growth factor receptor-to-MAPK signalling axis. *MolEndocrinol*, 16(1), pp.70-84, 2012.
- [26] Albanito, L., Madeo, A., Lappano, R., Vivacqua, A., Rago, V., Carpino, A., Oprea, T., Prossnitz, ER., Musti, AM., Andò, S., Maggiolini, M. G protein-coupled receptor 30 (GPR30) mediates gene expression changes and growth response to 17beta-estradiol and selective GPR30 ligand G-1 in ovarian cancer cells. *Cancer Res.* 67(4):1859-66, 2007.
- [27] Koka, P. S., Mondal, D., Schultz, M., Abdel-Mageed., & Agrawal, K. C. Studies on molecular mechanisms of growth inhibitory effects of Thymoquinone against prostate cancer cells: role of reactive oxygen species. *Experimental Biology and Medicine*, 235(6), pp.751-760, 2010.