

# Improvement on a CNC Gantry Machine Structure Design for Higher Machining Speed Capability

Ahmed A. D. Sarhan, S. R. Besharaty, Javad Akbaria, M. Hamdi

**Abstract**—The capability of CNC gantry milling machines in manufacturing long components has caused the expanded use of such machines. On the other hand, the machines' gantry rigidity can reduce under severe loads or vibration during operation. Indeed, the quality of machining is dependent on the machine's dynamic behavior throughout the operating process. For this reason, these types of machines have always been used widely and are not efficient. Therefore, they can usually be employed for rough machining and may not produce adequate surface finishing. In this paper, a CNC gantry milling machine with the potential to produce good surface finish has been designed and analyzed. The lowest natural frequency of this machine is 202 Hz corresponding to 12000 rpm at all motion amplitudes with a full range of suitable frequency responses. Meanwhile, the maximum deformation under dead loads for the gantry machine is 0.565 $\mu$ m, indicating that this machine tool is capable of producing higher product quality.

**Keywords**—Finite element, frequency response, gantry design, gantry machine, static and dynamic analysis.

## I. INTRODUCTION

CNC gantry machine tools have been extensively utilized in producing large components. One of the most important applications of the five-axis CNC gantry machine is in the mold industry. This type of machine tool is widely used for the machining of complex components [1]. High-accuracy CNC machine tools are required in many manufacturing industries due to the demand for precision and consistency of quality [2]. The geometry of CNC gantry machines is principally designed for machining long components. However, the machine gantry's rigidity gets reduced under severe loads during machining operations. Consequently, excessive vibration and deformation may occur.

Manufacturers have attempted to design a stiff-structure machine tool to lessen vibration, so it would be stable throughout machining [3]. The design process and fabrication limitations have created difficulties in achieving good advantages. Normally the first natural frequencies of existing machine structure designs are seldom higher than 100Hz, corresponding to spindle speeds of around 6000rpm [4], [5].

Ahmed. A.D. Sarhan is with the Center of Advanced Manufacturing and Material Processing, Department of Mechanical Engineering, Faculty of Engineering, University of Malaya, Kuala Lumpur, 50603, Malaysia (Corresponding author phone: +60379674593; fax:+60379675330; e-mail: ah\_sarhan@um.edu.my).

S. R. Besharaty and M. Hamdi are with the Center of Advanced Manufacturing and Material Processing, Department of Mechanical Engineering, Faculty of Engineering, University of Malaya, Kuala Lumpur, 50603, Malaysia (e-mail: r.besharati@yahoo.com, hamdi@um.edu.my).

Javad Akbaria is with the Department of Mechanical Engineering, Sharif University of Technology, Iran (e-mail: akbari@sharif.edu).

Though for good surface finishing, machine tools should reach over 8000rpm. As such, the lowest natural frequency of a machine gantry must be higher than 140Hz. On the other hand, for the finishing process, high spindle speed is required.

Milling machines with less than 150Hz natural frequency are not able to produce high-quality products. Thus, a CNC gantry machine design for high-speed machining operations requires an appropriate gantry structure. This study is done to show modifications made to the machine structure so it can reach up to 200Hz natural frequency corresponding to 12000rpm spindle speed. For this, the gantry structure must be able to resist vibration at high-speed machining operations. To perform satisfactorily, a machine tool must be rigid statically and dynamically simultaneously. Therefore, component dimensional accuracy is achievable with static stiffness during the machining process. Surface quality and maximum metal removal rates will be obtained with dynamic stiffness [6]. Yet, cutting process stability is related to the dynamic performance of a machine tool's gantry structure [7]. In order to evaluate the resistance of machine tools against vibration, it is necessary to assess both the design and the machine tool's gantry structure concurrently. If the initial demands are not met, the design would require modification, as it must perform relative to the analytical result. This process can be repeated until the requirements are achieved and satisfied. Nevertheless, the cutting process will be stable, with good machining performance, when the resulting design and dynamic analysis of the machine tool gantry structure have considerable stiffness and sufficient damping [8].

## II. METHODOLOGY

The first small-scale gantry structure was designed for the present study. An existing design was evaluated, requirements were defined, ideas generated and a preliminary design was drafted. Controlling and coordinating the design with standard components, static and dynamic analysis, and modifications to the gantry design were carried out. A study of the dynamic behavior of the gantry structure during deformation was conducted. Adjustment based on the results is determined as an evaluation cycle, as shown in Fig. 1. After the machine gantry was designed, the dynamic structure behavior was evaluated using finite-element software.

## III. INITIAL 3D MODEL OF GANTRY MACHINE STRUCTURE

At first a gantry machine of 600x500x300 mm was designed. Machining operation speed of 12,000 rpm and accuracy of 10 microns were predicted as the machine's capability. The preliminary design of the gantry machine is

illustrated in Fig. 2. For static and dynamic analysis processes, a 3D model of the gantry structure was converted to ANSYS format as shown in Fig. 3. Cast iron with  $1.1 \times 10^{11}$  Pa Young's modulus,  $7200 \text{ Kg-m}^{-3}$  density and 0.28 Poisson's ratio was selected to manufacture the gantry machine [9]. During the course of analysis, the mass of the gantry was 417.75Kg, each column was 93.55Kg and the beam was 118.8 Kg. The procedure of design evaluation includes an investigation of structural deformation under static forces (weight, shear forces) and the structure's dynamic behavior.

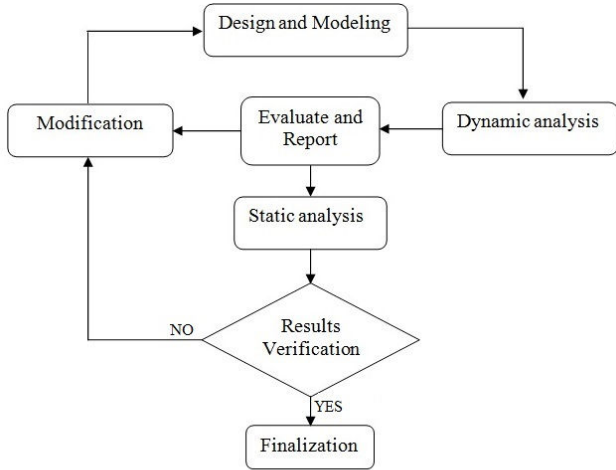

Fig. 1 The modification cycle

to change. Therefore, the natural frequencies of the structure modify when the position of the movable parts changes. Hence modal analysis of the gantry for various spindle positions was done to identify the lowest frequency as shown in Fig. 4.

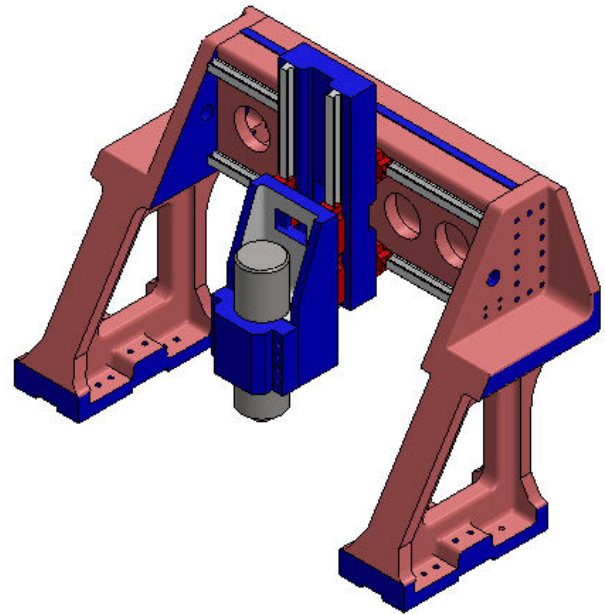

Fig. 3 3D model of the structure

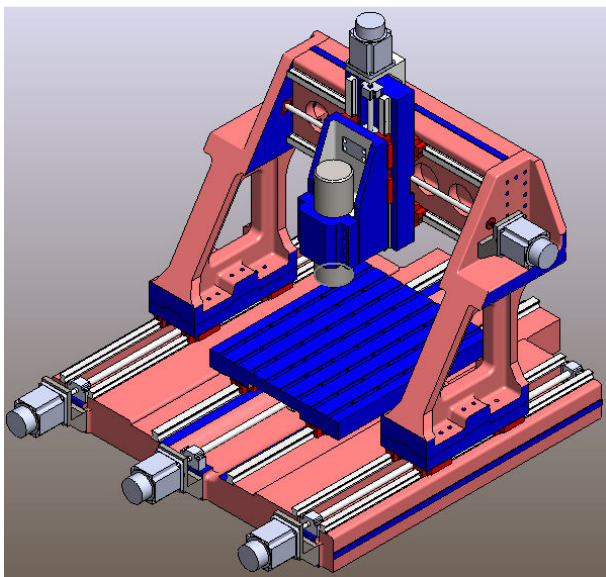
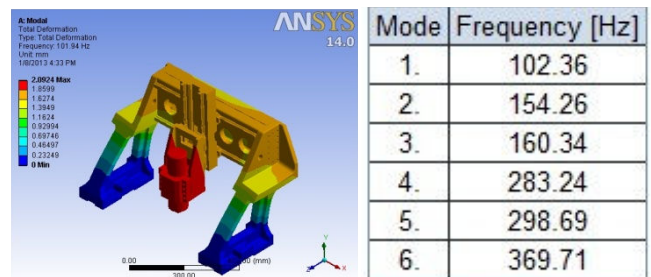

Fig. 2 The preliminary design of the gantry machine

#### IV. DYNAMIC BEHAVIOR OF STRUCTURES

The structure's dynamic behavior response was evaluated using the modal analysis technique. The lowest natural frequency and modes were extracted. In designing the gantry machine, the primary challenge regarded the movable part is the dynamic behavior of the structure changes at different positions on the Z-axis component related to the gantry beam. The movable parts cause the distribution of mass and stiffness



(a) The spindle at the middle positions of Y axis

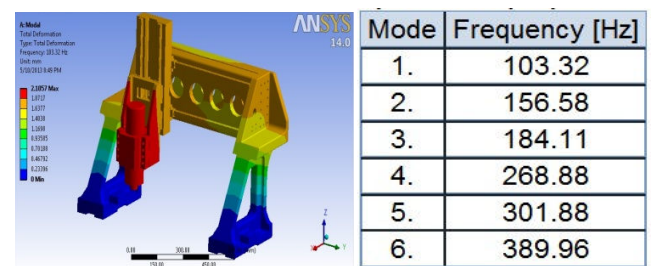

(b) The spindle at the side position of Y axis

Fig. 4 The dynamic analysis of the initial gantry structure design

As can be seen in Figs. 4 (a) and (b), and due to insufficient rigidity, columns structurally vibrated at different frequencies and mode directions. The lowest natural frequency of the gantry structure is found to be 102Hz while the target is to reach up to 200Hz. The influence of moving part displacement

on identifying the lowest frequency of the gantry structure was evaluated. The minimum frequency occurred when the spindle was in the middle position of the Y-axis. It means that this spindle location is a critical point, for which reason subsequent analysis was done in this position.

## V. DESIGN MODIFICATION PROCESS

### A. Gantry Geometry Modification

In order to increase the structure's rigidity, the column cross section geometry of the gantry structure was modified in this step. The design modification process to increase the gantry's stiffness was repeated several times successively for various columns and beams; the geometric shapes are shown in Figs. 5 and 6. Next, dynamic analysis was performed for the final modified gantry structure as shown in Fig. 7. The result indicates that the lowest natural frequency increased up to 176.25Hz, but the target to achieve (200Hz) is still not achieved, hence the design is requiring further modification.

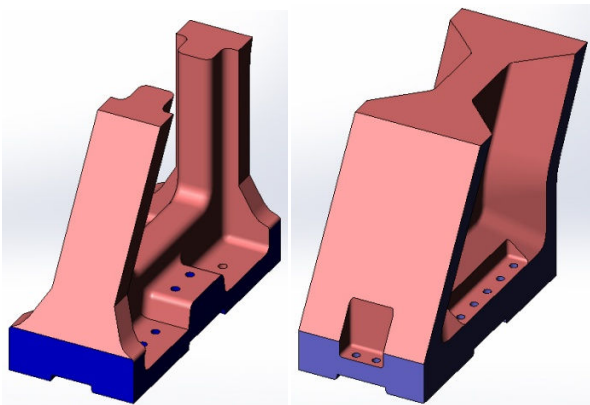

(a) Initial designs (b) Final designs

Fig. 5 Columns geometry and dimension modification

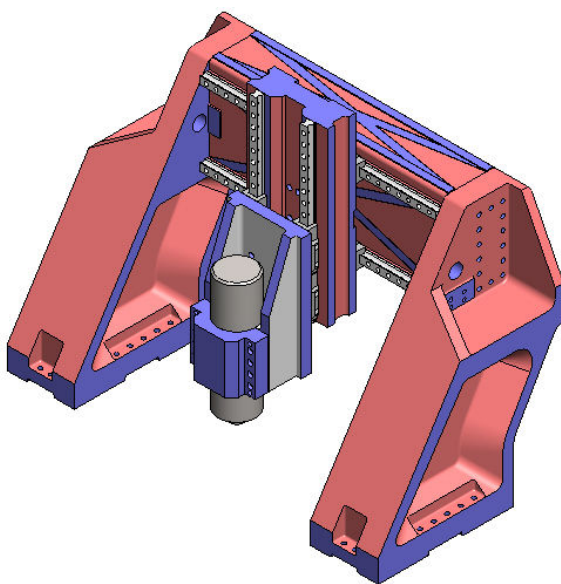

Fig. 6 The final modified gantry structure

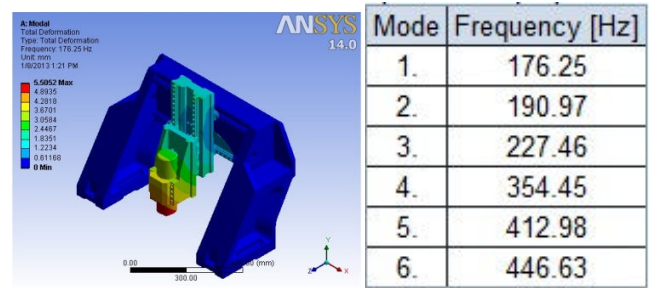

Fig. 7 The result of dynamic analysis of the modified gantry structure

### B. Gantry Material Modification

According to the outcome shown in Fig. 7 whereby the gantry was manufactured using cast iron, the natural frequency was found to be 176.25Hz, which is still below the required frequency of 200Hz. To perform additional modification to reach the required frequency, the gantry material had to be changed. Cast iron is the material most commonly used for machine tool structures for the past several years. Lately, due to advances in welding technology, welded steel structures are finding more extensive applications. A number of factors are discussed to deliberate on whether the structure should be made of cast iron or steel.

Cast iron has higher inherent damping, better sliding and low cost manufacturing. Steel has superior strength under static and dynamic loading, as well as unit rigidity under tensile, torsional and bending loads. In addition, welded steel structure joints are able to possess high damping too. However, the high cost and long manufacturing processes are among the disadvantages of steel structures. Based on the considerations discussed, the function of cast iron and steel may be specified as follows. Steel structures should be made for simple, heavy loads that are manufactured in small numbers. Cast iron structures should be made for complex structures subjected to normal loading and that are to be made produced in large numbers. Lately, combined welded and cast structures are becoming popular. They are generally used where a steel structure is economically suitable but difficult to manufacture owing to the complexity of some parts; these complex parts would then be separately cast and welded to the main structure [8], [10]. Therefore, the combination of steel and cast iron is the best solution in this case. The beam material selected is made from welded steel as it is not complicated to manufacture, while the two columns were cast using cast iron. Dynamic analysis of the new machine structure using the combination of steel and cast iron was performed as shown in Fig. 8. As seen in Figs. 8 (a) and (b) the lowest frequency achieved is 202.23Hz, which corresponds with the requisite design factor.

## VI. HARMONIC ANALYSIS

In the following step, the total amount of deformation the structure underwent during vibration was investigated with harmonic analysis and frequency response for the first two modes. Furthermore, non-linear parameters, such as damping were applied to the spindle's tips and the responses were

assessed for different coordinates (Fig. 9). The maximum spindle tip deformation during vibration was 0.013μm. The results of the dynamic analysis and evaluations of the structure are acceptable.

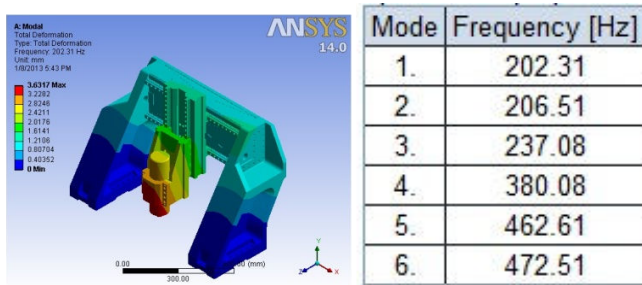

(a) The middle position of spindle

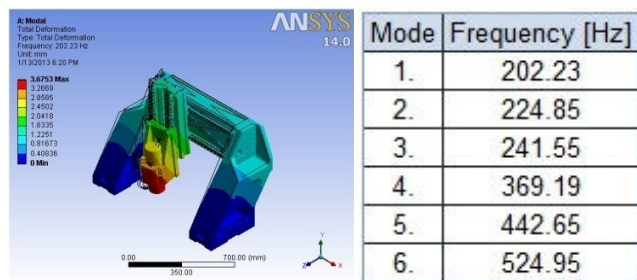

(b) The side position of spindle

Fig. 8 The dynamic analysis of the gantry structure using combination of steel and cast iron

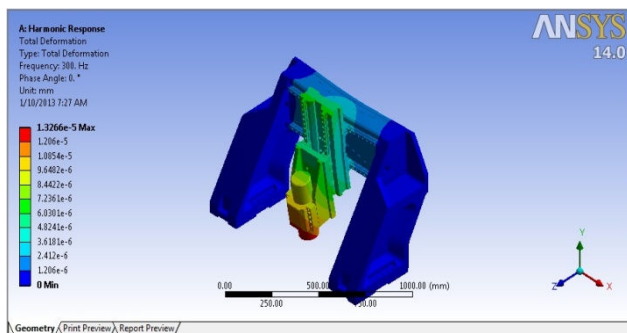

Fig. 9 Total deformation in harmonic response

### VII. STATIC FORCES ANALYSIS

After modifications, the total weight of the gantry structure was 627.0Kg, with each column weighing 191.83Kg, the beam 114.3Kg, and the Z-axis part 129.06 Kg. Hence, the entire beam deformation under the weight of the beam and the Z-axis part (243.36 Kg) was evaluated and the result is presented in Fig. 10. It is obvious from this figure that the total deformation under the weight is low and does not affect the machine's accuracy.

To investigate the deformation caused by cutting forces, the standard spindle selected had 3.3Nm torque, 6kW power and 12,000rpm spindle speed. The amount of force generated at the edge of the 8mm diameter end-mill was  $F = 825\text{Nm}$ . For

gantry structure behavior evaluation under the total amount of force ( $F=990\text{N}$ ) with the safety coefficient  $C=1.2$ , force was applied at the edge of the end-mill. The maximum deformation was extracted by static analysis. Analysis results are given in Fig. 11.

Fig. 11 points out that the maximum deformation on the spindle tip under maximum force with the condition of critical position of the beam's Z-axis part obtained was 0.0099mm. Thus target accuracy (10 microns) was achievable even in a critical condition. In addition, the total errors, including the machine's fabrication tolerance and assembly process could be calculated as well [11]-[13]. These determined the machine's precision. In any case, cutting forces with their shake phenomenon lead to some undesirable deformations, besides altered accuracy and stability during machining [14], [15].

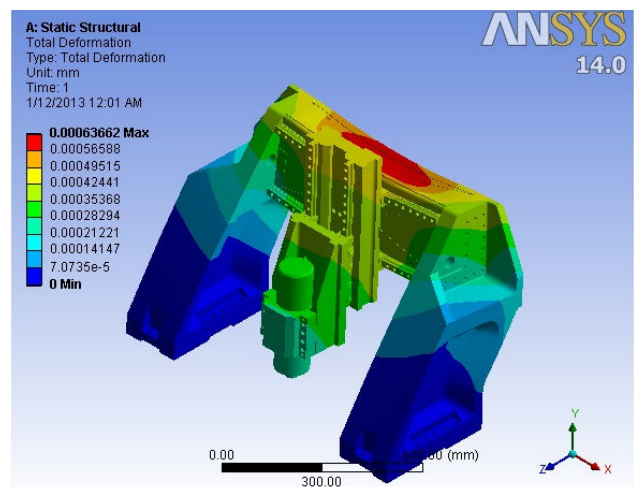

Fig. 10 The total deformation of the beam under the weight

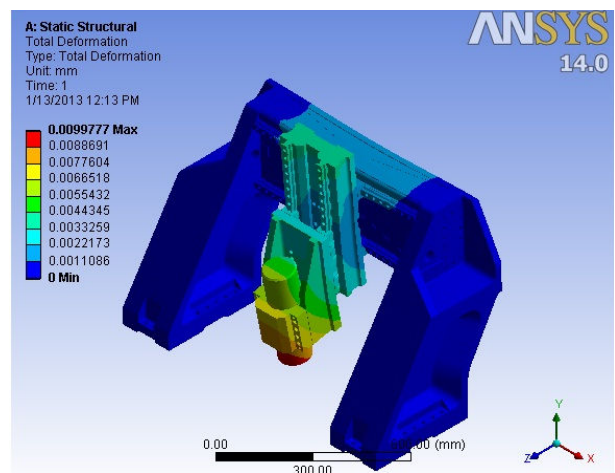

Fig. 11 The static analysis result

### VIII. CONCLUSION

In this paper, an initial CNC gantry milling machine structure with the potential to produce high surface finish has been designed and analyzed. The target was to achieve lowest natural frequency of 200Hz corresponding to 12000 rpm at all

motion amplitudes with a full range of suitable frequency responses. Modal analysis of the initial gantry structure design was performed and its natural frequency was 102.36HZ. To improve the dynamic behavior of the gantry structure so it can endure at frequencies above 200HZ, a modification process was carried out to increase stiffness. Following enhancement, appropriate behavior was attained. Deformation of less than 10 microns ensued at the tip of the spindle when the minimum natural frequency of the gantry structure rose slightly above 200Hz. An increase in the structure's weight was the significant factor for the identified deformation. However, the variation did not have a negative impact on the precision of the machine. As a result, the weight increased after modifications to the gantry structure were made, while the amount of deformation and overall dynamic behavior improved. In addition, the efficacy of the Z-axis part's position on the dynamic behavior of the gantry structure was studied. By displacement of the spindle position, the dynamic behavior of gantry structures will change. Evaluations on the gantry structure's behavior demonstrated that the least natural frequency occurred while the Z-axis part was located below the middle of the beam. This signifies that the structure was in a critical situation. The results show that according to the critical condition, the minimum frequency of the structure is acceptable.

The research results show that the designed CNC gantry machine is capable of functioning at a speed of 12,000rpm. Nevertheless, additional research is required for more optimal gantry machine design.

#### ACKNOWLEDGMENT

This work was supported by the high impact research (HIR) grant number: HIR-MOHE-16001-00-D000027 from the Ministry of Higher Education, Malaysia.

#### REFERENCES

- [1] Sencer, B., Y. Altintas, and E. Croft, Feed optimization for five-axis CNC machine tools with drive constraints. *International Journal of Machine Tools and Manufacture*, 2008. 48(7-8): p. 733-745.
- [2] Raksiri, C. and M. Parnichkun, Geometric and force errors compensation in a 3-axis CNC milling machine. *International Journal of Machine Tools & Manufacture*, 2004. 44(12): p. 1283-1291.
- [3] Suh, J. and D. Lee, Design and manufacture of hybrid polymer concrete bed for high-speed CNC milling machine. *International Journal of Mechanics and Materials in Design*, 2008. 4(2): p. 113-121.
- [4] Fansen, K. and Y. Junyi, Fuzzy dynamic response analysis of machine tool structure. *International Journal of Machine Tools and Manufacture*, 1999. 39(12): p. 1993-2002.
- [5] Albertelli, P., et al., The effects of dynamic interaction between machine tool subsystems on cutting process stability. *The International Journal of Advanced Manufacturing Technology*, 2012. 58(9-12): p. 923-932.
- [6] Du, H., C. Zhao, and W. Wu, Stability criteria based on argument principle of a general dynamical system in cutting process. *The International Journal of Advanced Manufacturing Technology*, 2013, DOI: 10.1007/s00170-013-5313-2.
- [7] Biermann, D. and A. Baschin, Influence of cutting edge geometry and cutting edge radius on the stability of micromilling processes. *Production Engineering*, 2009. 3(4-5): p. 375-380.
- [8] Murakami, T., et al., Damping and tribological properties of Fe-Si-C cast iron prepared using various heat treatments. *Materials Science and Engineering: A*, 2006. 432(1-2): p. 113-119.

- [9] Zhang, Y., et al., The Theory of Response Analysis of Fuzzy Stochastic Dynamical Systems With a Single Degree of Freedom. *Earthquake Engineering & Structural Dynamics*, 1996. 25(3): p. 235-251.
- [10] Mehta, N.K., *Machine tool design and numerical control* 1996, New Delhi: Tata McGraw-Hill Pub.
- [11] Yin, J., M. Li, and C. Xu, Geometric Errors Measurement of a Large Scale Five-Axis Gantry Type High Speed Machine Tool, *Advances in Automation and Robotics*, Vol.1, Lecture Notes in Electrical Engineering Volume 122, 2012, pp 93-99.
- [12] Lamikiz, A., et al., The Denavit and Hartenberg approach applied to evaluate the consequences in the tool tip position of geometrical errors in five-axis milling centres. *The International Journal of Advanced Manufacturing Technology*, 2008. 37(1-2): p. 122-139.
- [13] Lamikiz, A., L.N. López de Lacalle, and A. Celaya, *Machine Tool Performance and Precision, in Machine Tools for High Performance Machining*, 2009, Springer London. p. 219-260.
- [14] Olvera, D., et al., Analysis of the tool tip radial stiffness of turn-milling centers. *The International Journal of Advanced Manufacturing Technology*, 2012. 60(9-12): p. 883-891.
- [15] Hung, J.-P., and e. al., Modeling the machining stability of a vertical milling machine under the influence of the preloaded linear guide. *International Journal of Machine Tools and Manufacture*, 2011. 51(9): p. 731-739.

**Ahmed. A. D. Sarhan** is graduated with a PhD from the Precision Engineering Department, Kyoto University, Japan. During his work in Japan for around 6 years, he gained experience in the field of intelligent manufacturing processes. He worked with the Intelligent Numerical Control (INC) Research Consortium with multiple industrial and academic partners. He developed an intelligent spindle for CNC machine tools with displacement and thermal sensors to simultaneously monitor the spindle characteristics and machining process in order to protect the spindle from damage at higher spindle speeds.

In 2009, Dr. Sarhan joined University of Malaya, Kuala Lumpur, Malaysia. Throughout his engineering career, he have completed several major research projects funded by the public and private sectors and has also undertaken various consulting assignments in the field of machining (higher accuracy and higher productivity machining technologies) and cutting tool technology (metal cutting operations using multiple sensors, data acquisition, and signal processing technology). He published more than (120) technical papers in reputable journals and conferences, granted 19 patents and won several gold, silver and bronze medals in local and international exhibitions. In addition, he is a reviewer for many Master and PhD theses, some reputable engineering journals and refereed international conferences.