

Parametric Investigation of Aircraft Door's Emergency Power Assist System (EPAS)

Marshal D. Kafle, Jun H. Kim, Hyun W. Been, Kyoung M. Min, Sung H. Kim

Abstract—Fluid viscous damping systems are well suited for many air vehicles subjected to shock and vibration. These damping system work with the principle of viscous fluid throttling through the orifice to create huge pressure difference between compression and rebound chamber and obtain the required damping force. One application of such systems is its use in aircraft door system to counteract the door's velocity and safely stop it. In exigency situations like crash or emergency landing where the door doesn't open easily, possibly due to unusually tilting of fuselage or some obstacles or intrusion of debris obstruction to move the parts of the door, such system can be combined with other systems to provide needed force to forcefully open the door and also securely stop it simultaneously within the required time i.e. less than 8 seconds. In the present study, a hydraulic system called snubber along with other systems like actuator, gas bottle assembly which together known as emergency power assist system (EPAS) is designed, built and experimentally studied to check the magnitude of angular velocity, damping force and time required to effectively open the door. Whenever needed, the gas pressure from the bottle is released to actuate the actuator and at the same time pull the snubber's piston to operate the emergency opening of the door. Such EPAS installed in the suspension arm of the aircraft door is studied explicitly changing parameters like orifice size, oil level, oil viscosity and bypass valve gap and its spring of the snubber at varying temperature to generate the optimum design case. Comparative analysis of the EPAS at several cases is done and conclusions are made. It is found that during emergency condition, the system opening time and angular velocity, when snubber with 0.3mm piston and shaft orifice and bypass valve gap of 0.5 mm with its original spring is used, shows significant improvement over the old ones.

Keywords—Aircraft Door Damper, Bypass Valve, Emergency Power Assist System, Hydraulic Damper, Oil viscosity.

I. INTRODUCTION

HYDRAULIC shock absorbers are used in several applications like hydraulic excavators, aircraft doors and landing gear, car shock absorbers, in bridges for stabilization, helicopters, in earthquake resistant buildings etc. [1]. In the

M. D. Kafle is with the Sacheon Aerospace Manufacturing Industries Co., Ltd., Sacheon, Kyounghnam, Korea 664-942 (phone: 8255-850-7777; e-mail: mdk@samcokorea.com).

J.H. Kim is with the Sacheon Aerospace Manufacturing Industries Co., Ltd., Sacheon, Kyounghnam, Korea 664-942 (phone: 8255-850-7734; e-mail: jhkim1@samcokorea.com).

H.W. Been is with the Sacheon Aerospace Manufacturing Industries Co., Ltd., Sacheon, Kyounghnam, Korea 664-942 (phone: 8255-850-7776; e-mail: hwbeen@samcokorea.com).

K.M. Min is with the Sacheon Aerospace Manufacturing Industries Co., Ltd., Sacheon, Kyounghnam, Korea 664-942 (phone: 8255-850-7787; e-mail: kmmin@samcokorea.com).

S.H. Kim is with the Sacheon Aerospace Manufacturing Industries Co., Ltd., Sacheon, Kyounghnam, Korea 664-942 (phone: 8255-850-7781; e-mail: shkim@samcokorea.com).

case of aircraft door, generally, snubber also known as damper is used to decrease the velocity of the door while opening it and prevent it from slamming into the fuselage. Normally, commercial aircraft have number of doors that require operation in several scenarios such as non-emergency situations like normal entry exit door opening, maintenance and routine checking, and emergency situations like crash landing or emergency landing where the door doesn't open easily possibly due to unusually tilting of fuselage or some obstacles or intrusion of debris obstruction to move the parts of the door. It is therefore demanded that there be a system that can assist in forcefully opening the door fast enough to let the safe escape for the passengers during emergency situations but also not be so fast that it swivels and slams with the other nearby objects. For this purpose, the door generally is designed in such a manner that the total opening time including the inflation of the evacuation slide is performed in no more than 10 seconds [2].

The door of an airplane is movable which is connected with a suspension arm by the way of two fittings. The other end of the suspension arm is disposed at fuselage side frame. During the opening operation, the passenger door, is lifted after unlocking and from the end of the lifted position, is swiveled into an opening position until it is stopped. During emergency condition, the process of swiveling the door is done using gas from the bottle which is fed to the actuator. This action opens the door and as it is about to make one full stroke, it is safely stopped by the snubber's damping force. The snubber, in particular is responsible for creating damping force. In most cases, fluid dampers are used which operate on the principle of fluid flow through orifices [3]. Fluid dampers used in vehicles and aircrafts use piston with number of orifices and disc shaped shim. For example, when the vehicle undergoes vertical excitation, the oil is forced to leave from orifice of piston from compression chamber to rebound chamber. As the oil throttles through the orifice, the pressure difference of these chambers generate the damping force [4], [5]. In the aircraft, the damper along with other parts like actuator, bottle are installed in door suspension arm and during emergency condition, the flight stewardess control these parts to forcefully open the door. These parts together is termed as Emergency Power Assist System (EPAS).

In this paper, several parametric studies performed in the snubber are shown. Actuator is intended just to use gas pressure from the bottle and help in opening the door. As mentioned previously, it is snubber which creates damping, the requirements like opening time and moving velocity are controlled by changing its parameters [6]. Therefore, the

intention of this research is only to perform parametric study of snubber and check the overall behavior of the system. Also, without the inflation time of evacuation slide, the opening time of current system or in other words the time required to complete full stroke by the piston of snubber is set to be no more than 8 seconds.

II. INSTALLATION AND WORKING OF EPAS

EPAS consists of bottle assembly, actuator assembly and snubber assembly as shown in Fig. 1. The bottle assembly is connected to actuator using vent valve and the actuator piston shaft is connected to piston shaft of snubber. The bottle assembly with nitrogen gas pressurized at approximately 1000 psi is used to activate the actuator. The 1000 psi gas pressure is exactly fed into actuator using the regulator of the bottle assembly. Time delay valve, a part of bottle assembly through which the gas flows provide a small time lag as the handle is pushed to upright position to open the door. This prevents sudden movement of the door and abstain personnel using it from injuries.

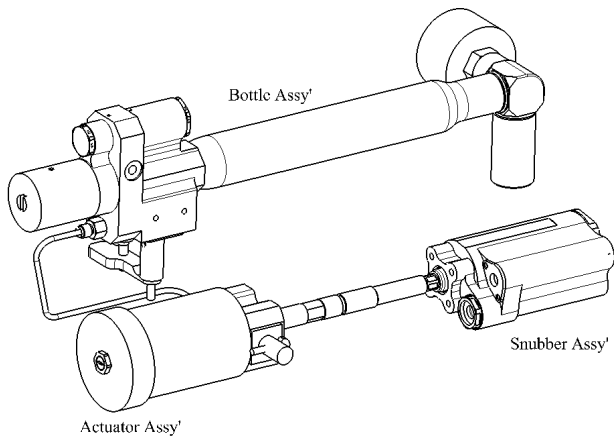

Fig. 1 Emergency power assist system

As the gas comes from bottle assembly, it enters the actuator from the inlet port. The gas then moves through vent to impose pressure in the actuator shaft's piston. If the gas pressure is enough, the piston is pushed down along with the shaft. This represents the opening of the door during emergency condition. One of the factor that affects the opening time is the amount of pressure provided to actuator. The pushing down of actuator shaft pulls the snubber shaft along with its piston. The snubber piston contains seal which prevents the flow of oil through walls from compression to rebound chamber and only let the oil throttle from piston orifice and shaft orifice and through bypass valve.

Bypass valve is a manually controlled hydraulic valve and can be seen in Fig. 2. The spring and the gap of the valve determines the magnitude of additional damping force. If the bypass valve is fully open, low bypass induced damping effect is realized but when the bypass valve is tightened, higher damping force can be achieved. The bypass valve is particularly important as the adjusting lock nut can be recalibrated incase the desired damping is not obtained. This

restricts the flow of oil over specific flux to provide higher damping force. As the oil passes through vent, bypass valve gap and its spring can be controlled to meet the damping requirements. Also, a reservoir is made in the snubber which holds the excess oil remained during snubber rebound stroke due to volume difference of two chambers [7].

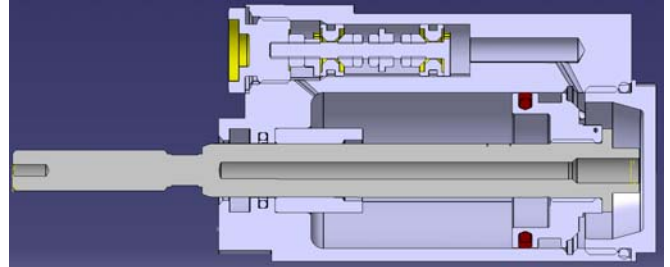

Fig. 2 Snubber internal parts

A. Snubber Design Requirement

As designed, piston with a double orifice and area of 2.945 inch² is connected in line with snubber. According to design requirement, when the actuator is pressurized, the whole system should not provide door angular velocity larger than 1.20 rad/sec and when it is about to stop, it should be no more than 0.23 rad/sec. Addition to this, the system shall complete its full stroke in less than 8 sec complying with several environmental conditions like temperature variation, vibration, humidity, icing etc. Among all of these, the temperature variation requirement is quite important as the system has to be operable in wide temperature range of -55°C to 50°C. Thus several tests are performed changing snubber parameters to check if opening time and angular velocity requirements are met at room and low temperature of -30°C, -40°C and -55°C.

As damping force, time and pressure difference are directly proportional, these terms can be correlated and expressed in terms of flow rate, viscosity, piston velocity, orifice diameter and piston and orifice cross sectional area.

The flow rate inside the snubber is dependent on flow discharge coefficient, orifice flow area and pressure difference which is expressed in (1):

$$Q = C_d A_0 \sqrt{\frac{2\Delta P}{\rho}} = A_p v_p \quad (1)$$

where, Q is the flow rate, C_d is the flow discharge coefficient, A_0 denotes the flow area of the orifice, ρ is the density of the oil, A_p is the effective cross section area of piston and v is the piston velocity.

The flow discharge coefficient C_d is dependent on viscosity and orifice diameter and it is given by (2):

$$C_d = k \sqrt{N_{RE}} = k \sqrt{\frac{\rho \left(\frac{Q}{A_0}\right) d}{\mu}} \quad (2)$$

The total damping force in snubber is the sum of damping force due to fluid and friction and this is expressed in (3):

$$F_d = F_f + F_p = F_f + (\Delta P)A_p \quad (3)$$

Combining (1)-(3), the damping force (F_d) is calculated as (4):

$$F_d = F_f + \left[\frac{\mu A_p^2 v_p}{2k^2 A_0 d} \right] \quad (4)$$

where, F_f is damping due to friction, μ is the fluid viscosity, A_p is the effective cross section area of piston, v_p is piston velocity, k is the discharge coefficient, A_0 is the cross section area of damper orifice and d is the orifice diameter.

From (4), it can be noticed that the damping force is directly proportional to viscosity, cross sectional area of piston, piston velocity and inversely proportional to cross sectional area of damper orifice, orifice diameter and discharge coefficient. Thus, further tests are performed based on this fact. The discharge coefficient k changes with the orifice inlet/outlet angle. The relationship between discharge coefficient to Reynold's no. and orifice inlet/outlet angle is shown in Fig. 3 [8].

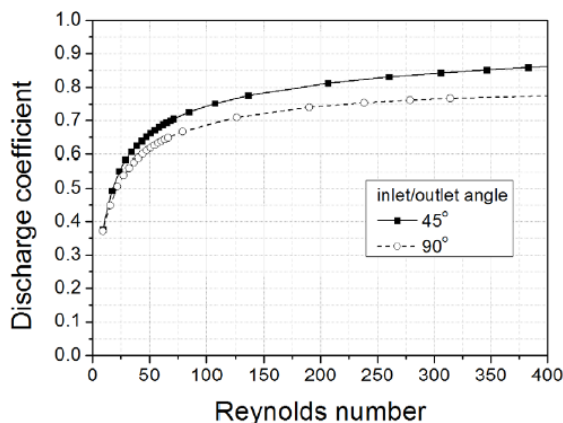

Fig. 3 Relationship between discharge coefficients to Reynolds number

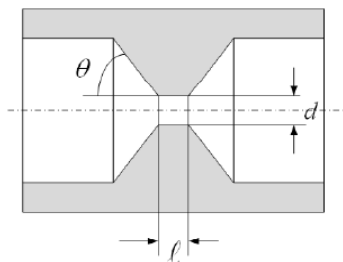

Fig. 4 Visualization of orifice diameter and inlet/outlet angle

$$R_e = \frac{Qd}{vA_0} \quad (5)$$

The Reynold's no. as an oil is throttled through the orifice of diameter d , length l and orifice cross section area A_0 can be

calculated using (5). The kinematic viscosity, $\nu = \frac{\mu}{\rho}$ where μ is the dynamic viscosity and ρ is the density of the fluid. The configuration of orifice in the present snubber is shown in Fig. 4. Several orifices with different diameter are made to analyze the effect of it in damping.

As mentioned earlier, the EPAS has to be operable in wide range of temperature, i.e. from -60°C to 50°C . As fluid viscosity varies with both the temperature and chemical composition of the fluid, it is required that the correct fluid is chosen. The most famous equation to get viscosity temperature relationship of oil is the Walther equation which is shown in (6). Fig. 5 shows the viscosity decrease of the fluid with the decrease of temperature.

$$\log \log (\eta + c) = a - b \log T \quad (6)$$

where a and b are constants of particular fluid and c varies with viscosity.

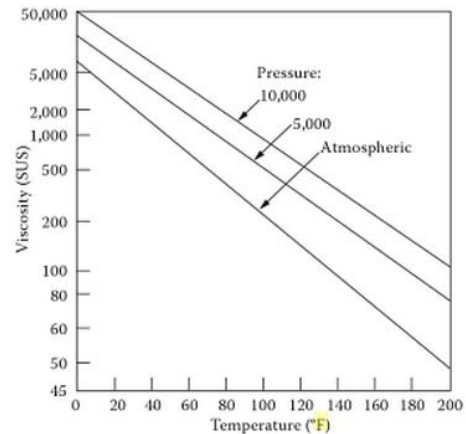

Fig. 5 Viscosity temperature relationship [6]

Two silicon oil with viscosity level CST 50 and CST 100 for the snubber are tested. At low temperature, CST 100 is more viscous than CST 50 silicon oil.

III. TESTING SCENARIO OF SNUBBER

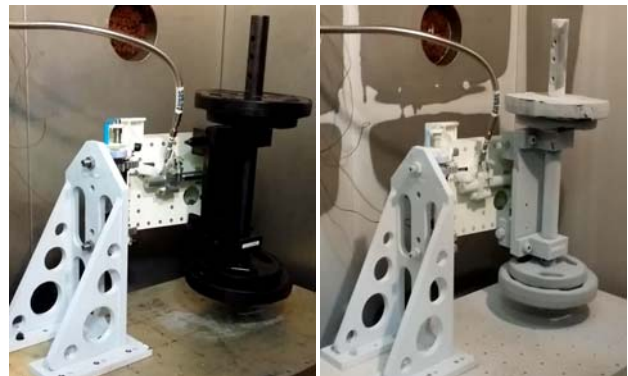

Fig. 6 Door dummy mass and arm during test inside temperature chamber

Fig. 6 shows the EPAS installed in suspension arm along with the dummy mass (for door) inside the temperature chamber. Two thermocouples are installed while testing to check if the temperature is stabilized. Rotary encoder is used at the pivot to measure the angular velocity with respect to the angle. Pressure as required is charged to the bottle and then fed to actuator and test is conducted.

Several cases are presented in Table I according to which the tests are performed.

TABLE I
 TEST CASES

Case	Conditions	Remarks
1	Piston Orifice 0.2 mm	In case 1, the weight of snubber is 495 g. This means that the snubber is not fully filled with hydraulic oil.
	Shaft Orifice 0.3 mm	
	Bypass Valve Gap 1 mm	
	Bypass Spring k	
2	Piston Orifice 0.3 mm	For case 2, 3 and 4, the weight of snubber is around 560 g. (Level of oil is increased)
	Shaft Orifice X	
	Bypass Valve Gap 1 mm	
	Bypass Spring k	
3	Piston Orifice 0.3	
	Shaft Orifice 0.3	
	Bypass Valve Gap 0.5	
	Bypass Spring k/4	
4	Piston Orifice 0.3	
	Shaft Orifice 0.3	
	Bypass Valve Gap 0.5	
	Bypass Spring k	
5	Piston Orifice 0.3 mm	Without Regulator
	Shaft Orifice X	
	Bypass Valve Gap 1 mm	
	Bypass Spring k	

In case 1, snubber piston orifice is fixed at 0.2 mm. The orifice of its shaft is set to 0.3mm. The bypass valve gap is set at 1mm with spring constant as designed value. Case 2 is same except that the piston orifice is increased to 0.3mm and shaft orifice is closed. In case 3, the piston orifice and shaft orifice both are set at 0.3mm. The bypass valve is decreased from 1 to 0.5mm and designed spring constant is decreased by four times. And as for case 4 is concerned, all are remained same as case 3 but the bypass spring which is set at designed spring constant to check how the result behaves. Finally, in case 5, the regulator is not used and the gas is fed directly from the bottle.

IV. RESULTS

The results shown in this section are the curves of door opening time with respect to pressure at different temperature and angular velocity with respect to opening angle. The cyan colored graph is a graph of the test performed at room temperature, brown colored at 50°C, red colored at -30°C, green colored at -40°C and black colored at -55°C.

Also two different silicon oil CST 50 and CST 100 for snubber are tested. At low temperature CST 50 performed well than CST 100 but at room temperature, the opening time while using CST 50 is very fast. Therefore, all the further tests

are performed with CST 100 type silicon oil.

In case 1, although at room temperature and 50°C, the opening time is well within the requirement, at low temperature like -40°C, the opening time is 9.7 s at 1000 psi. At -55°C, locking is noticed and no movement of the door is seen. Also, angular velocity is close to 1.6 rad/s which is slightly above the requirement. The opening time vs inlet pressure and angular velocity vs opening angle for this case is recorded in Fig. 7 and Fig. 8.

In order to check the effect of closed shaft orifice on opening time, test with case 2 is performed. In all the cases after 1, the amount of oil inside the snubber is also increased to avoid excessive foaming and problems caused due to air entrainment. Even though the opening time and angular velocity decreased significantly than case 1, still at -55°C, locking is observed. The graph for case 2 is plotted in Figs. 9 and 10.

In case 3, the opening time except at -55°C satisfied the time requirement with angular velocity slightly decreasing than in case 2. The curves are plotted in Figs. 11 and 12. During case 3, it is noticed that the bypass valve is locked due to weaker spring force and the gap is closed inadvertently. Thus, in case 4, the spring constant is set again to designed value and remaining condition is set as same as in case 3. The locking problem of the door at -55°C is countered. At -55°C and 1300 psi, the opening time is 7.8 s. The angular velocity however is increased close to 1.6 rad/s. It can be inferred from the curves in Figs. 8, 10, 12 and 14 that the damping doesn't occur in about first 20 degree movement of the door. If somehow damping can be produced during that movement, the angular velocity can be decreased. Checking the test parameters and the results, it can be concluded that bypass valve parameters when decreased results in reduction of angular velocity. The graph featuring case 4 is shown in Figs. 13 and 14.

For the final case, only the bottle is used to supply gas pressure without making use of the regulator to restrict pressure. The opening time at room temperature and 50°C is well within the requirement limit but as the temperature decreases, the opening time increases rapidly. Hence, it is concluded that regulator is required for this system to work properly.

V. CONCLUSIONS

It is concluded that within the studied parameters, the snubber piston orifice and shaft orifice of 0.3mm, bypass valve gap of 0.5 mm and spring constant set to original value gives the best result. In other cases, the door opening time requirement at temperature except at -55°C, when the pressure is above 1100 psi, is met. But at -55°C, the door failed to move and locked continuously. For case 4 with 1300 psi and with the usage of regulator, the door opening time requirement is satisfied at all temperature conditions. The angular velocity is slightly above the requirement but as can be observed from the graphs, changing the bypass valve parameters seem to decrease the angular velocity. Therefore, further research and

experiment need to be performed using bypass valve to validate the case.

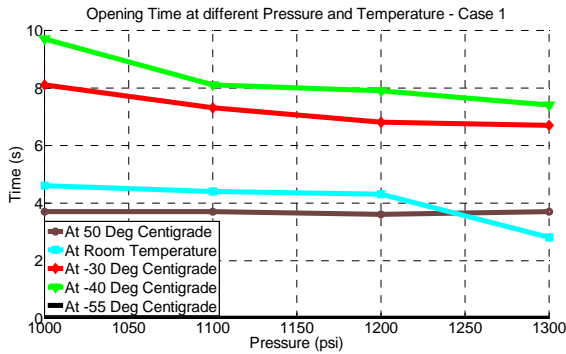

Fig. 7 Comparison of opening time with pressure change: case 1

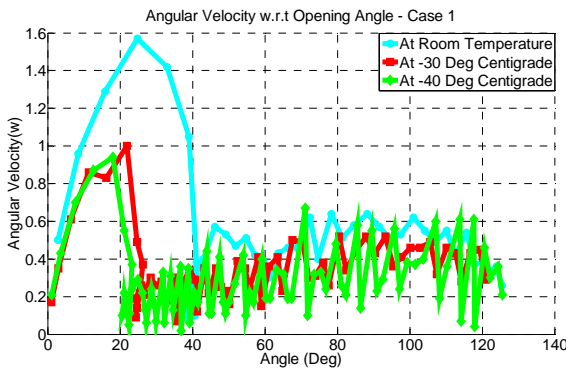

Fig. 8 Comparison of angular velocity with opening angle: case 1

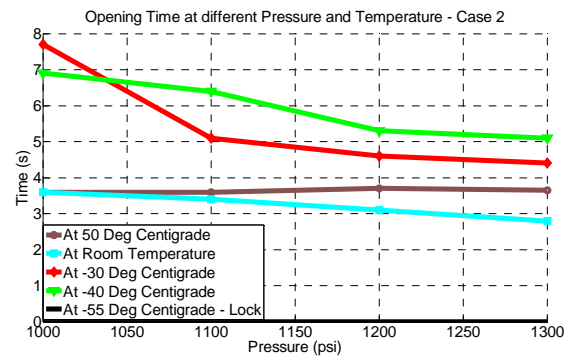

Fig. 9 Comparison of opening time with pressure change: case 2

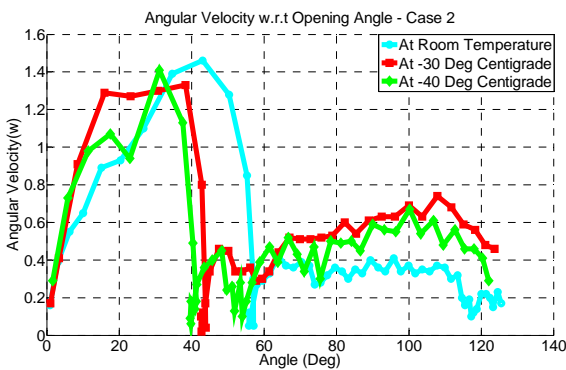

Fig. 10 Comparison of angular velocity with opening angle: case 2

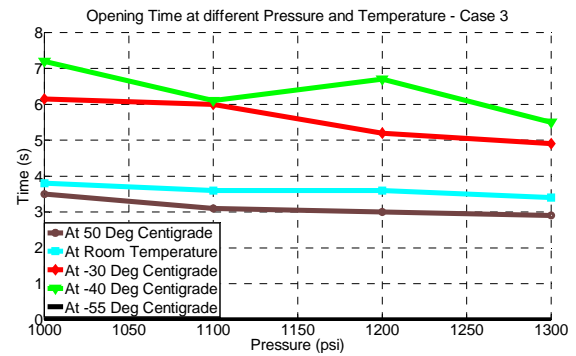

Fig. 11 Comparison of opening time with pressure change: case 3

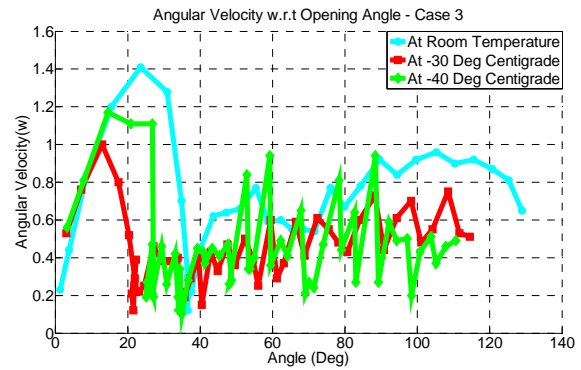

Fig. 12 Comparison of angular velocity with opening angle: case 3

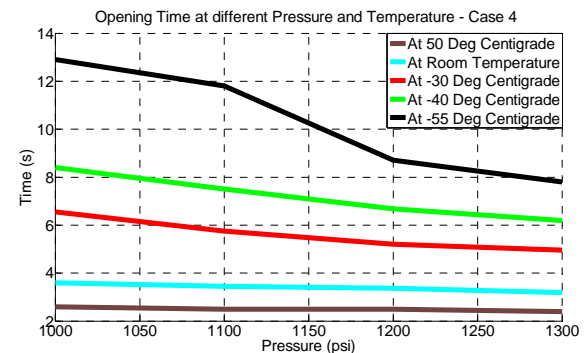

Fig. 13 Comparison of opening time with pressure change: case 4

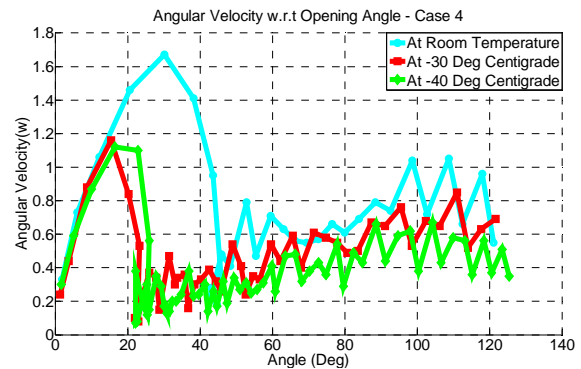

Fig. 14 Comparison of angular velocity with opening angle: case 4

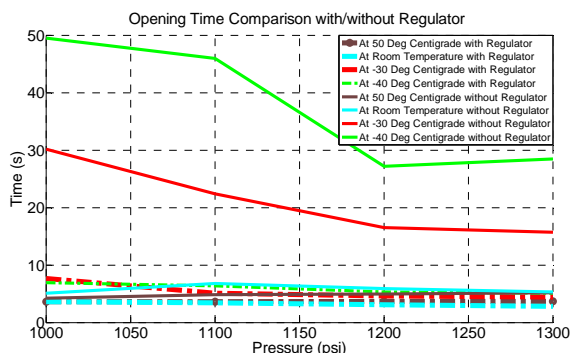

Fig. 15 Comparison of opening time with pressure change: with / without regulator

ACKNOWLEDGMENT

M.D. Kafle would like to thank Hyeon Beom Cho for his assistance in performing test and arranging the experimental data that made this experimental research paper possible.

REFERENCES

- [1] R.D. Eyres, "Modelling and Dynamic Response of a Damper with Relief Valve," Bristol Laboratory for Advanced Dynamic Engineering, University of Bristol, Elsevier Science, 2003.
- [2] D. Kress, "Emergency Opening System for an Aircraft Cabin Door", Eurocopter Deutschland GmbH, EP 2644495 A1.
- [3] M.D. Symans, "Passive Fluid Viscous Damping Systems for Seismic Energy Dissipation," ISET Journal of Earthquake Technology, Vol. 35, No. 4, 1998, pp185~206.
- [4] Y. Hou, L., "Shock Absorber Modeling and Simulation Based on Modelica," Proceedings 8th Modelica Conference, Dresden, Germany, 2011, pp 843~846.
- [5] N.V. Satpute, "Fluid Flow Modelling of a Fluid Damper with Shim Loaded Relief Valve," International Journal of Mechanical Engineering, Vol. 2, Issue 1, 2013, pp. 65~74.
- [6] M.P. Conner, "Hydraulic Snubber for Aircraft," The Boeings Company, Seattle, Washington. 1997.
- [7] G.E. Totten, "Handbook of Hydraulic Fluid Technology, Second Edition," CRC Press, 2011.
- [8] Y.C. Kwon, "Design of Throttle Orifices for an Aircraft Door Damper," 유공압건설기계학회논문집, Vol. 9, No. 3, 2012, pp 23~28.