

# Seismic Assessment of Old Existing RC Buildings with Masonry Infill in Madinah as per ASCE

Tarek M. Alguhane, Ayman H. Khalil, M. N. Fayed, Ayman M. Ismail

**Abstract**—An existing RC building in Madinah is seismically evaluated with and without infill wall. Four model systems have been considered i.e. model I (no infill), model IIA (strut infill-update from field test), model IIB (strut infill- ASCE/SEI 41) and model IIC (strut infill-Soft storey- ASCE/SEI 41). Three dimensional pushover analyses have been carried out using SAP2000 software incorporating inelastic material behavior for concrete, steel and infill walls. Infill wall has been modeled as equivalent strut according to suggested equation matching field test measurements and to the ASCE/SEI 41 equation. The effect of building modeling on the performance point as well as capacity and demand spectra due to EQ design spectrum function in Madinah area has been investigated. The response modification factor (R) for the 5 story RC building is evaluated from capacity and demand spectra (ATC-40) for the studied models. The results are summarized and discussed.

**Keywords**—Infill wall, Pushover Analysis, Response Modification Factor, Seismic Assessment.

## I. INTRODUCTION

**B**UILDINGS with masonry infill wall RC frames are the most common type of structures used for multistory constructions in the Western region of Saudi Arabia. The presence of the infill walls increases the lateral stiffness considerably. Due to the change in stiffness and mass of the structural system, the dynamic characteristics change as well. In several moderate earthquakes, such buildings have shown excellent performance during earthquake.

The Western region of Saudi Arabia lies in low to moderate seismicity regions and seismic events of magnitude 5.7 were recorded in 2009 in areas near the holy city of Madinah, Roobol [1], Al-Saud [2] and Aldamegh et al. [3]. Majority of the structures built in Saudi Arabia in the seismically active Western region are designed primarily for combination of gravity and wind loads and are not able to resist seismic loading. Non-ductile detailing practice employed in these structures makes them prone to potential damage and failure during earthquake. Therefore analysis of such buildings are required which have not been designed to take care of seismic forces.

The concrete frame structures provided with masonry panels are widely spread in many countries. In these

structures, exterior masonry walls and/or interior partitions, usually regarded as nonstructural architectural elements, are built as an infill between the frame members. The usual practice in the structural design of infill-frames is to ignore the structural interaction between the frame and infill. However, infill-frames have often demonstrated good earthquake-resistant behavior, at least for serviceability level earthquakes in which the masonry infill can provide enhanced stiffness and strength.

The seismic design of masonry in-filled RC frame buildings is handled in different ways across the world. The latest research studies about the infill-frame interaction, point out some difficulties related to the variety and uncertainty of the parameters involved, the complexity of the models and the experimental investigation. The scientific literature offers a variety of models, which can be grouped in two classes, Crisafulli et al. [4], [5], FEMA 356 [6], ASCE 41 [7], Asteris et al [8], Haris et al. [9] and Samoila [10]. The first one includes micro-modeling approaches, in which the RC frame, the masonry panel and their mutual connections are individually modeled and described by proper constitutive laws. The second class, usually defined as “macro-modeling approach”, is the most widely used, and the method of the “equivalent strut” is the most popular. Therefore, the infill-frame interaction has become a research focus for seismic analysis of buildings and there is a need to do more work in this field for local building in the Kingdom of Saudi Arabia.

ASCE/SEI 41 is a guideline providing assistance in seismic assessment and rehabilitation of reinforced concrete buildings with infill walls. The document is based on FEMA 356 and provides guidelines on assessment and rehabilitation of a wide range of building types. For masonry infill is modeled as the compression strut with possibility of forming axial hinge, as recommended by ASCE/SEI 41 for the calculations of strengths and effective stiffness of the infill panels.

In this paper, an existing RC building in Madinah is seismically evaluated with and without infill wall. 3D pushover analysis (Nonlinear static analysis) has been carried out using SAP2000 software [11] incorporating inelastic material behavior for concrete, infill and steel. The purpose of this analysis is to evaluate the expected performance of structural systems by estimating performance of a structural system, strength and deformation demands in design, and comparing these demands to available capacities at the performance levels of interest. The analysis is carried out up to failure, thus it enables determination of collapse load and ductility capacity. Four model systems have been considered i.e. model I (no infill), model IIA (strut infill-update from field

Tarek M. Alguhane is Doctor of structural, Madinah, KSA (phone: 00966505375200; e-mail: tarijuha@hotmail.com).

Ayman Hussin is Professor of Structural Engineering, Ain Shams University, Egypt (e-mail: ayman\_hh\_khalil@yahoo.com).

M. N. Fayed is Professor of Structural Engineering, King Saud University, KSA (e-mail: mnourf@yahoo.com).

Ayman M. Ismail is Professor of Structural Engineering, HBRC, Egypt, (e-mail: ayman.m.ismail@gmail.com).

test), model IIB (strut infill- ASCE/SEI 41) and model IIC (strut infill-Soft storey-ASCE/SEI 41). The results are summarized and discussed.

## II. PUSHOVER ANALYSIS METHODS

A pushover analysis is performed by subjecting a structure to a monotonically increasing pattern of lateral loads, representing the inertial forces which would be experienced by the structure when subjected to ground shaking. Under incrementally increasing loads various structural elements may yield sequentially. Consequently, at each event, the structure experiences a loss in stiffness. Using a pushover analysis, a characteristic nonlinear force displacement relationship can be determined.

### A. Plastic Deformation Curve

A representation of the monotonic load-deformation relationship is given in Fig. 1. The values of the deformations (or rotations) at the points B, C and D should be derived from experiments or rational analysis. Three points labeled IO (Immediate Occupancy), LS (Life Safety) and CP (Collapse Prevention) are used to define the acceptance criteria for the hinge. The recommended plastic rotation capacities for RC columns and beams controlled by flexure are given ATC-40 [12] and FEMA 356 (adapted from ASCE 2000).

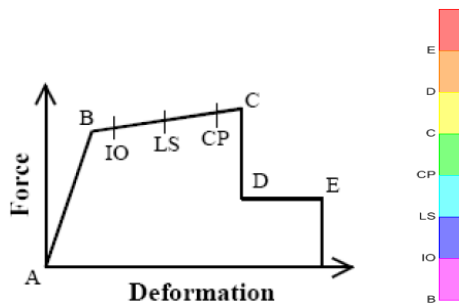

Fig. 1 Generalized force-deformation relation for concrete elements or components

### B. Nonlinear Static Procedures in Current Standards

Simplified Nonlinear Static (Pushover) procedures for buildings have been presented in the ATC-40 and FEMA-273, 356, 440 [13], [6], [14] to determine the displacement demand imposed on a building expected to deform inelastically.

Displacement Coefficient Method (DCM) of FEMA-273 [13] has also been enhanced to Displacement Modification Method (DMM) in FEMA-440 [14]. The displacement coefficient method generates an estimate of the maximum global displacement, called the target displacement, by modifying the linear elastic response of an equivalent SDOF system. This is accomplished by multiplying the SDOF spectral displacement by a series of coefficients, C0 through C3.

Capacity Spectrum Method of ATC-40 has been modified in FEMA-440 and stated as Equivalent Linearization Method (ELM). The initial step in the capacity spectrum method (as

used in ATC-40) is the same as in the displacement coefficient method: generate a pushover curve for the structure. However, in the capacity spectrum method, the results are plotted in acceleration-displacement response spectrum (ADRS) format, shown in Fig. 2. To plot the pushover in ADRS format (called a capacity curve), the base shear versus roof displacement relationship must be converted using the dynamic properties of the system. The ground motion acceleration response spectrum, representing the seismic demand, is also converted to ADRS format, so that the capacity curve can be plotted on the same axes as the seismic demand. It is important to note that in ADRS format, period is represented by radial lines emanating from the origin.

Once the pushover curve and response spectrum are plotted together in ADRS format, iteration is required to determine the maximum inelastic displacement, called the performance point.

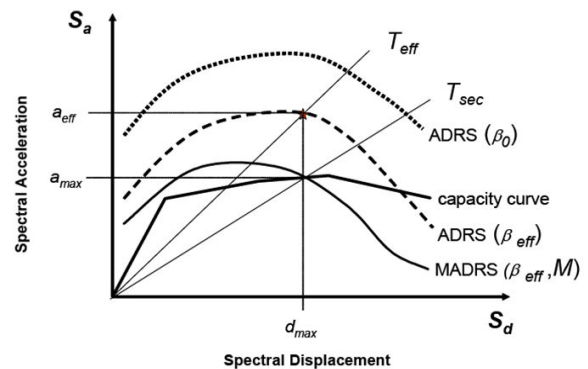

Fig. 2 Graphical representation of the capacity spectrum method, ATC-40 [12], FEMA 440 [14]

### C. Response Modification Factor, R

The philosophy of earthquake resistant design is that a structure should resist earthquake ground motion without collapse, but with some damage. Consistent with this philosophy, the structure is designed for much less base shear forces than would be required if the building is to remain elastic during severe shaking at a site. Such large reductions are mainly due to two factors: (1) the ductility reduction factor ( $R_\mu$ ), which reduces the elastic demand force to the level of the maximum yield strength of the structure, and (2) the over-strength factor, ( $\Omega$ ), which accounts for the over-strength introduced in code-designed structures, ATC-19 [15]. Thus, the response reduction factor ( $R$ ) is simply  $\Omega$  times  $R_\mu$ , Fig. 3.

$$R = R_\mu \times \Omega \quad (1)$$

The ductility reduction factor ( $R_\mu$ ) is a factor which reduces the elastic force demand to the level of idealized yield strength of the structure and, hence, it may be represented as the following equation:

$$R_\mu = V_e / V_y \quad (2)$$

$V_e$  is the max base shear coefficient if the structure remains elastic. The ductility reduction factor ( $R_\mu$ ) takes advantage of

the energy dissipating capacity of properly designed and well-detailed structures and, hence, primarily depends on the global ductility demand,  $\mu$ , of the structure ( $\mu$  is the ratio between the maximum roof displacement and yield roof displacement).

The ductility dependent component,  $R_{\mu}$ , has received considerable attention. Reviews of these discussions can be seen in works by Uang [16], Kappos [17], Mwafy and Elnashai [18]. Ductility reduction factor  $R_{\mu}$  is a function of both characteristics of the structure including ductility, damping and fundamental period of vibration ( $T$ ), and the characteristics of earthquake ground motion, Maheri and Akbari [19]. Miranda and Bertero [20] presented below equations using 124 ground motions recorded on a wide range of soil conditions, and assumed five percent of critical damping. Their equation for the ductility factor is given as.

$$R_{\mu} = \frac{\mu - 1}{\phi} + 1 \quad (3)$$

where  $\phi$  is a function of  $T$ ,  $\mu$ , and site soil characteristics.

Equation (3) can be used to deduce relationship for short to medium-period (i.e.,  $0.25 < T < 0.70$  sec.) (Miranda and Bertero, [20]):

$$R_{\mu} = \sqrt{2\mu - 1} \quad (4)$$

The over-strength factor ( $\Omega$ ) may be defined as the ratio of actual to the design lateral strength, Fig. 3:

$$\Omega = V_y / V_d \quad (5)$$

where  $V_y$  is the base shear coefficient corresponding to the actual yielding of the structure;  $V_d$  is the code-prescribed unfactored design base shear coefficient.

### III. MODELLING INFILL WALLS AS STRUTS FOR IN-FILLED RC FRAMES

#### A. ASCE/SEI 41

For masonry infill is modeled as the compression strut as recommended by ASCE/SEI 41 for the calculations of strengths and effective stiffness of the infill panels. The infill is modeled as single strut element with possibility of forming axial hinge, Fig. 4. ASCE/SEI 41 gives the following equation for the calculation of the width ( $a_1$ ) of the equivalent compression strut that represents the in-plane stiffness of a solid un-reinforced masonry infill panel before cracking:

$$a_1 = 0.175(\lambda_1 h_{col})^{-0.4} r_{inf} \quad (6)$$

where,

$$\lambda_1 = \left[ \frac{E_{me} t \sin 2\theta}{4E_c I_c h_{inf}} \right]^{1/4}$$

$h_{col}$  = Column height between centre lines of the beams;  $h_{inf}$  = Height of the infill panel;  $E_c$  = Expected modulus of elasticity of the frame material;  $E_{me}$  = Expected modulus of elasticity of the infill material;  $I_c$  = Moment of inertia of the column;  $L_{inf}$  =

Length of the infill panel;  $r_{inf}$  = Diagonal length of the infill panel;  $t$  = Thickness of the infill panel and equivalent strut;  $\theta$  = Angle whose tangent is the infill height-to length aspect ratio.

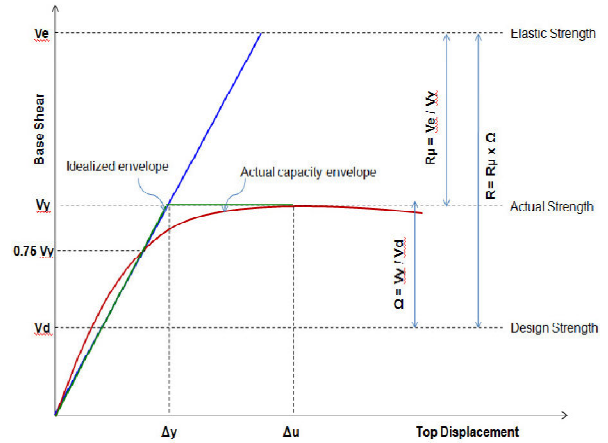

Fig. 3 Relationship between force reduction factor ( $R$ ), structural over-strength ( $\Omega$ ), and ductility reduction factor ( $R_{\mu}$ )

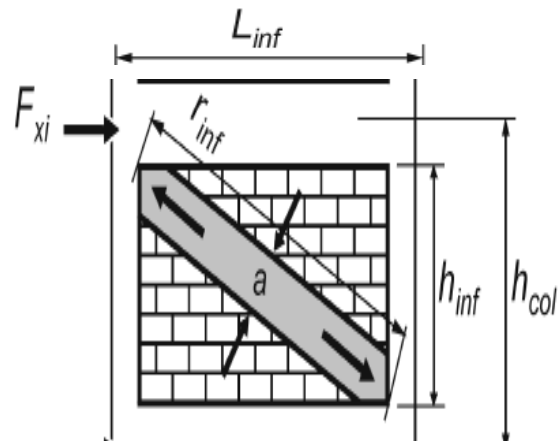

Fig. 4 Compression strut analogy—concentric Struts, ASCE/SEI 41[7]

#### B. NBCC 2005

NBCC 2005 [21] gives the following equation for the calculation of the Diagonal strut width  $w$  as follows, Fig. 5:

$$w = \sqrt{\alpha_h^2 + \alpha_L^2} \quad (7)$$

where

$$\alpha_h = \frac{\pi}{2} \left[ \frac{4E_f I_c h}{E_m t_e \sin 2\theta} \right]^{1/4} \quad \alpha_L = \pi \left[ \frac{4E_f I_b l}{E_m t_e \sin 2\theta} \right]^{1/4}$$

$\alpha_h$  = vertical contact length between the frame and the diagonal strut,  $\alpha_L$  = horizontal contact length between the frame and the diagonal strut,  $E_m$ ,  $E_f$  = modulus of elasticity of the masonry wall and frame material, respectively,  $h$ ,  $l$  = height and length of the infill wall, respectively,  $t_e$  = sum of the thickness of the two face shells for hollow or semi-solid block units and the thickness of the wall for solid or fully grouted hollow or semi-solid block units,  $I_c$ ,  $I_b$  = moments of inertia of the column and the beam of the frame respectively,  $\theta$

= angle of diagonal strut measured from the horizontal,  $d$  = diagonal length of the infill panel.

Effective diagonal strut width,  $w_e$ , to be used for the calculation of the compressive strength of the strut should be taken  $w_e = w/2$  or  $l_s/4$ , whichever is the least.

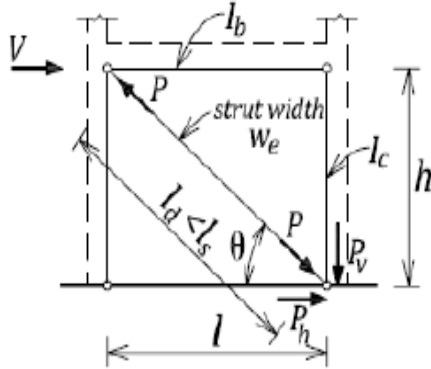

Fig. 5 Diagonal strut model, NBCC 2005 [21]

### C. Proposed Equation for Modeling of Infill of RC Building,

In case of the cross diagonal struts, the axial stiffness coefficient  $E_{strut} A_{strut}$  can be expressed in terms of the shear stiffness  $G_w A_w$  of the infill panel and the inclination ( $\theta$ ) of the strut from:

$$2 (E_{strut} \cdot A_{strut}) = G_w \cdot A_w / (\cos 2\theta \cdot \sin \theta) \quad (8)$$

Using the relation between the axial stiffness of the strut and the shear stiffness of the panel, the axial stiffness coefficient  $E_{strut} A_{strut}$  can be determined.

Alguhane suggested [22] that the above equation can be approximately satisfied by two assumptions:

- The width of the struts calculated according to the limitation of Canadian, (7), NBCC (2005) [21].
- The modulus of elasticity of the masonry wall,  $E_m$  and the shear modulus,  $G_w$  are calculated such as  $E_m = 550f_m$  and the shear modulus,  $G_w = 0.40 \cdot E_m$

Where,  $f_m$  is the compressive strength of the masonry wall material, ASCE 41 [7] and Euro-code 6 [23].

Then, calculate the required value of  $E_{strut}$  which satisfy the traditional structural equation(8).

### IV. PUSHOVER ANALYSIS IN SAP2000 [11]

Pushover analysis is a very powerful feature offered only in the non-linear version of SAP2000. The program is capable of including material nonlinearity in the form of plastic hinges in the frame elements, and geometric nonlinearity through P- $\Delta$  effects or considering large displacements.

SAP2000 program works with complex geometry and monitors deformation at all hinges to determine ultimate deformation. It has built-in defaults for ACI 318 material properties and ATC-40 and FEMA 356 hinge properties. The analysis in SAP2000 involves the following four steps.1) Modeling, 2) Static analysis, 3) Designing, 4) Pushover analysis, [24]-[27].

The following steps are included in the pushover analysis.

1. Create the basic computer model in the usual manner.
2. Define properties and acceptance criteria for the pushover hinges. The program includes several built-in default hinge properties that are based on average values from ATC-40 and FEMA 356 for RC Beam-Column frames.
3. Locate the pushover hinges on the model by selecting one or more frame members and assigning them one or more hinge properties and hinge locations.
4. Define the pushover load cases. More than one pushover load case can be run in the same analysis. Typically, a gravity load pushover is force controlled and lateral pushovers are displacement controlled.
5. Run the basic static analysis and, then run the static nonlinear pushover analysis.
6. Display the pushover curve, table and the pushover displaced shape and sequence of hinge formation on a step-by-step basis.

TABLE I  
MATERIAL PROPERTIES FOR BUILDING

Concrete strength	20000 kN/m <sup>2</sup>	F'c
Rebar yield strength	243700 m <sup>2</sup>	Fy
Modulus of elasticity of concrete	20000000 kN/m <sup>2</sup>	Ec
Modulus of elasticity of rebar	2.0E+8 kN/m <sup>2</sup>	Es
Shear modulus	10356491 kN/m <sup>2</sup>	G
Poisson's ratio	0.2	Y

### V. APPLICATION TO FIVE-STORY RC BUILDING

#### A. Description

The structure is an existing five-story reinforced concrete moment frame building in Madinah City. It is representative of old building type constructed in Madinah City before 30 years ago. The function of this building is hotel use only. These buildings types are almost consisting of reinforced concrete skeleton i. e. columns, beams and solid slab. The thickness of brick walls are almost equal 0.12 m and the storey height is about 3.00 m. The picture of the building is shown in Fig. 6. Figs. 7 and 8 show plan and elevation for building dimensions. Material properties for the building are illustrated in Table I. These properties were obtained from test on drilled concrete core specimens.



Fig. 6 View of the Case Study Building in Madinah

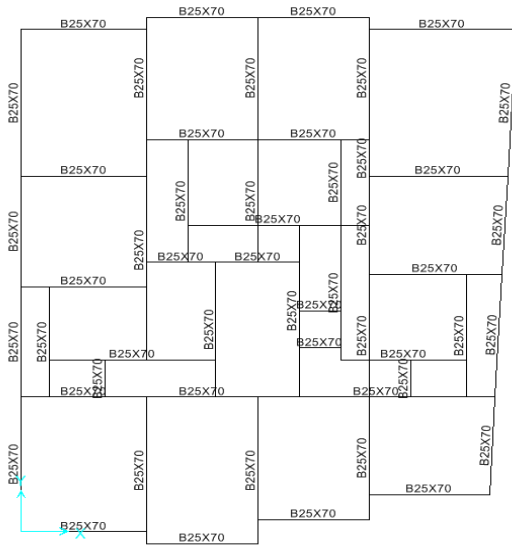

Fig. 7 Typical Plan



Fig. 8 Elevation

The dynamic characteristics of this 5-storey building have been compared with measured values in the field. After, updated the mathematical models for this building to match the experimental results, the lateral load pattern in Madinah City corresponding to the Saudi Building Code - Structural requirements for Loads and Forces - (SBC 301 [28]) is adopted and applied as auto lateral load pattern in SAP 2000. The inelastic material behaviors for concrete infill and steel have been implemented in the analysis.

### B. Loading Assumptions

- 1) Total Dead Load (D) is equal to DL+SDL+CL
- 2) Dead Load (DL) is equal to the self-weight of the members and slabs.
- 3) Super-imposed Dead Load (SDL) is equal to 3.0 kN/m<sup>2</sup>. SDL includes partitions, ceiling weight, and mechanical

loads.

- 4) Cladding Load (CL) is applied only on perimeter beams.
- 5) Live Load (L) is equal to 2.0 kN/m<sup>2</sup>.

Table II shows the total static loads for RC building due to EQ and Wind load cases according to Saudi Code for Loads and Forces - (SBC 301) [28]. The results in this table show that the EQ loads are the dominant in design.

TABLE II  
BASE SHEAR AND TARGET DISPLACEMENT VALUES FOR THE FOUR MODELS

Case	Target Value	Model I (no infill)	Model IIA (strut field test)	Model IIB ASCE/SEI	Model IIC Softstorey ASCE/SEI
Case x-	V <sub>b</sub> (kN)	7056	10178	8823	5677
x	δ <sub>i</sub> (m)	0.243	0.026	0.077	0.059
Case y-	V <sub>b</sub> (kN)	11140	14954	14260	11659
y	δ <sub>i</sub> (m)	0.099	0.027	0.071	0.057

### C. Scope of Models

- i. *Model I*: This model considers the primary lateral-resisting system of the structure as well as flooring slabs, Fig. 9.
- ii. *Model IIA*: (strut infill-update model from Field test), This model is developed from Model I by add modeling of infill walls as strut model according to suggested limitation from field test, Alguhane [22]. Equivalent strut width  $w$  according to suggested limitation to (7) ( $w=0.25d$ ), and  $E_{strut}$  in the range of  $4.1E+6$  kN/m<sup>2</sup>, (8),
- iii. *Model IIB*: (strut infill- ASCE/SEI 41), This model is also developed from Model I by add modeling of infill walls as strut model according to suggested limitation to ASCE/SEI 41. Equivalent width  $w$  according to ASCE/SEI 41 in the range of  $w=0.10d$  and  $E_{strut}=E_{infill} = 2.4 E+6$  kN/m<sup>2</sup>.
- iv. *Model IIC*: (strut infill-Soft storey-ASCE/SEI 41), This model is similar to Model IIB but strut infill walls from the ground floor from Model IIB have been removed. The resultant has been used to study the effect of soft storey on the seismic behavior of this building.

Figs. 9 and 10 show three-dimensional representations for the studied models.

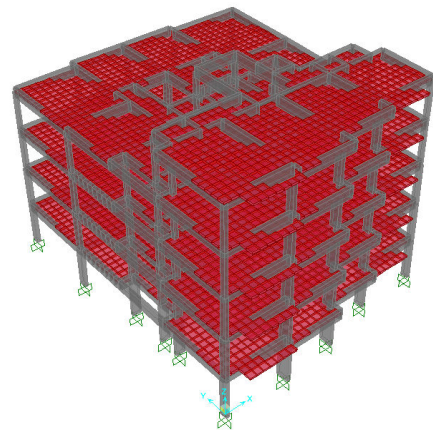

Fig. 9 Model I (no infill)

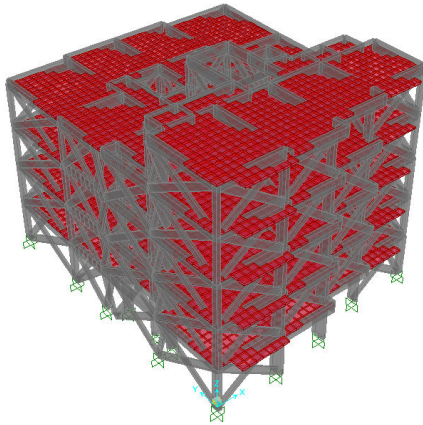

Fig. 10 Models II A, II B, II C (strut infill)

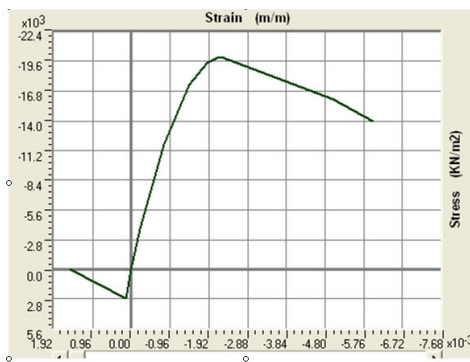

Fig. 11 (a) Stress-strain curve for concrete

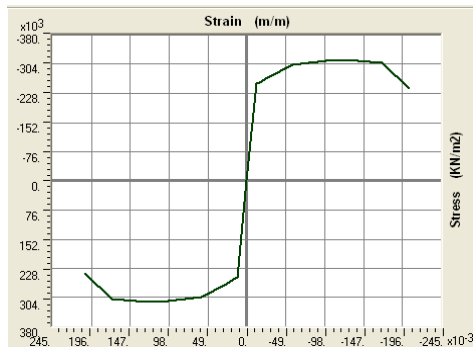

Fig. 11 (b) Stress-strain curve for steel bars

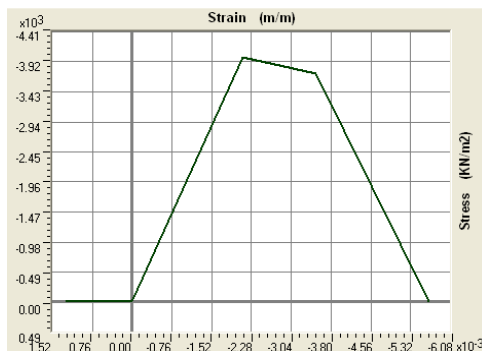

Fig. 11 (c) Stress-strain curve for clad brick

Fig. 11 Stress-strain curves for Building

Stress-strain curves for concrete, steel bars and brick wall are illustrated in Fig. 11.

### III. RESULTS AND DISCUSSIONS

The nonlinear static analytical procedure (Pushover) was applied for the evaluation of existing 5-storey RC old type building. The static nonlinear analysis combined the application of the dead load followed by the application of the lateral seismic forces, which were increased up to failure under displacement control. The effect of modeling the building without infill walls, (Model I) and with infill walls as equivalent truss model according to (8) (Model IIA), and to ASCE/SEI 41 (6) (Model IIB and Model IIC) on the performance point as well as capacity and demand spectra has been investigated.

#### A. Hinge Status at Target Displacement for Pushover Analysis of RC Building

Displacement-controlled pushover analyses were performed on four models for 5-storey RC building. The structural performance level of a building is categorized essentially in three discrete levels and two intermediate structural performance ranges. The discrete structural performance levels are immediate occupancy (IO), life safety (LS), and collapse prevention (structural stability) (CP). The two intermediate structural performance ranges are the damage control range and the limited safety range. Figs. 12 and 13 show hinge formations for building, Model I, no infill and Models IIA, IIB, IIC, strut infill with different assumptions, in x and y directions respectively.

From the above figures, it is observed that:

- The performance level of the bare frame Model I (no infill) and Model IIC (strut infill-Soft storey-ASCE/SEI 41) are mainly in IO-C range (i.e. Immediate occupancy to collapse range) whereas, Model IIA (strut infill-update model from field test) and Model IIB (strut infill-ASCE/SEI 41) are mainly in B – LS (i.e. operational range to life safety range).
- From the Isometric shape for hinge status at target displacement, the performances of structure with masonry infill wall, (strut infill-update model from field test) and Model IIB (strut infill- ASCE/SEI 41), are improved after modeling the masonry infill walls as compared to bare frame, Model I.
- The soft storey in ground floor, Models IIC (strut infill-Soft storey-ASCE/SEI 41) is significantly affect column hinge formulation in the ground floor. Plastic hinges for columns are concentrated at lower stories and in immediate occupancy to collapse range, which is a not acceptable criterion for hinges.

#### B. Base Shear and Target Displacement Values

Fig. 14 shows the pushover curves up to failure for the four studied models in X direction and in Y direction respectively. The maximum base shear ( $V_b$ ) and target displacement ( $\delta_t$ ) values for the four different models are summarized in Table II. The maximum base shear capacity in x and y directions is

plotted as bar line for the four models as shown in Fig. 15. The results are summarized in Table II.

From the above figures and table, it is observed that:

*For Model I:* (no infill): The performance base shear V performance is 1080 kN and 1538 kN in X and Y directions respectively.

*For Model IIA:* (strut infill-update model from Field test), the performance base shear V performance is 2950 kN and 3470 kN in X and Y directions respectively.

*For Model IIB:* (strut infill- ASCE/SEI 41), the performance base shear V performance is 2950 kN and 3470 kN in X and Y directions respectively.

*For Model IIC:* (strut infill-Soft storey-ASCE/SEI 41), the performance base shear V performance is 2950 kN and 3470 kN in X and Y directions respectively.

- Maximum base shear capacity for both in-filled frame, Model IIA (strut infill-update model from field test) and Model IIB (strut infill- ASCE/SEI 41), are significantly increased than bare frame Model I (no infill) due to the presence of infill. However, for Models IIC (strut infill-Soft storey-ASCE/SEI 41) with soft storey in ground floor, the maximum base shear capacity is almost equal or less than the corresponding values in case of frame without infill walls, Model I (no infill). This shows the bad effect of removing infill walls in any storey of the building (soft storey) especially ground floor as usually done by the owner on reducing the maximum shear capacity. Consequently, the seismic safety factor is greatly reduced.
- Maximum displacement capacity for bare frame Model I (no infill) is considerably greater than frame with masonry infill, i.e, Model IIA (strut infill-update model from field test), Model IIB (strut infill- ASCE/SEI 41) and Model IIC (strut infill-Soft storey-ASCE/SEI 41). The presence of infill significantly increases the stiffness of the frame and the displacement capacity decreases, which is evident from the displacement profiles in these figures.

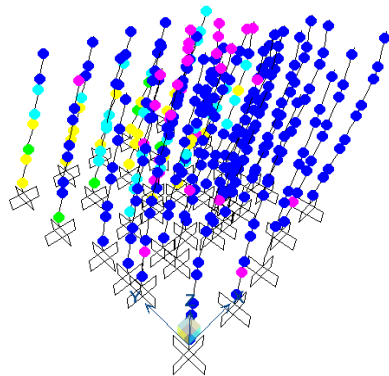

Fig. 12 (a) Model I (no infill)

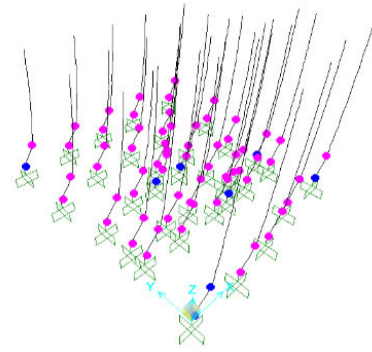

Fig. 12 (b) Model IIA (strut infill-update model from Field test)

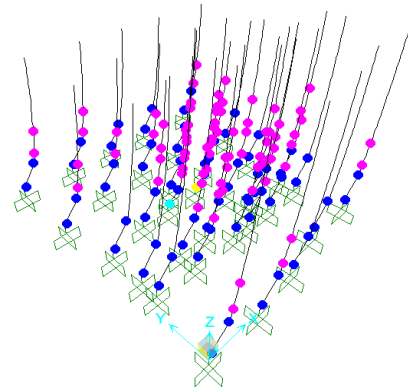

Fig. 12 (c) Model IIB (strut infill- ASCE/SEI 41)

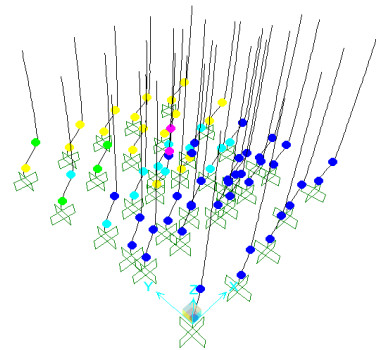

Fig. 12 (d) Model IIC (strut infill-Soft storey-ASCE/SEI 41)

Fig. 12 Columns Isometric shape for Hinge status at target displacement, static nonlinear analysis XX

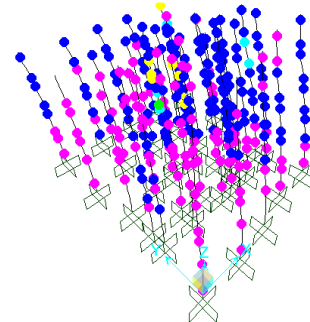

Fig. 13 (a) Model I (no infill)

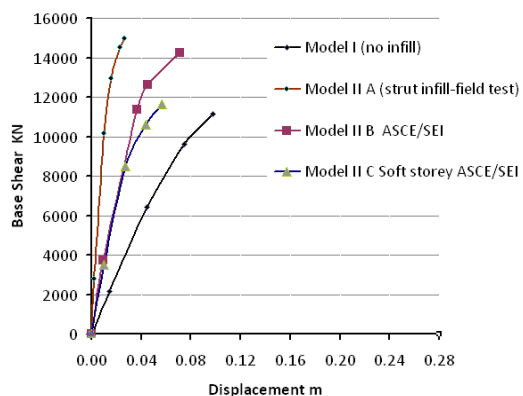
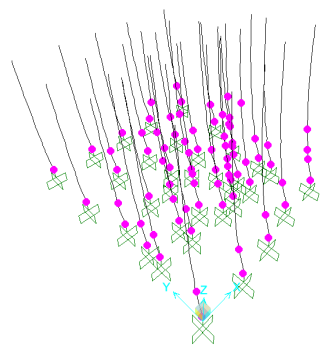

Fig. 14 Comparison of pushover curves for the four models

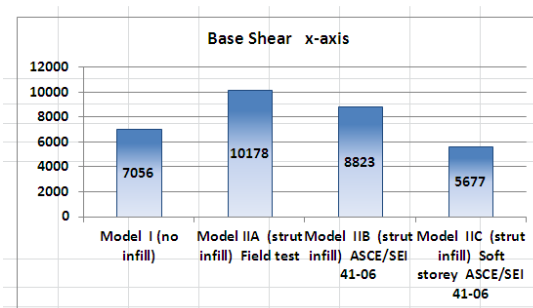
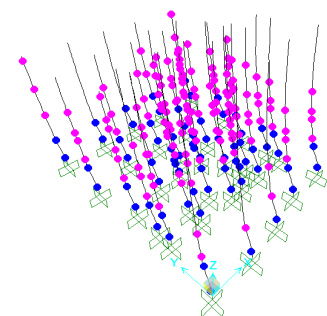

Fig. 15 (a) Base shear X-X

Fig. 13 (c) Model IIB (strut infill- ASCE/SEI 41)

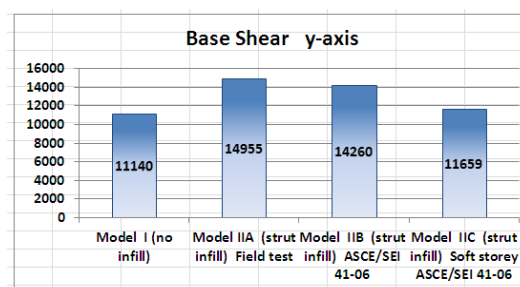
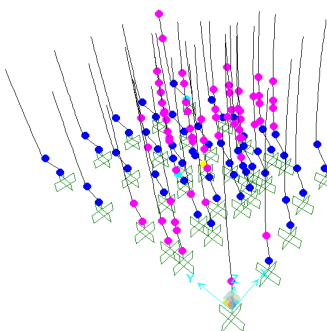

Fig. 15 (b) Base shear Y-Y

Fig. 13 (d) Model IIC (strut infill-Soft storey-ASCE/SEI 41)

Fig. 13 Columns Isometric shape for Hinge status at target displacement, static nonlinear analysis YY

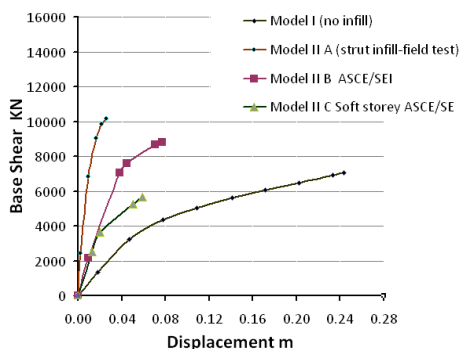

Fig. 14 (a) Static nonlinear analysis X-X

Fig. 15 Comparison of base shear for the four models

*C. Response Reduction Factor R from Capacity and Demand Spectra*

The response modification factor (R) for the 5 story RC building is evaluated from capacity and demand spectra (ATC-40). The capacity diagram and the demand diagram are shown in Figs. 16 and 17 in x and y directions for Model I Model IIA, Model IIB and Model IIC respectively. Further, the response modification factor (R) in x and y directions for Model I Model IIA, Model IIB and Model IIC are plotted in Fig. 18. The results, summarized in Tables III, IV and V, show that:

*For Model I: (no infill)*

- The values of the elastic strength  $R_u$  and Over-strength factor  $\Omega$  are 1.0 and 2.04 in X-direction and 1.0 and 2.96 in Y-direction respectively.
- The lowest resultant response reduction factor R equals



2.04.

For Model IIA: (strut infill-update model from Field test),

- The values of the elastic strength  $R_u$  and Over-strength factor  $\Omega$  are 1.0 and 4.55 in X-direction and 1.0 and 5.05 in Y-direction respectively.
- The lowest resultant response reduction factor R equals 4.55.

For Model IIB: (strut infill- ASCE/SEI 41),

- The values of the elastic strength  $R_u$  and Over-strength factor  $\Omega$  are 1.0 and 2.51 in X-direction and 1.0 and 3.92 in Y-direction respectively.
- The lowest resultant response reduction factor R equals 2.51.

For Model IIC: (strut infill-Soft storey-ASCE/SEI 41),

- The values of the elastic strength  $R_u$  and Over-strength factor  $\Omega$  are 1.0 and 2.21 in X-direction and 1.0 and 3.61 in Y-direction respectively.
- The lowest resultant response reduction factor R equals 2.21.

From the above figures and table, it is observed for the studied building that:

- Seismic evaluation of this type of building indicates that modeling the building as skeleton frame elements does not satisfy the code requirements for response modification factor (2.5 according to Saudi Building Code SBC 301). However, including infill wall in the analysis, increase the stiffness of the building and give higher value of response modification factor and Over-strength factor satisfying the code requirements.
- The seismic behavior of 5 storey RC building is significantly altered by the presence of infill walls, (Model IIA, Model IIB and Model IIC). Stiffness, strength, deformation capacity, ductility and failure mode are affected greatly by the frame-infill wall interaction.
- The assessment and rehabilitation of reinforced concrete buildings with infill walls according to updated model IIA from field measurements and according to the ASCE/SEI 41 Model IIB give increase the stiffness of the building and give higher value of R satisfying the code requirements. The response modification factors R for Model I without infill and Model IIA and Model IIB with infill are 2.04, 4.55 and 2.51 in x direction and 2.96, 5.05 and 3.92 respectively.
- The assessment and rehabilitation of reinforced concrete buildings with infill walls according the ASCE/SEI 41, Model IIB and Model IIC (with soft ground storey) show the effect of soft storey in reducing the stiffness of the building and give lower value of R. The response modification factors R for Model IIB and Model IIC are 2.51 and 2.21 in x direction and 3.92 and 3.61 respectively. This shows that R value in x direction does not satisfy the code requirements in case of complete ground soft storey for the studied building.

The above results show that the assessment and rehabilitation of reinforced concrete old type buildings are generally in safe condition due to EQ spectrum in Madinah area when considering at least the presence of infill walls

according to ASCE/SEI 41 code. Also, the study shows the important of the presence of infill walls in ground floor for improving the seismic evaluation of the building.

TABLE III  
RESULTS OF PUSHOVER ANALYSIS ACCORDING TO ATC-40, X-AXIS  
DIRECTION

item	Model I	Model IIA	Model IIB	Model IIC
	(no-infill)	Field test	ASCE/SEI 41 (strut-infill)	Soft storey ASCE/SEI 41
$S_a$	0.053	0.132	0.095	0.076
$S_d$	0.011	0.004	0.006	0.008
W (kN)	25613	25613	25613	25613
$V_p$ (kN)	1080	2950	2088	1770
Dp (m)	0.013	0.0055	0.009	0.009
Du(m)	0.1850	0.038	0.076	0.059
$B_{eff}$	0.05000	0.05300	0.05	0.05
$T_{eff}$ (s)	0.92900	0.33500	0.53	0.65
$V_y$ (kN)	1780	7020	3320	2920
$V_d$ (kN)	873	1540	1320	1320
$D_y$	0.023	0.0158	0.016	0.0155
$\mu$	1.00	1.00	1.00	1.00
$\Omega$	2.04	4.55	2.51	2.21
$R_u$	1.00	1.00	1.00	1.0
R	2.04	4.55	2.51	2.21

TABLE IV  
RESULTS OF PUSHOVER ANALYSIS ACCORDING TO ATC-40, Y-AXIS  
DIRECTION

item	Model I	Model IIA	Model IIB	Model IIC
	(no-infill)	Field test	ASCE/SEI 41 (strut-infill)	Soft storey ASCE/SEI 41
$S_a$	0.0800	0.15600	0.118	0.111
$S_d$	0.0074	0.00320	0.0051	0.0057
W (kN)	25613	25613	25613	25613
$V_p$ (kN)	1538	3470	2515	2340
Dp (m)	0.010	0.0042	0.0065	0.0068
Du(m)	0.103	0.0281	0.076	0.057
$B_{eff}$	0.05000	0.05200	0.05	0.05
$T_{eff}$ (s)	0.61400	0.2800	0.417	0.454
$V_y$ (kN)	2590	8890	5180	4760
$V_d$ (kN)	873	1760	1320	1320
$D_y$	0.0171	0.0134	0.015	0.014
$\mu$	1.00	1.00	1.00	1.0
$\Omega$	2.96	5.05	3.92	3.61
$R_u$	1.00	1.00	1.00	1.00
R	2.96	5.05	3.92	3.61

TABLE V  
SYMBOL AND Quantity

Symbol	Quantity	Notes
$S_a$	Response spectrum acceleration	(Figs. 16 and 17)
$S_d$	Response spectrum displacement	(Figs. 16 and 17)
W (kN)	Weight of the building	Calculated
$V_p$ (kN)	V performance	(Figs. 16 and 17)
Dp (m)	D performance	(Figs. 16 and 17 )
Du (m)	ultimate displacement	(ATC-40 (8)-(4))
$B_{eff}$	Effective viscous damping	(ATC-40 (8)-(15))
$T_{eff}$ (s)	Effective period	(FEMA 356 (2)-(12))
$V_y$ (kN)	First Yield base shear	Calculated
$V_d$ (kN)	Design base shear	Calculated
$D_y$	First Yield displacement	(Figs. 16 and 17 )
$\mu$	Ductility	(FEMA 440 (6)-(19))
$\Omega$	Over-strength factor	$\Omega = V_y / V_{design}$
$R_u$	Ratio of the elastic strength	Equation (2)
R	Response reduction factor	$R = R_u * \Omega$

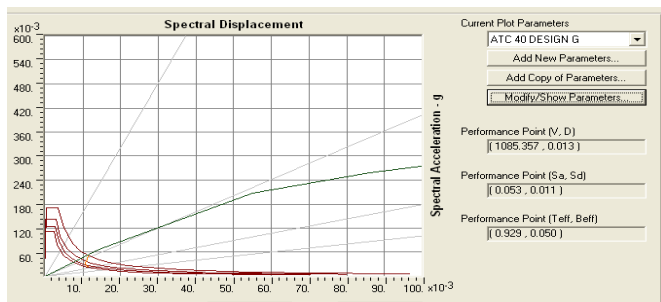

Fig. 16 (a) Model I (no infill), R=2.04

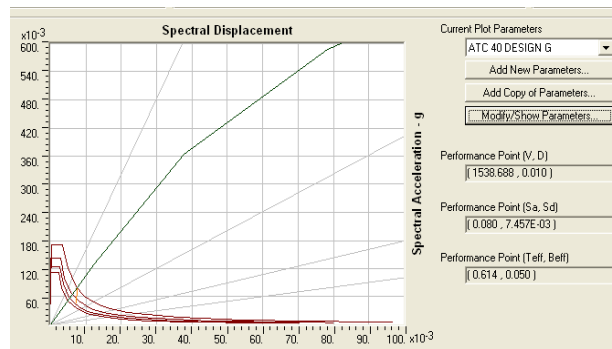

Fig. 17 (a) Model I (no infill), R=2.96

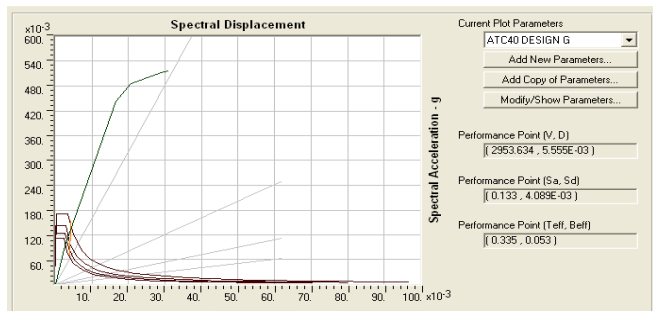

Fig. 16 (b) Model IIA (strut infill-update model from Field test), R=4.55

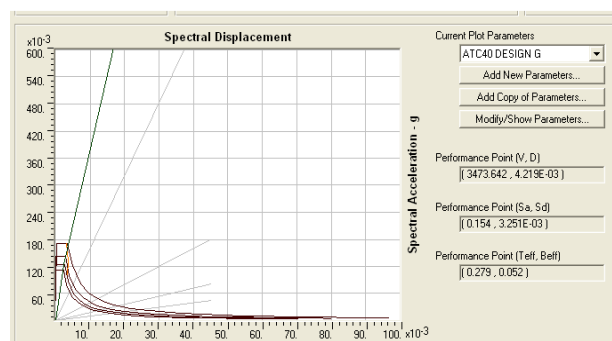

Fig. 17 (b) Model IIA (strut infill-update model from Field test), R=5.05

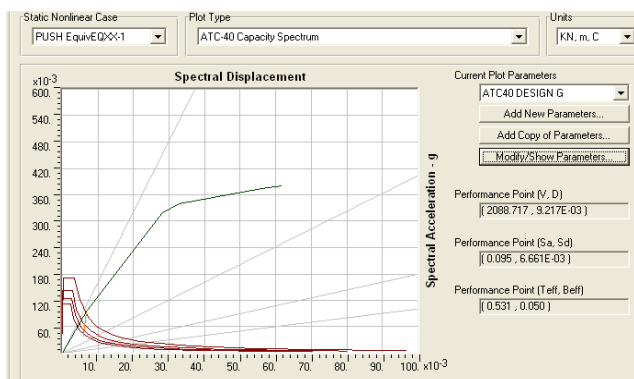

Fig. 16 (c) Model IIB (strut infill- ASCE/SEI 41), R=2.51

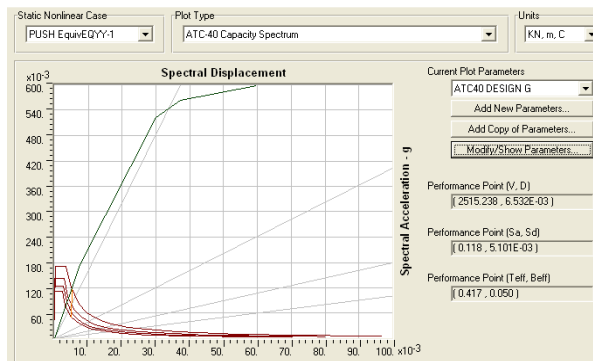

Fig. 17 (c) Model IIB (strut infill- ASCE/SEI 41), R=3.92

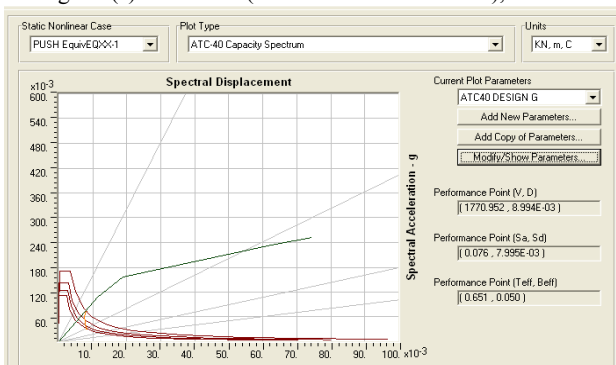

Fig. 16 (d) Model IIC (strut infill-Soft storey-ASCE/SEI 41), R=2.21

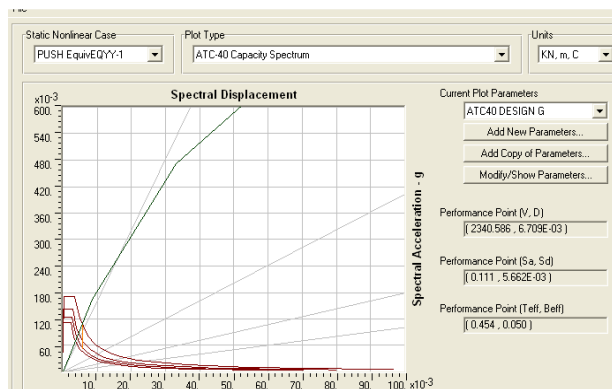

Fig. 17 (d) Model IIC (strut infill-Soft storey-ASCE/SEI 41), R=3.61

Fig. 16 ATC40 Capacity spectrum, EQX, design spectrum function in Madinah

Fig. 17 ATC40 Capacity spectrum, EQY, design spectrum function in Madinah

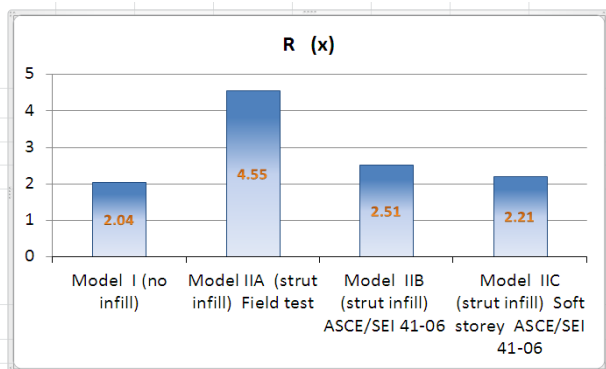

Fig. 18 (a) X - Direction

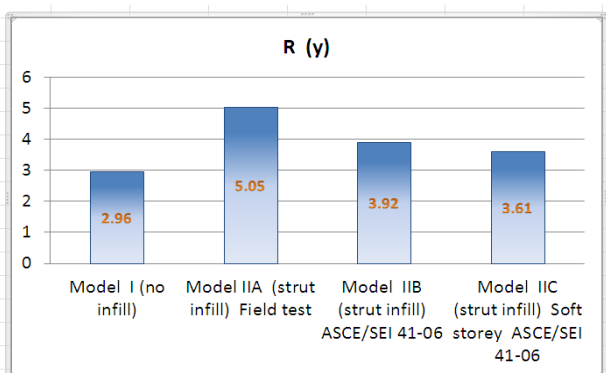

Fig. 18 (b) Y - Direction

Fig. 18 The response modification factor (R) for Model I, Model IIA, Model IIB and Model IIC

## V. SUMMARY AND CONCLUSIONS

A 5-storey RC old type building, studied in this paper, is representative of old building type constructed in Madinah City before 30 years ago. These buildings types are almost consisting of reinforced concrete skeleton i. e. columns, beams and solid slab. The nonlinear static analytical procedure (Pushover) was applied for the evaluation of existing 5-storey RC old type building. The static nonlinear analysis combined the application of the dead load followed by the application of the lateral seismic forces which were increased up to failure under displacement control. The effects of modeling the building without infill walls and with infill as equivalent truss model according to equation, suggested by Alguhane [22] to match field test measurements, and to ASCE/SEI 41 [7] on the performance point as well as capacity and demand spectra have been investigated. The results for the studied building show that:

- Seismic evaluation of this type of building indicates that modeling the building as skeleton frame elements does not satisfy the code requirements for response modification factor (2.5 according to Saudi Building Code SBC 301 [28]).
- Including infill wall in the analysis, according to updated model from field measurements and according to the ASCE/SEI 41, give increase the stiffness of the building

and give higher value of response modification factor and over-strength factor satisfying the code requirements. The structural performance level and hinge status at target displacement are also improved after accounting for masonry infill walls modeling.

- The presence of ground soft storey in the building reduces the stiffness of the building and gives lower value of R. This shows the important of the presence of infill walls in ground floor for improving the seismic evaluation of the building.

## REFERENCES

- [1] J. Roobol (2007) "Cenozoic faults in Western Saudi Arabia" In: 7th meeting of the Saudi society for geosciences, King Saudi University, Riyadh, Saudi Arabia.
- [2] M. Al-Saud (2008) "Seismic characteristics and kinematic models of Makkah and central Red Sea regions" Arab J. Geosci, 1:49-61.
- [3] S. Aldamegh, H. Moussa, S. Al-Arifi and M. Moustafa (2012) "Focal mechanism of Badr earthquake, Saudi Arabia of August 27, 2009" Arab J Geosci (2012) 5:599-606.
- [4] F. J. Crisafulli, A. J. Carr and R. Park (2000) "Analytical modeling of in-filled frame structures-A General Review" Bulletin of the New Zealand Society for Earthquake Engineering, 33(1), 30-47.
- [5] F. J. Crisafulli and A. J. Carr (2007) " Proposed macro-model for the analysis of in-filled frame structures " Bulletin of the New Zealand Society for Earthquake Engineering, Vol. 40, No. 2, June 2007.
- [6] Federal Emergency Management Agency, FEMA 356, (2000), "Pre-standard and Commentary for seismic re-habitation of buildings", Washington, D.C.
- [7] ASCE/SEI 41, (2007) "Seismic Rehabilitation of Existing Buildings, American Society of Civil Engineers, Reston, Virginia.
- [8] P. Asteris, D. Kakaletsis, C. Chrysostomou and E. Smyrou (2011) "Failure Modes of In-filled Frames" Electronic Journal of Structural Engineering 11(1).
- [9] I. Haris, Z. Hortobagyi, (2012), "Comparison of experimental and analytical results on masonry infilled RC frames for cyclic lateral load", Periodical Polytechnic Civil Engineering.
- [10] D. Samoila (2012) "Analytical modeling of masonry in-fills", Civil Engineering and Architecture, 55(2), 2012, 127-136.
- [11] SAP2000, Integrated Software for Structural Analysis & Design. Computers & Structures, Inc., Berkeley, California, USA, 2011.
- [12] ATC-40 (1996) "Seismic evaluation and retrofit of concrete building" Report, Applied Technology Council. Redwood City, California.
- [13] Federal Emergency Management Agency, FEMA 273, (1997), "Guidelines for the Seismic Rehabilitation of Buildings", Washington, D.C.
- [14] Federal Emergency Management Agency, FEMA 440, (2005), "Improvement of Nonlinear Static seismic analysis procedures", Washington, D.C.
- [15] ATC-19(1995) "Structural response modification factors" Report, Applied Technology Council. Redwood City, California.
- [16] C. M. Uang (1991) "Establishing R (or  $R_w$ ) and  $C_d$  factors for building seismic provisions" Journal of structural Engineering, ASCE, 19-28.
- [17] A. J. Kappos (1999) "Evaluation of behavior factors on the basis of ductility and over-strength studies" Engineering Structures, V. 21, No. 9, pp. 823-835.
- [18] A. M. Mwafy, A. S. Elnashai (2002) "Calibration of force reduction factors of RC buildings" Journal of Earthquake Engineering, 239- 273.
- [19] M. R. Maheri and R. Akbari (2003) "Seismic behavior factor, R, for steel X-braced and knee-braced RC buildings" Engineering Structures, Vol. 25(12), pp. 1505-1513.
- [20] E. Miranda and V. V. Bertero (1994) "Evaluation of Strength Reduction Factors for Earthquake-Resistant Design" Earthquake Spectra, 10(2), 357-379.
- [21] NBCC (2005). National Building Code of Canada 2005, National Research Council, Ottawa.
- [22] T. M. Alguhane, (2014) "Monitoring of buildings structures in Madinah", Ph.D., Ain Shams University Faculty of Engineering 2014.
- [23] Euro-code-6(2005) "Design of masonry structures, General Rules and Rules for Buildings Rules for Reinforced and Unreinforced Masonry" European Committee for standardization, Brussels ENV1996-1-1.

- [24] S. Akkar, A. Metin (2007) "Assessment of improved nonlinear static procedures in FEMA-440" *Journal of Structural Engineering*, ASCE;133(9):1237-46.
- [25] A. K. Chopra, and, C. Chintanapakdee (2004) "Evaluation of modal and FEMA pushover analyses: vertically regular and irregular generic frames" *Earthquake Spectra*; 20(1):255-71.
- [26] E. Irtem and U. Hasgul (2009) "Investigation of effects of nonlinear static analysis procedures to performance evaluation on low-rise RC buildings" *Journal of Performance for Constructed Facilities*, ASCE; 23(6):456-66.
- [27] E. Kalkan and S. K. Kunnath (2007) "Assessment of current nonlinear static procedures for seismic evaluation of buildings". *Engineering Structures*;29(3): 305-16.
- [28] Saudi Building Code - Structural requirements for Loads and Forces - SBC 301 (2007).