

# FEM and Experimental Modal Analysis of Computer Mount

Vishwajit M. Ghatge, David Looper

**Abstract**—Over the last few decades, oilfield service rolling equipment has significantly increased in weight, primarily because of emissions regulations, which require larger/heavier engines, larger cooling systems, and emissions after-treatment systems, in some cases, etc. Larger engines cause more vibration and shock loads, leading to failure of electronics and control systems.

If the vibrating frequency of the engine matches the system frequency, high resonance is observed on structural parts and mounts. One such existing automated control equipment system comprising wire rope mounts used for mounting computers was designed approximately 12 years ago. This includes the use of an industrial-grade computer to control the system operation. The original computer had a smaller, lighter enclosure. After a few years, a newer computer version was introduced, which was 10 lbm heavier. Some failures of internal computer parts have been documented for cases in which the old mounts were used. Because of the added weight, there is a possibility of having the two brackets impact each other under off-road conditions, which causes a high shock input to the computer parts. This added failure mode requires validating the existing mount design to suit the new heavy-weight computer.

This paper discusses the modal finite element method (FEM) analysis and experimental modal analysis conducted to study the effects of vibration on the wire rope mounts and the computer. The existing mount was modelled in ANSYS software, and resultant mode shapes and frequencies were obtained. The experimental modal analysis was conducted, and actual frequency responses were observed and recorded.

Results clearly revealed that at resonance frequency, the brackets were colliding and potentially causing damage to computer parts. To solve this issue, spring mounts of different stiffness were modeled in ANSYS software, and the resonant frequency was determined. Increasing the stiffness of the system increased the resonant frequency zone away from the frequency window at which the engine showed heavy vibrations or resonance. After multiple iterations in ANSYS software, the stiffness of the spring mount was finalized, which was again experimentally validated.

**Keywords**—Experimental Modal Analysis, FEM Modal Analysis, Frequency, Modal Analysis, Resonance, Vibration.

## I. INTRODUCTION

**O**IL and gas stimulation equipment consists of pump trailers, blenders, proppant handling systems, etc., which are designed to achieve maximum reliability with minimal maintenance, even in extremely harsh oilfield environments [1]. A typical fracturing pump trailer is shown in Fig. 1. To

help enhance oil productions and reduce pad layout, these equipment are built to be more powerful so that fewer pumping units are required for operation on location. To achieve more power, higher-capacity engines with Environmental Protection Agency (EPA) norms are installed.



Fig. 1 Typical fracturing pump trailer

The engine mounting system generally consists of the engine, transmission, supplementary systems, and several mounts connected to the vehicle structure. At higher speeds, these engines create noise and vibration. Modern engine mounting systems have been successfully applied to isolate the driver and passenger from the noise, vibration, and harshness (NVH) generated from power train system. However, there is still a need to improve the performance of engines and other mounting systems, for several reasons.

One reason is that the requirements of vibration and noise isolation for vehicles are increased for better operator comfort. Another is a result of emissions regulations, which require larger/heavier engines, larger cooling systems, and emissions after-treatment systems. The comfort requirements, the weight reduction, and the increased engine power sometimes have adverse effects on vibratory behavior. These aspects are often conflicting. Substantial improvement in the performance of mounting systems can help resolve such conflicting requirements. There are several studies on the dynamic performances of mounting system. The current industrial strategies use a modal approach to analyze and study the response to an excitation in terms of modal frequency and mode shapes. Modes are used as a simple and efficient means of characterizing resonant vibration. The majority of structures can be made to resonate. That is, under the proper conditions, a structure can be made to vibrate with excessive, sustained, oscillatory motion [2].

One such existing computer mount was designed approximately 12 years ago for an automated control equipment system. This included the use of an industrial grade computer to control the system hardware of fracturing equipment. The original computer was an Azonix brand which had a smaller lighter enclosure. After a few years, a Daisy Data Displays enclosure was added. The existing mount was

Vishwajit M. Ghatge is with Halliburton, Pune, Maharashtra, 411046 India (phone: +91-20-4015 8000; fax: +91-20-4015 8199; e-mail: Vishwajit.ghatge@halliburton.com).

David Looper is with Halliburton, Duncan, OK 73536 USA (e-mail: dave.looper@halliburton.com).

still suitable for this new computer, until the newest version was introduced, which is 10 lbm heavier. Some failures of internal parts have been reported when exposed to vibration in the field resulting from the two brackets colliding under off-road conditions, which causes a high shock input to the computer parts. The location of the Daisy Data Display computer is shown in Fig. 2.



Fig. 2 Location of Daisy Data Displays computer on trailer

## II. INVESTIGATION OF FAILURE

To identify the problem, the Daisy Data Displays computer was experimentally tested on a shaker table. The shaker table was pulsed with different values of acceleration (g's) for vertical input shock tests. Then vertical input sine sweep tests were also studied, as suggested by the International Electrotechnical Commission (IEC) [3]. Further study of the test outputs and failure analysis was performed to investigate the cause of failure.

### A. Experimental Analysis of Daisy Data Displays Computer

The Daisy Data Displays computer was experimentally tested by hard-mounting it to the test fixture, as per the manufacturer's suggestions and guidelines, to duplicate the manufacturer's testing. Fig. 3 shows the test setup, in which the Daisy Data Displays computer was hard-mounted to the test fixture and the fixture was hard-mounted on the shaker table.



Fig. 3 Test setup for Daisy Data Displays computer

Accelerometers were placed on different locations of the computers to measure the response. Dytran Model 3023A2

type accelerometers were used. As per IEC standards for vibration testing, both vertical input shock tests and sine sweep tests were conducted [3]. The control computer and Fast Fourier Transform (FFT) analyzer together acted as the data acquisition system. In the data acquisition system, the frequency response function was plotted with the obtained signals. The FFT output is shown in Figs. 4 and 5 for two sine sweep tests conducted with a 0.5 and 2g peak for a frequency window of 5 to 500 Hz input for two full cycles, respectively.

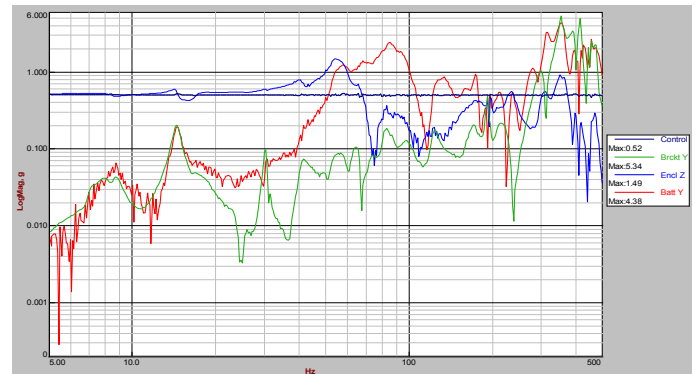

Fig. 4 Vertical input sine sweep test with 0.5g peak.

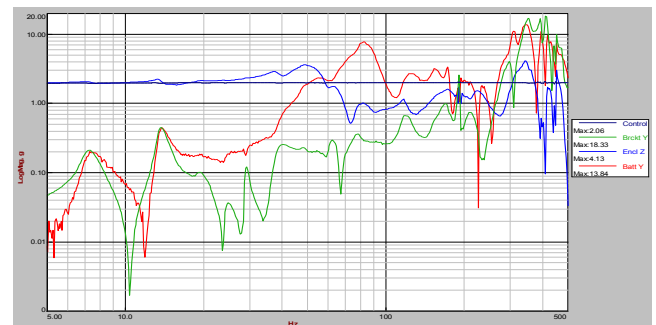

Fig. 5 Vertical input sine sweep test with 2g peak.

The test observations were as below.

- i. The vertical impacts in all of the three shock tests caused multiple responses of equal size in the mounting direction on the battery.
- ii. The two sine sweep tests showed that the battery does not have a response greater than the sine sweep input until the 60 to 110 Hz frequency band. This band is outside of the range of frequencies expected to be input to the Daisy Data Displays enclosure on the isolated brackets.
- iii. The computer booted up after every test and displayed the correct time and date in every instance.

### B. Experimental Analysis of Existing Daisy Data Displays Computer Mount

The existing brackets used to mount the Daisy Data Displays computer were tested using experimental modal analysis. The existing mount was excited for a frequency range, as defined by IEC standards. Fig. 6 shows the test setup, in which the Daisy Data Displays computer was hard-mounted to the suspended bracket, which was supported from the fixed bracket and test fixture by spring mounts. The fixed

bracket was hard-mounted to the test fixture. This mounting duplicated the mounting of the Daisy Data Displays computer on the pump trailers. Accelerometers were placed on different locations of the fixed bracket to measure the response. Dytran Model 3023A2 type accelerometers were used. As per IEC standards for vibration testing, vertical input sine sweep tests were planned with a 1g peak and 5 to 500 Hz input for two full cycles. The control computer and FFT analyzer together acted as the data acquisition system. In the data acquisition system, the frequency response function was plotted with the obtained signals.

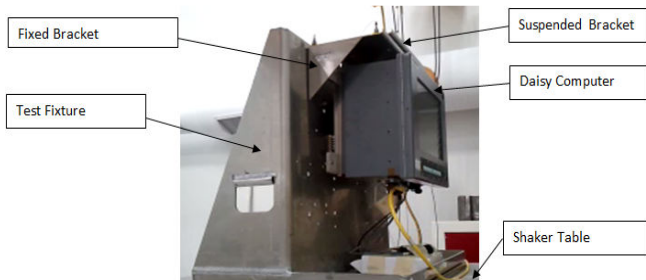

Fig. 6 Test setup for existing Daisy Data Displays computer mount

The FFT output of the tests is shown in Fig. 7.

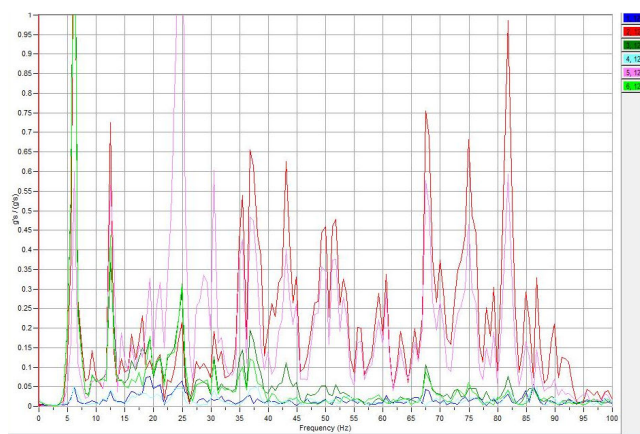

Fig. 7 Vertical input sine sweep test with 1g peak

The test observations were as follows:

- The sine sweep testing clearly showed impacting of the two brackets with each other.
- The hammering frequency was in the 36 to 37 Hz frequency band. This band is within the range of frequencies expected to be input to the Daisy Data Displays enclosure when mounted on pump trailers.

### C. Test Results Analysis

Test results analysis determined the following:

- The Daisy Data Displays computer test showed that the computer was meeting the manufacturer's guidelines for vibration testing.
- The existing mount analysis showed the impact of the two brackets at resonant frequency.

- This hammering of the two brackets might cause internal failure of computer parts.
- This analysis showed that the existing design was not suitable and design modifications were required for the Daisy Data Displays computer mount.

### III. FEM ANALYSIS

FEM is a numerical procedure for solving physical problems governed by a differential equation or an energy theorem. FEM provides an approximate solution. The domain of the physical problem is discretized into the finite elements. The elements are connected at points called nodes. The assemblage of elements is called a finite element mesh. The finite element mesh is represented by a system of algebraic equations to be solved for unknowns at nodes. The nodal unknowns are values of the physical problem. The nodal unknowns can be displacements in structural problems, temperatures in heat transfer problems, and velocity or pressure potentials in fluid flow problems. To use FEM models with confidence, it was found to be necessary to confirm the accuracy of the model by comparing the modal parameters (frequency, damping, and mode shapes) predicted by the model with the modal parameters identified by actually testing the structures [4].

#### A. FEM Modal Analysis of Existing Daisy Data Displays Computer Mounts

A general-purpose commercial finite element code, ANSYS software, was applied to conduct the dynamic modal analysis simulations. The Automated Sweep and Hex-dominant method was used for the geometry meshing in vibration simulations shown in Fig. 8. The Sweep method was used to mesh parts, which are automatically detected with Hex mesh. The two mounting brackets were separately meshed using the Hex-dominant method [5].

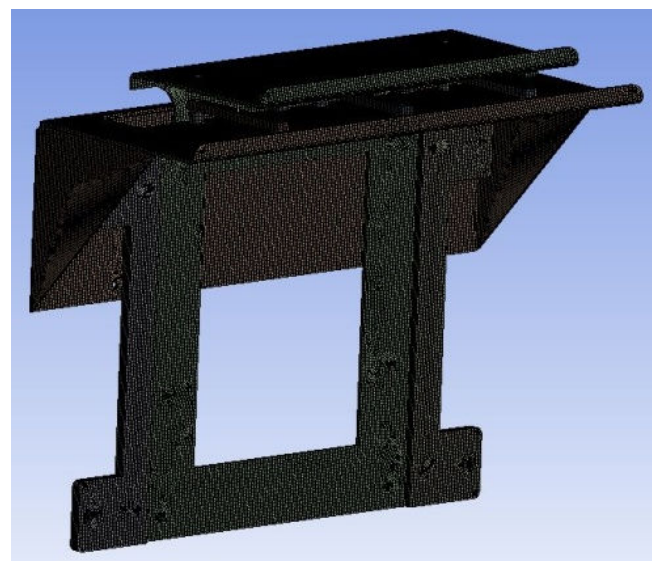

Fig. 8 Meshed computer mount

The following boundary conditions were applied to the meshed model. Physically, the four mounting locations on the fixed bracket are fixed by bolting on the trailer body. Hence, these four mounting locations are constrained by fixed support. Fig. 9 shows the applied boundary conditions for the fixed bracket.

Physically, the two mounting locations of the spring mounts are fixed by bolting on the trailer body or the brackets. Hence, these two mounting locations are constrained by fixed support Fig. 10 shows the applied boundary conditions for the spring mount fixed to the trailer.

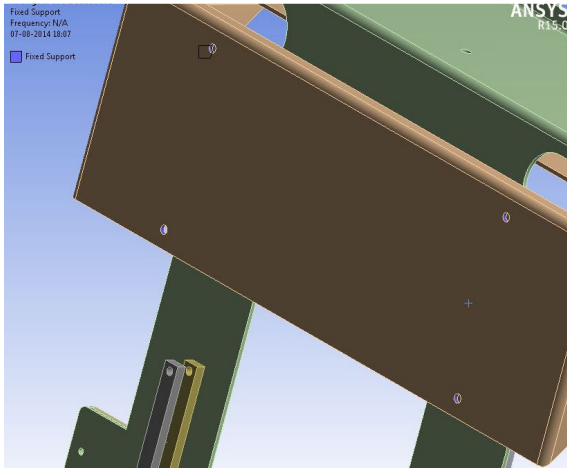

Fig. 9 Boundary Condition 1 for modal analysis

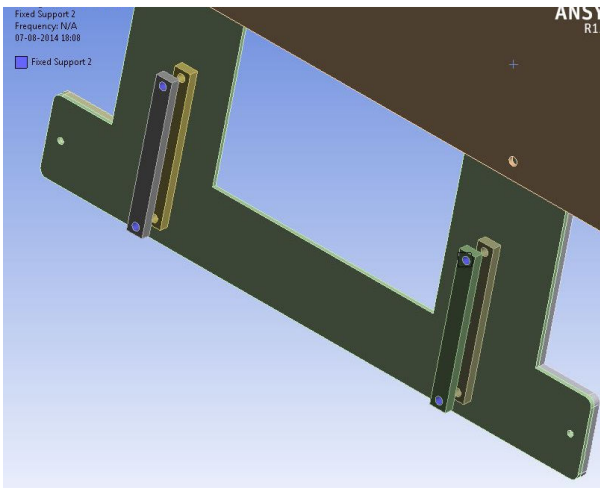

Fig. 10 Boundary Condition 2 for modal analysis

The mass of the Daisy Data Displays computer is added as a point mass of 50 lbm at the diagonal center of the mounting locations and at the center of the width of the computer. Fig. 11 shows the applied boundary conditions for the weight of the computer.

The material used for the computer mount is steel with the following mechanical properties:

- Density = 7850 kg/m<sup>3</sup>
- Young's modulus = 2E+11 Pa
- Poisson's ratio = 0.3

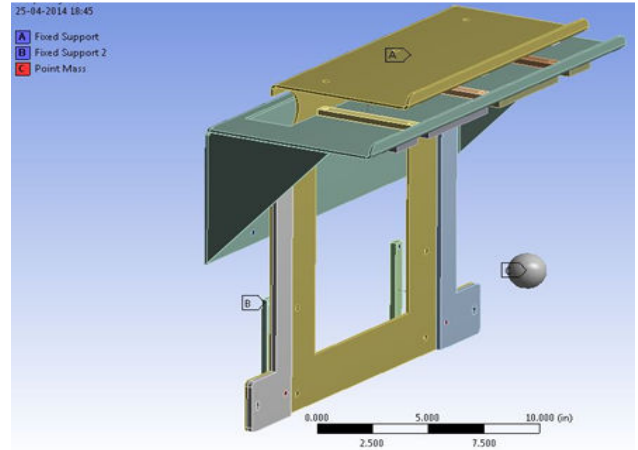

Fig. 11 Boundary Condition 3 for modal analysis

Contacts for the cable mounts were added in the FEM analysis model, as shown in Fig. 12.

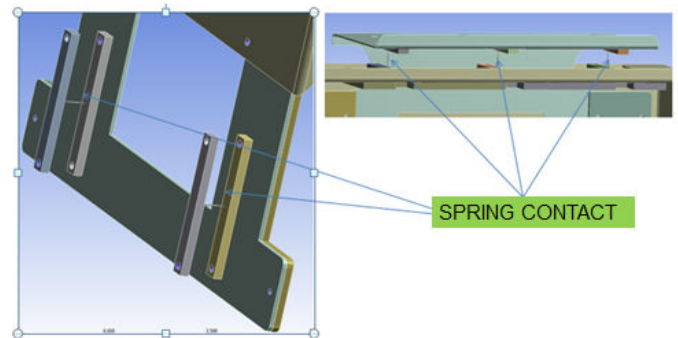

Fig. 12 Contacts for cable mounts

The analysis setting for modal was performed in ANSYS. The frequency window was defined from 1 to 500 Hz, and the first 10 mode shapes were studied. The damping parameter was not considered in the analysis, as the modal frequencies and the resulting mode shapes are the focus of the study. The first 10 modal frequencies obtained from the simulation are given in Table I.

TABLE I  
 RESULTS OF FEM MODAL ANALYSIS OF EXISTING COMPUTER MOUNT

Sr. No.	Mode	Frequency (Hz.)
1	1	5.3137
2	2	6.8563
3	3	7.9725
4	4	8.9997
5	5	30.507
6	6	34.622
7	7	58.437
8	8	64.128
9	9	105.82
10	10	108.68

From the simulation results, the hammering of the two brackets at the sixth mode with a modal frequency of 34.622 Hz can be observed. The observed mode shape is shown in Fig. 13.

The frequency obtained from FEM analysis was 34.622 Hz, and the experimental result for modal analysis resulted in a hammering frequency of approximately 37 Hz. The percentage variation between experimental and FEM results was 6.43%. These results showed that a close correlation was established in both analyses. Closely duplicating the experimental conditions into the FEM model was therefore successful. Using this correlation, and all other analysis settings boundary conditions, it was decided to modify the computer mount and run various FEM analyses for a feasibility study.

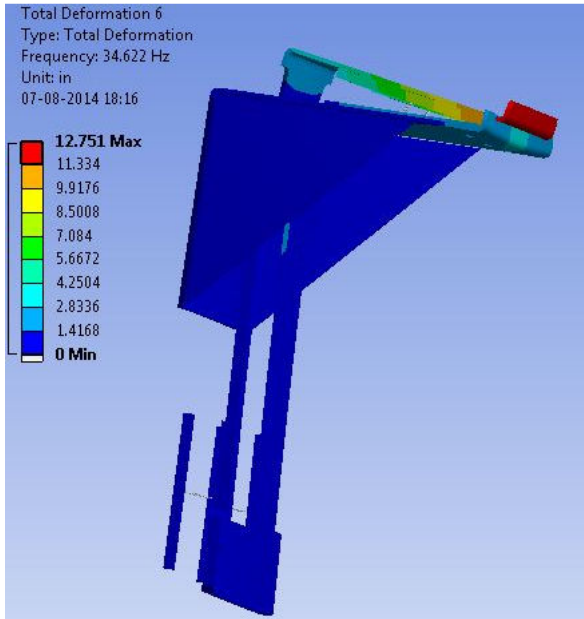

Fig. 13 Sixth mode shape of existing computer mount

### B. Design Modifications of Daisy Data Displays Computer Mount

The computer mount design was modified by adding mass to the brackets, and various springs of higher stiffness were studied for dynamic characteristics. A combination of mass addition and higher stiffness was also studied. Analysis was performed in ANSYS software for all of the modified designs to obtain the modal frequencies and mode shapes. Boundary conditions were kept identical to those used for previous tests. The results are shown in Table II.

TABLE II  
RESULTS OF FEM MODAL ANALYSIS

Sr. No.	FEM Model	Mount Stiffness (lbf/in.)	Hammering Mode Frequency (Hz)
1	Original bracket	135	34.622
2	Original bracket with mass addition	135	29.839
3	Original bracket with inline mass addition	135	31.756
4	Modified bracket with five mounts	135	34.979
5	Original bracket	696	39.267
6	Modified bracket with five mounts	696	37.783
7	Original bracket with mass addition	696	35.903

### C. Feasibility Study

The following parameters should be considered before selecting the modified design options for the computer mount:

- More than 500 of the existing brackets have been manufactured.
- More than 1,000 of the existing brackets must be retrofitted in the field.
- To keep the mounting dimensions the same, only Tech Products 10125 series cable mounts should be considered.
- The hammering frequency of the proposed solution should not fall in the frequency window of the engine, which is 30 to 37.5 Hz.

After studying the FEM results in Table II the only feasible solution that would fit all design constraints discussed previously was to change the stiffness of the cable mounts to 696 lbf/in. which resulted in a hammering frequency of 39.267 Hz. This solution was very easy for retrofit, as it did not require any additional machining to the brackets. The FEM solution required experimental validation before implementation in the field.

### IV. EXPERIMENTAL MODAL ANALYSIS OF PROPOSED MOUNT DESIGN

The proposed mount design was experimentally tested using the same boundary conditions and test parameters with which the existing brackets were tested. Fig. 14 shows the test setup.

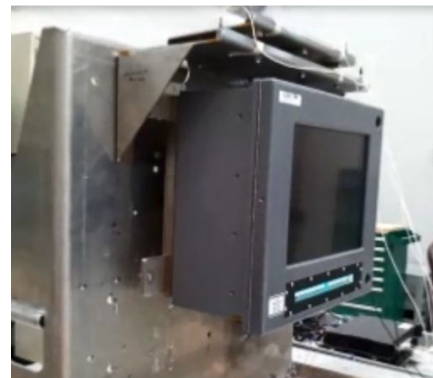

Fig. 14 Experimental setup for modal testing

Accelerometers were placed on different locations of the bracket to measure the response. Dytran Model 3023A2 type accelerometers were used. Four single-axis accelerometers were placed at the outside edge of both the fixed and suspended brackets. In FFT output of the tests, shown in Figs. 15 and 16, the Bracket L, Bracket R, Iso Brkt. L and Iso Brkt R correspond to accelerometer locations on Left and right side of the fixed brackets and suspended brackets respectively. As per IEC standards for vibration testing, vertical input sine sweep tests were planned with a 1g peak and 5 to 500 Hz input for two full cycles. In the data acquisition system, the frequency response function was plotted with the obtained signals.

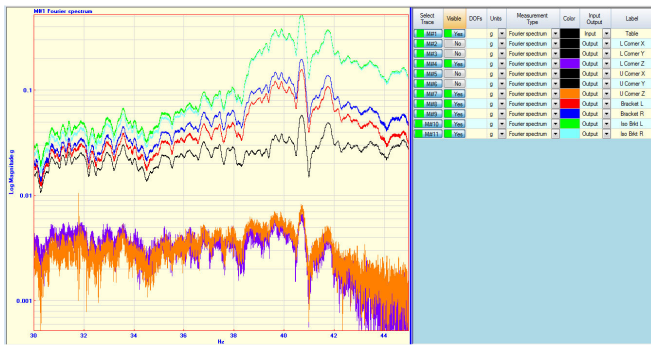

Fig. 15 Zoomed in results from 30 to 45 Hz

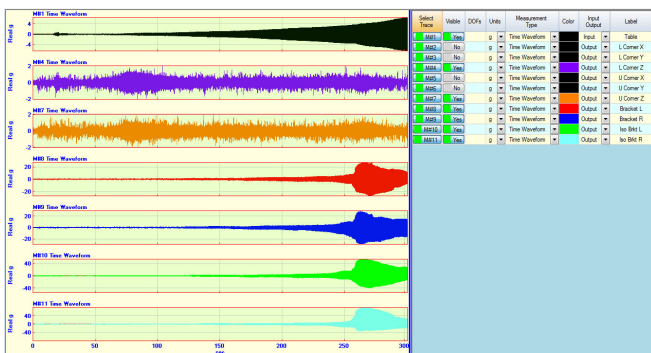

Fig. 16 Real g's recorded over the 5 to 45 Hz sweep up

## V. RESULTS AND DISCUSSIONS

The frequency obtained from FEM analysis was 39.267 Hz, and experimental output from FFT analyzer for modal analysis resulted in a hammering frequency approximately 41 Hz. The percentage variation between the experimental and FEM results was 4.41%. These results showed that a close correlation was established between both analyses. Therefore, closely duplicating the experimental conditions into the FEM model was successful. The modified design reduced the colliding of the two brackets, which in turn helped reduce the internal failure of computer parts.

## VI. CONCLUSION

The following conclusions can be reached from the present study.

- The existing design of the computer mount showed colliding of two brackets, causing internal failure of computer parts. After suggested modifications, the modified mount was shown to be effective in both numerical and experimental testing.
- Modal analysis of proposed mount was performed, and it determined that the fundamental natural frequency of the two brackets colliding was approximately 41 Hz, which is greater than the excitation frequency. Also, the fundamental natural frequency obtained from numerical analysis was validated using experimental modal analysis.
- FEM modal analysis was performed with variations in mass and spring stiffness to find the corresponding modal frequencies. After identifying the most suitable spring mount, the new design was experimentally validated.

Using this technique, it was observed that the computer aided engineering (CAE) approach was more economic and time saving than the classical design-test approach.

## ACKNOWLEDGMENT

The authors thank the management of Halliburton for support and permission to publish this paper. They also express gratitude to all of the team members who contributed to the job design, preparation, and execution of the operation to achieve the results presented in this paper.

## REFERENCES

- Halliburton, "HT-2000 Pump Trailer (FPR-K)," 2012. [http://www.halliburton.com/public/pe/contents/Data\\_Sheets/web/H/H09148%20HT-2000%20Pump%20Trailer%20SDS.pdf](http://www.halliburton.com/public/pe/contents/Data_Sheets/web/H/H09148%20HT-2000%20Pump%20Trailer%20SDS.pdf), accessed December 2014.
- C.Y. Song, "Design Optimization and Development of Vibration Analysis Program for Engine Mount System." Vol. 84, March 2006
- International Electrotechnical Commission, "Environmental Testing Vibration (Sinusoidal) – IEC 68-2-6," 1988.
- Kenneth A. Ramsey, "Experimental Modal Analysis, Structural Modifications and FEM Analysis on a Desktop Computer." Structural Measurement Systems, San Jose, California. Sound and Vibration, February 1983
- ANSYS, "http://www.ansys.com/Products/Workflow+Technology/ANSYS+Workbench+Platform/ANSYS+Meshing/Features/Meshing+Metho ds:+Hexahedral," accessed December 2014.